



Non-penetrative and modular access products

The Big Foot Safe Access range is designed to allow a secure route for service engineers and other trades to gain access to plant and for managing the flow of other personnel. The metalwork is galvanised to ensure maximum corrosion resistance. Both systems are supplied from stock and are quick and easy to install on site.

## Step Over

- Flat packed for ease of handling
- 3 different step options
- 1m landing
- Adjustable leg height
- Standard sizes stocked

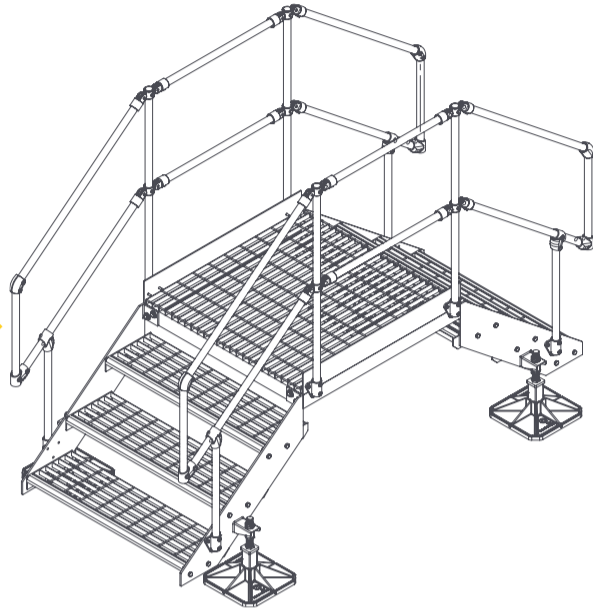

### KIT INCLUDES

305mm leg assembly & rubber mats	x 4	Landing grating	x 1
Step handrail	x 4	Landing kickplates	x 2
Step stringers	x 4	Landing handrails	x 2
Step grating	x 2/3/4	Fixings and assembly instructions	x 1

Big Foot Step Overs available with 2, 3 and 4 steps and a 1m landing section. The four legs on each Step Over are supplied with 305mm feet and rubber mats for stability. For safe passage over small hazards our Big Foot Step Over Platform is available.

Big Foot Rapid Walkway is ideal for establishing clear, safe non-penetrative pathways around installations on a flat roof. The gritted GRP top to the walkway grating provides a permanent non-slip surface in any weather and is supported on Fix-it Foot feet.

### PRODUCT INFORMATION

Model	2 Step unit	3 Step unit	4 Step unit
Part no.	<b>B6939</b>	<b>B6940</b>	<b>B6941</b>
Foot size (mm)	305	305	305
Clearance height (mm)	560	780	1000
Width (mm)	1492	1492	1492
Length (mm)	1713	2213	2713

## Step Over Platform

### PRODUCT INFORMATION

Model	600	1000	Handrail
Part no.	<b>B9200</b>	<b>B9201</b>	<b>B6942</b>
Foot size (mm)	200	200	-
Clearance height (mm)	155	155	-
Width (mm)	600	1000	-
Length (mm)	1000	1000	1000

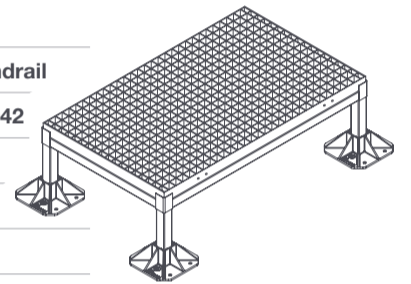

## Rapid Walkway

- Fast install
- Various length rails available from stock
- Non-penetrative recycled Fix-it Foot
- Non-slip grip walkway
- Flat packed for ease of handling

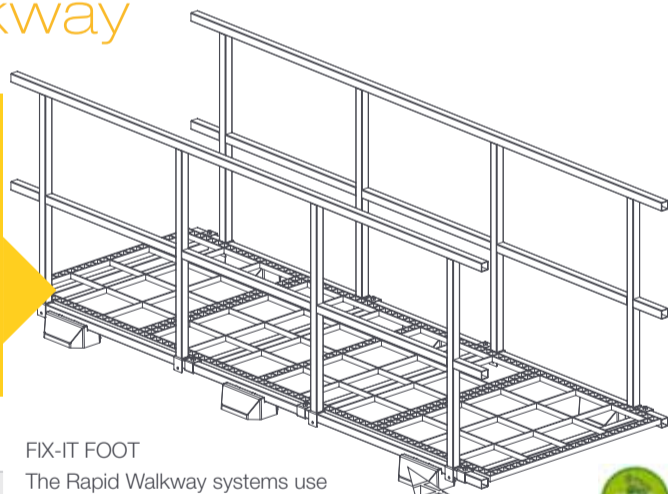

### KIT INCLUDES

Fix-it Foot 250 feet
Cross bars
Grating
End bars
Assembly instructions

### FIX-IT FOOT

The Rapid Walkway systems use the UV stable Fix-it Foot as a neat and tidy support solution, made from durable recycled rubber

PLEASE NOTE: Quantities and sizes within the kit vary depending on the size of walkway required



For ease of specification these products are detailed on the following building product libraries:



### PRODUCT INFORMATION

Model	1m	2m	3m
Part no.	<b>B9105</b>	<b>B9106</b>	<b>B9107</b>
Overall length (mm)	1000	2000	3000
Overall width (mm)	1230	1230	1230
Height (mm)	120	120	120
Weight (kg)	32	58	85

### ACCESSORY INFORMATION

Model	90° Corner	1m Handrail (each)	2m Handrail (each)	3m Handrail (each)	T Junction
Part no.	<b>B9104</b>	<b>B9111</b>	<b>B9112</b>	<b>B9113</b>	<b>B9142</b>
Overall length (mm)	1120	1000	2000	3000	1000
Overall width (mm)	1120	-	-	-	1110
Height (mm)	120	1120	1120	1120	120
Weight (kg)	42	9	12	15	65

