

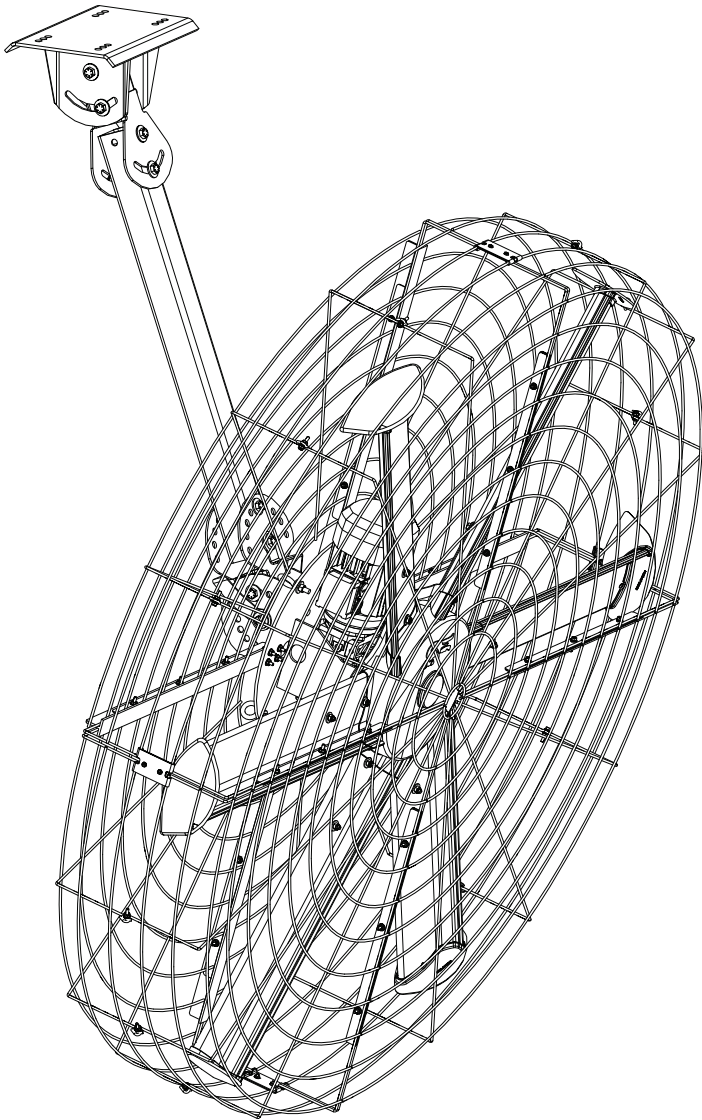

# INSTALLATION GUIDE

---

Pivot



# Installation Checklist

**Did a structural engineer approve the mounting structure?** See p. 6 for Big Ass Fans approved mounting structures.

**Are you familiar with the function and use of the safety cable?** See p. 15 for information on properly securing the safety cable.

**Will the fan be installed so that the airfoils are at least 10 ft (3.05 m) above the floor?**

**Will the fan be installed so that the airfoils have at least 2 ft (0.61 m) of clearance from obstructions?**

**Will the fan be installed so that it is not subjected to high winds, such as from an HVAC system?** Install the fan so that it is  $\geq 1x$  fan diameter away from a diffuser if the fan is at same level or above diffuser. If the fan is below a diffuser, install the fan so that it is  $\geq 2x$  fan diameter from the diffuser.

**Will the distance between multiple fans be at least 2.5x the fans' diameter when measured from the centers of the fans?**

**If installing the fan on an I-beam, is the upper yoke the correct size?** See p. 8 for more information on installing the fan to an I-beam.

**If you ordered multiple fans, did you keep the parts for each fan together?**

**Do you have the correct power circuit for the fan controller?** See p. 25 for information on selecting the correct circuit/fuse for the fan controller.

**Customer Service: 1-877-BIG-FANS**  
(International: +1 859 233 1271)

# Pivot Installation Guide

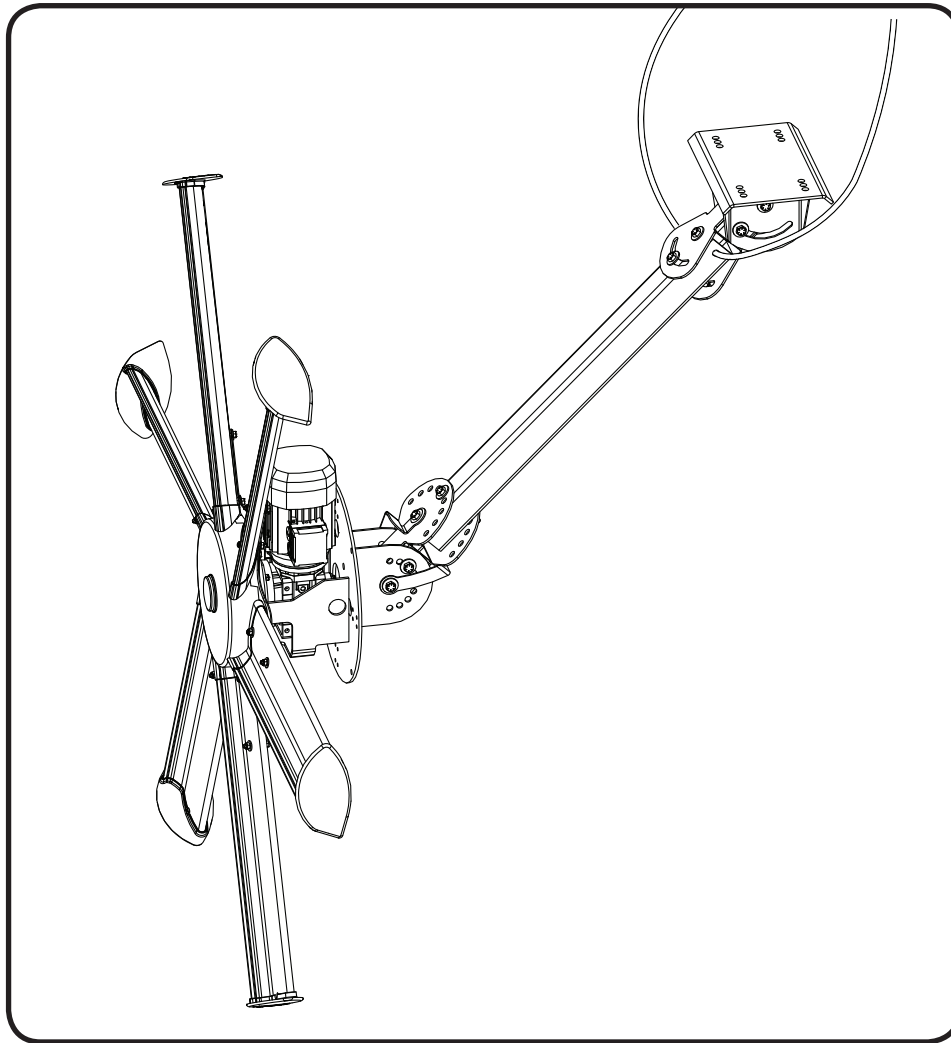

Installation Guide:  
Apr. 2015  
Rev. M



This product was manufactured in a plant whose Management System is certified as being in conformity with ISO 9001:2008.



**Intertek**

Conforms to ANSI/UL STD 507: Electric Fans  
Certified to CAN/CSA C22.2 No.113: Fans & Ventilators

## Contact Information

**Manufacturing**  
2425 Merchant Street  
Lexington, KY 40511  
1-877-BIG-FANS  
[www.bigassfans.com](http://www.bigassfans.com)

**Customer Service**  
2348 Innovation Drive  
Lexington, KY 40511  
1-877-BIG-FANS  
Intl.: +1 859 233 1271  
[www.bigassfans.com](http://www.bigassfans.com)

**Warranty Returns**  
800 Winchester Road  
Lexington, KY 40505  
1-877-BIG-FANS  
[www.bigassfans.com](http://www.bigassfans.com)

**Australia Office**  
Unit 22, 1029 Manly Road  
Tingalpa QLD 4173, Australia  
(07) 3292 0100  
[www.bigassfans.com/au](http://www.bigassfans.com/au)

Pivot and the Pivot logo are trademarks of Delta T Corporation, registered in the United States and/or other countries. All other trademarks used herein are the properties of their respective owners. No part of this document may be reproduced or translated into a different language without the prior written consent of Big Ass Fan Company. The information contained in this document is subject to change without notice. For the most up-to-date information, see the online Pivot Installation Guide at [www.bigassfans.com](http://www.bigassfans.com).

[www.bigasssolutions.com/patents](http://www.bigasssolutions.com/patents)



## IMPORTANT SAFETY INSTRUCTIONS READ AND SAVE THESE INSTRUCTIONS

**WARNING—TO REDUCE THE RISK OF FIRE, ELECTRIC SHOCK, OR INJURY TO PERSONS, OBSERVE THE FOLLOWING:**

- a) Installation work and electrical wiring must be done by qualified person(s) in accordance with all applicable codes and standards.
- b) When cutting or drilling into a wall or ceiling, do not damage electrical wiring and other hidden utilities.

**CAUTION:** The installation of a Big Ass Fan must be in accordance with the requirements specified in this installation manual and with any additional requirements set forth by the national electric code (NEC), ANSI/NFPA 70-2011, and all local codes. Code compliance is ultimately YOUR responsibility! Failure to comply with these codes could result in personal injury or property damage.

**WARNING:** The fan controllers contain high voltage capacitors which take time to discharge after removal of mains supply. Before working on the fan controller, ensure isolation of mains supply from line inputs at the fan controller's disconnect (L1, L2/N, L3). Wait three (3) minutes for capacitors to discharge to safe voltage levels. Failure to do so may result in personal injury or death. **NOTE:** Darkened display LEDs are not an indication of safe voltage levels.

**CAUTION:** Exercise caution and common sense when powering the fan. Do not connect the fan to a damaged or hazardous power source. Do not attempt to resolve electrical malfunctions or failures on your own. Contact Big Ass Fans if you have any questions regarding the electrical installation of this fan.

Suitable for use with solid-state speed controls.

**WARNING—To reduce the risk of fire, electric shock, and injury to persons, Big Ass Fans must be installed with Big Ass Fan-supplied controllers that are marked (on their cartons) to indicate the suitability with this model. Other parts cannot be substituted.**

**CAUTION:** When service or replacement of a component in the fan requires the removal or disconnection of a safety device, the safety device is to be reinstalled or remounted as previously installed.

**WARNING:** Risk of fire, electric shock, or injury to persons during cleaning and user-maintenance! Disconnect the appliance from the power supply before servicing.

**WARNING—TO REDUCE THE RISK OF FIRE, ELECTRIC SHOCK, OR INJURY TO PERSONS, OBSERVE THE FOLLOWING:**

- a) Use this unit only in the manner intended by the manufacturer. If you have questions, contact the manufacturer.
- b) Before servicing or cleaning unit, switch off power at service panel and lock the service disconnecting means to prevent power from being switched on accidentally. When the service disconnecting means cannot be locked, securely fasten a prominent warning device, such as a tag, to the service panel.

**CAUTION:** Do not bend the blades when installing, adjusting, or cleaning the fan. Do not insert foreign objects in between rotating fan blades.

**WARNING:** Stay alert and use common sense when installing fans. Do not install fans if tired or under the influence of drugs, alcohol, or medication. A moment of inattention while installing the fan may result in serious personal injury.

**CAUTION:** The installation of this fan requires the use of some power tools. Follow the safety procedures found in the owner's manual for each of these tools and do not use them for purposes other than those intended by the manufacturer.

**CAUTION:** The Big Ass Fans product warranty will not cover equipment damage or failure that is caused by improper installation.

**ATTENTION:** If installing the fan in the United States, the fan must be installed per the following National Fire Protection Association (NFPA) guidelines:

- The fan must be centered approximately between four adjacent sprinklers.
- The vertical distance from the fan to the sprinkler deflector must be at least 3 ft (91.4 cm).
- The fan must be interlocked to shut down immediately upon receiving a waterflow signal from the alarm system.

# Mounting Reference Guide

The following is intended as a reference guide for Pivot fan mounting methods. See the referenced pages for complete fan installation and operating instructions. Consult a structural engineer to determine which mounting method best suits your building structure.

I-Beam

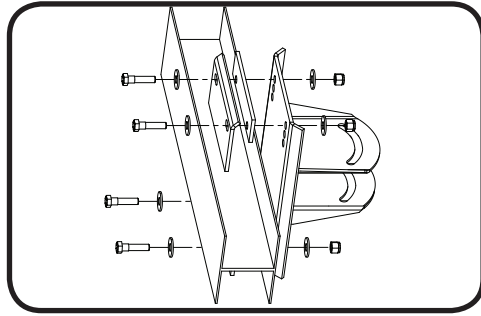
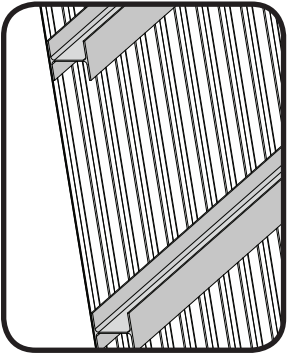

See page 8 for mounting instructions.

Bar Joists

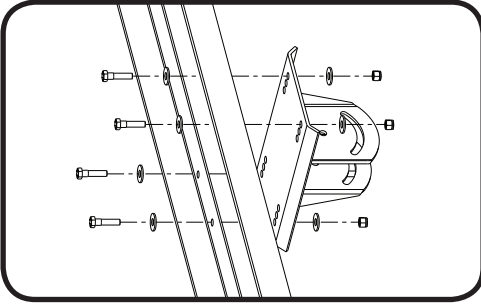
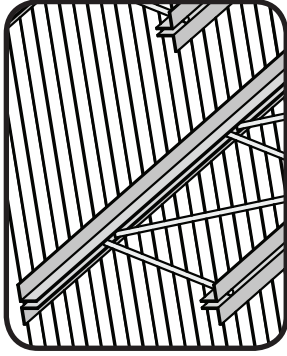

See page 9 for mounting instructions.

Z-Purlins

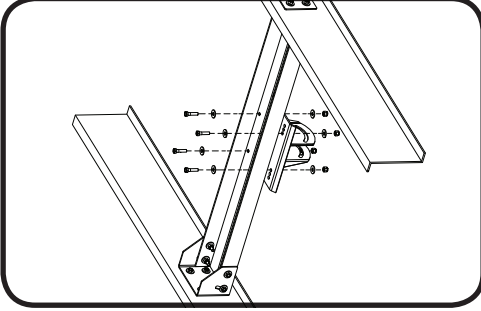
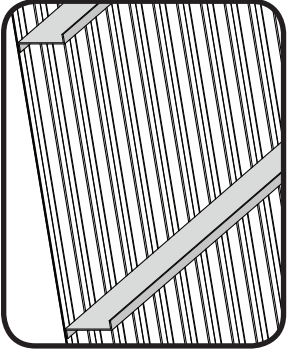

See complete instructions included with the Z-Purlin Installation Kit.

Solid Beam

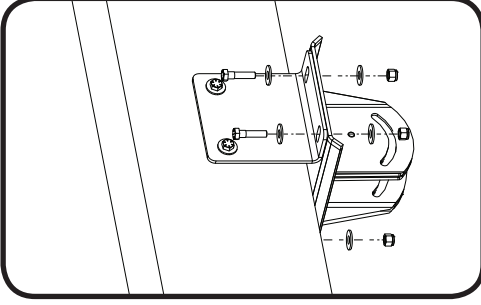
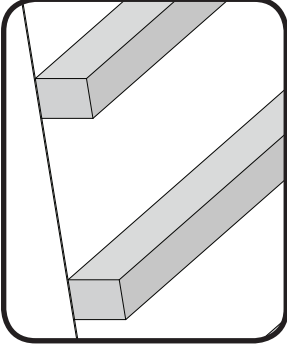

See complete instructions included with the L-Bracket Installation Kit.

I-Beam (Angled)

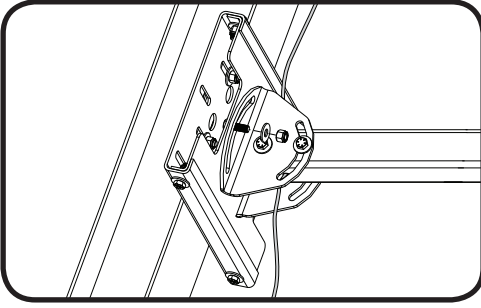
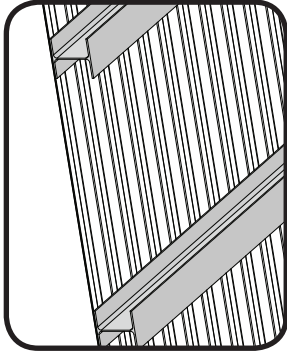

See complete instructions included with the Compound Angle Mount Installation Kit.



# Contents

<b>Introduction</b>	Safety Instructions.....	ii
	Mounting Reference Guide.....	iii
	Thank You.....	1
	About Big Ass Fans.....	1
	About this Fan.....	1
<b>Pre-Installation</b>	What's in the Box.....	2
	Parts Included.....	3
	Tools Needed.....	4
	Important Weights.....	4
	Fan Diagram.....	5
	Preparing the Work Site.....	6
	Pivot Angle.....	7
<b>Mounting Structure: I-Beam</b>	1. Attach Upper Yoke (to I-Beam).....	8
<b>Mounting Structure: Bar Joists</b>	1. Select Proper Angle Irons.....	9
	2. Pre-drill Angle Irons.....	10
	3. Fasten Angle Irons Together (if Span is Longer Than 8 ft).....	10
	4a. Fasten Single Angle Irons to Roof Structure Mounting Points.....	11
	4b. Fasten Double Angle Irons to Roof Structure Mounting Points.....	12
5. Attach Upper Yoke (to Angle Irons).....	13	
<b>Hanging The Fan</b>	1. Attach Balance Joint (to Upper Yoke).....	14
	2a. Attach Extension Tube (to Balance Joint).....	14
	2b. Attach Extension Tube (to Upper Yoke).....	14
	3. Secure Upper Safety Cable.....	15
	4. Attach Main Fan Unit (to Lower Yoke).....	15
	5. Attach Pivot Joint.....	16
	6a. Attach Lower Yoke (to Pivot Joint).....	16
6b. Attach Lower Yoke (to Extension Tube).....	17	
7. Attach Center Cap.....	17	
<b>Installing Airfoils</b>	1. Attach Winglets.....	18
	2. Position Airfoils and Trim.....	18
	3. Attach Airfoil Retainers.....	18
<b>Installing Cage</b>	1. Attach Cage Bracket.....	19
	2. Attach Upper Cage.....	19
	3. Attach Lower Cage Sections (to Upper Cage).....	20
	4. Secure Lower Cage.....	20
<b>Pivoting the Fan</b>	1. Adjust Pivot Joint and Lower Yoke.....	21
	2. Tighten Bolts on Upper Yoke and Balance Joint.....	21
<b>Installing Guy Wires</b>	1. Attach Eyebolt to Motor Frame.....	22
	2. Attach Beam Clamp.....	22
	3. Route Guy Wire through Grippler®.....	22
	4. Install Remaining Guy Wires.....	23
<b>Electrical Installation</b>	Electrical Installation Safety.....	24
	Electrical Installation Overview.....	24
	Controller Storage.....	24
	Power Requirements for Fan Controllers.....	25
	Mounting the Wall Controller.....	25
	Input Power Conditioning.....	26
	Conduit and Piping Guidelines.....	26
Power Wiring Guidelines.....	26	

<b>Electrical Installation (cont.)</b>	Grounding.....	27
	Installing the Electronic Programming Module (EPM).....	28
	Wiring: Early Suppression Fast Response (ESFR).....	29
	Wiring: 100–125V/200–250V Single-Phase Fan Controllers.....	30
	Wiring: 200–250V Three-Phase Fan Controllers.....	31
	Wiring: 400–480V & 575–600V Three-Phase Fan Controllers.....	32
	Daisy Chaining.....	33
	Wiring the Fan Motor: 9 Lead, Dual Voltage, Wye Motor Configurations.....	34
	Operating the Fan Controller.....	35
<b>Preventive Maintenance</b>	Annual Preventive Maintenance.....	36
	General Preventive Maintenance.....	36
	Annual Maintenance Checklist.....	37
<b>Troubleshooting</b>	Troubleshooting.....	39
<b>Warranty Return Instructions</b>	Acknowledgment & Return Instructions.....	40
	Warranty Claim Form Instructions.....	41
	Warranty Claim Form.....	43
	Responsibility Agreement.....	44
<b>Big Ass Fan Certified Installers</b>	Check-In Procedure.....	45
	Close-Out Procedure.....	47

# Introduction

1

Thank you and congratulations on your purchase of a Big Ass Fan, an efficient and cost-effective way to stay cool in the summer and warm in the winter. The revolutionary design of our fans combines the best of both form and function to bring power performance and a sleek look to any setting. More importantly, you have purchased a product that is backed by extensive research, thorough testing, and quality manufacturing. We're ready to answer any questions or comments at 1-877-BIG-FANS or visit our Web site at [www.bigassfans.com](http://www.bigassfans.com).

## Who we are and what we do

Big Ass Fans has been the preeminent manufacturer of large-diameter, low-speed fans since 1999. With a worldwide presence and located in beautiful Lexington, KY, we research, design, and manufacture the most effective air movement solutions on the market. Our never-ending commitment to quality and innovation keeps us at the leading edge of a burgeoning industry. With an eye to helping customers satisfy their needs, and a strong sense of corporate responsibility to the community, Big Ass Fans has redefined the way business is done.

## About this fan

### Specifications

Fan diameter	Motor size	RPM @ 60 Hz	Airfoil length	Fan weight*	Cage diameter	Voltage and Phase	Minimum circuit size	Maximum full load current
6 ft (1.8 m)	1.0 hp	180 RPM	28" (71 cm)	207 lb (90 kg)	74.5" (189.2 cm)	100–125 V, 1 $\Phi$	20 A	11.0 A
						200–250 V, 1 $\Phi$	15 A	5.5 A
						200–250 V, 3 $\Phi$	10 A	3.2 A
						400–480 V, 3 $\Phi$	10 A	1.6 A
						575–600 V, 3 $\Phi$	10 A	1.3 A

\* With 3-ft (0.9 m) extension tube.

# 2 Pre-Installation

## What's in the box

The fan and controller are shipped in one large box. The fan cage is shipped in a separate smaller box.

**⚠ CAUTION:** If you ordered multiple fans, be sure to keep the components of each fan together.

*Note: Dashed lines indicate internal boxes. Drawings are not to scale.*

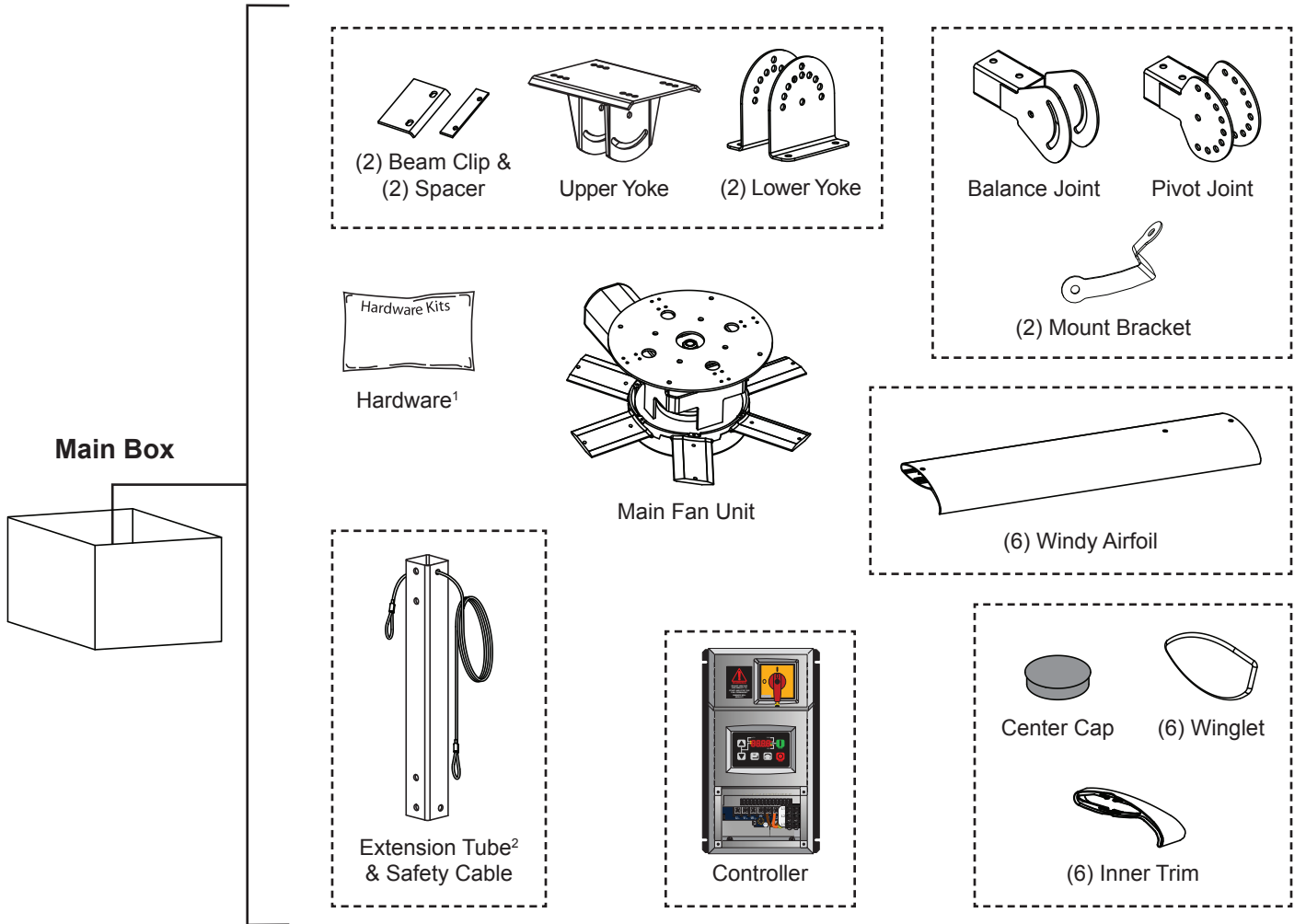



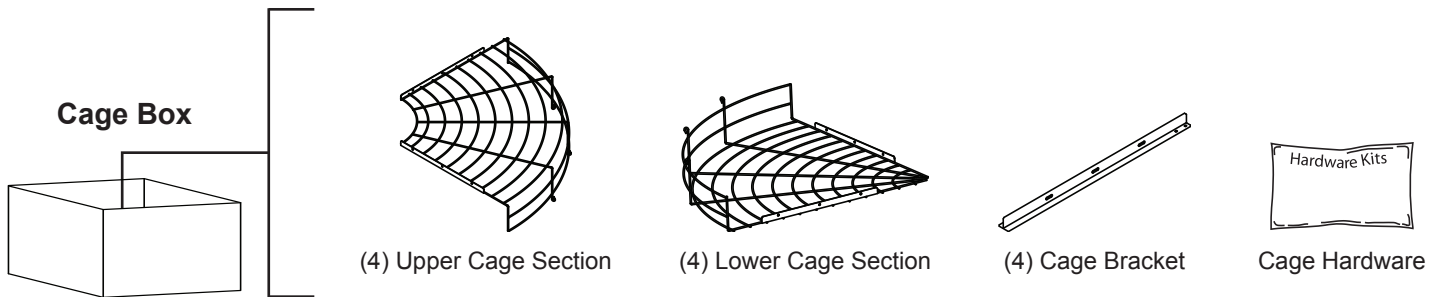



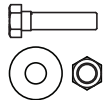
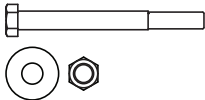
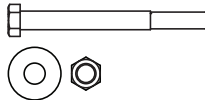
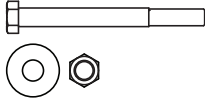
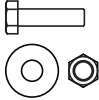

1. Kits for mounting and winglet hardware are packaged in the boxes of their respective parts. Guy wires and hardware (if ordered) are bagged separately.
2. If extension tube is over 3 ft, it will be shipped in a separate box.

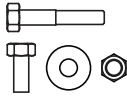
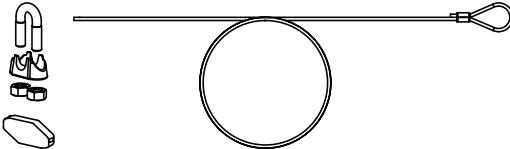
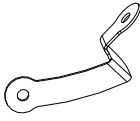
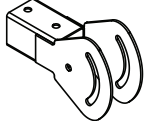
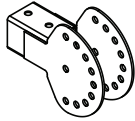
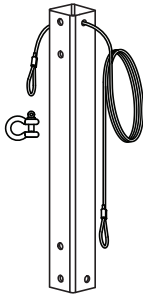
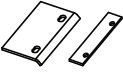

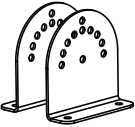
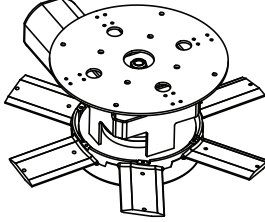
**Parts included**

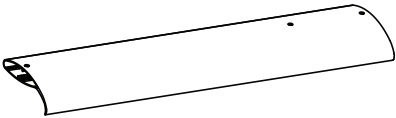
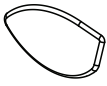
Note: Drawings are not to scale.

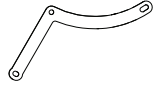
<b>Hardware</b>					
	<b>Beam Clip Hardware</b> (4) 1/2-13 x 2" GR 8 Bolt (8) 1/2" Flat Washer (4) 1/2-13 Nylock Nut	<b>Balance/Pivot Hardware</b> (4) 1/2-13 x 5" GR 8 Bolt (8) 1/2" Flat Washer (4) 1/2-13 Nylock Nut	<b>Extension Tube Hardware</b> (2) 1/2-13 x 4-1/2" GR 8 Bolt (4) 1/2" Flat Washer (2) 1/2-13 Nylock Nut		
					
	<b>Lower Yoke Hardware</b> (2) 1/2-13 x 4-1/2" GR 8 Bolt (4) 1/2" Flat Washer (2) 1/2-13 Nylock Nut	<b>Main Fan Unit Hardware</b> (4) 1/2-13 x 1 3/4" GR 8 Bolt (8) 1/2" Flat Washer (4) 1/2-13 Nylock Nut	<b>Winglet Hardware</b> (6) 10-24 x 1/2" Bolt (6) 10-24 x 3/4" Barrel		
					
<b>Airfoil Hardware</b> (12) 5/16"-18 x 2 1/4" GR 8 Bolt (36) 5/16" Flat Washer (12) 5/16"-18 Nut	<b>(4) Guy Wire Hardware<sup>1</sup></b> (1) 3/8-16 x 1" Eyebolt (2) 3/8" Washer (1) 3/8-16 Nylock Nut (1) 1/4" Beam Clamp (1) 1/4-20 x 1" Eyebolt		(1) 1/4-20 Hex Nut (2) Locking Carabiner (1) Guy Wire (1) Gripple® (2) Wire Rope Clip		
<b>Mounting</b>					
	(2) Mount Brackets	Balance Joint	Pivot Joint		
					
	(2) Beam Clip & Spacer				
	Center Cap	Upper Yoke	(2) Lower Yoke	Main Fan Unit	Extension Tube, Safety Cable <sup>2</sup> , & Shackle*
<b>Airfoils</b>					
	(6) Windy Airfoil	(6) Winglet	(6) Inner Trim	(6) Airfoil Retainer <sup>3</sup>	

1. Guy wires are designed to constrain fan's lateral movement and are only included in some fan packages. Big Ass Fans recommends using guy wires if the fan's extension tube is 4' or longer, if the fan is pivoted, if the fan is exposed to high winds, or if the fan is close to any building fixtures. Guy Wire hardware is bagged separately.
2. Safety cable is attached to extension tube.
3. Included in main hardware bag.

# 4

## Pre-Installation (cont.)

### Parts included (cont.)

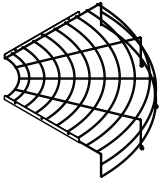
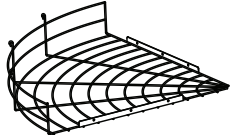
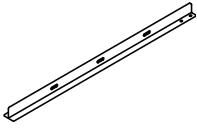
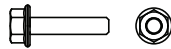
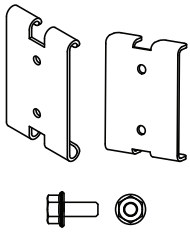
Cage					
	(4) Upper Cage Section	(4) Lower Cage Section	(4) Cage Bracket	<b>Cage Hardware</b> (56) 1/4-20 x 1" Flange Bolt (56) 1/4-20 Flange Nut	<b>Cage Clip Hardware</b> (4) Cage Clip (outer) (4) Cage Clip (inner) (8) 10-32 x 1/2" Flange Bolt (8) 10-32 Flange Nut

### Tools needed

Big Ass Fans recommends gathering the following tools prior to beginning installation.

Mechanical installation
Standard Wrench Set
Standard Socket Set with Ratchet
Torque Wrench capable of 40 ft·lb (54.2 N·m)
Phillips and Flat Head Screwdriver

Electrical installation
Phillips and Flat Head Screwdriver
7 mm Nut Driver
5/16" Nut Driver
Pair of #10 to #14AWG Strippers
Pair of Medium Size Channel Locks
Multimeter
Blue (14-18AWG) #8 Stud Ring Terminals

### Important weights

Part	Weight
Mounting kit (7/10)	32 lbs (14 kg)
Mounting kit (10/15)	37 lbs (17 kg)
Airfoils	19 lbs (9 kg)
Variable frequency drive	7 lbs (3 kg)
6-ft can cage	37 lbs (17 kg)

Part	Weight
1' Extension Tube	4 lbs (2 kg)
2' Extension Tube	8 lbs (4 kg)
3' Extension Tube	13 lbs (6 kg)
4' Extension Tube	17 lbs (8 kg)
5' Extension Tube	21 lbs (10 kg)
6' Extension Tube	25 lbs (11 kg)
7' Extension Tube	29 lbs (13 kg)
8' Extension Tube	33 lbs (15 kg)
9' Extension Tube	37 lbs (17 kg)
10' Extension Tube	42 lbs (19 kg)

## Fan diagram

- A. Safety Cable.** A redundant safety feature that secures the fan to the mounting structure. The safety cable must be installed with the fan.
- B. Upper Yoke.** Secures the fan to the mounting structure and allows the fan to adjust its center of gravity.
- C. Balance Joint.** Allows the fan to adjust its center of gravity. If the fan is not going to be pivoted, it is not necessary to install the balance joint.
- D. Extension Tube.** Extends the fan from the ceiling.
- E. Pivot Joint.** Allows the fan to be pointed in different directions. If the fan is not going to be pivoted, it is not necessary to install the pivot joint.
- F. Lower Yoke.** Allows the fan to be pivoted in different directions. Connects main fan unit assembly to mounting assembly.
- G. Motor.** See p. 1 for more information.
- H. Winglet.** Improves fan efficiency and air distribution.
- I. Airfoil.** Provides air movement. The unique patented design provides efficient and effective air movement.
- J. Cage.** (not shown): Protects the fan assembly.

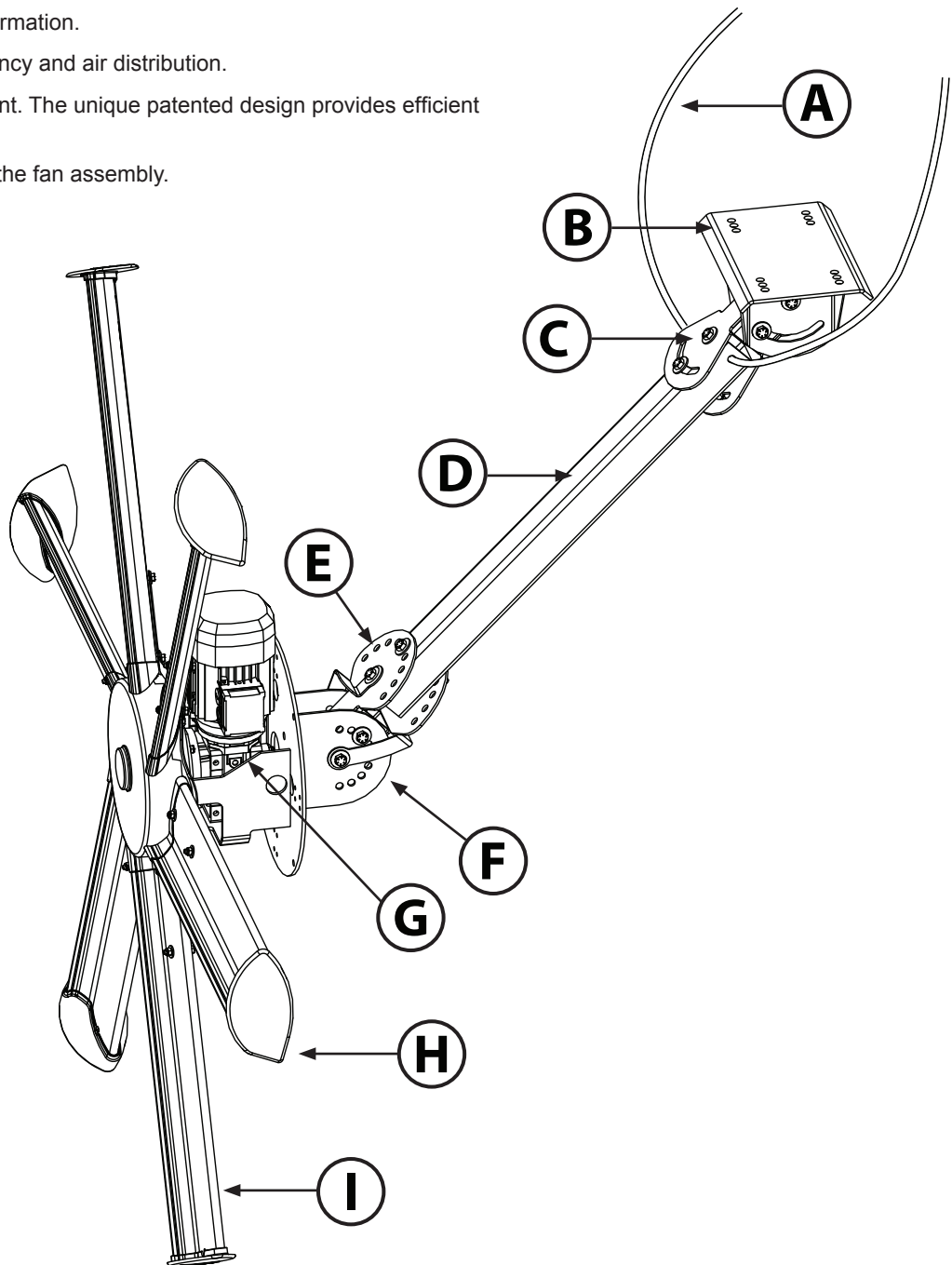

# 6

## Pre-Installation (cont.)

### Preparing the work site

Before beginning installation, review the mechanical and electrical installation guidelines below.

#### Mechanical installation

- A scissor lift or other suitable means for lifting the weight of the fan and at least two installation personnel will be required.
- Big Ass Fans can only be hung from an I-beam or angle irons. For specific requirements, see installation instructions starting on p. 8. Do not mount the fan to single purlins, trusses, or bar joists. Consult a structural engineer for installation methods not covered in this manual.

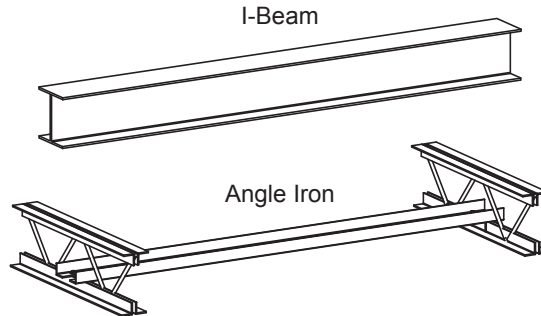

- Adhere to the safety requirements in the table below when selecting the fan location.

Safety requirement	Minimum distances
Clearance	≥ 2 ft from all fan parts. The fan installation area must be free of obstructions such as lights, cables, sprinklers, or other building structure.
Airfoil height	≥10 ft above the floor
HVAC equipment	≥1x fan diameter if at same level or above diffuser. ≥2x fan diameter if below diffuser.
Fan spacing	2.5x fan diameter, center-to-center
Radiant/IR heaters	See the manufacturer's requirements for the minimum clearance to combustibles.

#### Electrical installation

- To reduce the risk of electric shock, wiring should be performed by a qualified electrician! Incorrect assembly can cause electric shock or damage the motor and the controller!
- The installation of a Big Ass Fan must be in accordance with the National Electrical Code, ANSI/NFPA 70-2011, and all local codes.
- Refer to the Electrical Installation section in this manual for acceptable unshielded and shielded cable types.
- MC cable (stranded or solid core) may not be used for fan output/motor input leads.
- The motor leads from the fan control to the fan cannot be greater than 400 ft (121.9 m).
- The fan must be visible from its controller unless a suitable means of disconnect is used at the motor.
- The output/motor leads cannot share the same conduit or piping as the AC power supply. AC supply feeds for one fan controller may share the same conduit with AC supply feeds for one or more controllers.
- AC supply feeds for a fan controller and the output/motor leads for the same fan may not share a conduit.
- AC supply feeds for one fan controller may not share conduit with output/motor leads from one or more controllers/VFDs.
- All unused conductors that share a conduit with the AC supply feeds must be grounded on both ends.
- Controller output/motor input leads may not share a conduit with any other controller's output/motor leads.
- Controller output/motor input leads may not share a conduit with any other controller's AC supply feed.

## Pivot angle

Pivoting the fan decreases the amount of clearance the fan has from the ceiling and the floor. Before installing the fan, verify that it will have adequate clearance using the diagram below.

Observe the following safety measures when pivoting the fan:

- To pivot the fan at its maximum angle, a minimum extension tube length of 3 ft is recommended.
- The lowest moving part of the fan must be at least 10 ft (3.05 m) above the floor.
- After the fan is pivoted, there should be adequate clearance between the airfoils and any obstructions.
- Take special precaution to ensure that fan blades will be clear of safety cable and motor cable.

**Pivot Angle Diagram<sup>1</sup>**  
(with 3-ft extension tube<sup>2</sup>)

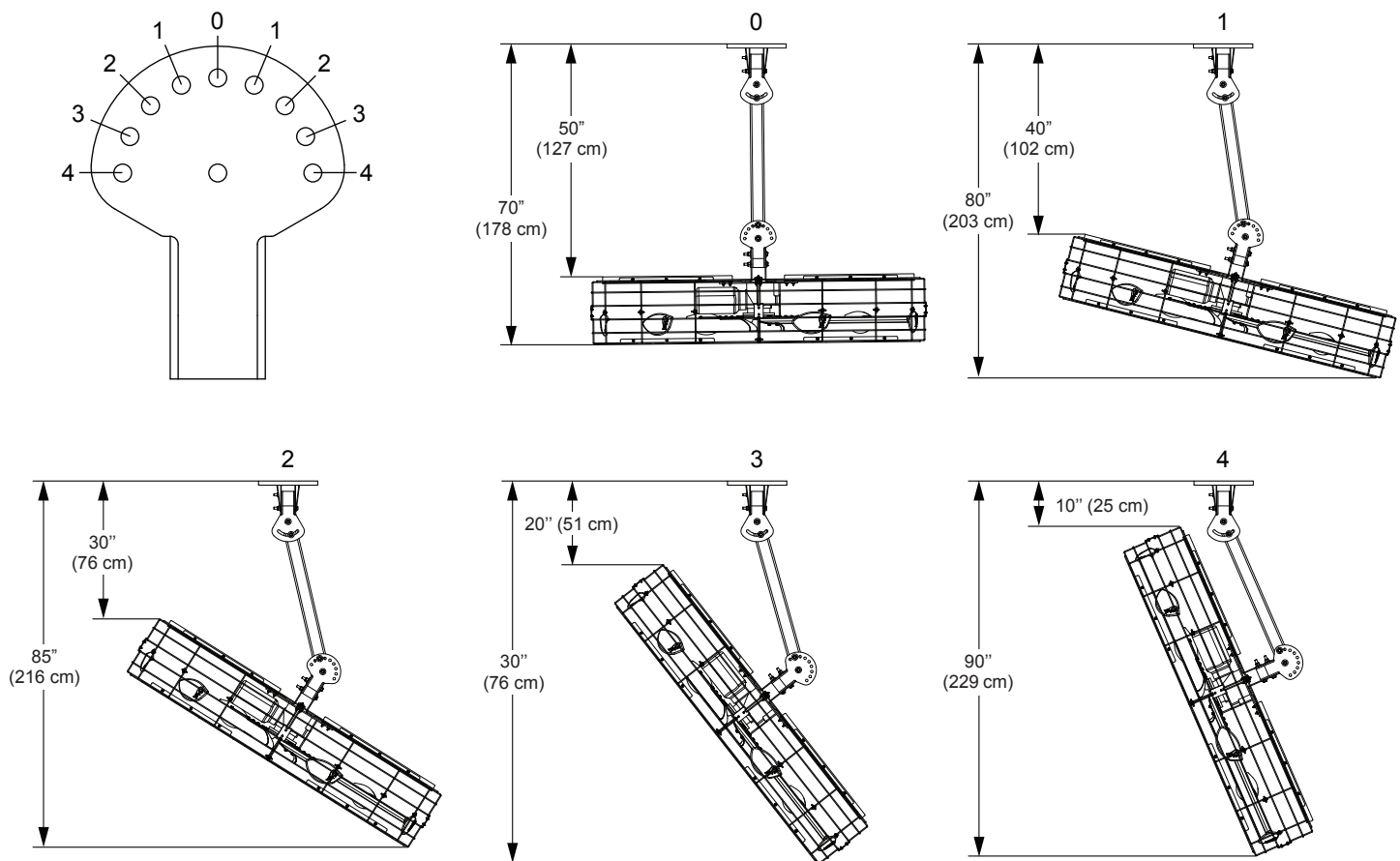

1. Measurements and angles will vary depending several factors including extension tube length and pivot configuration.
2. To estimate measurements for different extension tube lengths, add/subtract the difference in length. For example, for a 2 ft extension tube, subtract 1 ft from each measurement.

# 8 Mounting Structure: I-Beam

**Big Ass Fans can only be hung from an I-beam or bar joists. See the following page for bar joist mounting instructions. Consult a structural engineer for installation methods not covered in this manual.**

- ⚠ WARNING:** The following instructions assume that the customer's roof structure from which the fan will be hung is of sound construction, undamaged, and capable of supporting loads of up to 645 lbs (293 kg). It is the sole responsibility of the customer to verify that the roof structure is adequate for fan installation. Big Ass Fans recommends consulting a structural engineer prior to fan installation.
- ⚠ CAUTION:** It is not recommended to mount a Big Ass Fan from a fabricated I-beam.
- ⚠ CAUTION:** Install the spacers only if the thickness of the I-beam flange exceeds 3/8" (1cm). The mounting holes on the spacer are closer to one side than the other. Make sure this side is facing the I-beam.

## 1. Attach upper yoke (to I-beam)

Measure the flange width of the I-beam from which the fan will be hung. Consult the tables and diagram below to determine what size upper yoke is included with your fan package. Select the upper yoke mounting holes that match the flange width of the I-beam.

Secure the upper yoke to the I-beam with the Beam Clip Hardware as shown. Tighten the bolts to **40 ft·lb (54.2 N·m)** using a torque wrench and 3/4" socket.

Proceed to "Hanging the Fan" (p. 14).

### Beam Clip Hardware (BAF-Supplied):

- a. (4) 1/2-13 x 2" GR 8 Bolt
- b. (8) 1/2" Flat Washer
- c. (4) 1/2-13 Nylock Nut
- d. (2) Beam Clip
- e. (2) Spacer

**Small Upper Yoke**  
13-3/4" (349 mm) x 10" (258 mm)

I-beam flange width	Upper yoke mounting holes
5" (127 mm) to 6-5/8" (168 mm)	Inner holes
>6-5/8" (168 mm) to 8-1/4" (210 mm)	Middle holes
>8-1/4" (210 mm) to 9-7/8" (250 mm)	Outer holes

outer holes  
middle holes  
inner holes

**Upper Yoke**  
(top view)

**Large Upper Yoke**  
18-1/2" (470 mm) x 10" (258 mm)

I-beam flange width	Upper yoke mounting holes
9-7/8" (250 mm) to 11-3/8" (289 mm)	Inner holes
>11-3/8" (289 mm) to 13" (330 mm)	Middle holes
>13" (330 mm) to 14-5/8" (371 mm)	Outer holes

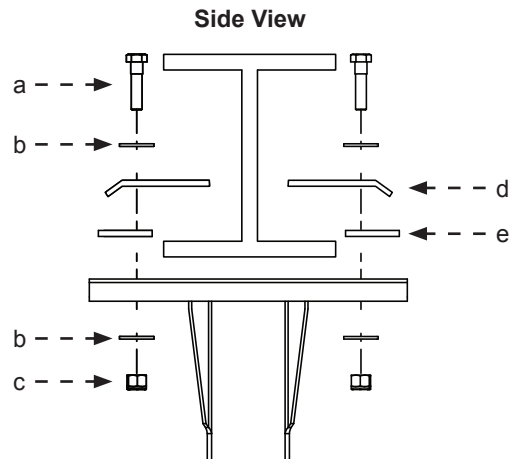
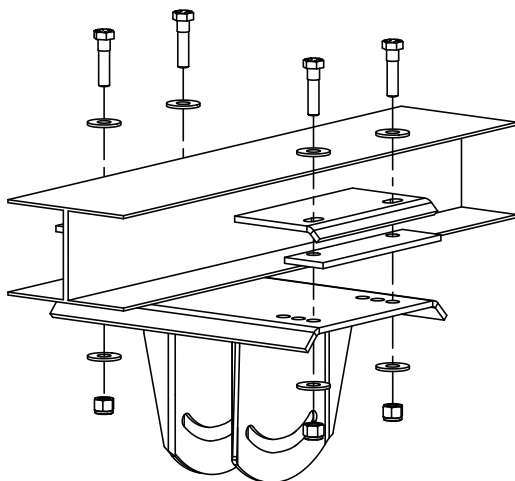

# Mounting Structure: Bar Joists

**If you are installing the fan to an I-beam and have attached the upper yoke (p. 8), proceed to “Hanging the Fan” (p. 14).**

- ⚠ WARNING:** The following instructions assume that the customer’s roof structure from which the fan will be hung is of sound construction, undamaged, and capable of supporting loads of the fan and its method of attachment. It is the sole responsibility of the customer to verify that the roof structure is adequate for fan installation. Big Ass Fans recommends consulting a structural engineer prior to fan installation.
- ⚠ WARNING:** Never use beam clamps when mounting the fan to angle irons! Beam clamps are only intended for I-beam installations.
- ⚠ CAUTION:** Do not install the fan from a single purlin, truss, or bar joist.
- ⚠ CAUTION:** Unsupported angle iron spans should not exceed 12 ft (3.7 m).
- ⚠ CAUTION:** The angle irons must be fastened to the roof structure at each end.

## 1. Select proper angle irons

Follow the table below when selecting angle irons for fan installation.

*Note: Angle irons and angle iron hardware are not included with the fan.*

Angle iron span (between mounting points)	Minimum angle iron dimensions (W x H x T)	Number of angle irons needed
6 ft (1.8 m) or less	2.5" (6.4 cm) x 2.5" (6.4 cm) x 0.25" (0.6 cm)	2
over 6 ft (1.8 m) to 8 ft (2.4 m)	3" (7.6 cm) x 3" (7.6 cm) x 0.25" (0.6 cm)	2
over 8 ft (2.4 m) to 12 ft (3.7 m)	3" (7.6 cm) x 3" (7.6 cm) x 0.25" (0.6 cm)	4*

\*2 pairs of angle irons. Pairs should be placed back to back and fastened in center (see step 3).

**Angle Iron Side View**  
(see table for dimensions)

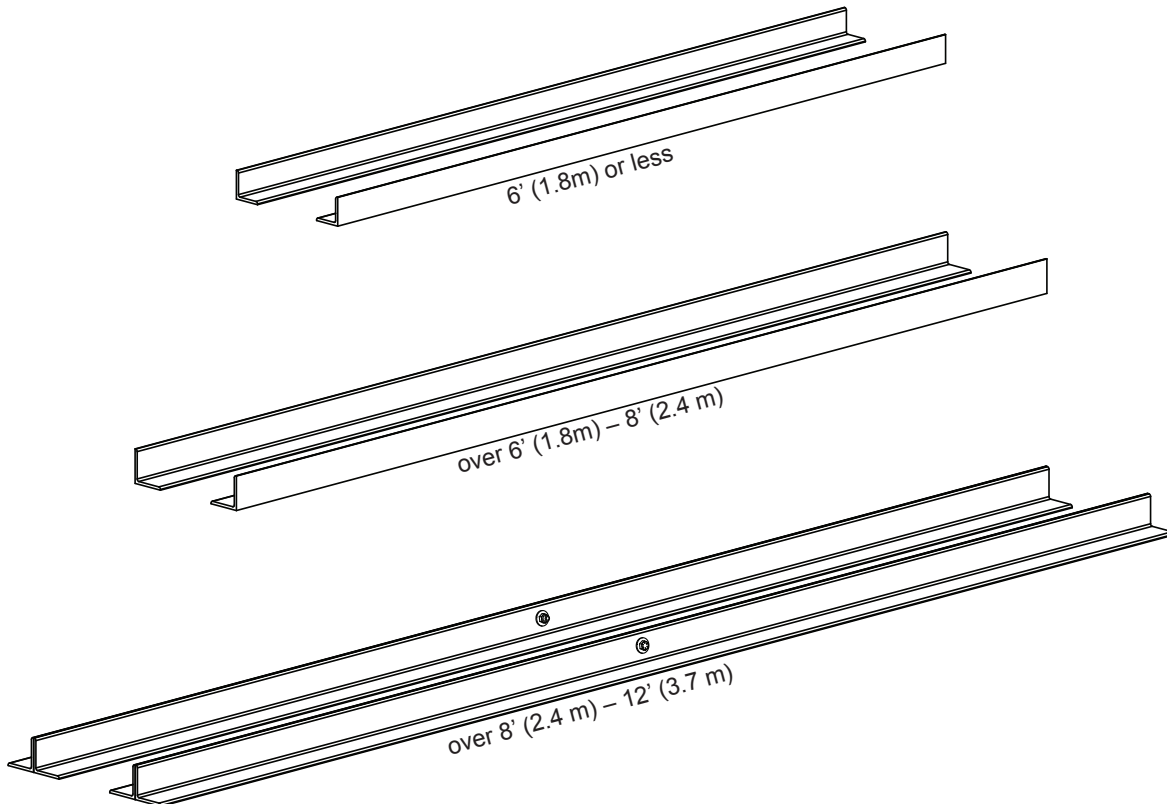
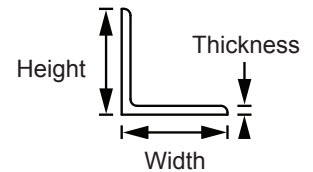

## 10

## Mounting Structure: Bar Joists (cont.)

## 2. Pre-drill angle irons

Drill two  $\varnothing 9/16"$  (1.4 cm) holes exactly  $5\ 3/8"$  (13.7 cm) apart in the centers of two angle irons.

Measure the distance between the mounting points of the roof structure that the angle irons will span. Measure the same distance on the angle irons and drill  $\varnothing 9/16"$  (1.4 cm) holes through each end of the angle irons. Drill holes in two angle irons if span is 8 ft (2.4 m) or less. Drill holes in four angle irons if span is greater than 8 ft (2.4 m).

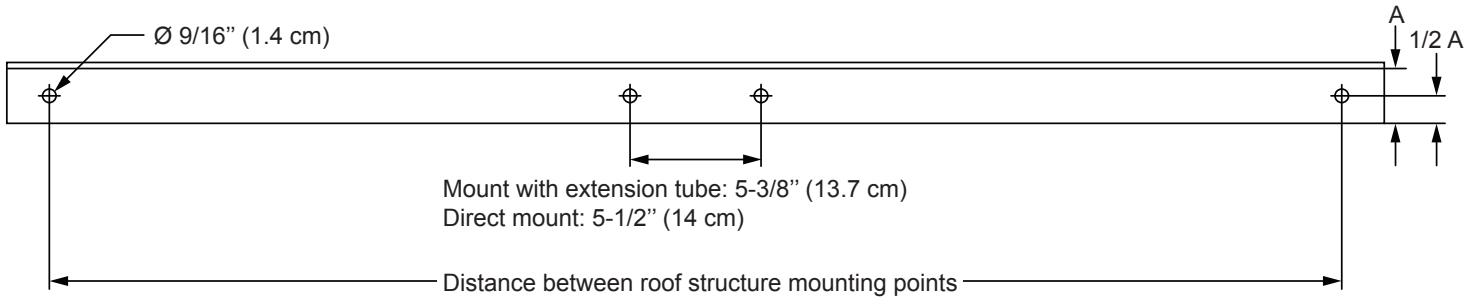

## 3. Fasten angle irons together (if span is longer than 8 ft)

**If the angle iron span is 8 ft (2.4 m) or less, proceed to step 4a on the following page.**

If the angle iron span is longer than 8 ft (2.4 m), it is necessary to use double angle irons.

Locate the center of the angle iron length. Drill  $\varnothing 9/16"$  (1.4 cm) hole through the center of the vertical wall of the angle iron. Drill a total of four angle irons.

Place two drilled angle irons back to back. Fasten the angle irons together with customer-supplied Grade 8 hardware. Align the angle irons to each other and tighten the bolts to **40 ft·lb (54.2 N·m)** using a  $3/4"$  socket with torque wrench.

Repeat step for remaining two angle irons.

**Proceed to step 4b.**

**Grade 8 Hardware (Customer-Supplied):**

- a. (2)  $1/2$  -13 Bolt
- b. (4)  $1/2"$  Washers
- c. (2)  $1/2$ -13 Nylock Nut

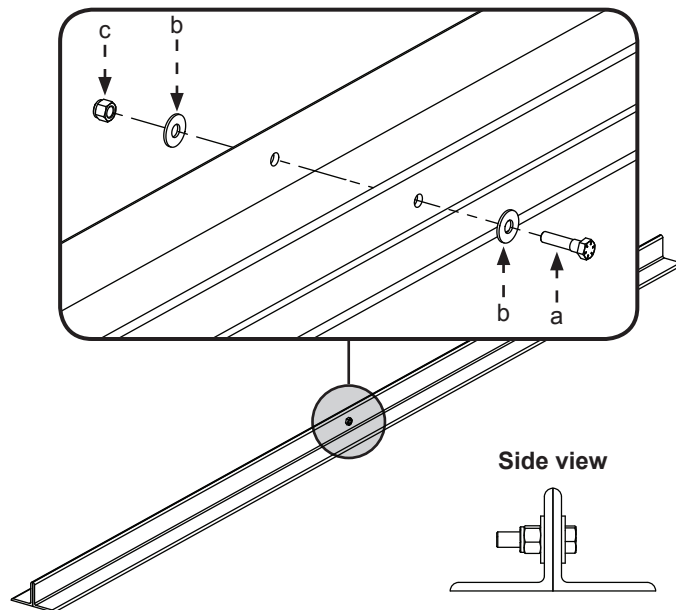

#### 4a. Fasten single angle irons to roof structure mounting points

**If installation requires double angle irons (i.e., span is greater than 8 ft [2.4m]), proceed to step 4b.**

Fasten the angle irons to the roof structure mounting points at each end with customer-supplied Grade 8 hardware as shown. *Do not tighten the hardware until the fan has been mounted to the angle irons.*

Proceed to step 5.

##### Grade 8 Hardware (Customer-Supplied):

- a. (4) 1/2-13 Bolt
- b. (8) 1/2" Washer
- c. (4) 3" Square Washer (BAF Supplied; see diagram)
- d. (4) 1/2-13 Nylock Nut

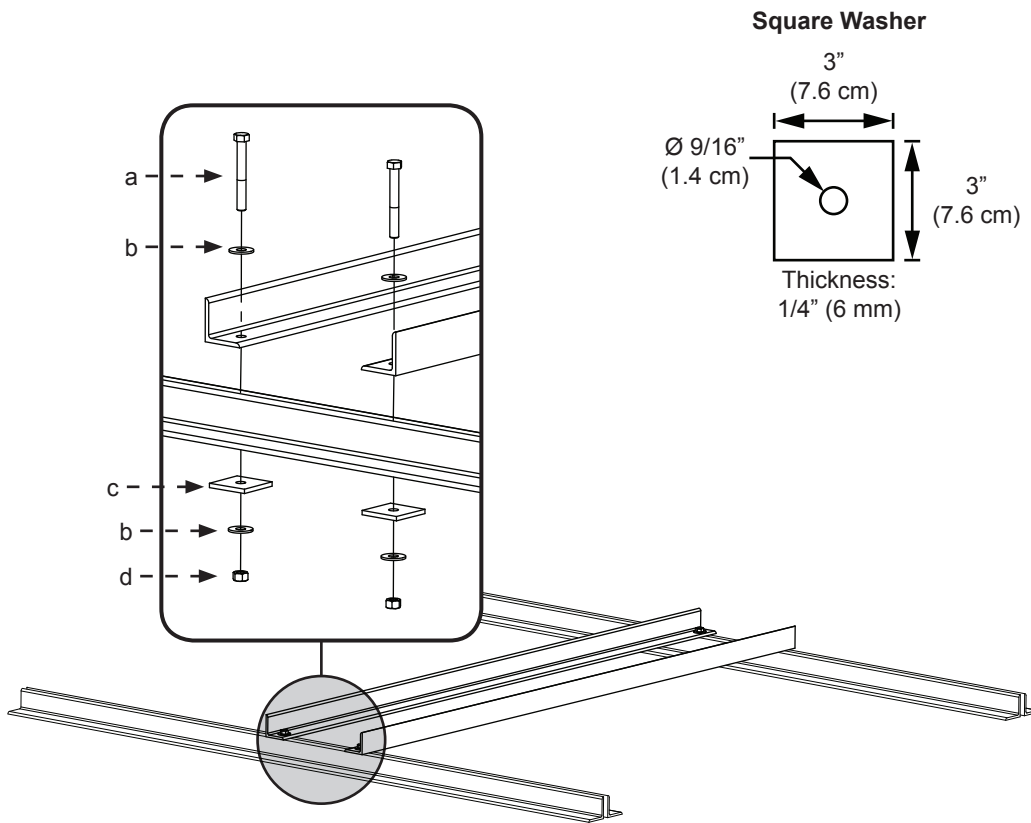

#### 4b. Fasten double angle irons to roof structure mounting points

Fasten the angle irons to the roof structure mounting points at each end with customer-supplied Grade 8 hardware as shown. The angle irons with fan mounting holes should be positioned on the inside, facing each other. *Do not tighten the hardware until the fan has been mounted to the angle irons.*

##### Grade 8 Hardware (Customer-Supplied):

- a. (8) 1/2-13 Bolt
- b. (16) 1/2" Washer
- c. (8) 3" Square Washer (BAF-Supplied; see diagram)
- d. (8) 1/2-13 Nylock Nut

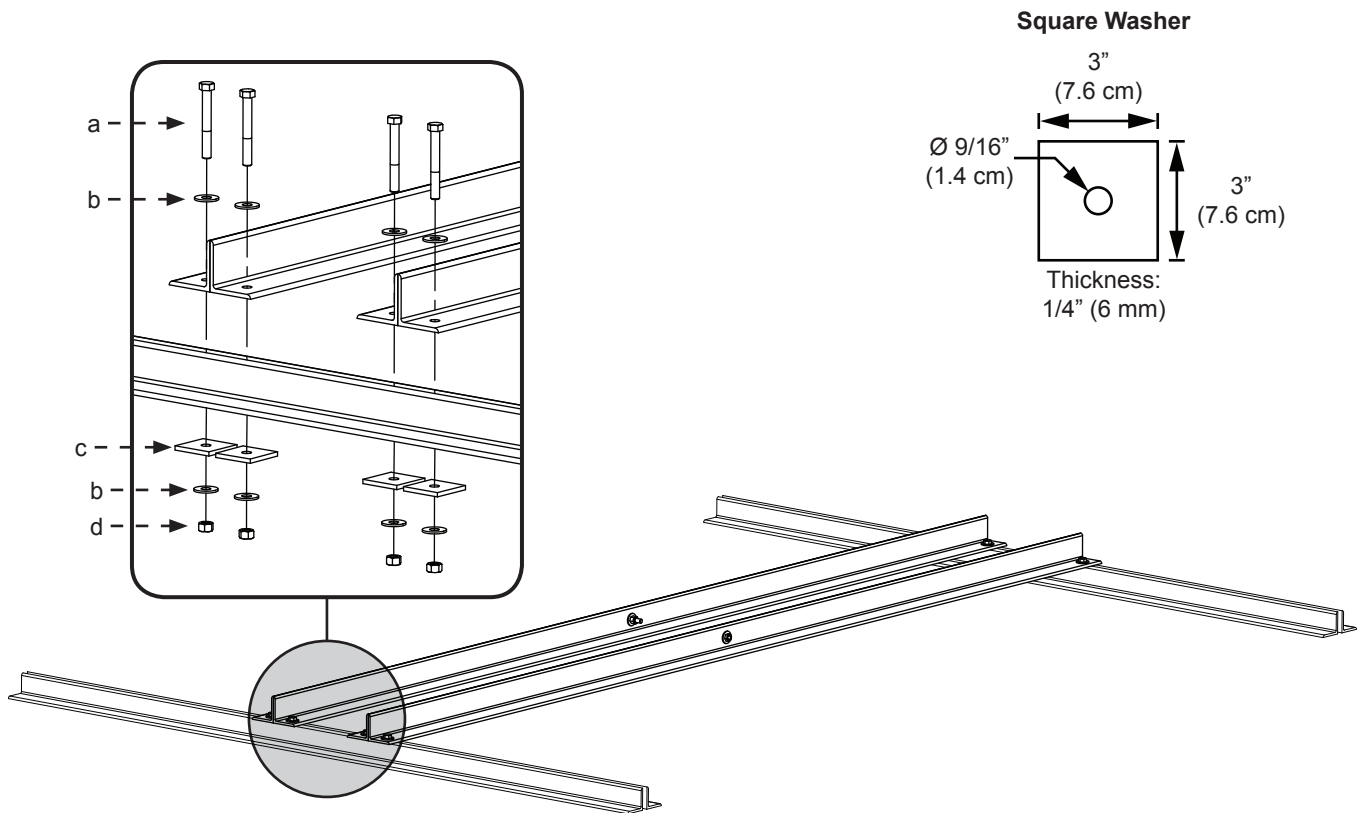

## 5. Attach upper yoke (to angle irons)

Secure the upper yoke directly to the angle irons with the Beam Clip Hardware as shown. The angle irons should be aligned with the outermost holes of the upper yoke. Consult the diagrams below for distances between the angle irons.

Tighten the bolts to **40 ft·lb (54.2 N·m)** using a torque wrench and 3/4" socket. After attaching the upper yoke to the angle irons, tighten all the bolts securing the angle irons to the roof structure to **40 ft·lb (54.2 N·m)**.

Proceed to "Hanging the Fan" (p. 14).

### Beam Clip Hardware (BAF-Supplied):

- (4) 1/2-13 x 2" GR 8 Bolt
- (8) 1/2" Flat Washer
- (4) 1/2-13 Nylock Nut

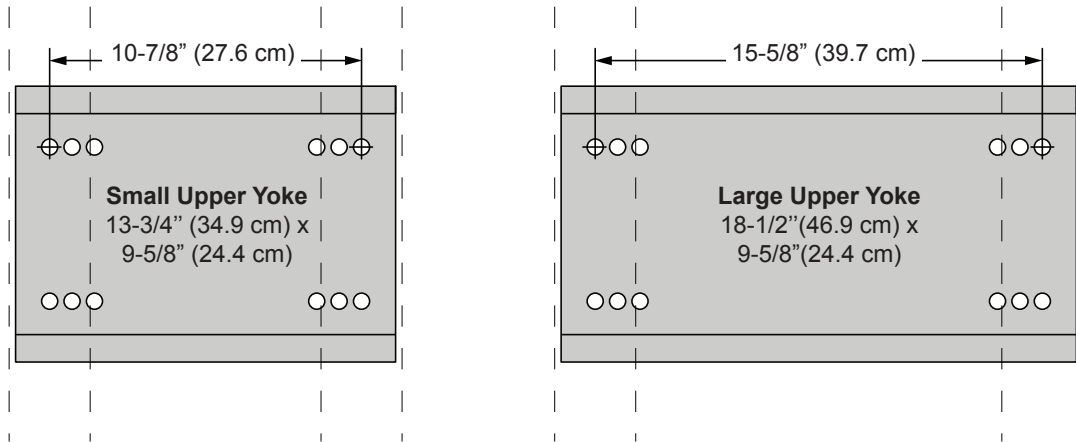

Note: Dashed lines represent angle irons in the above illustrations.

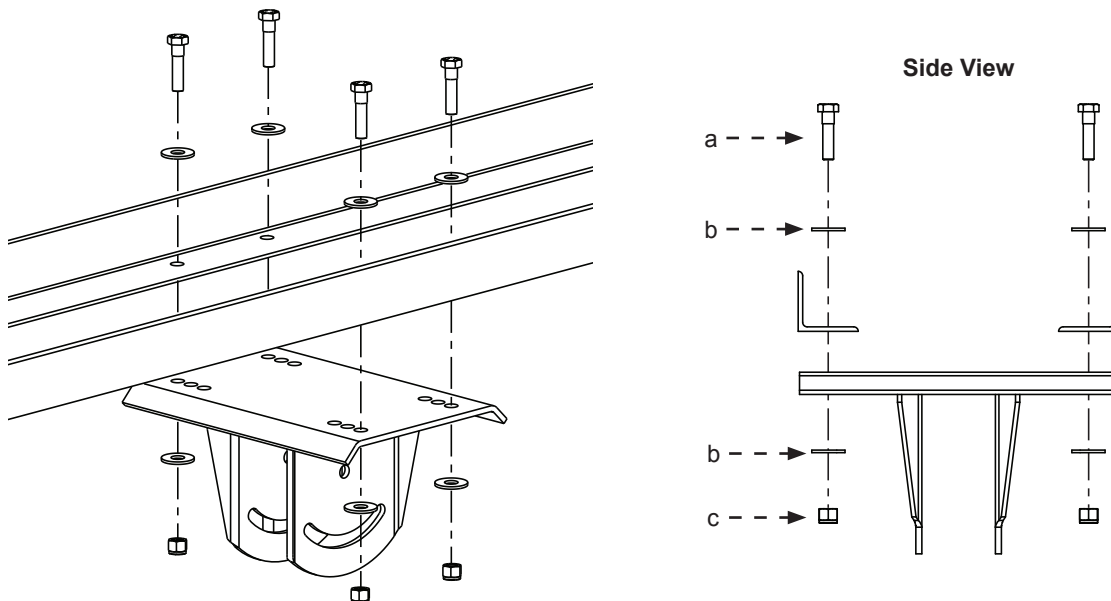

## 14

## Hanging the Fan

## 1. Attach balance joint (to upper yoke)

If the fan will not be pivoted, it is not necessary to install the balance joint. Skip this step and proceed to Step 2b.

Fasten the balance joint to the upper yoke (already attached to mounting structure) using the Balance/Pivot Hardware as shown. Hand-tighten the bolts.

The fan's balanced position can change depending on the pivot angle of the fan or the angle of the roof. For this reason, do not fully tighten these bolts until the fan is completely assembled.

**Balance/Pivot Hardware:**

- a. (2) 1/2-13 x 5" GR 8 Bolt
- b. (4) 1/2" Flat Washer
- c. (2) 1/2-13 Nylock Nut

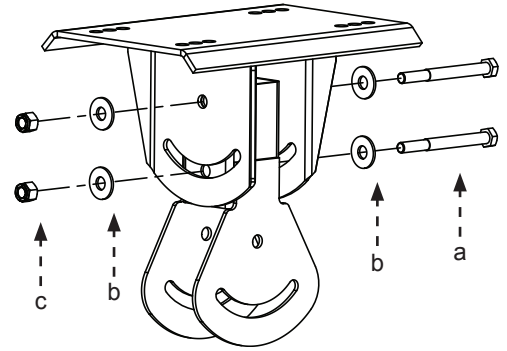

Do not fully tighten bolts until fan is completely assembled!

## 2a. Attach extension tube (to balance joint)

Fasten the extension tube to the balance joint with the Extension Tube Hardware as shown. Hand-tighten the bolts.

The fan's balanced position can change depending on the pivot angle of the fan or the angle of the roof. For this reason, do not fully tighten these bolts until the fan is completely assembled.

**Proceed to Step 3.****Extension Tube Hardware:**

- a. (2) 1/2-13 x 4-1/2" GR 8 Bolt
- b. (4) 1/2" Flat Washer
- c. (2) 1/2-13 Nylock Nut

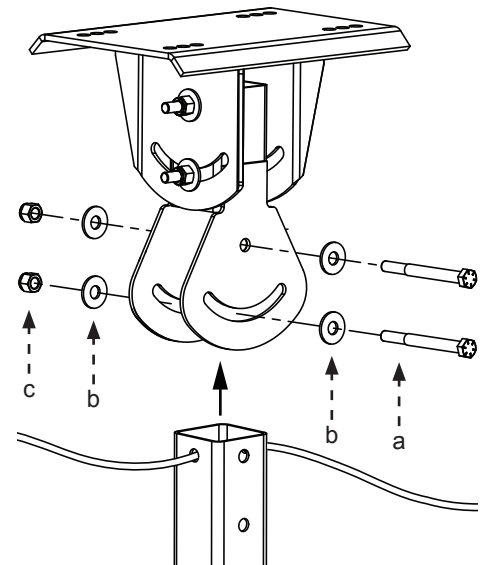

Do not fully tighten bolts until fan is completely assembled!

## 2b. Attach extension tube (to upper yoke)

Fasten the extension tube to the upper yoke with the Extension Tube Hardware as shown.

Before tightening the bolts, allow the extension tube to hang freely and balance itself. Tighten the bolts to **40 ft·lb (54.2 N·m)** using a torque wrench and 3/4" socket.

**Extension Tube Hardware:**

- a. (2) 1/2-13 x 4-1/2" GR 8 Bolt
- b. (4) 1/2" Flat Washer
- c. (2) 1/2-13 Nylock Nut

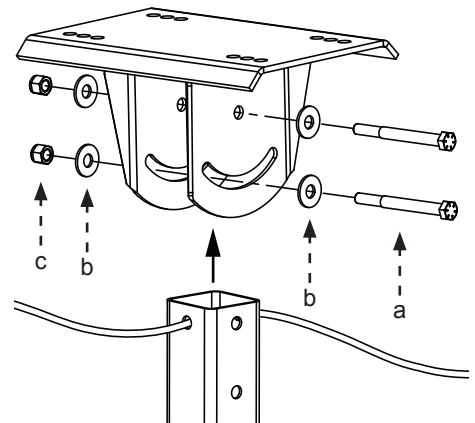

### 3. Secure upper safety cable

The safety cable is a crucial part of the fan and must be installed correctly. If you have questions, call Customer Service for assistance.

Secure the safety cable to the I-beam or angle iron by wrapping the safety cable around it and securing the looped ends with the shackle as shown. The cable must be drawn tightly around the I-beam or angle iron, leaving as little slack as possible. If possible, the shackle should be on the topside of the I-beam or angle iron. Securely tighten the shackle.

I-Beam Mount

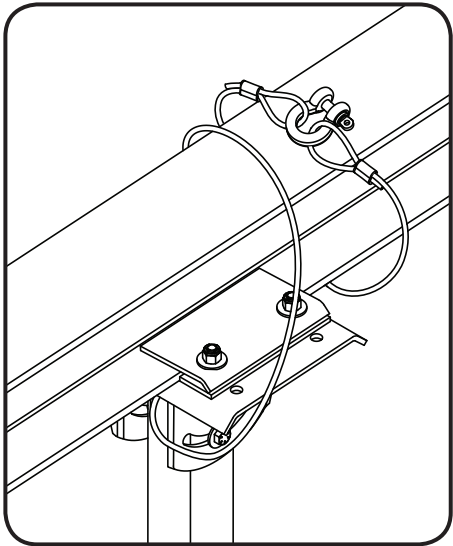

Shackle

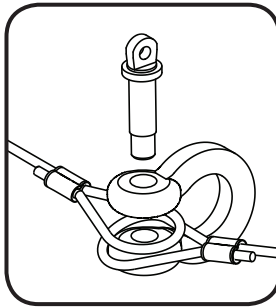

Angle Iron Mount

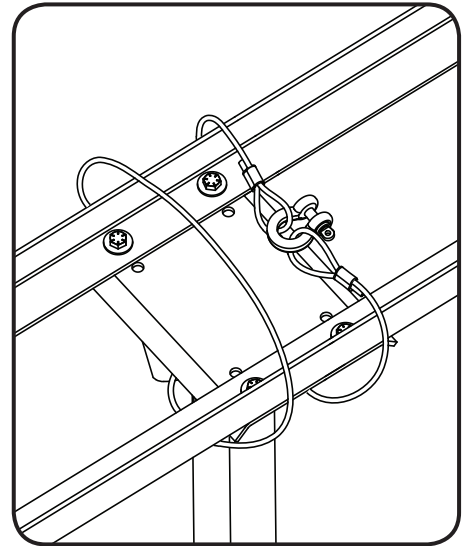

### 4. Attach main fan unit (to lower yoke)

**CAUTION:** When the fan is pivoted, the motor should never be lower than the gearbox. This will protect the motor in case the gearbox leaks. Consider how the fan will eventually be pivoted and position the lower yoke accordingly.

Attach the main fan unit to the lower yoke with the Main Fan Unit Hardware as shown.

Tighten the bolts to **40 ft·lb (54.2 N·m)** using a torque wrench and 3/4" socket.

**Main Fan Unit Hardware:**

- a. (4) 1/2-13 x 1-3/4" GR 8 Bolt
- b. (8) 1/2" Flat Washer
- c. (4) 1/2-13 Nylock Nut

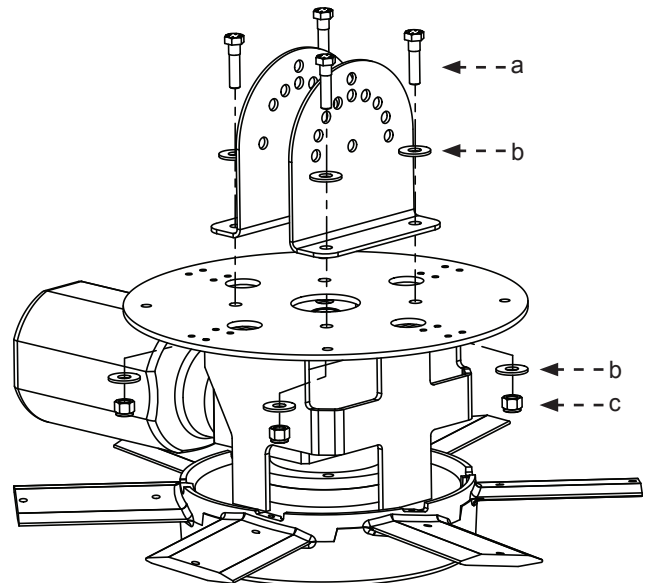

## 5. Attach pivot joint

If the fan will not be pivoted, it is not necessary to install the pivot joint. Skip this step and proceed to Step 6b.

**CAUTION:** Install the bolts exactly as shown. Do not pivot the fan until it has been completely assembled.

Fasten the mount brackets and pivot joint to the extension tube with the Balance/Pivot Hardware as shown. Hand-tighten the bolts.

### Balance/Pivot Hardware:

- a. (2) 1/2-13 x 5" GR 8 Bolt
- b. (4) 1/2" Flat Washer
- c. (2) 1/2-13 Nylock Nut

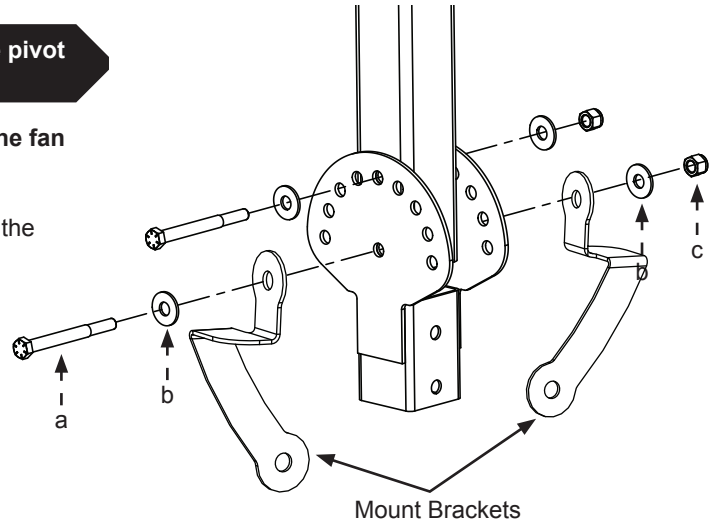

**Do not fully tighten bolts until fan is completely assembled!**

## 6a. Attach lower yoke (to pivot joint)

**CAUTION:** When the fan is pivoted, the motor should never be lower than the gearbox. This will protect the motor in case the gearbox leaks. Consider how the fan will eventually be pivoted and position the motor accordingly.

**CAUTION:** Install the bolts exactly as shown. Do not pivot the fan until it has been completely assembled.

**CAUTION:** The motor frame is heavy. Use care when raising it.

Fasten the lower yoke and motor frame to the pivot joint with the Lower Yoke Hardware as shown. Hand-tighten the bolts.

Proceed to Step 7.

### Lower Yoke Hardware:

- a. (2) 1/2-13 x 4-1/2" GR 8 Bolt
- b. (4) 1/2" Flat Washer
- c. (2) 1/2-13 Nylock Nut

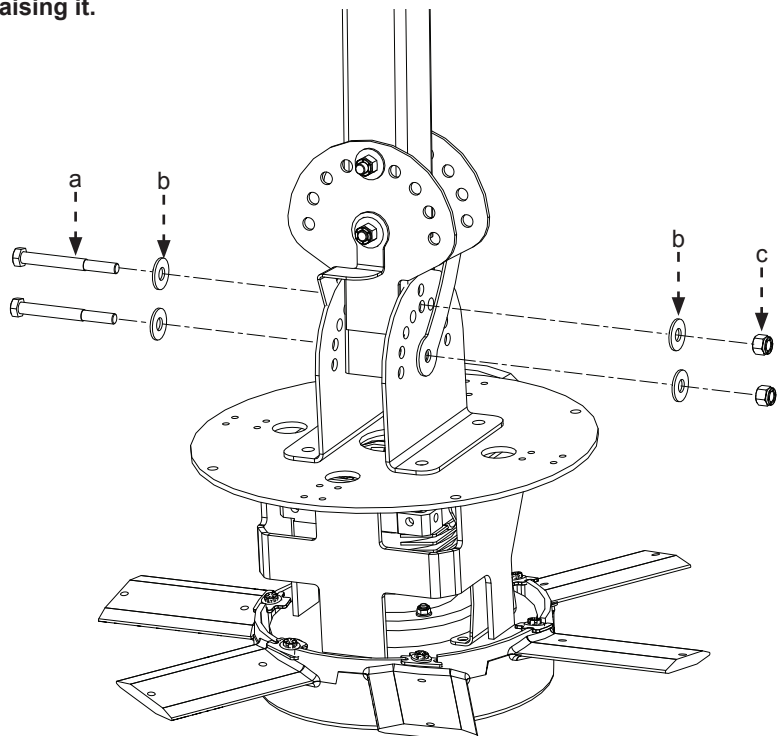

**Do not fully tighten bolts until fan is completely assembled!**

## 6b. Attach lower yoke (to extension tube)

**⚠ CAUTION:** The motor frame is heavy. Use care when raising it.

Fasten the lower yoke and motor frame to the bottom of the extension tube with the Lower Yoke Hardware as shown.

**The lower yoke can only be attached to the extension tube through the topmost and bottommost holes on the lower yoke.**

### Lower Yoke Hardware:

- a. (2) 1/2-13 x 4-1/2" GR 8 Bolt
- b. (4) 1/2" Flat Washer
- c. (2) 1/2-13 Nylock Nut

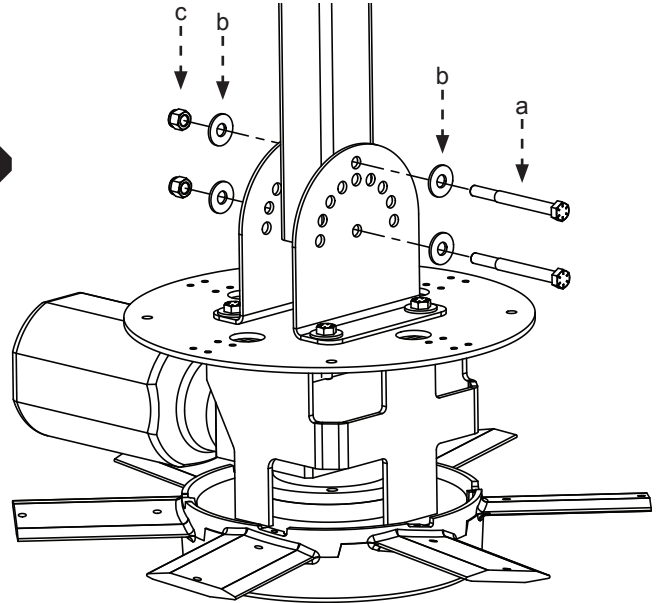

## 7. Attach center cap

Snap the center cap onto the bottom of the main fan unit.

Proceed to "Installing Airfoils" on the following page.

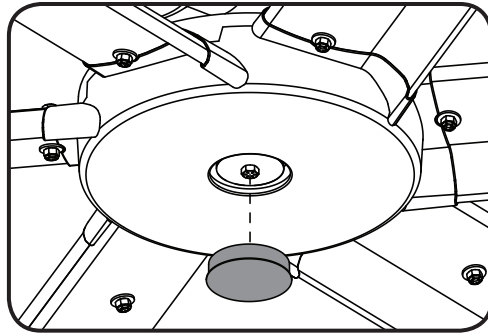

## 18

## Installing Airfoils

## 1. Attach winglets

Attach the winglets to the ends of the airfoils with the Winglet Hardware as shown. Use a Phillips head and standard screwdriver to secure the fastener.

Attach winglets to all six (6) airfoils before attaching airfoils to fan.

**Winglet Hardware:**

- a. (6) 10-24 x 1/2" Bolt
- b. (6) 10-24 x 3/4" Barrel

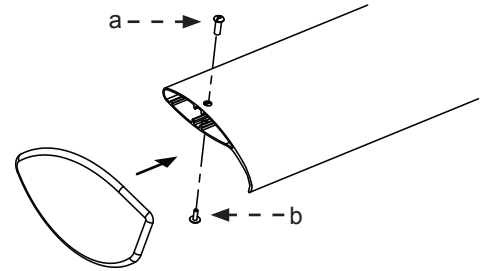

## 2. Position airfoils and trim

Slide the airfoil trim and airfoil onto the tab as shown. An airfoil will only attach to the fan hub in one direction. Forcing an airfoil into place could damage it.

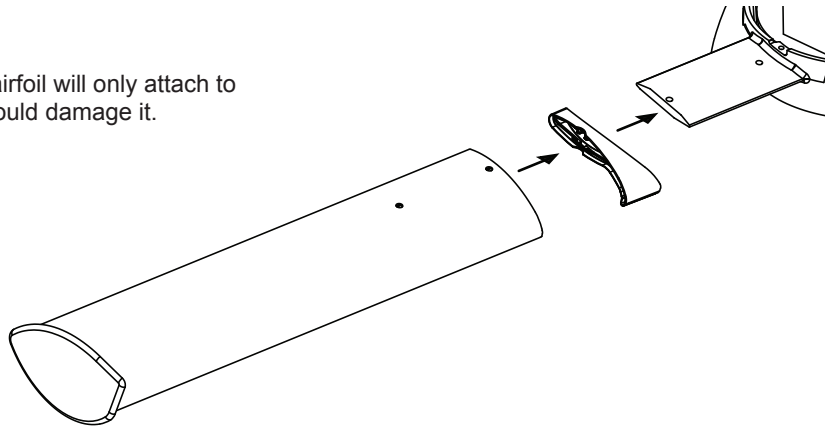

## 3. Attach airfoil retainers

Attach the six (6) airfoil retainers using the Airfoil Hardware as shown.

Moving clockwise around the fan hub, position the airfoil retainers end over end. Hole A of the retainer should be positioned over top of Hole B. *Do not tighten the bolts until all the airfoil retainers have been attached!*

Tighten all the bolts on the airfoil retainers to **29 ft·lb (39.3 N·m)** using a torque wrench and 1/2" socket.

**Airfoil Hardware:**

- a. (12) 5/16"-18 x 2-1/4" GR 8 Bolt
- b. (36) 5/16" Flat Washer
- c. (12) 5/16"-18 Nut

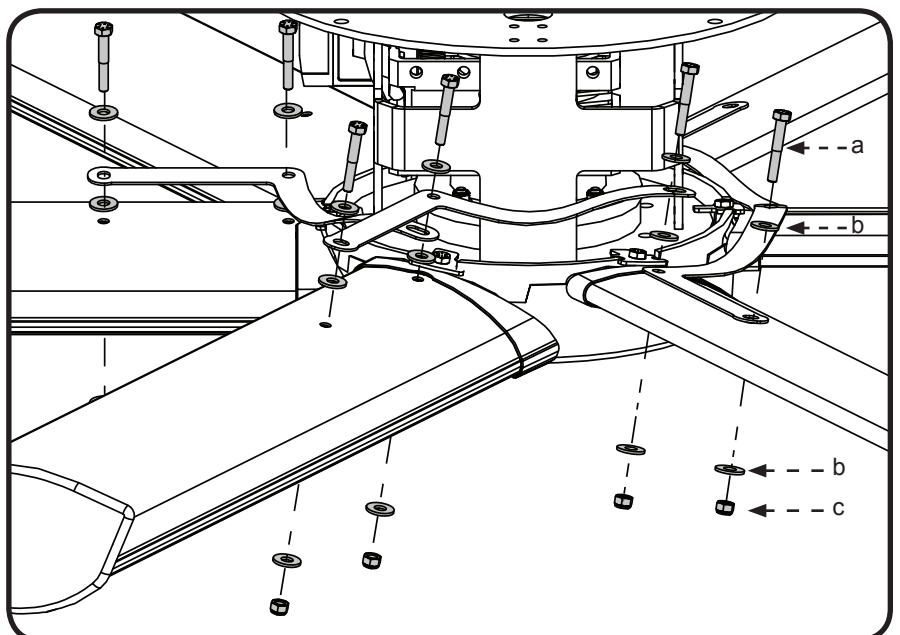
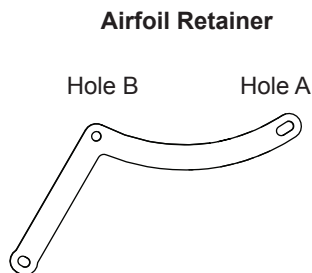

# Installing Cage

## 1. Attach cage bracket

Attach the four (4) cage brackets with the Cage Hardware as shown.

### Cage Hardware:

- a. (16) 1/4-20 x 1" Flange Bolt
- b. (16) 1/4-20 Flange Nut

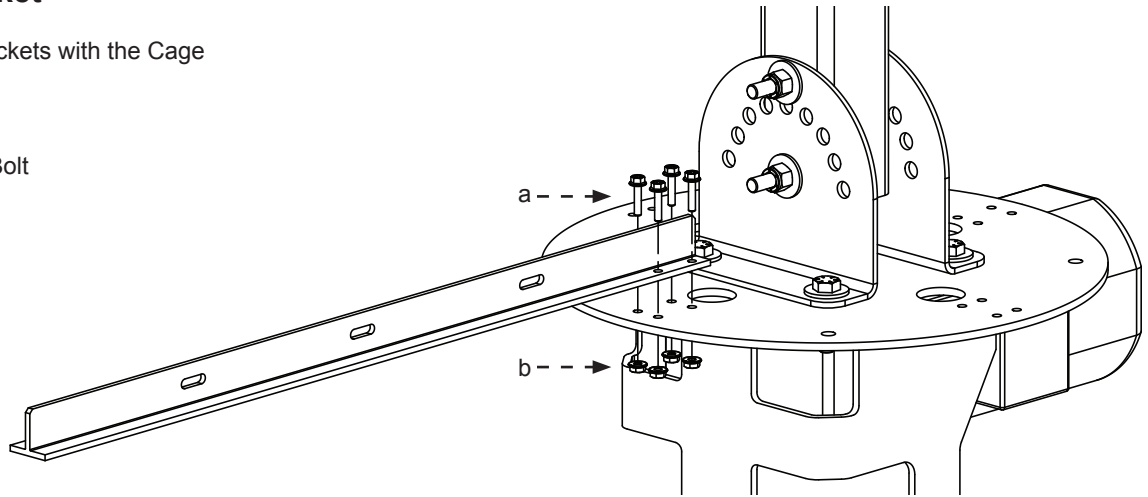

## 2. Attach upper cage

Attach the upper cage to the cage brackets using the Cage Hardware as shown. Torque the bolts to **10 ft·lb (13.6 N·m)**.

Install one section at a time. Use the cage brackets to support sections during hardware installation. Make sure the bolts secure adjacent sections.

### Cage Hardware:

- a. (12) 1/4-20 x 1" Flange Bolt
- b. (12) 1/4-20 Flange Nut

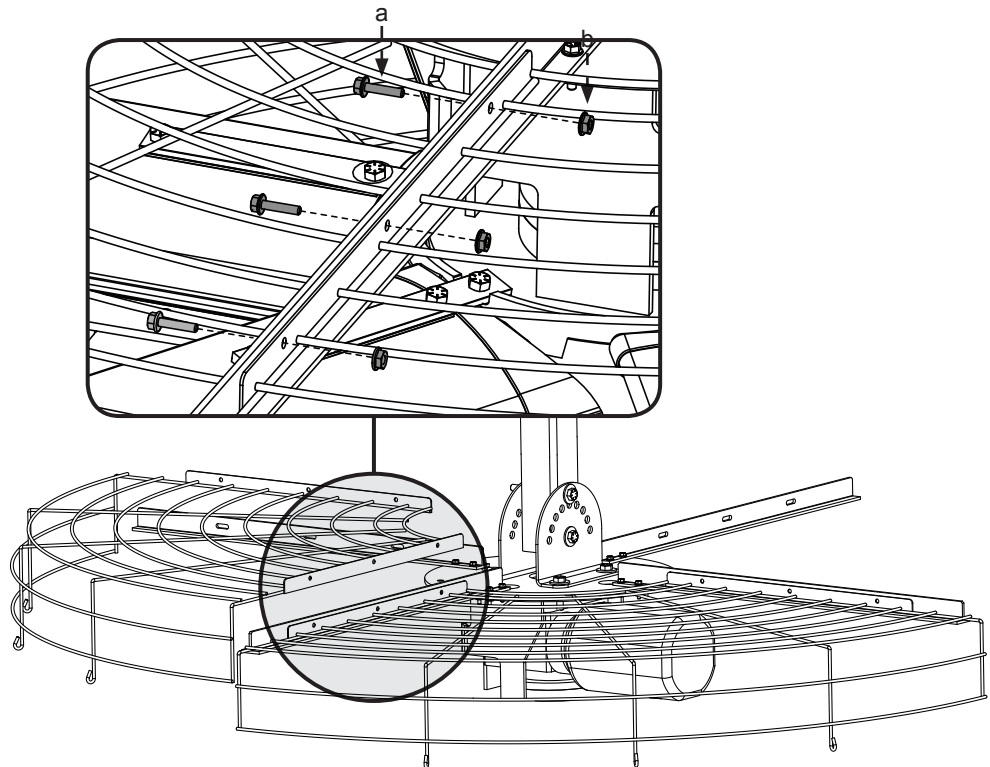

### 3. Attach lower cage sections (to upper cage)

Use two (2) outer cage clips (one on each end) to hang a lower cage section from the upper cage.

Secure the lower cage section to the upper cage using the Cage Hardware as shown.

Repeat this step for the other cage sections. Make sure to secure adjacent sections first.

#### Cage Hardware:

- a. (12) 1/4-20 x 1" Flange Bolt
- b. (12) 1/4-20 Flange Nut

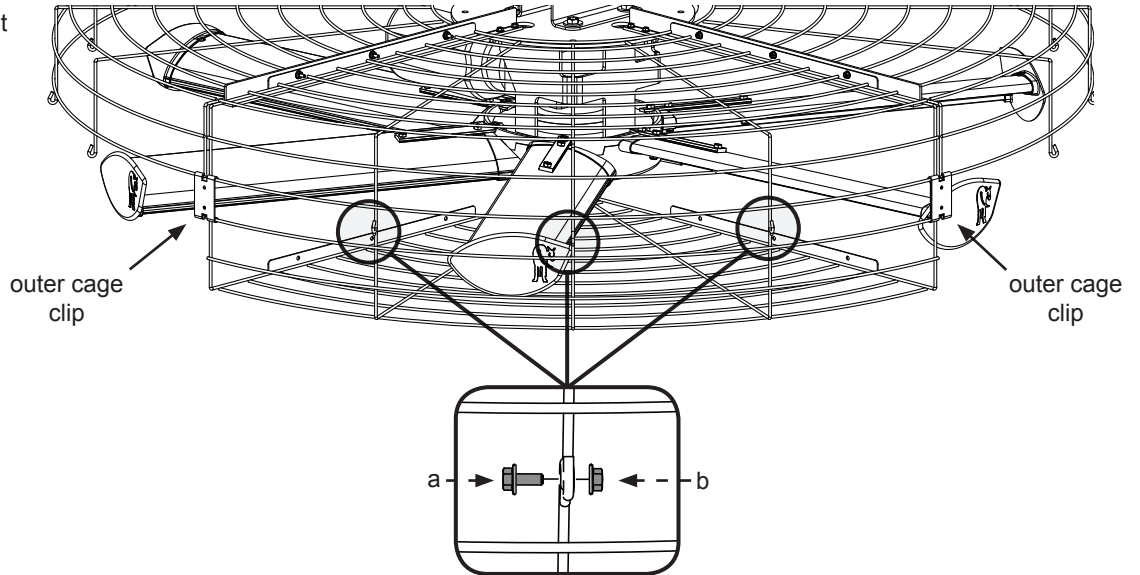

### 4. Secure lower cage

Fasten the lower cage sections to each other using the Cage Hardware (1/4-20 bolts and nuts) as shown. Torque the bolts to **10 ft·lb (13.6 N·m)**.

Attach the inner cage clips to the outer cage clips using the Cage Clip Hardware (10-32 bolts and nuts) as shown.

#### Cage and Cage Clip Hardware :

- a. (12) 1/4-20 x 1" Flange Bolt
- b. (12) 1/4-20 Flange Nut
- c. (8) 10-32 x 1/2" Flange Bolt
- d. (8) 10-32 Flange Nut

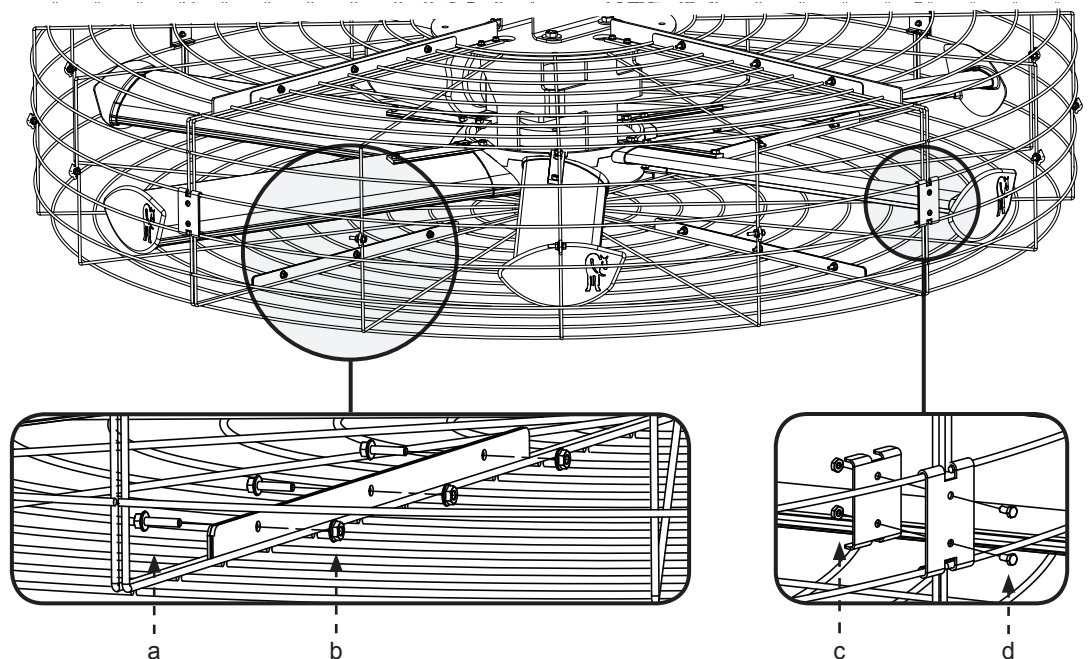

# Pivoting the Fan

21

If you are not pivoting the fan, proceed to “Installing Guy Wires” on the following page.

## 1. Adjust pivot joint and lower yoke

- ⚠ **WARNING:** Do not remove the bottom bolt of the pivot joint or the bottom bolt of the lower yoke.
- ⚠ **CAUTION:** When the fan is pivoted, the motor should not be lower than the gearbox (see pp. 16–17).
- ⚠ **WARNING:** Before tightening the bolts, make sure the fan blades are clear of any obstructions including the safety cable and motor power cable.

Using caution, change the hole of the top bolt (A) on the pivot joint and/or the top bolt (B) on the lower yoke to pivot the direction of the fan. **Remove only one bolt at a time.**

When satisfied with the angle of pivot, tighten all the bolts on the pivot joint and the lower yoke. Tighten the bolts to **40 ft·lb (54.2 N·m)** using a torque wrench and 3/4” socket.

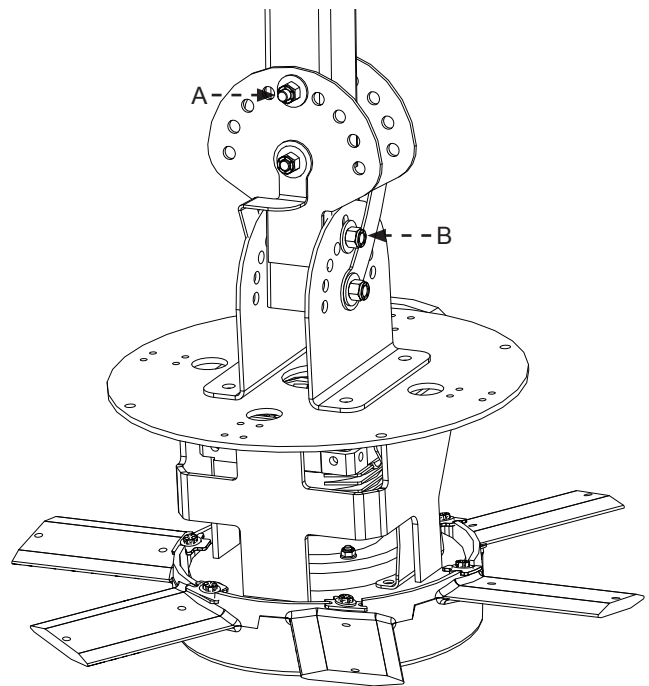

## 2. Tighten bolts on upper yoke and balance joint

Tighten the four (4) bolts on the upper yoke and the balance joint. Before tightening the bolts, let the fan hang freely so it can adjust its center of gravity.

Tighten the bolts to **40 ft·lb (54.2 N·m)** using a torque wrench and 3/4” socket.

Proceed to “Installing Guy Wires” on the following page.

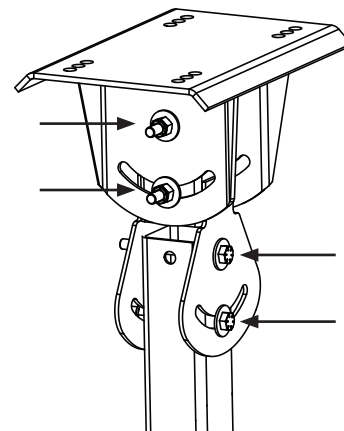

# Installing Guy Wires

**Guy wire installation is recommended if the fan's extension tube is 4 ft (1.2 m) or longer, if the fan is pivoted, if the fan is exposed to high winds, or if the fan is close to any building fixtures.**

## 1. Attach eyebolt to motor frame

Attach the large eyebolt to the motor frame with the Guy Wire Hardware as shown.

### Guy Wire Hardware:

- a. (1) 3/8-16 x 1" Eyebolt
- b. (2) 3/8" Washer
- c. (1) 3/8-16 Nylock Nut

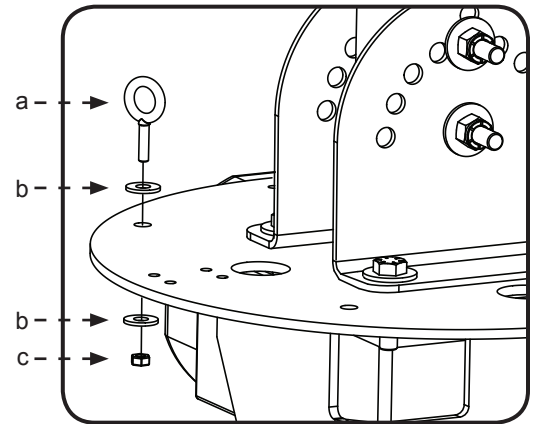

## 2. Attach beam clamp

**CAUTION:** When taut, the guy wire must be clear of moving fan airfoils. Place the beam clamp accordingly.

Attach the beam clamp to an I-beam, bar joist, or other approved mounting structure.

Fasten the small eyebolt and nut onto the beam clamp. The nut will be on the outside of the beam clamp.

Loop the crimped end of the guy wire into the locking carabiner and secure to the eyebolt as shown. Securely tighten the carabiner.

### Guy Wire Hardware (BAF-Supplied):

- a. 1/4" Beam Clamp
- b. 1/4-20 x 1" Eyebolt
- c. 1/4-20 Hex Nut
- d. Locking Carabiner
- e. Guy Wire

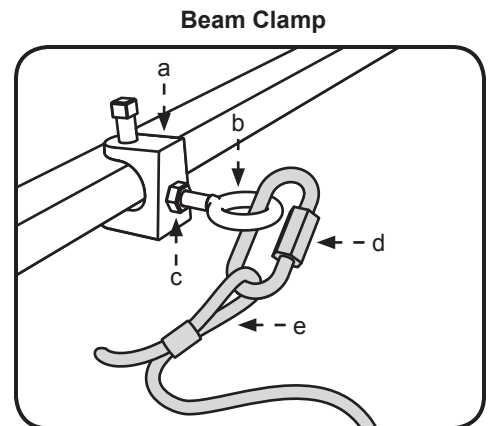

## 3. Route guy wire through Gripple®

Route the guy wire through the Gripple, the eyebolt on the motor frame, and then back through the Gripple as shown. Do not tighten the Gripple until the remaining guy wires have been installed.

*Note: To back the guy wire out of the Gripple, insert 1/16 (1.5 mm) Allen wrench into the small hole on the Gripple.*

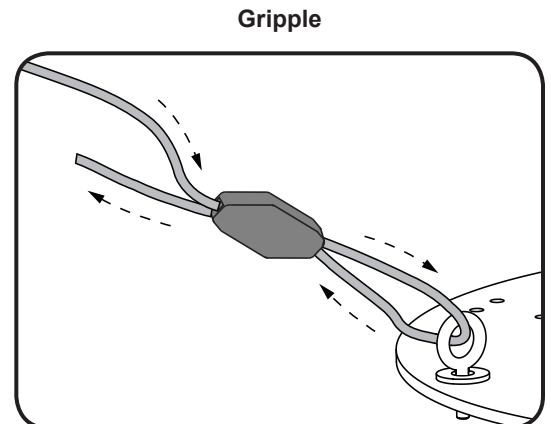

#### 4. Install remaining guy wires

- ⚠ **CAUTION:** Over-tightening the guy wires could throw the fan off balance.
- ⚠ **CAUTION:** The guy wires should be spaced evenly around the fan and clear of the airfoils.

Repeat steps 1–3 to install the three (3) remaining guy wires.

Evenly cinch all four guy wires into place using the Gripples®. Route the guy wires so they do not cross into the airfoils or into the cage. The guy wires should be taut.

Once all of the guy wires are taut, secure their loose ends with the wire rope clips as shown.

Wire Rope Clip

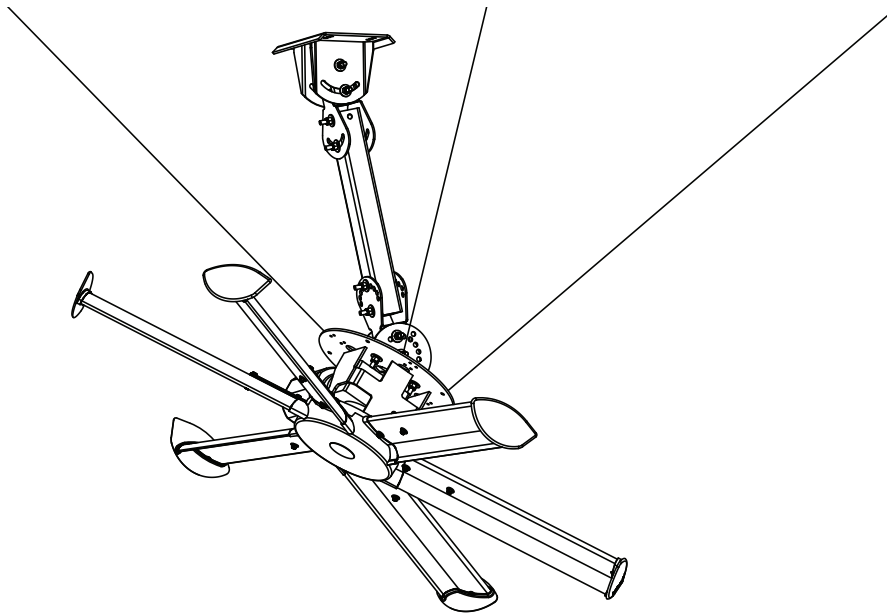
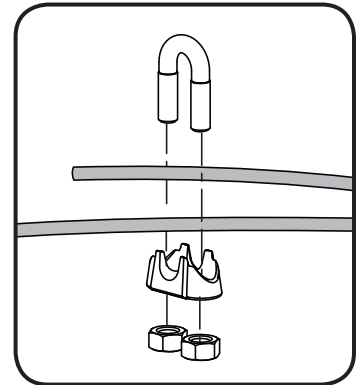

## Electrical Installation

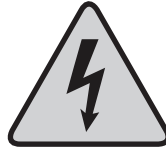

**WARNING:** To reduce the risk of electric shock, wiring should be performed by a qualified electrician! Incorrect assembly can cause electric shock or damage the motor and the controller! Hazard of electrical shock!

**WARNING:** The installation of a Big Ass Fan must be in accordance with the requirements specified in this installation manual and with any additional requirements set forth by the National Electric Code (NEC), ANSI/NFPA 70-2011, and all local codes. Code compliance is ultimately YOUR responsibility!

**WARNING:** The fan controllers contain high voltage capacitors that take time to discharge after removal of mains supply. Before working on the fan controller, ensure isolation of mains supply from line inputs at the fan controller's disconnect if installed (L1, L2/N, and L3). Wait three (3) minutes for capacitors to discharge to safe voltage levels. Failure to do so may result in personal injury or death. Note: Darkened display LEDs are not an indication of safe voltage levels.

**CAUTION:** It is the sole responsibility of the installer to verify the operating voltage of the fan system prior to installation! It is also mandatory that the installer verify that airfoils, motor hub assemblies, and fan controllers are matched properly at the time of installation, especially if multiple fan systems will be installed.

**CAUTION:** An incorrectly installed controller can result in component damage or reduction in the fan's life. Wiring or application errors such as under-sizing the controller, incorrect or inadequate AC supply, or excessive ambient temperatures may result in a malfunction of the fan system. Verify correct voltage, phase, and horsepower before beginning installation!

**WARNING:** Exercise caution and common sense when powering the fan. Do not connect the fan to a damaged or hazardous power source. Do not attempt to resolve electrical malfunctions or failures on your own. Contact Big Ass Fans if you have any questions regarding the electrical installation of this fan.

**CAUTION:** For use with Big Ass Fans-supplied variable frequency drive only. Not for use with other speed control devices!

**CAUTION:** Shielded cable, if applicable, must be landed on the motor's ground terminal!

**CAUTION:** To avoid a short circuit, be very careful not to get metal chips in the controller!

**CAUTION:** The Big Ass Fans product warranty will not cover equipment damage or failure that is caused by improper installation.

**CAUTION:** The following information is merely a guide for proper installation. The Big Ass Fans Company cannot assume responsibility for the compliance or the non-compliance to any code, national, local, or otherwise for the proper installation of these fan controllers, fans, or associated equipment. A hazard of personal injury and/or equipment damage exists if codes are ignored during installation

### Electrical installation overview

---

The electrical installation section is intended for a professional electrician. If you are unfamiliar or uncomfortable with installing electrical components, do not attempt to install the fan without an electrician. Serious personal injury or damage to the fan and other equipment could result. This guide is merely a recommendation of proper installation. Adhering to national and local electric codes is your responsibility. It is the sole responsibility of the installer to verify the operating voltage of the fan system prior to installation! It is also mandatory that the installer verify that airfoils, motor assemblies, and fan controllers are matched properly at the time of installation, especially if multiple fan systems will be installed.

The following sections outline how to prepare for the electrical installation, and include the required cables and how to properly route the cabling through conduit, how to properly ground the fan system, how to properly wire the fan controller, how to properly wire the fan motor, and proper startup procedures.

### Controller storage

---

Store the controller within an ambient temperature range of -40°F to 185°F (-40°C to 85°C) and a relative humidity range of 0 to 95%, non-condensing. Do not expose the controller to a corrosive atmosphere. If the controller has been in storage or disconnected from power for more than one year, apply AC supply power to the controller for a period of two hours prior to operation in order to recondition the internal DC bus capacitors.

## Power requirements for fan controllers

The power requirements for Big Ass Fans controllers are shown in the specification table in the introduction. If multiple controls are connected to one feeder circuit, the circuit required is the sum of the feeder circuit requirements listed on the chart. For example, if two 240V 3Φ controllers are connected to a single feeder circuit, that circuit needs to be rated for 20 amps. This type of installation will also require that each fan control be installed downstream from a dedicated over-current protection device.

## Mounting the wall controller

Mount the controller to a wall using a #8–#10 screw. Adhere to the following guidelines when selecting the controller location:

- Install the controller on a flat surface that is readily accessible, free from vibration, and where there is adequate distance from foreign objects or moving equipment.
- Do not mount any controller adjacent to or above a heat source or heat-producing equipment.
- The ambient temperature must be between 14° F (-10° C) and 122° F (50° C).
- Do not expose the controller to a corrosive atmosphere or direct sunlight.
- When mounting the controller, keep in mind that the fan should be visible from the controller.
- A minimum distance of 6" (15.2 cm) should be maintained between fan controllers.

*Note: Multiple fan controllers are available as a special order only. Please contact Customer Service for more information.*

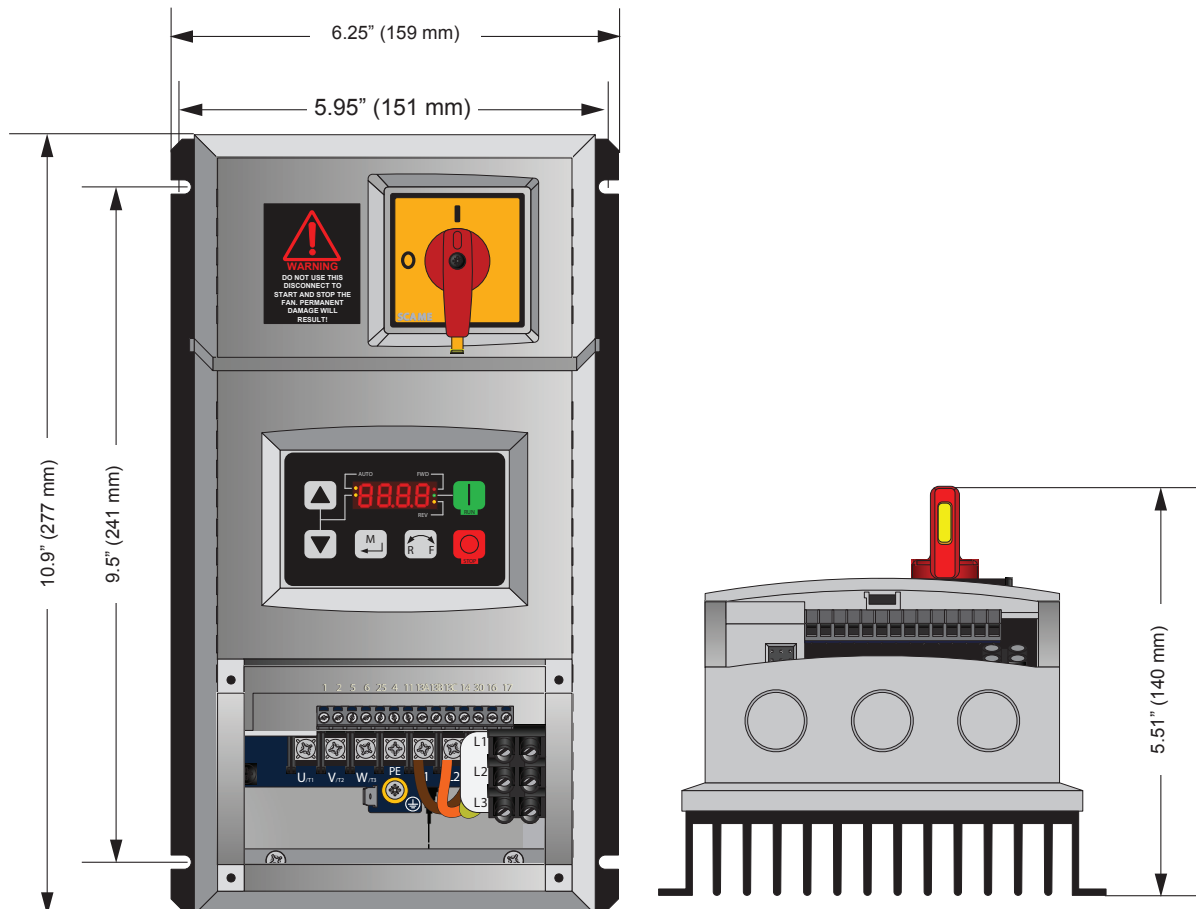

## 26

## Electrical Installation (cont.)

## Input power conditioning

---

Line reactors should be installed if AC supply is subject to any of the following:

- Low line impedance
- Frequent power interruptions
- Phase-to-ground voltage in excess of 125% nominal phase-to-phase voltage
- Distribution system exceeds established kVA limit for your specific model (contact Big Ass Fans for more information).
- Power factor correction capacitors
- Intermittent noise spikes (lightning)

## Conduit and piping guidelines

---

- ⚠ CAUTION: The presence of foreign signals on a drive's output wiring greatly reduces the controller's ability to control current and speed regulation of the fan. Any wiring practice that would allow this kind of "cross-talk" must be avoided. Failure to do so may result in nuisance tripping and/or premature equipment failure. Sources of foreign signals that could induce such signals include another VFD's output circuit, long "across-the-line" motor circuits, and lighting circuits.**
- ⚠ CAUTION: Recommendations for fan controller output/motor lead routing deem some conventional wiring practices "unacceptable." National and/or local code does not differentiate between solid-state and electromechanical systems; however, due to the nature of the Big Ass Fan system, there are additional requirements that must be met to ensure proper operation.**

The nature of Variable Frequency Drive systems (VFD) must be considered prior to and during the installation of Big Ass Fans. Due to high frequency electrical noise on the output side of the fan controller, measures must be taken to ensure that wires and cabling are routed in a manner consistent with recommendations made in this section. Big Ass Fans controllers rely on "motor feedback" through the cabling to sense motor speed, slip, etc.

### Controller AC supply

Most conventional methods of power distribution and branch circuit installation apply to all models of fan controllers. Installation must comply with specifications regarding wire types, conductor sizes, branch circuit protection, and disconnecting devices. Failure to do so may result in personal injury and/or equipment damage. Refer to p. 25 for specific ampacities.

- AC supply feeds for one fan controller can share the same conduit with AC supply feeds for one or more additional controllers.
- AC supply feeds for a fan controller and output/motor leads for the same fan controller cannot share a conduit.
- AC supply feeds for one fan controller cannot share conduit with output/motor leads from one or more additional controllers/VFDs.
- Any unused conductors that share a conduit with an AC supply feed should be grounded on both ends to prevent risk of electric shock due to induced voltages.
- Output/motor leads for a fan controller and AC supply feeds for the same fan controller cannot share a conduit.
- Output/motor leads for one fan controller cannot share conduit with AC supply feeds or output/motor leads from one or more additional fan controllers.
- Any unused conductors that share a conduit with fan controller output/motor leads should be grounded on both ends to prevent risk of electric shock due to induced voltages.

## Power wiring guidelines

---

**In order to satisfy some code requirements, it may be necessary to install a manual disconnect at the fan motor location when the fan assembly is not within "line-of-sight" from the fan controller. A non-fused, 600V 3-phase, blade style disconnect should be used to satisfy this "line-of-sight" requirement.**

- ⚠ WARNING: Installation must comply with specifications from National Electrical Codes and standards (NEC, VDE, BSI, etc.) regarding wire types, conductor sizes, branch circuit protection, and disconnecting devices.**
- ⚠ WARNING: To avoid a possible shock hazard and/or nuisance tripping caused by induced voltages, unused wires in the conduit must be grounded at both ends. For the same reason, fan controller output wires should not share a conduit with another fan controllers output leads, or other power circuits (lighting, motors, etc.).**
- ⚠ CAUTION: MC or "Metal clad" cable cannot be used for controller output/motor leads. Both stranded and solid core varieties must be avoided. Do not use solid core cable of any size or insulation class for motor wiring. Use of such types of cabling may result in nuisance tripping or premature equipment failure.**

A variety of cable types are acceptable for variable frequency drive installations. *For many installations, unshielded cable is adequate if it can be separated from sensitive circuits.* In all cases, parallel runs of control and motor cabling should be avoided when unshielded cable is used. Do not use cable with an insulation thickness of less than 15 mils.

- UL installations in 50°C ambient must use 600V, 75°C or 90°C wire.
- UL installations in 40°C ambient should use 600V, 75°C or 90°C wire.

## Power wiring guidelines (cont.)

### Acceptable unshielded types

THHN, THNW, or similar wire is acceptable for drive installations in dry environments if adequate free air space and/or conduit fill rate limits are provided. *Do not use THHN or similarly coated wire in wet areas.* Any wire chosen must have a minimum insulation thickness of 15 mils and should not have large variations in insulation concentricity.

### Acceptable shielded types

The drain conductor included with shielded cables must be connected to both the motor frame and the PE/Ground terminal of the Variable Frequency Drive.

Location	Rating / Type	Description
Standard (Option 1)	600V, 75°C or 90°C (167°F or 194°F) RHH/RHW-2	<ul style="list-style-type: none"> <li>Four tinned conductors with XLPE insulation</li> <li>Foil shield and tinned copper drain wire with 85% braid coverage</li> <li>PVC Jacket</li> </ul>
	Belden 29501-29507 or equivalent	
Standard (Option 2)	Tray rated 600V, 75°C or 90°C (167°F or 194°F) RHH/RHW-2	<ul style="list-style-type: none"> <li>Three tinned copper conductors with XLPE insulation</li> <li>5 mil single helical copper tape (25% overlap minimum) with three bare copper grounds in contact with shield</li> <li>PVC Jacket</li> </ul>
	Shawflex 2ACD/3ACD or equivalent	
Class I & II Division I & II	Tray rated 600V, 75°C or 90°C (167°F or 194°F) RHH/RHW-2	<ul style="list-style-type: none"> <li>Three bare copper conductors with XLPE insulation with impervious corrugated continuously welded aluminum armor</li> <li>Black sunlight resistant PVC jacket overall</li> <li>Three copper grounds on #10 AWG and smaller</li> </ul>

### Maximum cable lengths

To prevent nuisance trips, the distance between the controller and the fan should not exceed 400 ft (122 m).

### Output disconnects

A device, such as a contactor, that routinely disconnects and reapplies output power to the motor for the purpose of starting and stopping the motor cannot be used.

### Recommended wire size

A minimum of 14AWG is acceptable for motor leads. *14AWG applies to motor leads only.* Power feeders to controllers must be governed by the fuse size included with the fan controller and/or required circuit breaker.

## Grounding

The nature of Variable Frequency Drive systems must be considered prior to and during the installation of Big Ass Fans. Due to high frequency content on the output side of the fan controller, measures must be taken to ensure that all grounding connections conform to the recommendations made in this section.

The fan controller's safety ground  (PE) must be connected to system ground. Ground impedance must conform to the requirements of national and local industrial safety regulations and/or electrical codes. The integrity of all ground connections should be periodically checked. All ground leads for downstream conduit boxes must be kept separate from the motor ground and terminated on the fan controller's PE terminal.

### Motor ground

The motor ground must be connected to a ground terminal on the VFD to aid in keeping high frequency electrical noise off of the building's ground grid.

### Shielded motor cable terminations

Either of the safety ground terminals on the drive provides a grounding point for the motor cable shield. The motor cable shield connected to one of the drive terminals must also be connected to the motor frame. If no drain lead is present, the cable must be stripped back so that the braid can be twisted and soldered to a pigtail for proper termination.

## Installing the Electronic Programming Module (EPM)

**If hanging multiple fans, ensure to install the exact EPM included in each fan's packaging. EPMs are not interchangeable!**

**⚠ CAUTION: Install the EPM prior to applying power to the fan controller!**

The Electronic Programming Module (EPM) contains all programming information specific to fan operation. It *must* be installed prior to applying power to the fan controller. This module is provided as part of the fan's accessory kit.

**To install the EPM**, disconnect the fan from power (refer to the position of the disconnect switch below). Insert the EPM in the location shown below. *Note: The EPM can only be inserted one way. Do not force it!*



## Wiring: Early Suppression Fast Response (ESFR)

- ⚠ **WARNING:** Wait three minutes after disconnecting before servicing!
- ⚠ **WARNING:** Improper installation can cause electric shock or damage to the motor and controller. A qualified electrician should perform the installation.

**ATTENTION:** If installing the fan in the United States, the fan must be installed per the following National Fire Protection Association (NFPA) guidelines:

- The fan must be centered approximately between four adjacent sprinklers.
- The vertical distance from the fan to the sprinkler deflector must be at least 3 ft (91.4 cm).
- The fan must be interlocked to shut down immediately upon receiving a waterflow signal from the alarm system.

The fire relay included with the fan is needed only if the fan will be installed in a building that has a fire sprinkler system. The fire relay integrates the fan with the sprinkler system and shuts down the fan upon receiving an alarm signal from the system. If the building in which the fan will be installed has a sprinkler system, you must install the relay according to the instructions below.

A contact closure across the digital input terminals 4 and 13A will result in fan shutdown. The included relay uses a Normally Open (N.O.) contact as shown below. The relay coil must be energized by the FACP for fan shutdown. Optionally, the normally closed (N.C.) relay contact can be used. The relay coil must remain energized by the FACP for fan operation. This would be considered a fail safe or fail open wiring arrangement. Two additional relay coil leads are provided to facilitate supervision pass-through where required.

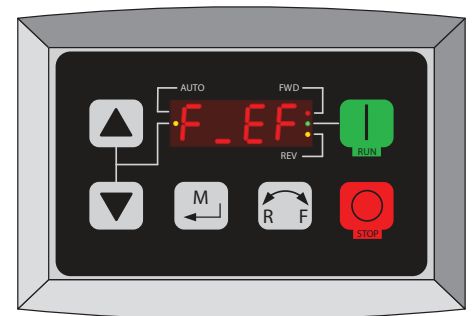
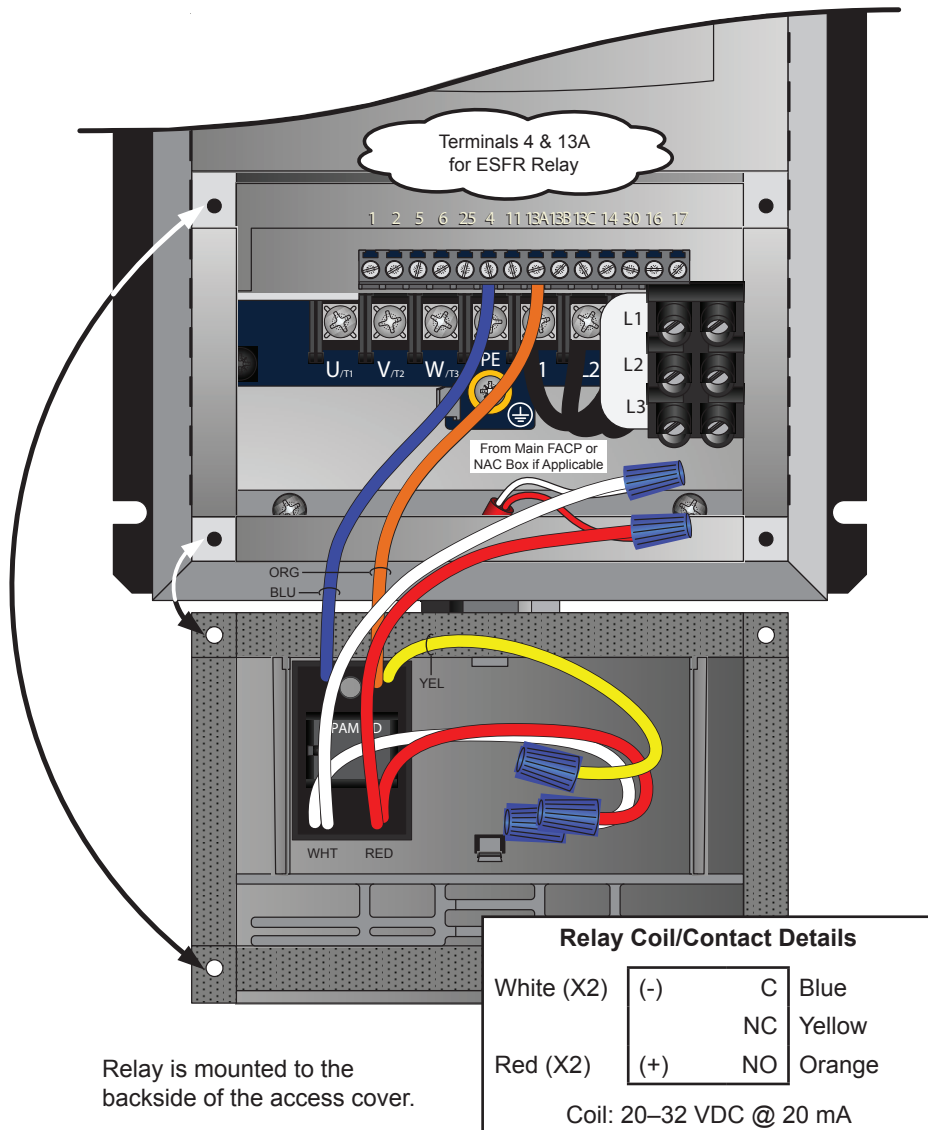

An alarm condition will stop the fan and issue an "F\_EF" external fault on the controller's display.

**Wiring: 100–125V/200–250V single-phase fan controllers**

- ⚠ **WARNING:** Wait three minutes after disconnecting before servicing!
- ⚠ **WARNING:** Improper installation can cause electric shock or damage to the motor and controller. A qualified electrician should perform the installation.

The diagrams below shows wiring option for a 100–125V/200–250V 1Φ fan controller. See “Power Requirements for Fan Controllers” on page 25 for detailed power requirements.

**Wiring for 200–250V 1Φ, 50/60Hz fan controllers**

The neutral terminal is not used when wiring the fan controller for 200–250V 1Φ. A disconnect and EMI filter are included with this fan controller.

*Note: This fan controller does not contain fusing!  
Power must be supplied to this controller via a dedicated circuit breaker or properly fused disconnect!*

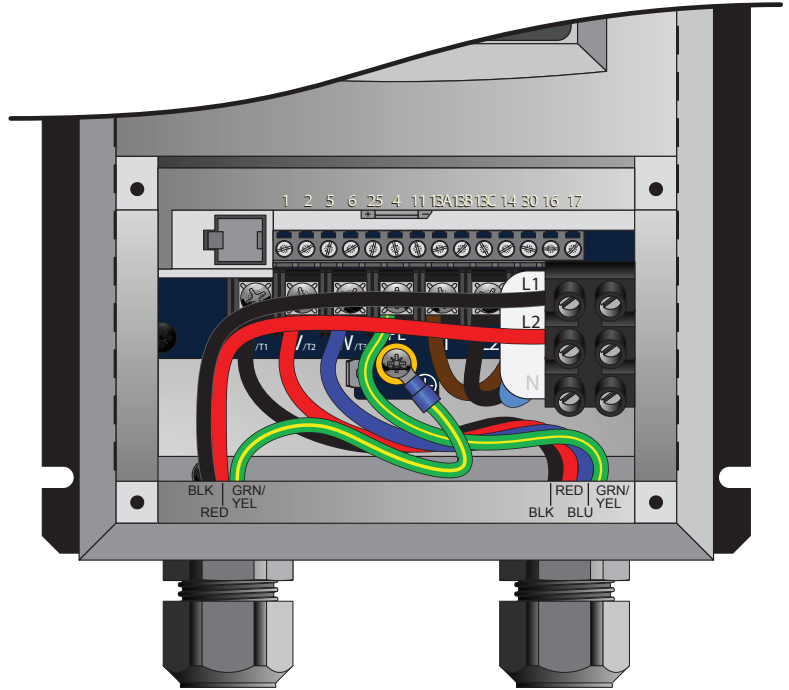

**AC Input Wiring  
2W plus GND**

**Motor Output Wiring  
3W plus GND**

**Optional wiring for 100–125V 1Φ, 50/60Hz fan controllers**

The L2 terminal is not used when wiring the fan controller for 100–125V 1Φ. A disconnect is included with this fan controller.

*Note: This fan controller does not contain fusing!  
Power must be supplied to this controller via a dedicated circuit breaker or properly fused disconnect!*

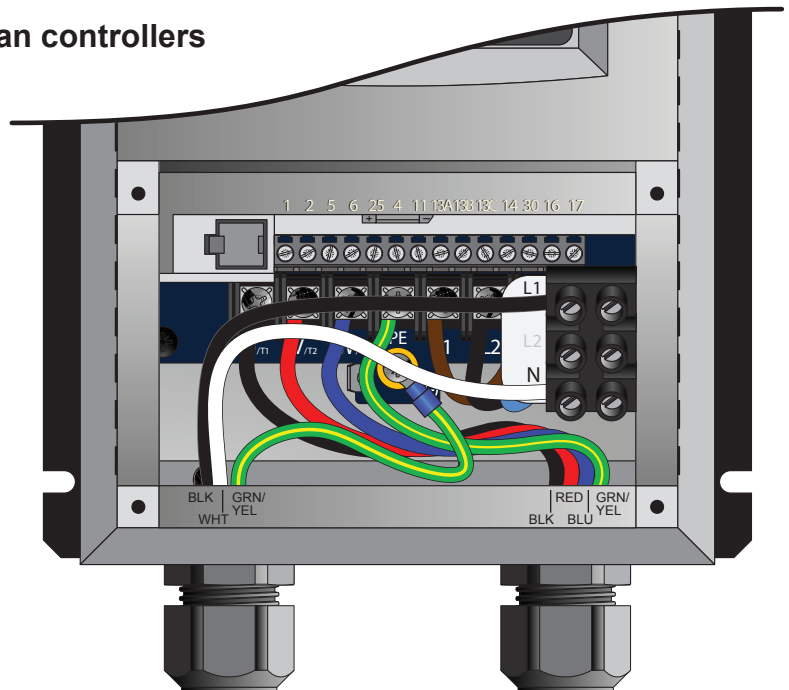

**AC Input Wiring  
2W plus GND**

**Motor Output Wiring  
3W plus GND**

## Wiring: 200–250V three-phase fan controllers

- ⚠ **WARNING:** Wait three minutes after disconnecting before servicing!
- ⚠ **WARNING:** Improper installation can cause electric shock or damage to the motor and controller. A qualified electrician should perform the installation.

The diagrams below show wiring options for a 200–250V 3 $\Phi$  fan controller. See “Power Requirements for Fan Controllers” on page 25 for detailed power requirements.

### Wiring for 200–250V 3 $\Phi$ , 50/60Hz fan controllers

A disconnect is included with the fan controller for 200–250V 3 $\Phi$ . An EMI filter is not included with this fan controller.

*Note: This fan controller does not contain fusing!  
Power must be supplied to this controller via a dedicated circuit breaker or properly fused disconnect!*

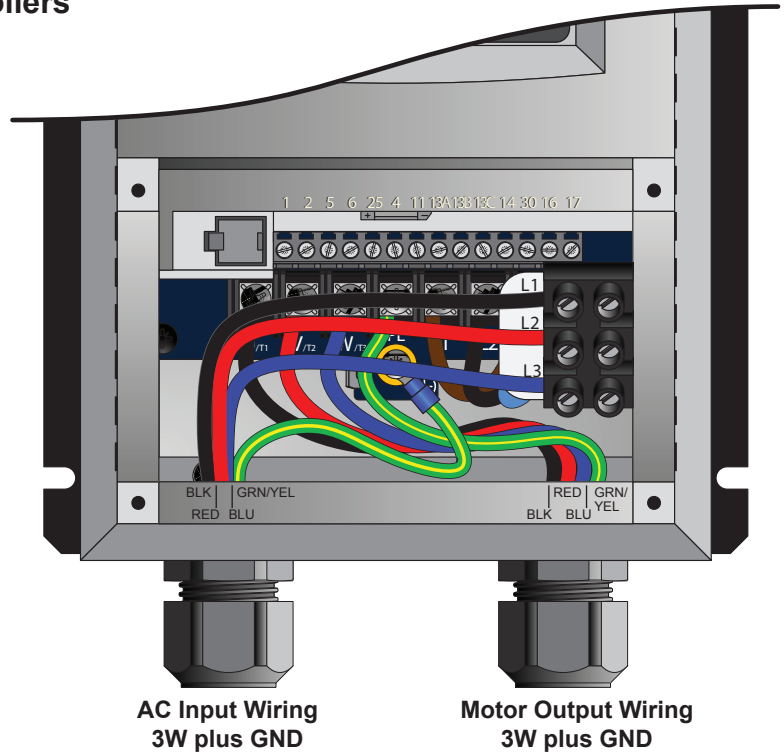

### Optional 1 $\Phi$ wiring for 200–250V 3 $\Phi$ , 50/60Hz controllers

The L3 terminal is not used when wiring the fan controller for 200–250V 1 $\Phi$ . A disconnect is included with the fan controller. An EMI filter is not included with this fan controller.

*Note: This fan controller does not contain fusing!  
Power must be supplied to this controller via a dedicated circuit breaker or properly fused disconnect!*

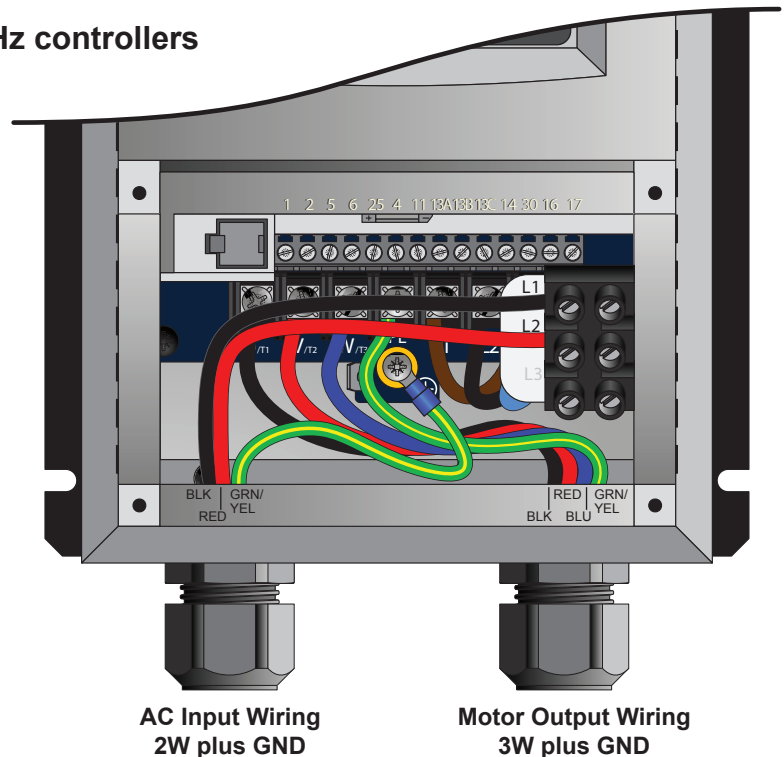

## Wiring: 400–480V & 575–600V three-phase fan controllers

- ⚠ **WARNING:** Wait three minutes after disconnecting before servicing!
- ⚠ **WARNING:** Improper installation can cause electric shock or damage to the motor and controller. A qualified electrician should perform the installation.

The diagram below shows wiring options for 400–480V 3 $\Phi$  and 575–600V 3 $\Phi$  fan controllers. See “Power Requirements for Fan Controllers” on page 25 for detailed power requirements.

### Wiring for 400–480V 3 $\Phi$ , 50/60Hz fan controllers

An EMI filter and disconnect are included with the fan controller for 400–480V 3 $\Phi$ .

*Note: This fan controller does not contain fusing!  
Power must be supplied to this controller via a dedicated circuit breaker or properly fused disconnect!*

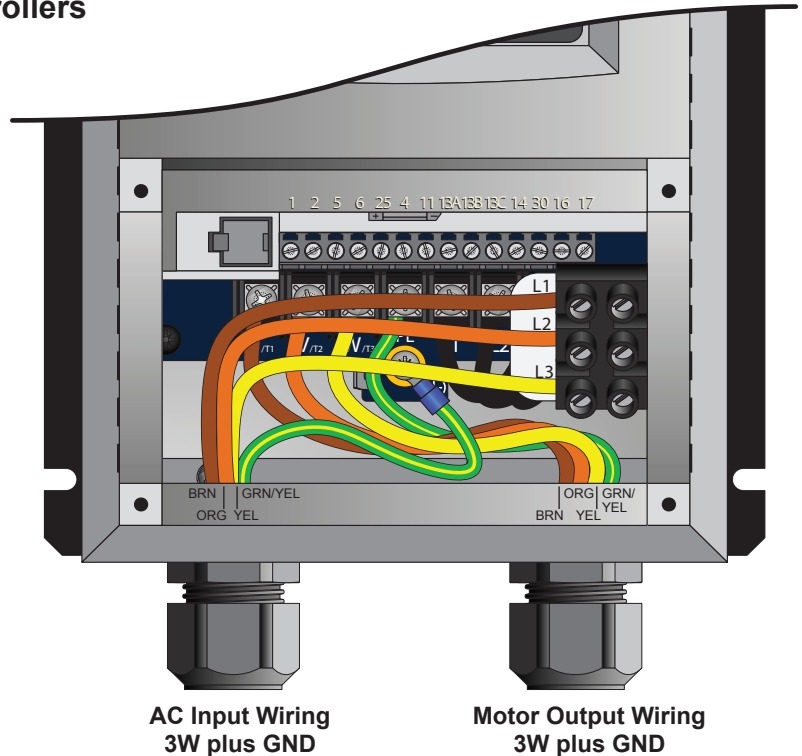

### Wiring for 575–600V 3 $\Phi$ , 50/60Hz controllers

A disconnect is included with the fan controller for 575–600V 3 $\Phi$ . An EMI filter is not included with this fan controller.

*Note: This fan controller does not contain fusing!  
Power must be supplied to this controller via a dedicated circuit breaker or properly fused disconnect!*

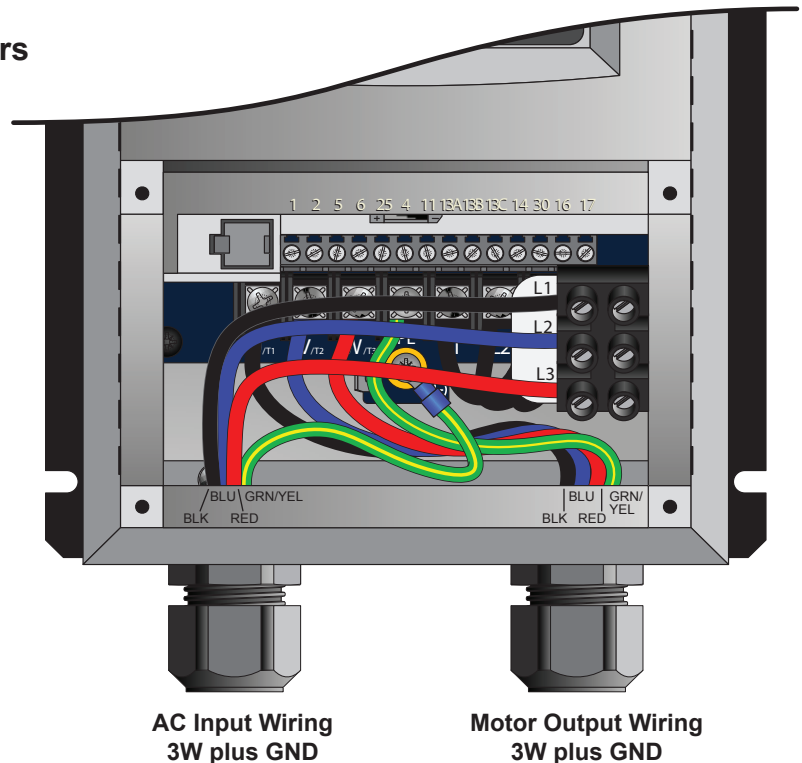

## Daisy Chaining

**⚠ WARNING: Wait three minutes after disconnecting before servicing!**

The following illustrations and parameter changes enable daisy chaining of the Pivot fan speed controller. The first fan provides a start/stop contact and 0–10VDC analog speed reference for the downstream fan controller. The downstream fan controller provides a new start/stop contact and 0–10VDC analog speed reference for the following downstream fan controller. This preferred method of linking the fan controllers together ensures minimal signal loss of command signals in larger multi-fan systems.

### Assertion Level Switch (ALSW)

The fan controller ships with the onboard digital I/O configured for Sourcing (PNP) operation. Terminal 4 provides +15VDC to be used as a supply voltage for user-supplied switches and accessories. For this 3-wire daisy chaining application, the downstream fan controllers must be switched to Sinking (NPN) operation. Terminal 4 will then provide a DC common connection and allow the analog signal and start stop signal to share that common. **The Assertion Level Switch above terminal 4 must be switched from (+) to (-) on all downstream fan controllers for proper daisy chaining operation prior to powerup, parameter changes and operation.**

### Parameter changes (for first controller)

Parameter	Description
<b>P140</b>	<b>Relay Output Function</b> Change from "0" for None to "1" for Run.
<b>P150</b>	<b>TB-30 Output</b> Change from "0" for None to "1" for 0–10VDC output (scaled to drive output frequency).
<b>P152</b>	<b>TB-30 Scaling Frequency</b> Change to equal the frequency setting of P103 Maximum Frequency.
<b>P161</b>	<b>Speed at Max Signal</b> Change to equal the frequency setting of P103 Maximum Frequency.

### Parameter changes (for downstream controllers)

Parameter	Description
<b>P120</b>	<b>Assertion Level</b> Change from "2" for High to "1" for Low.
<b>P100</b>	<b>Start Control Source</b> Change from "0" for keypad operation to "1" for Terminal Strip.
<b>P101</b>	<b>Standard Reference Source</b> Change from "0" for keypad operation to "1" for 0–10VDC analog input operation.

*Note: Depending on the AWG and distance of the low voltage wiring, the downstream fans may run slightly slower than the leading fan. If this occurs, P161 Speed at Max Signal can be used to introduce a minor command reference overshoot to compensate for the analog voltage drop. At each downstream fan (beginning with the first downstream fan), adjust the value of P161 up 0.1 to 0.2Hz increments until the fan's output frequency matches that of the lead fan.*

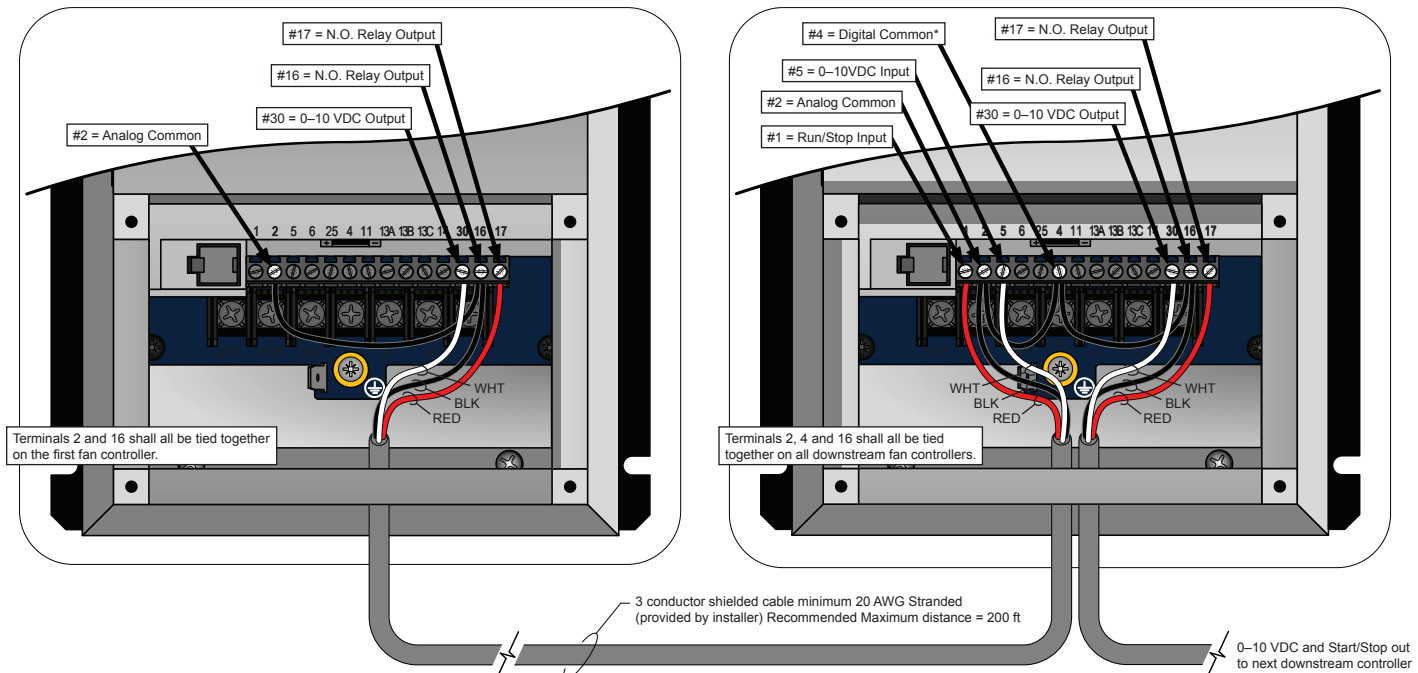

**Wiring the fan motor: 9 lead, dual voltage, wye motor configurations**

The motor wiring configurations shown below are applicable to 9 lead dual voltage wye wound motors rated for 230/460VAC and 330/600VAC. Consult the motor nameplate and/or wiring placard for verification of required wiring connections. Motors with terminal blocks require ring terminals and a 7 mm nut driver for termination. The diagrams below include L2 and L3 swap to yield proper motor rotation. *Note: Swapping leads to reverse rotation is done only on the output side of the drive.*

**Low Voltage**  
200–240VAC, 50–60Hz  
330–350VAC, 50–60Hz

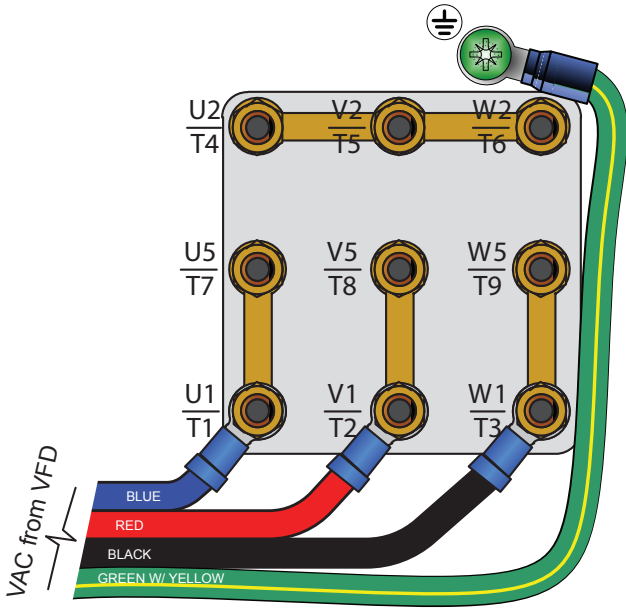

**High Voltage**  
400–480VAC, 50–60Hz  
575–600VAC, 50–60Hz

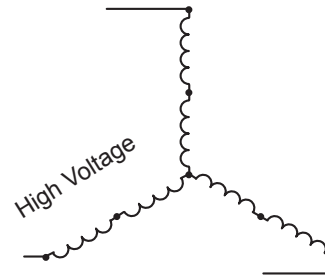
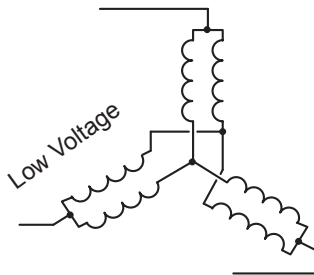
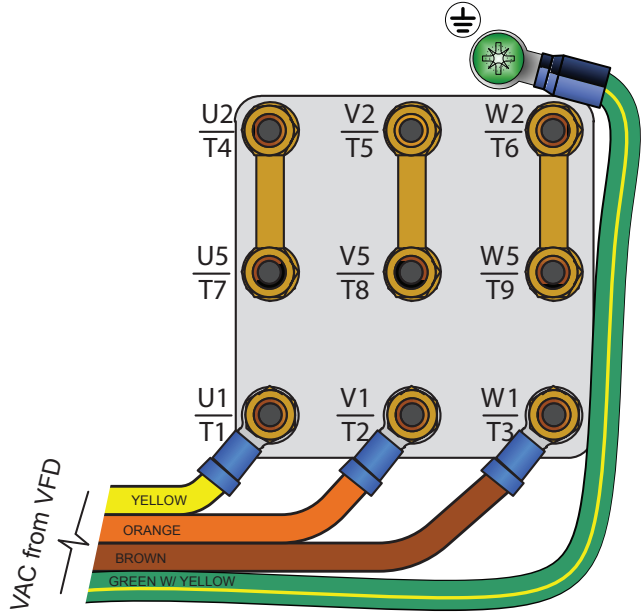

Jumper bars are provided with the motor

## Operating the fan controller

**⚠ WARNING:** The following startup procedures apply to standard model controllers. Procedures may vary depending on installation options and system automation. The installer should verify proper wiring, terminations, and proper voltage supply before proceeding. High voltage gloves and arc flash protection are recommended.



**Drive Idle/Stopped Screen**



### Starting and stopping the fan

The RUN and STOP buttons control the fan start and stop functions. **To start the fan**, press the green RUN button. **To stop the fan**, press the red STOP button.



### Adjusting fan speed

The Arrow buttons control speed adjustment. **To adjust fan speed**, press the Up or Down Arrow button. Single presses will increase or decrease the speed in 1-2% increments. Pressing and holding the Up or Down Arrow button will slowly and continuously adjust fan speed until the button is released.



**Fan Speed Percentage Display**  
(73.5% Running FWD)

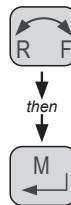

### Reversing direction of fan rotation

The direction of fan rotation can be reversed when the fan is stopped or running. To reverse the direction of rotation, press the Direction button, and then press the Memory/Enter button (as shown on the left). The associated Direction indicator will flash, indicating the pending change.

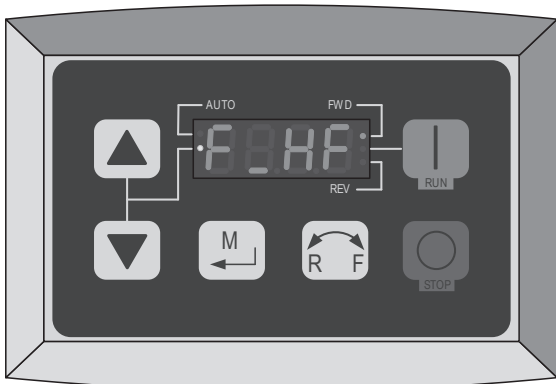

**Typical Fault Message Display**  
(Incoming Line Over-Voltage Shown)

*Note: The fan should rotate in same direction (counterclockwise when viewed from the floor) during both the warmer and cooler months. If the fan is not rotating in this direction, press the Direction button, and then press the Memory/Enter button. During the warmer months, run the fan at higher speeds. This will circulate the air and provide a cooling breeze. During the cooler months, run the fan at lower speeds. This will push warmer air down from the ceiling to the floor without creating a cooling breeze.*

# 36

# Preventive Maintenance

Please take a few moments each year to perform the following preventive maintenance inspection on your fan to ensure its safe and efficient operation. If you have any questions, please contact Customer Service.

- ⚠ **WARNING: Risk of fire, electric shock, or injury to persons during cleaning and user-maintenance! Disconnect the appliance from the power supply before servicing.**
- ⚠ **WARNING: Before servicing or cleaning the fan, switch off power at service panel and lock the service disconnecting means to prevent power from being switched on accidentally. When the service disconnecting means cannot be locked, securely fasten a prominent warning device (such as a tag) to the service panel.**
- ⚠ **WARNING: When service or replacement of a component in the fan requires the removal or disconnection of a safety device, the safety device is to be reinstalled or remounted as previously installed.**

## Annual preventive maintenance

*Note: Actual installation setup may differ from picture.*

To be performed annually (see "Maintenance Checklist"):

1. Ensure safety cable is present and securely tightened. The cable should be tightly wrapped around the mounting structure with as little slack as possible. The shackle should be located on the topside of the mounting structure. The shackle's screw pin should be securely tightened.
2. Ensure all mounting bolts (16x or 12x depending on installation setup) are present and torqued to 40 ft·lb (54.2 N·m).
3. Inspect motor terminations inside junction box and tighten if necessary.
4. Check gear reducer for oil leakage. If leakage is present, contact Customer Service.
5. Ensure all airfoils are secured to one another by airfoil retainers.
6. Ensure all bolts (18x) securing airfoils to fan are present and torqued to 29 ft·lb (47 N·m).
7. Ensure all screws (10x) securing winglets to airfoils are securely tightened.
8. Check guy wires (if installed) for fraying or damage.

## General preventive maintenance

- Dust airfoils, motor, and motor housing. If desired, use a gentle cleaner or degreasing agent to polish the airfoils. Do not use Clorox® or other chlorine based cleaners! This could result in the release of toxic/fatal fumes.
- Check all fan controller connections and tighten as needed. Using a vacuum, remove all dust and debris from the inside and outside of the controller.
- Verify proper fan rotation. To be effective, the fan must be turning counterclockwise when viewed from the floor. To change the direction of the fan's rotation, see instructions on page 36.

- ⚠ **WARNING: Do not operate a fan with missing or damaged components! Please contact Customer Service.**

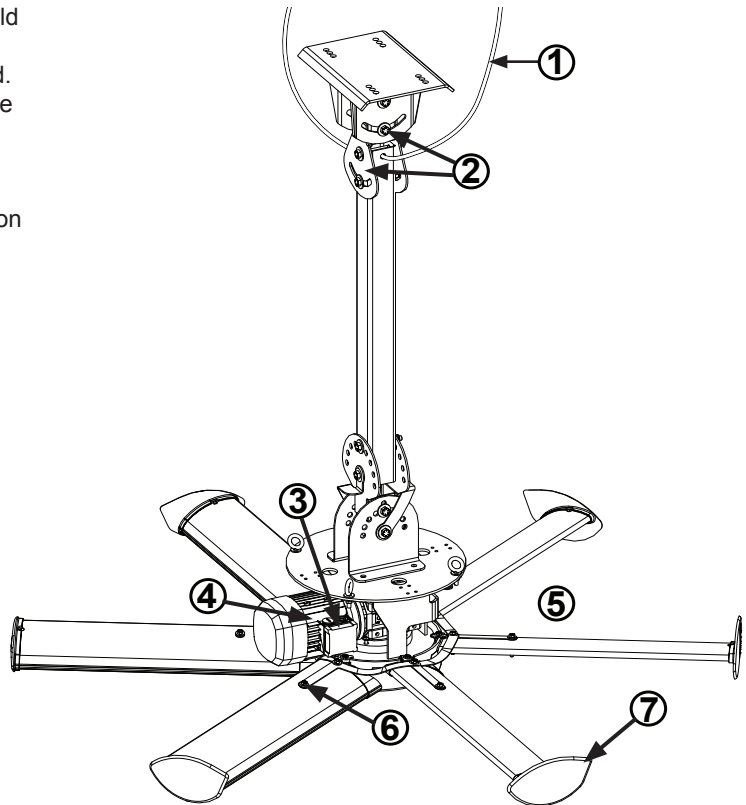





# Troubleshooting

- ⚠ **WARNING:** When servicing or replacement of a component in the fan requires the removal or disconnection of a safety device, the safety device is to be reinstalled or remounted as previously installed.
- ⚠ **WARNING:** Risk of fire, electric shock, or injury to persons during cleaning and user-maintenance. Disconnect fan from power supply before servicing.
- ⚠ **WARNING:** TO REDUCE THE RISK OF FIRE, ELECTRIC SHOCK, OR INJURY TO PERSONS, OBSERVE THE FOLLOWING:
- Use this fan only in the manner intended by the manufacturer. If you have questions, contact the manufacturer.
  - Before servicing or cleaning the fan, switch power off at service panel and lock the service disconnecting means to prevent power from being switched on accidentally. When the service disconnecting means cannot be locked, securely fasten a prominent warning device, such as a tag, to the service panel.

Customers in the United States	Customers outside of the United States
For questions about your product or customer service inquiries, please call our toll free number (877-BIG-FANS) or visit <a href="http://www.bigassfans.com/service">www.bigassfans.com/service</a> .	For questions about your product or customer service inquiries, please contact your local Big Ass Fans representative or fill out a contact form at <a href="http://www.bigassfans.com/service">www.bigassfans.com/service</a> .

Some issues can be resolved before requesting service. Review the below troubleshooting tips before contacting Customer Service for support.

Symptom	Possible solution(s)
<i>The fan is turning in the wrong direction.</i>	To be effective, the fan should be rotating in the counterclockwise direction when viewed from the floor. If the fan is not rotating in the counterclockwise direction, press the F/R button on the controller.
<i>A popping noise is coming from the fan.</i> Airfoil noise comes from airfoils that are not tightened to the specified torque.	Disconnect the fan from power, and then tighten the airfoil fasteners to 29 ft·lb (39.3 N·m). If the popping still occurs, verify that the airfoils are not contacting each other. If they are, contact Big Ass Fans Customer Service.
<i>The fan will not start.</i>	Verify the following: <ul style="list-style-type: none"> <li>Make sure that all wires are securely connected.</li> <li>Verify that supply power is adequate and functional.</li> </ul> <p>If the fan still does not start, contact Customer Service.</p>
<i>The fan controller generates radio frequency noise (RF).</i> Fan controllers generate RF noise in many ways, but this can be prevented using the proper wiring practices outlined in "Electrical Installation" (p. 24).	Verify the following: <ul style="list-style-type: none"> <li>Do not run your controller and sensitive equipment on the same power line.</li> <li>Install shielded cables, run leads in grounded metallic conduit, or use appropriate size 4 conductor shielded cable for motor leads.</li> <li>Ensure proper grounding at the motor, controller, and from the controller to the utility.</li> </ul> <p>If the noise is still present, contact Customer Service.</p>
<i>The motor makes noise when fan speed is increased.</i> Audible high frequency carrier noise may be an indicator of a stall condition.	Verify motor currents are within limits. See the fan specifications on page 1.

*Note: Some motor, gearbox, or drive noise is to be expected and is normal.*

# 40

# Warranty Return Instructions

Congratulations on your purchase of a Big Ass Fan! We are delighted that you have chosen our product to improve the quality of your indoor environment, and hope you'll have much pleasure using the fan for years to come.

## **Replacement of products under warranty acknowledgment & return instructions**

---

We have received your request for replacement of a part that failed during normal use and that you believe to be covered under warranty. We are shipping this replacement part to you pursuant to your notice that you will be replacing the original part within 10 days.

This replacement part is being shipped to you prior to our receipt of the item that failed, and prior to our evaluation of this part to determine the reasons for its failure and whether it is covered under warranty.

In order to evaluate the cause of the product failure, we need you to return the original part to our offices within 10 working days of receipt of the replacement part. Should the part be covered under warranty, you will not be charged for the replacement item. However, you will be charged for the replacement part plus shipping if (1) the part is not under warranty because the source of failure is outside the scope of the warranty, or (2) the warranty period has expired. If there is no warranty coverage, we will send you a detailed letter of explanation.

We also will charge you for the replacement item plus shipping and handling if you do not return the original item within 10 days of the receipt of the replacement item.

### **Instructions for Returning the Original Item**

1. Please use the return label that is included in the box containing the replacement part. The return shipment address is:

Big Ass Fan Company  
ATTN: RMA# \_\_\_\_\_  
800 Winchester Road  
Lexington, KY 40505

2. Use the packaging for the replacement part to return the original part.
3. Include the packing list we have provided which includes the RMA#.
4. If the part weighs over 50 lbs., you will be provided a prepaid Bill Of Lading. To schedule a freight pick up, please contact Customer Service. We will only charge back the freight costs if the original part is not under warranty, or if you do not return the original component within 10 days of receipt of the replacement.
5. If the part weighs 50 lbs. or less, please use the provided prepaid UPS Ground shipping label and drop off at your nearest UPS pickup location.

We apologize for the inconvenience, and appreciate your assistance and cooperation.

If you have questions, please contact us at 1-877-BIG-FANS.

Thank you,  
Big Ass Fan Company

## Warranty claim form instructions

---

1. Complete Warranty Claim Form (see following pages) and Responsibility Agreement (see following pages) and fax them to 859-967-1695, Attn: Customer Service. These pages will be faxed back to you for your records. The Warranty Claim Form will include our acknowledgment and a Return Materials Authorization (RMA) number. **Note: Do not return any item without first being assigned an RMA# by Big Ass Fan Company Customer Service.**
2. No more than 10 days prior to the date you have made arrangements to replace the component part, call Customer Service at 1-877-BIG-FANS to arrange for replacement component delivery and original component pickup. At that time, we will fax you a written acknowledgment of your call that includes a reminder of the return instructions. **Note:** Even if you are not able to replace the component immediately following your initial notice to us, returning the Warranty Claim Form and Responsibility Agreement will effectively stop the warranty clock from running. You can then make the product exchange when you are prepared to do so. However, the warranty period will continue to run until we receive these completed pages back from you, and no warranty will be honored without receipt of these pages within the warranty period. We will not send out any replacement part until you have called to let us know that you have scheduled installation of the replacement. This ensures that the replacement part is not lost or damaged while awaiting installation, and that you are not billed for the replacement because you have waited too long to return the original component (see Responsibility Agreement).
3. When you receive the replacement part, you have 10 working days to remove and replace the existing component and return it to us at **800 Winchester Road, Lexington, KY 40505**.
  - a. Upon receiving the replacement part, verify that replacement part order is correct. If order is incorrect or damaged, notify Big Ass Fan Company within 24 hours after receiving order.
  - b. Use care unpacking the replacement component, as you will need to use BOTH the packaging from the replacement part AND the packing list and a return address label included inside this packaging to return the original part. If the original packaging and return documents are not used, you will be responsible for any damage incurred in transit as well as any additional costs involved. **Note: The RMA# must appear on the outside of the box being returned. Items without an RMA# will not be accepted.**
  - c. Use the delivery service or one of the truck lines specified in the acknowledgement for return of the part. We will refuse receipt of any shipment that is returned via an unauthorized carrier. If you prefer, we can make all arrangements for delivery and pickup.
  - d. Fax a copy of the bill of lading or other tracking information to 859-967-1695 when the item has been shipped so that we know to expect delivery of the original part.
4. If we do not receive the original part back within 15 working days from the date you receive delivery of the replacement, you will be invoiced for the cost of the replacement part, plus freight, on Net 15 terms (see Responsibility Agreement), and this invoice will be due and payable. If you subsequently return the replacement part to us after payment has been made, we will refund any payment made for the replacement part, unless we subsequently determine that the part is not covered under warranty.





800 Winchester Road  
Lexington, KY 40505  
Phone: 1-877-BIG-FANS  
Fax: (859) 967-1695  
www.bigassfans.com

# Warranty Claim Form

Name (print): \_\_\_\_\_ Signature: \_\_\_\_\_

Company: \_\_\_\_\_

Shipping Address: \_\_\_\_\_

City/State/ZIP: \_\_\_\_\_

Phone: \_\_\_\_\_ Fax: \_\_\_\_\_

Items Returned: \_\_\_\_\_ Date of Purchase: \_\_\_\_\_

**Reason(s) for Returning Item** (please provide detail, including length of time after fan had been in operation that problem was noticed, nature of problem, any attempts you made to remedy the problem, etc.):

**ATTENTION: Do not return any item without first being assigned an RMA# by Big Ass Fan Company Customer Service Department. The RMA# must appear on the outside of the box being returned. Items without an RMA# will not be accepted.**

**Date Replacement Parts Should Be Shipped (if known):** \_\_\_\_\_ (Please do not request shipment until you are prepared to install. You may call us at 1-877-BIG-FANS to arrange shipment when you have scheduled installation.)

**Acknowledgment of Receipt of Warranty Return Notification**  
(to be completed by Big Ass Fan Company)

**Acknowledged By:** \_\_\_\_\_ **Date:** \_\_\_\_\_

**RMA#:** \_\_\_\_\_

**Authorized Truck Line(s):** \_\_\_\_\_



800 Winchester Road  
Lexington, KY 40505  
Phone: 1-877-BIG-FANS  
Fax: (859) 967-1695  
www.bigassfans.com

# Responsibility Agreement

To: Big Ass Fan Company

The undersigned understands and acknowledges receipt of the Warranty Claim Form and Instructions and agrees that Big Ass Fans ("Big Ass Fan Company") has the right, upon receipt of returned merchandise, to make final determination as to whether this merchandise should be replaced at no cost under Big Ass Fan Company's stated warranty policy.

The undersigned further agrees that if Big Ass Fan Company determines that this merchandise does not qualify under its stated warranty policy, Big Ass Fan Company can invoice for the replacement merchandise, plus shipping and handling for the original part and all replacements, and such invoice will be paid within 15 days of receipt of the same.

The undersigned agrees to ship to Big Ass Fan Company's location at 800 Winchester Road, Lexington, KY 40505 all of the merchandise replaced by Big Ass Fan Company including, but not limited to, defective or failed components, within 10 working days of the receipt of the any replacements.

The undersigned further agrees that if said replaced merchandise has not been shipped to Big Ass Fan Company within 10 working days, Big Ass Fan Company can invoice for the replacement merchandise plus shipping and handling, and the invoice will be paid within 15 days of receipt.

**Signed:** \_\_\_\_\_

**Title:** \_\_\_\_\_

**For:** \_\_\_\_\_

(Name of Company)

**Date:** \_\_\_\_\_



2348 Innovation Drive  
Lexington, KY 40511  
Phone: 1-859-233-1271  
www.bigasssolutions.com

# Check-In Procedure

(for Big Ass Fans Certified Installers Only)

**ATTENTION: These items must be completed prior to any additional installation crew members entering jobsite or any installation material being unloaded.**

Date: \_\_\_\_\_

Company: \_\_\_\_\_ Job Name: \_\_\_\_\_

Address: \_\_\_\_\_ Purchase Order No.: \_\_\_\_\_

City/State/ZIP: \_\_\_\_\_

Contact Name: \_\_\_\_\_ Phone: \_\_\_\_\_

E-mail: \_\_\_\_\_

**\*\*SEE THE FOLLOWING PAGE FOR NFPA 13 REGULATIONS\*\***

<input type="checkbox"/>	Fan placement is to be in accordance with agreed upon original Scope of Work and Layout. If this is to change, please note change and consult Field Service Manager for approval.
<input type="checkbox"/>	Installation techniques have been discussed (type of conduit, L-brackets if required, mounting technique explained). If the extension tubes exceed 4 ft (1.2 m), guy wires are explained and fully understood.
<input type="checkbox"/>	Times in/out, duration, and schedule presented and accepted.
<input type="checkbox"/>	Time (please list the number of employees and total duration of jobs):   
<input type="checkbox"/>	Safety rules and regulations have been brought to installer's attention (e.g., badges, safety harnesses, vests, hard hats, footwear, lock out/tag out, certification processes, work area free of trash and debris, etc.). If there are any areas that are forbidden or secure, they are brought to the supervisor's attention and instructed not to enter. If there are any special site conditions (i.e., open areas and operating machinery to be avoided), they are also brought to the supervisor's attention and instructed how to bypass the area if required. Safety Rules and Regulations listed:   
<input type="checkbox"/>	The facility manager understands all electrical requirements, i.e., breaker size, voltage, brand, main panel space, and they are in accordance with original Scope of Work and Layout.
	Additional comments:   

# Check-In Procedure (cont.)

(for Big Ass Fans Certified Installers Only)

---

---

## National Fire Protection Association Standard

In accordance with NFPA 13 Standard from the National Fire Prevention Association as referenced in sections 12.1.4 and 11.1.7: High Volume Low Speed (HVLS) Fans:

The installation of HVLS fans in buildings equipped with sprinklers, including ESFR sprinklers, shall comply with the following:

- The maximum fan diameter shall be 24 feet (7.3 m).
- The fan shall be approximately centered between four adjacent sprinklers.
- The vertical clearance from the fan to sprinkler deflector shall be a minimum of 3 feet (0.9 m).
- All fans shall be interlocked to shut down immediately upon receiving a water flow signal from the alarm system in accordance with the requirements of NFPA 72- National Fire Alarm and Signaling Code.

**WARNING: The fan should not be installed unless the structure on which the fan is to be mounted is of sound construction, undamaged, and capable of supporting the loads of the fan and its method of mounting. Verifying the stability of the mounting structure is the sole responsibility of the customer and/or end user, and Big Ass Fans hereby expressly disclaims any liability arising therefrom, or arising from the use of any materials or hardware other than those supplied by Big Ass Fans or otherwise specified in the installation instructions.**

If this installation will be performed outside the scope of work or not within the specifications of Big Ass Fans by customer's request, please provide specific details:

---

---

---

---

Please sign below if both parties agree that all aspects of this installation have been thoroughly explained and are of clear understanding and agreement of the installation to be completed.

**Customer Signature:** \_\_\_\_\_

**Printed Name:** \_\_\_\_\_ **Date:** \_\_\_\_\_

**Contractor Signature:** \_\_\_\_\_

**Printed Name:** \_\_\_\_\_ **Date:** \_\_\_\_\_

The supervisor is to hold all documents until the job is complete and send all forms back to Field Service Manager. This will consist of the service/work order, Check-In document, and Close-Out document. The installation crew will not receive payment until all forms are signed by the facility manager and the supervisor. These documents will then be forwarded to the Field Service Manager at Big Ass Fans.



2348 Innovation Drive  
Lexington, KY 40511  
Phone: 1-859-233-1271  
www.bigasssolutions.com

# Close-Out Procedure

(for Big Ass Fans Certified Installers Only)

Date: \_\_\_\_\_  
Company: \_\_\_\_\_ Job Name: \_\_\_\_\_  
Address: \_\_\_\_\_ Purchase Order No.: \_\_\_\_\_  
City/State/ZIP: \_\_\_\_\_  
Contact Name: \_\_\_\_\_ Phone: \_\_\_\_\_  
E-mail: \_\_\_\_\_

**\*\*SEE THE FOLLOWING PAGE FOR NFPA 13 REGULATIONS\*\***

**The field crew supervisor and facility manager are to walk through the completed installation.**

<input type="checkbox"/>	The installation is complete and on time in accordance with the original Check-In document. If not, explain:
<input type="checkbox"/>	Conduit runs are installed in accordance with the Check-In document, Scope of Work, and Layout. If not, explain:
<input type="checkbox"/>	The fans are correctly placed in accordance with both the Check-In document, Scope of Work, and Layout. If not, explain:
<input type="checkbox"/>	Breaker size and wire type are in accordance with the Check-In document, Scope of Work, and Layout. If not, explain:
<input type="checkbox"/>	All safety rules and regulations met in accordance with the Check-In document, Scope of Work, and Layout. If not, explain:
<input type="checkbox"/>	Fans have been running for over an hour and operate without visible defect or issue.
<input type="checkbox"/>	The fan is spinning in the correct direction (counterclockwise when viewed from floor).
<input type="checkbox"/>	Angle irons are securely fastened and are without any apparent problems in accordance with installation techniques discussed at check-in.
<input type="checkbox"/>	If extension tube is 4 ft (1.2 m) or longer, guy wires are in place and there is no evidence of a wobble.
<input type="checkbox"/>	Supervisor or contractor has supplied and explained the Installation Guide. If not, explain:
<input type="checkbox"/>	The supervisor or contractor has explained and I understand how to operate fan including starting/stopping, speed operation, and power disconnect. If not, explain:
<input type="checkbox"/>	Time in/out and duration are in accordance with Check-In document.
	Additional comments:

# Close-Out Procedure (cont.)

(for Big Ass Fans Certified Installers Only)

---

---

## National Fire Protection Association Standard

In accordance with NFPA 13 Standard from the National Fire Prevention Association as referenced in sections 12.1.4 and 11.1.7: High Volume Low Speed (HVLS) Fans:

The installation of HVLS fans in buildings equipped with sprinklers, including ESFR sprinklers, shall comply with the following:

- The maximum fan diameter shall be 24 feet (7.3 m).
- The fan shall be approximately centered between four adjacent sprinklers.
- The vertical clearance from the fan to sprinkler deflector shall be a minimum of 3 feet (0.9 m).
- All fans shall be interlocked to shut down immediately upon receiving a water flow signal from the alarm system in accordance with the requirements of NFPA 72- National Fire Alarm and Signaling Code.

**WARNING: The fan should not be installed unless the structure on which the fan is to be mounted is of sound construction, undamaged, and capable of supporting the loads of the fan and its method of mounting. Verifying the stability of the mounting structure is the sole responsibility of the customer and/or end user, and Big Ass Fans hereby expressly disclaims any liability arising therefrom, or arising from the use of any materials or hardware other than those supplied by Big Ass Fans or otherwise specified in the installation instructions.**

**NOTE: The customer's initials are required as acknowledgement for the following instances:**

- \_\_\_ Return Trip Required – Additional Charges Apply (Customer not Ready/Lift Issues)
- \_\_\_ Work Completed Outside Scope of Work (if applicable)
- \_\_\_ Installation Not Performed Per BAF Recommendations or Specifications For Any Reason
- \_\_\_ Customer Understands and Approves Additional Charges As Explained in amount of \$\_\_\_\_\_ (if applicable)
- \_\_\_ Other (Please Explain Below)

If any portion of this installation was performed outside the scope of work or not within the specifications of Big Ass Fans at any capacity or for any reason, please provide specific details below:

---

---

---

---

Signatures of both parties are **required** below to acknowledge that this installation has been completed to customer's satisfaction, to activate fan(s) warranty, and to issue payment to contractor (with required documentation):

**Customer Signature:** \_\_\_\_\_

**Printed Name:** \_\_\_\_\_ **Date:** \_\_\_\_\_

**Contractor Signature:** \_\_\_\_\_

**Printed Name:** \_\_\_\_\_ **Date:** \_\_\_\_\_

The supervisor is to hold all documents until the job is complete and send all forms back to Field Service Manager. This will consist of the service/work order, Check-In document, and Close-Out document. The installation crew will not receive payment until all forms are signed by the facility manager and the supervisor. These documents will then be forwarded to the Field Service Manager at Big Ass Fans.







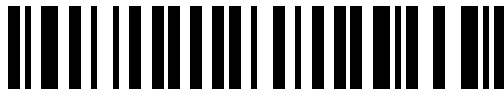

1001010801

Rev. M



**BIGASS**<sup>®</sup>  
FANS

2425 Merchant St., Lexington, KY 40511  
1 (877) BIG-FANS | [WWW.BIGASSFANS.COM](http://WWW.BIGASSFANS.COM)