



AirGo

Air. On the go. NOW!

The rugged, 8-ft (2.4-m) vertical AirGo® delivers airflow half the length of a football field, yet is quiet enough to carry on a conversation directly in front of the fan. From the heavy-duty steel tubing and the rigid screen, to the high efficiency motor and gearbox, AirGo is made from all-welded construction by hand for unmatched durability. Fully assembled and no installation required, AirGo delivers the breeze without delay – where and when you need it most.



Features and Benefits:

- Factory pre-assembled, no installation needed
- Standard with indoor/outdoor wheels with rubber tread
- Optional All-Terrain package features oversized tires, a wider base and four-wheel steering for increased mobility
- Simply plug AirGo into any 110 V, 15 A receptacle
- Operates at only 67.4 dBA at maximum speed for non-disruptive airflow
- Floor-to-ceiling coverage with easy adjustment of rugged quick-lock handles
- Perfect for aisle ways, compact work areas and spaces with low ceilings
- Heavy gauge steel frame and cage provide protection in the toughest environments
- Available in two colors - powder coated "safety yellow" or "wedding white" for any occasion
- Approximately 6,000-sq-ft of floor coverage area
- Cooling breeze measured at 140 feet (42.7 meters)
- Optional mister accessory provides ultra-fine cloud of mist that reduces temperatures by up to 25°F (14°C)

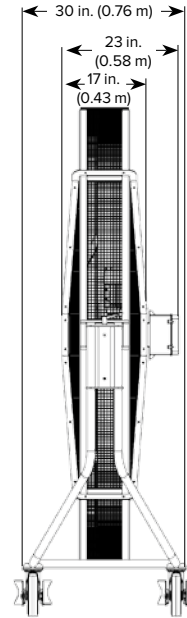
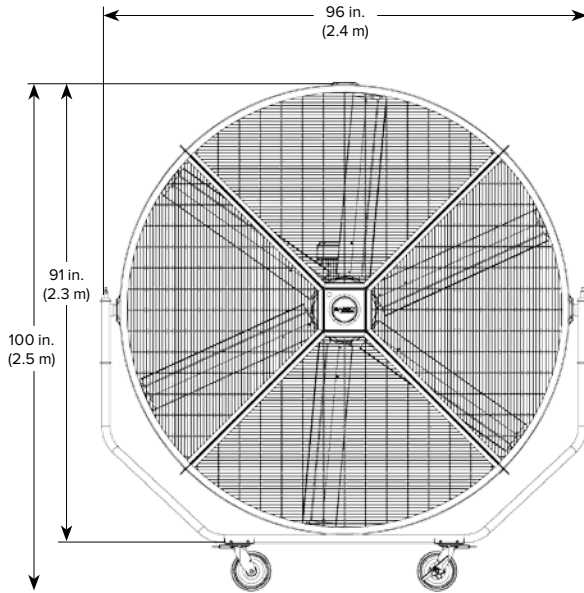

Technical Specifications

Dimensions (W x H x D)	96 x 100 x 30 in. (2.4 x 2.5 x 0.76 m)
Cage	OSHA compliant
Controller	AirGo variable speed control
Input power	100–125 VAC, 1 Φ , 15 A
Motor	0.5 HP (0.37 kW)
Maximum speed	180 RPM
Maximum amps	12 A
Sound level (maximum speed)*	67.4 dBA
Weight (as shown)	450 lb
Certification	ETL certified to ANSI/UL 507, CAN/CSA C22.2 No. 113
Warranty	3 years in the US and Canada**

*Fans are sound tested at maximum speed in a laboratory environment. Actual results in field conditions may vary due to sound reflecting surfaces and environmental conditions.

**3 years parts, lifetime airfoils and hub, 1 year labor warranty available in the US and Canada; certain exclusions may apply. Warranties vary by country. See complete warranty for details.

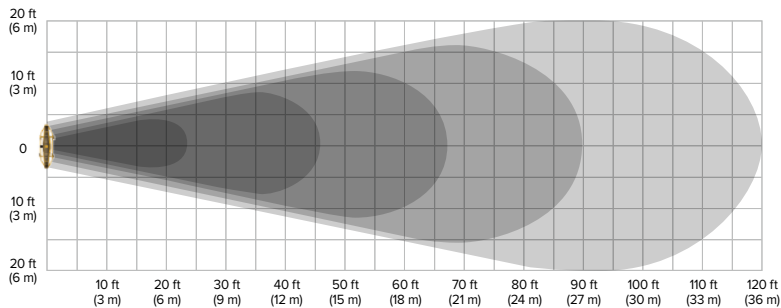

AirGo Air Velocity

- Shaded area represents effective cooling area
- Darker shaded areas represent higher air velocities
- Air velocities range from 375 fpm to 129 fpm (to 120')
- fpm = feet per minute

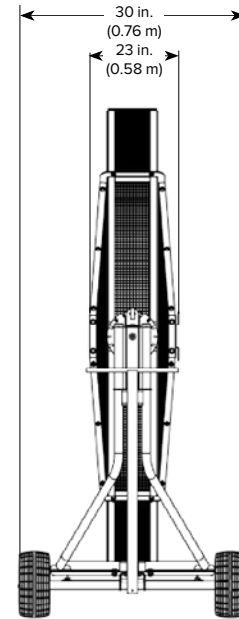
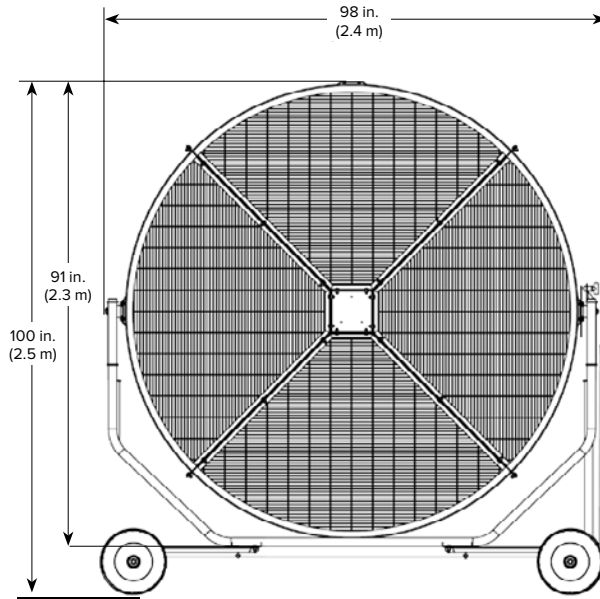

Technical Specifications

Dimensions (W x H x D)	98 x 100 x 44.5 in. (2.4 x 2.5 x 1.13 m)
Cage	OSHA compliant
Controller	AirGo variable speed control
Input power	100–125 VAC, 1 Φ , 15 A
Motor	0.5 HP (0.37 kW)
Maximum speed	180 RPM
Maximum amps	12 A
Sound level (maximum speed)*	67.4 dBA
Weight (as shown)	600 lb (272 kg)
Warranty	3 years in the US and Canada**

*dBA as measured 20 ft (6.1 m) from fan center, background noise ~ 33–36 dBA

**3 years parts, lifetime airfoils and hub, 1 year labor warranty available in US and Canada; certain exclusions may apply. Warranties vary by country. See complete warranty for details.

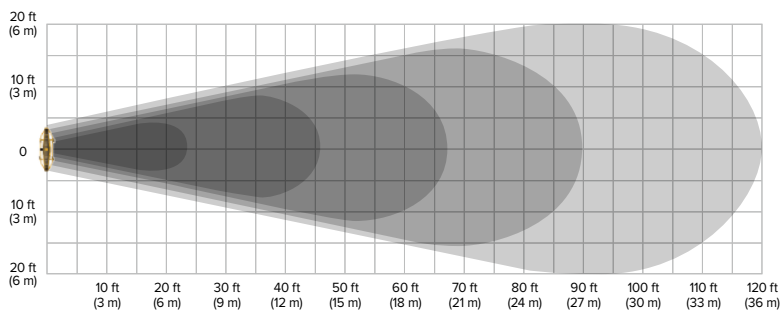

AirGo Air Velocity

- Shaded area represents effective cooling area
- Darker shaded areas represent higher air velocities
- Air velocities range from 375 fpm to 129 fpm (to 120')
- fpm = feet per minute



AirGo Mister Kit

TECHNICAL SPECIFICATIONS

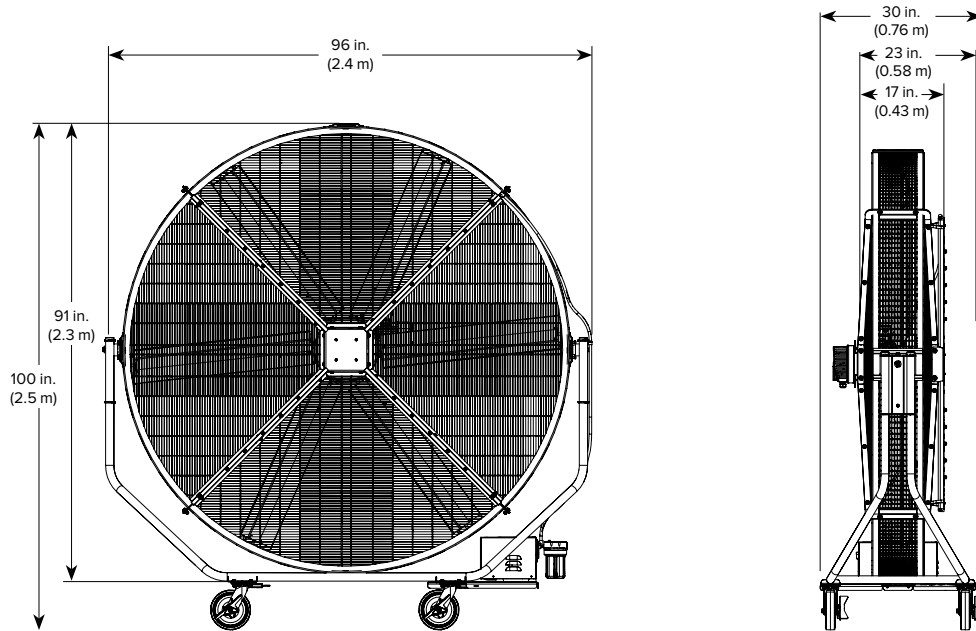

Technical Specifications

	Misting pump
Maximum pressure	1000 PSI; high pressure
Maximum flow	0.5 GPM
Voltage	110-120 VAC, 60 hz, 5A
HP	0.5 HP (0.372 kw)
Filter	Water supply in-line, 5-micron filter
Water Source	Accepts standard garden hose

Kit Components

Includes 8-ft (2.4 m) outdoor-rated power cord with integrated GFCI

Benefits

Ultra fine cloud of mist absorbs heat in the air, reducing temperatures by up to 25°F

