



# Invisidor STYLE Air Curtain

## Installation, Operation & Maintenance Manual

Version 2.0

English

## Copyright

All the information and drawings in this manual are the property of Biddle and may not be used (other than for the actual operation of the device), photocopied, duplicated, translated and/or be brought to the attention of third parties without Biddle's prior written permission.

The name Biddle is a registered trademark.

## Warranty and liability

Please refer to Biddle's Terms of Sales and Delivery for warranty and liability conditions.

Biddle excludes liability for consequential loss at all times and under all circumstances.

## Liability for the contents of this manual

However much care might have been taken in ensuring the correctness and, where necessary, completeness of the description of the relevant parts, Biddle disclaims all liability for damage resulting from any inaccuracies and/or deficiencies in this manual.

Should you detect any errors or ambiguities in this manual then we would be pleased to hear from you: it helps us to improve our documentation even further.

Biddle retains the right to change the specifications stated in this manual.

## For more information

If you have any comments or questions about specific topics relating to this product, please do not hesitate to contact Biddle.

## Addresses

United Kingdom

Biddle Air Systems Ltd.  
St. Mary's Road  
Nuneaton  
Warwickshire CV11 5AU  
United Kingdom

Tel: +44 (0)24 7638 4233

Fax: +44 (0)24 7637 3621

e-mail: [sales@biddle-air.co.uk](mailto:sales@biddle-air.co.uk)

internet: [www.biddle-air.com](http://www.biddle-air.com)

# Contents

<b>1 INTRODUCTION</b> .....	<b>4</b>
1.1 About this manual .....	4
1.2 Delivery Check .....	4
1.3 Safety and Electrical Connections .....	4
1.4 Technical Data Table.....	5
<b>2 INSTALLATION</b> .....	<b>6</b>
2.1 Horizontal Style Air Curtain .....	6
2.1.1 Location.....	6
2.1.2 Wall and Ceiling Fixing .....	6
2.1.3 Lifting with Eye Bolts .....	6
2.1.4 Multiple Air Curtains .....	7
2.2 Vertical Style Air Curtain .....	11
2.2.1 Location.....	11
2.2.2 Floor Fixing.....	11
2.2.3 Stacking Air Curtains .....	12
2.3 LPHW Models.....	12
2.4 Mounting and Connecting Controller .....	15
<b>3 OPERATIONS</b> .....	<b>19</b>
3.1 Remote Controller Operations and DIP Switch Settings.....	19
3.2 Tailoring the System .....	20
3.3 External Controls .....	21
3.4 Multiple Installation .....	22
<b>4 COMMISSIONING</b> .....	<b>22</b>
4.1 Transformer Speed Controller.....	23
4.2 PCB Status .....	23
<b>5 FAULT CONDITIONS</b> .....	<b>24</b>
5.1 User Fault Finding Flowchart.....	25
<b>6 SERVICE &amp; MAINTENANCE</b> .....	<b>26</b>

# 1 Introduction

## 1.1 About this manual

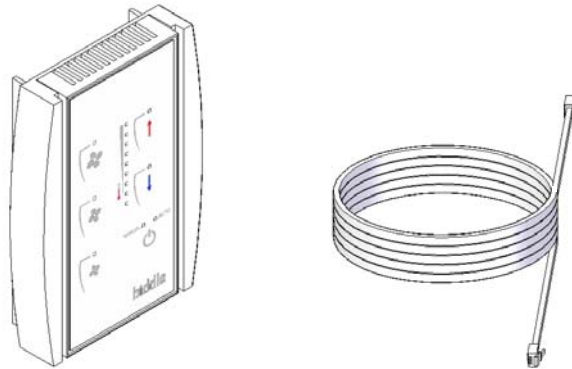

This manual describes the installation, operation and maintenance of the Invisidor Style air curtain unit. The manual also provides information on service and fault conditions.

## 1.2 Delivery Check

Check the unit and all its packaging for correct delivery. Make sure that all components and accompanying parts have been supplied. Immediately report to the supplier if anything is missing or damaged

## 1.3 Safety and Electrical Connections

***All electrical wiring and connections MUST be carried out by a competent qualified electrician in accordance with the latest edition of the IEE wiring regulations and/or local statutory regulations.***

- A single phase or 3 phase local isolator with a contact separation of at least 3mm on all poles must be fitted in the electrical supply wiring to the air curtain located in an accessible position.
- The air curtain must be earthed.
- The appliance must be connected using cables having an appropriate temperature rating (heat resistant). For two air curtains in a vertical stack, electrical power must be connected separately to the bottom air curtain and to the top air curtain. NB The electrical supply to the top air curtain may be routed via the bottom air curtain.
- Ensure that the supply cables, circuit breakers and other electrical installation equipment are correctly sized for the air curtain being installed; see Table 1 for Power Ratings. See also data badge inside of unit adjacent to electrical inlet.
- On a 3 phase electrical supply the unit requires a neutral connection (3N~).
- Cable glands used for the Electrical Input must be rated IP21 or higher.

**Attention:** For stainless steel units the inlet casing and back casings are coated in an easy to peel protective film. Please ensure all the protective film is removed before the air curtain is put into service.

## 1.4 Technical Data Table

**Table 1 Product Code and Electrical Specification**

Air Curtain		Electrical Supply (V/ph/Hz)	Rated Power Input (kW)	Current per phase (A)	Heat Output (kW)	Weight (kg)
<b>Ambient Units</b>						
Style 100A H		230/1/50	0.30	1.5	N/A	59
Style 150A H, Style 150A V		230/1/50	0.40	2.0	N/A	72
Style 200A H, Style 200A V		230/1/50	0.60	2.9	N/A	98
Style 250A V (Stacked Unit)	Top air curtain	230/1/50	0.30	1.5	N/A	131
	Bottom air curtain	230/1/50	0.40	2.0	N/A	
Style 300A V (Stacked Unit)	Top air curtain	230/1/50	0.30	1.5	N/A	157
	Bottom air curtain	230/1/50	0.60	2.9	N/A	
<b>Water Heated Units</b>						
Style 100W H		230/1/50	0.30	1.3	See Quotation	66
Style 150W H, Style 150W V		230/1/50	0.40	1.8		82
Style 200W H, Style 200W V		230/1/50	0.60	2.7		112
Style 250W V (Stacked Unit)	Top air curtain	230/1/50	0.30	1.3		148
	Bottom air curtain	230/1/50	0.40	1.8		
Style 300W V (Stacked Unit)	Top air curtain	230/1/50	0.30	1.3		178
	Bottom air curtain	230/1/50	0.60	2.7		
<b>Electric Heated Units</b>						
Style 100E H		400/3/50	12.30	18.7	6.0/12.0	62
Style 150E H, Style 150E V		400/3/50	18.40	27.9	9.0/18.0	76
Style 200E H, Style 200E V		400/3/50	24.60	37.5	12.0/24.0	104
Style 250E V (Stacked Unit)	Top air curtain	400/3/50	12.30	18.7	6.0/12.0	138
	Bottom air curtain	400/3/50	18.40	27.9	9.0/18.0	
Style 300E V (Stacked Unit)	Top air curtain	400/3/50	12.30	18.7	6.0/12.0	166
	Bottom air curtain	400/3/50	24.60	37.5	12.0/24.0	

Above information based on high fan speed operation. Weights include 6kg for hanging brackets used with a horizontal overdoor unit. Foot plate for vertical unit weighs 16kg. Vertical stacked units require a top support wall bracket which weighs 3kg.

# 2 Installation

## 2.1 Horizontal Style Air Curtain

**The Invisidor Style air curtain should be surface mounted inside the doorway and not exposed to the external environment or moist conditions. It should not be built-in or recessed in any way.**

### 2.1.1 Location

Ensure that the unit is mounted within its height specification of 1.8m to 3.2m maximum (from floor level to the underside of the unit) with the air discharge grille positioned nearest to the door. The air curtain should be located as close to the door opening as possible for best performance, obstructions such as door opening devices, structural beams etc will reduce the efficiency of the air curtain. There must be at least 200mm clearance at the air inlet for air to enter the air curtain, see Figure 3, Figure 4 and Figure 5.

For maximum effectiveness it is essential to ensure the width of the air curtain is slightly wider than the width of the door when it is open.

Using the 2.5mm hexagon key wrench supplied, unfasten and remove all casing screws from air curtain inlet grille and carefully detach the casing. All screws should be kept safe as they will be required later in the installation.

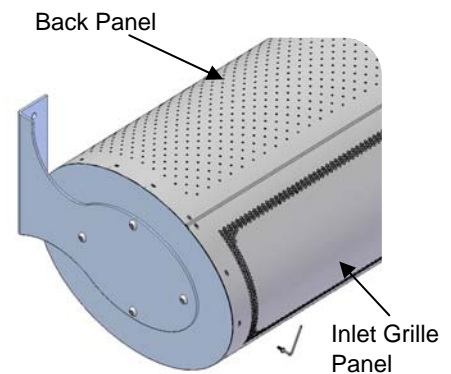

### 2.1.2 Wall and Ceiling Fixing

Before fitting the unit to the wall or ceiling ensure suitable wall fixing bolts are used, taking into account unit weight (see Table 1)\*.

Style horizontal air curtains are supplied with two steel wall or ceiling brackets fitted to each end of the unit. Refer to Figure 3 for wall mounting details and Figure 4 and Figure 5 for ceiling mounting details.

Ensure all fixings are correctly fitted and securely tightened. Figure 5 shows special ceiling bracket for use with drop rod covers designed to hide services.

\* It is the sole responsibility of the installer to ensure that all the fixing points and suspension system used are suitable for the air curtain being installed.

### 2.1.3 Lifting with Eye Bolts

A set of eye bolts are supplied with each horizontal air curtain to assist vertical lifting and positioning of wall and ceiling mounted air curtains. The back panel case should be removed before lifting air curtain into position with eye bolts. Using appropriate lifting equipment plan the safe and secure lift of the air curtain. Each eye bolt should be located and secured, as detailed in Figure 1, ensuring all the nuts are securely tightened. Remove all eyebolts once the air curtain has been safely lifted and secured into position.

## ALWAYS

- Ensure lifting operations are planned, supervised and carried out in a safe manner
- Ensure all lifting equipment and accessories are free of damage and suitable for the proposed use
- Attach lifting equipment securely to the load ensuring load will remain stable when lifted
- Ensure the load is balanced and will not tilt or fall
- Refer to the relevant local or statutory codes for safe lifting practices

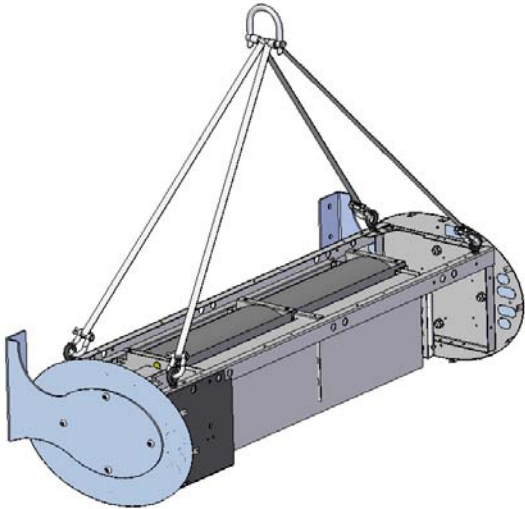

## NEVER

- Allow inexperienced personnel to operate lifting equipment
- Use damaged accessories or equipment
- Attempt to shorten, twist, knot or tie slings
- Overload slings
- Hammer, force or wedge slings or accessories into position
- Allow personnel to ride on loads
- Stand directly below the load whilst lifting

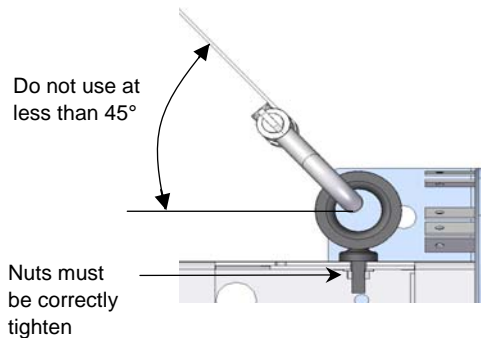

**Figure 1 Lifting Air Curtain with Eye Bolts**

### 2.1.4 Multiple Air Curtains

For multiple air curtains joined together over a doorway an additional wall bracket (6811940) or ceiling bracket (6811950) must be fitted at each joining point, refer below to Figure 2. Inlet casings should only be fitted after all functional tests have been completed and verified (refer to section 4 - Commissioning).

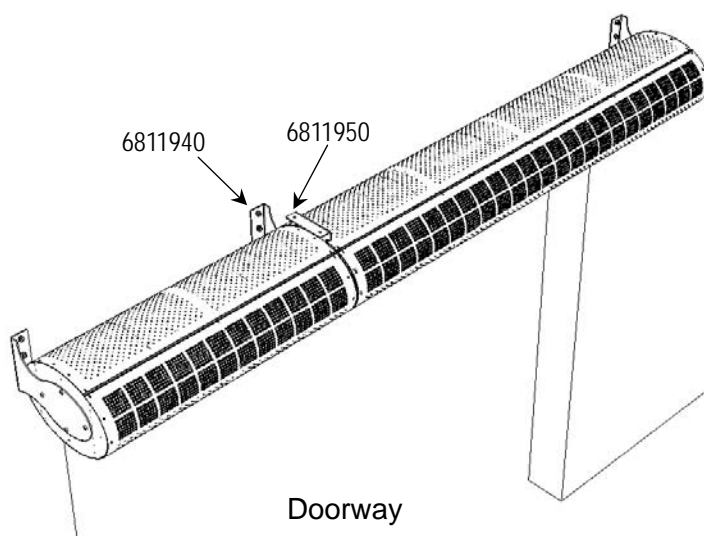

**Figure 2 Horizontal Multiple Installation above Doorway**

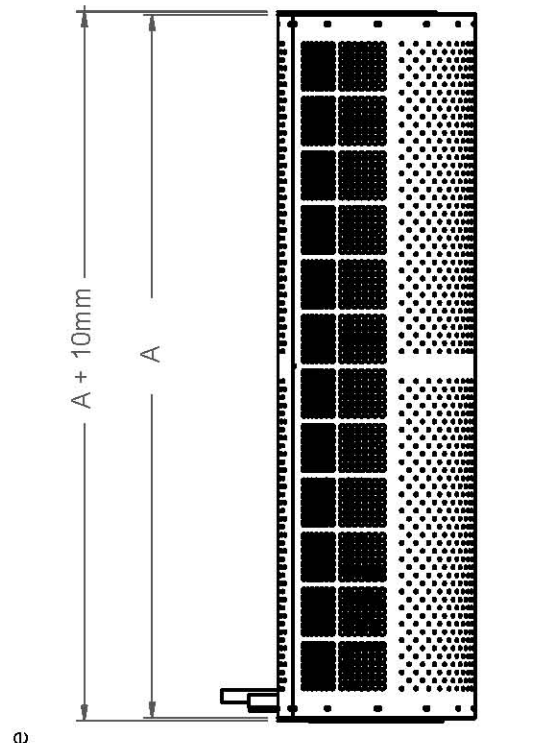

A (mm)	STYLE 100H	STYLE 150H	STYLE 200H
	1250	1712	2345

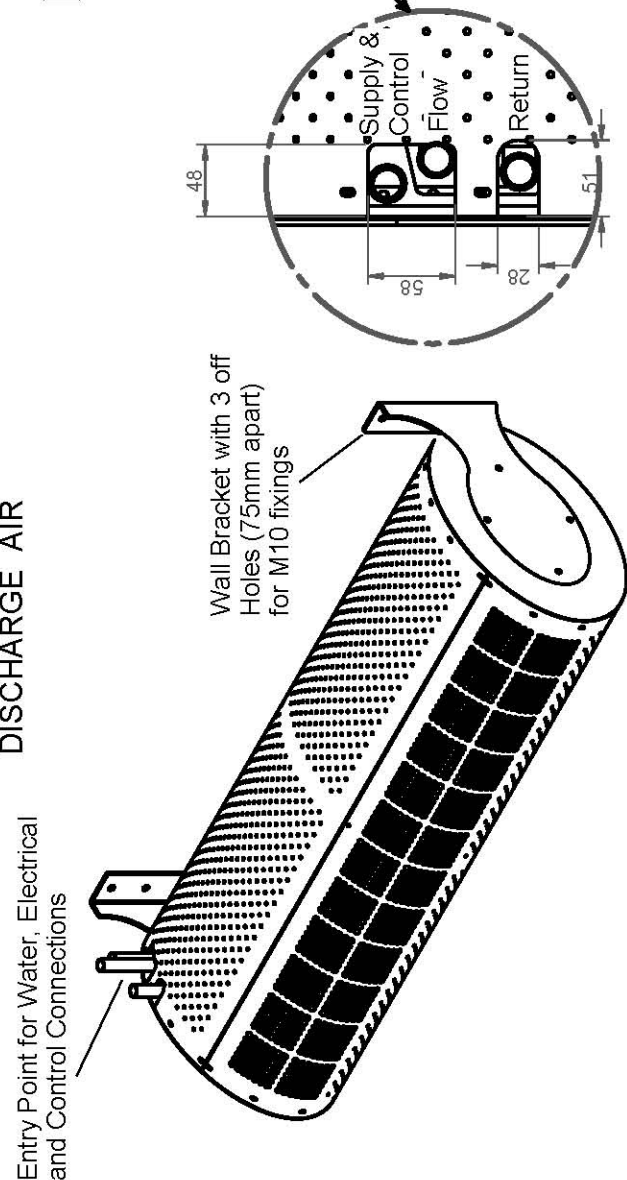

**Figure 3 Wall Mounted Horizontal Style Air Curtain**

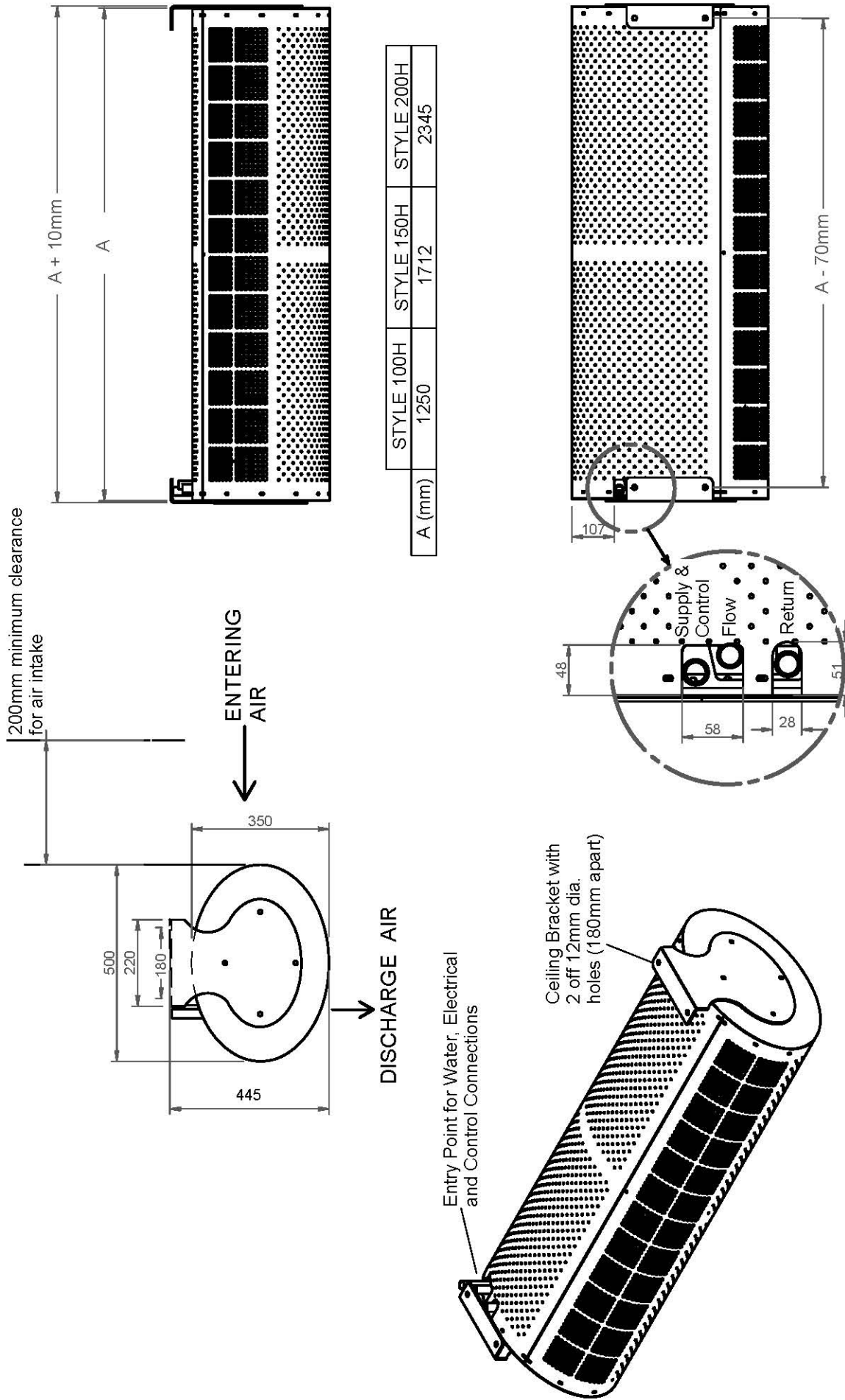

**Figure 4 Ceiling Mounted Horizontal Style Air Curtain**

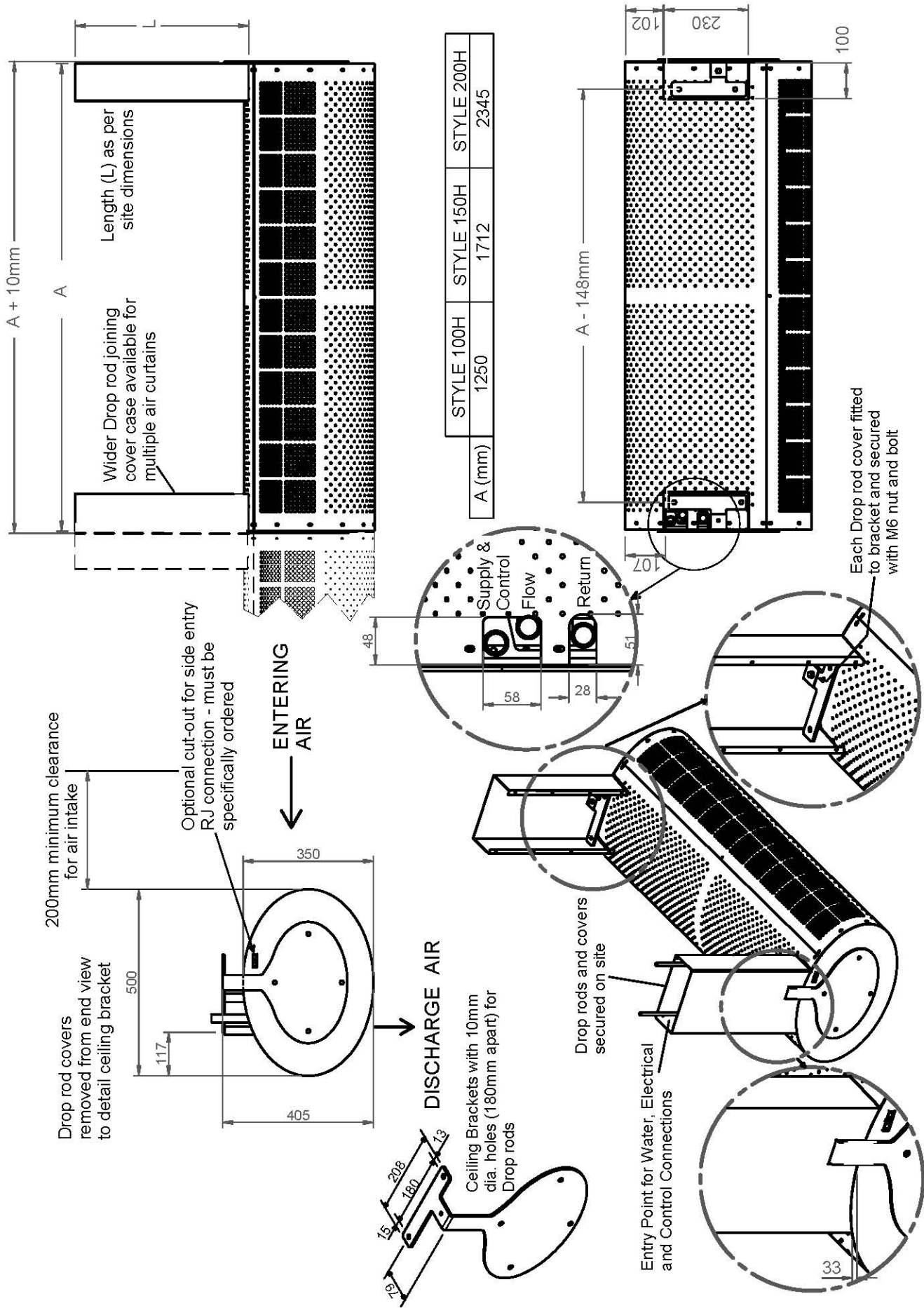

**Figure 5 Ceiling Mounted Style Air Curtain with Drop Rod Covers**

## 2.2 Vertical Style Air Curtain

The air curtain must be surface mounted within the building and not exposed to the external environment or moist conditions. Do not install the air curtain in a doorway situation where there is a likelihood, or there has been a history of, rain ingress. The air curtain must not be built into a compartment or recessed.

### 2.2.1 Location

Prior to commencing any vertical installation it is essential to ensure the correct handing has been selected, i.e. Left Hand (LH) or Right Hand (RH) - see "Handing Guide" in Figure 6. Maximum doorway width = 2.5m per air curtain.

For maximum effectiveness it is essential to ensure the height of the air curtain is slightly higher than the opening height of the door. Obstructions such as door opening devices, structural beams etc will reduce the efficiency of the air curtain. There must be at least 200mm clearance at the air inlet for air to enter the unit, see Figure 6.

### 2.2.2 Floor Fixing

Using the 2.5mm hexagon key wrench supplied, unfasten and remove all the casing screws from the air curtain and carefully detach both sections of casing. All screws should be kept safe as they will be required later in the installation.

Before installing the Style air curtain obtain four suitable fixing bolts, taking into account floor type and unit weight (see Table 1)\*. Rawlplug<sup>®</sup> M10 Projecting Rawlbolt<sup>®</sup> 44356 type may be suitable. For dimensional details refer to the general assembly drawing, Figure 6.

Style vertical air curtains are supplied with the foot plate fitted. Determine and place the unit at its most favourable position. A wall bracket must be fitted to the top of the unit for Style 250V and Style 300V stacked air curtains to tether the top of the unit to the wall. In order to use the wall bracket supplied ensure the back of the foot plate is no more than 25mm away from the wall. If skirting board, with maximum depth of 25mm is fitted, ensure the back of the foot plate is touching the skirting board.

Using the foot plate as a template, mark the location of the four holes, as indicated in the adjacent picture. Using a suitable masonry drill bit, correctly drill the four marked out holes. Place M10 fixing bolts into each hole, ensuring all bolts are upright.

Reposition the air curtain foot plate over the projecting bolts. Tighten each M10 nut as indicated in the adjacent picture. Ensure the vertical unit is secure, upright and square.



Using a hacksaw carefully cut the projecting bolts flush with the nut, ensuring the foot plate is not damaged or marked in any way.



\* It is the sole responsibility of the installer to ensure that the floor and any fixing points are suitable for the air curtain being installed.

Remove only one M10 nut and refit and secure bolt with a stainless steel M10 dome nut supplied. Repeat for each of the other three projecting bolts one at a time.

Both sections of the casing should be fitted only after all functional tests have been completed and verified (see Commissioning).

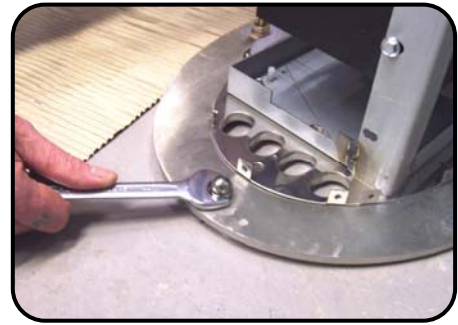

### 2.2.3 Stacking Air Curtains

Only a single Style 100 stacking vertical air curtain should be mounted on top of another vertical unit.

Using fixing kit components supplied, the vertical stack frames are joined together using four M8 x 35mm hexagonal bolts and M8 nuts (see picture). Feed each hexagonal bolt from the top unit and fasten with M8 nuts. All stacked units must be secured with a wall bracket at the top of the stack, refer to Figure 6.

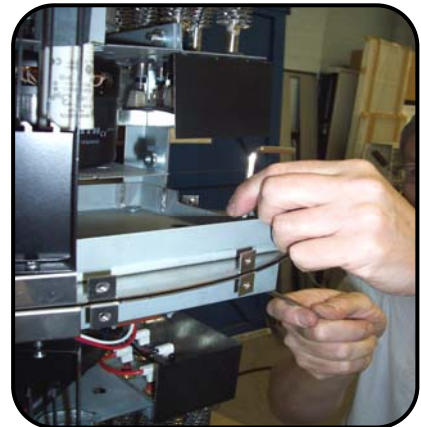

## 2.3 LPHW Models

For LPHW models ensure suitable water isolating valves, as detailed below, are fitted to both the flow and return pipework.

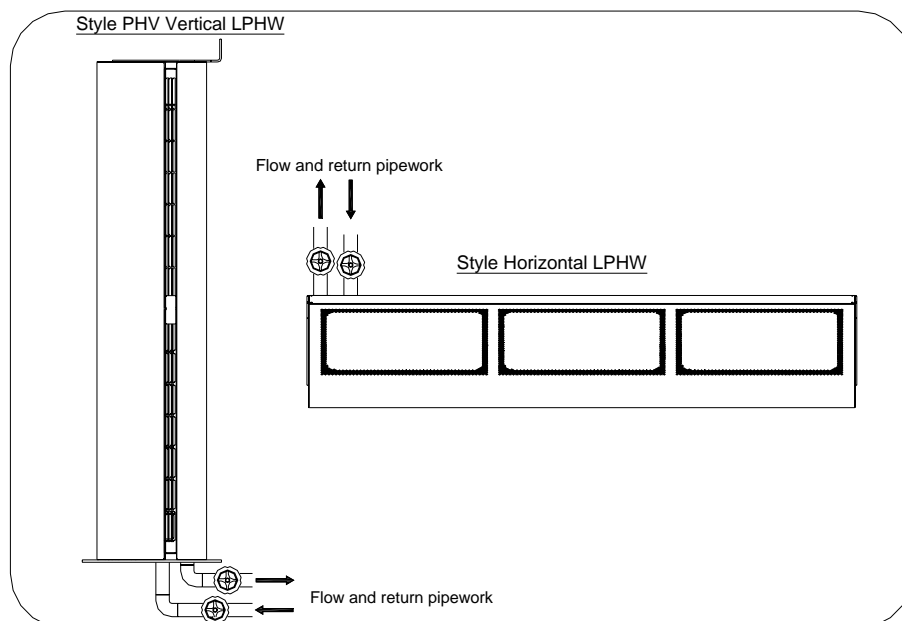

For the Style air curtain the 3 port valve is fitted inside each unit. There must be a removable section of pipe between the isolating valve in the flow pipe and the inlet into the 3-port valve, to allow for removal of the 3 port valve if it ever needs to be replaced.

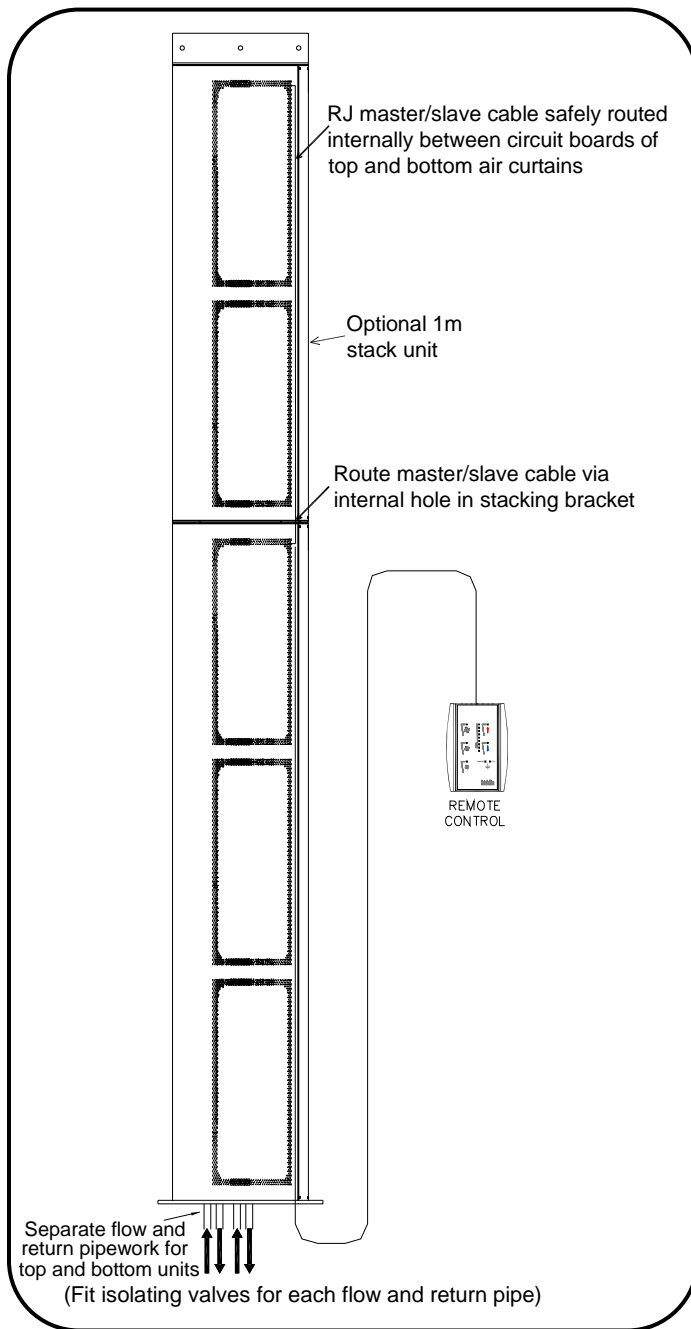

Each Style LPHW air curtain is fitted with the 3 port valve inside the casing of the air curtain. For two air curtains in a stack each air curtain requires its own separate water flow and return connection.

In order to obtain optimum heat output, all air from the system and the heating coil must be vented.

200mm minimum clearance for air intake

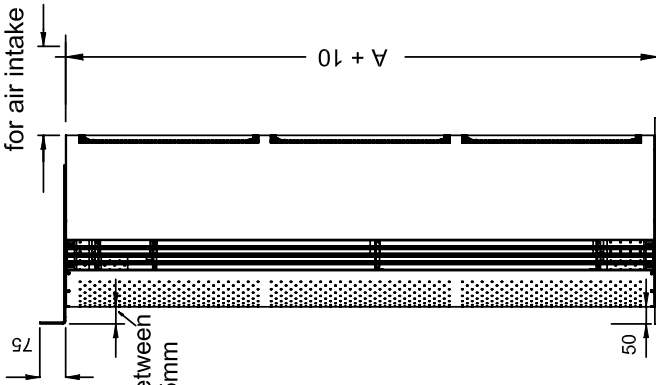

Adjustable between 50mm to 75mm

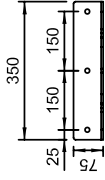

**END VIEW**

Wall Bracket for stacked STYLE 250V and STYLE 300V units

3 Holes (150mm apart) for M10 fixings  
Optional Entry Point for Water and Electrical Connections - must be specifically ordered

A(mm)	STYLE 150V	STYLE 200V	STYLE 250V	STYLE 300V
	1712	2345	2962	3609

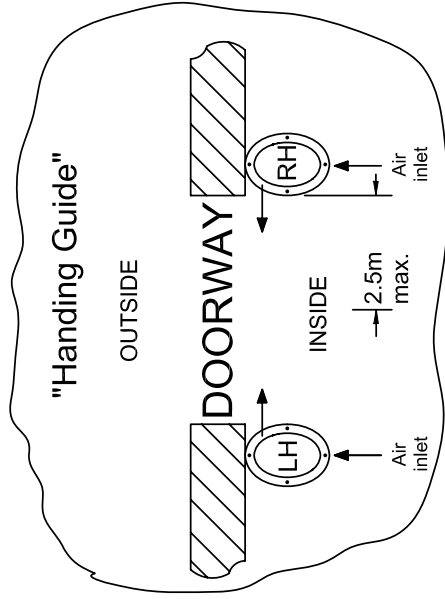

DISCHARGE AIR  
ENTERING AIR

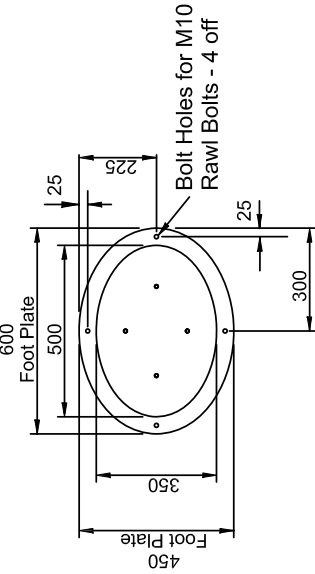

Standard Entry Point for Water and Electrical Connections if entry via floor void

As Drawn for R.H.  
Opposite Hand for L.H.

**Figure 6 Vertical Mounted Style Air Curtain**

## 2.4 Mounting and Connecting Controller

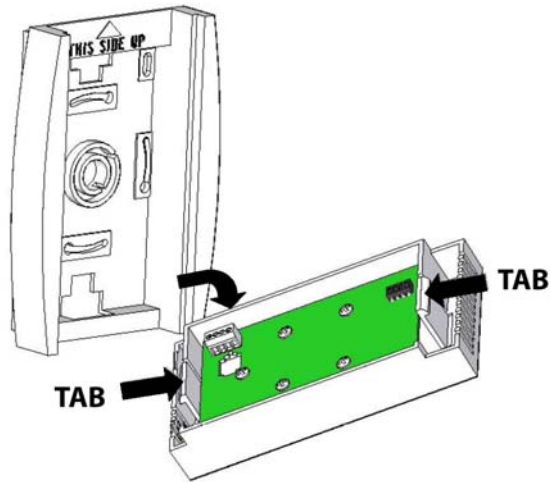

Remove the controller front case from the back case by pressing on the two top and bottom tabs and pulling the two cases apart.

The controller should be located in a suitable place for easy access, it can be fixed to the wall via various fixing slots provided in the back case.

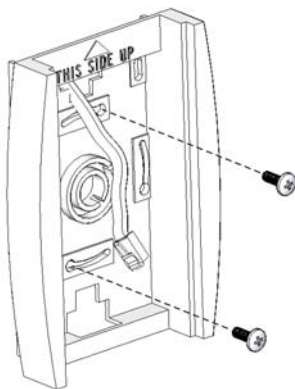

Feed the control cable from the air curtain through the opening in the back case (see insert). Using suitable fixing screws secure back case to wall.

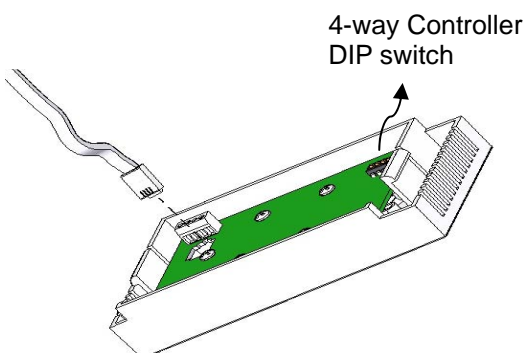

Link the RJ plug from the control cable to the RJ socket on the controller PCB. Refit the controller front case to the back case.

**Note:** For controller DIP switch options and settings refer to section 3.1 (Remote Controller Operations and DIP Switch Settings).

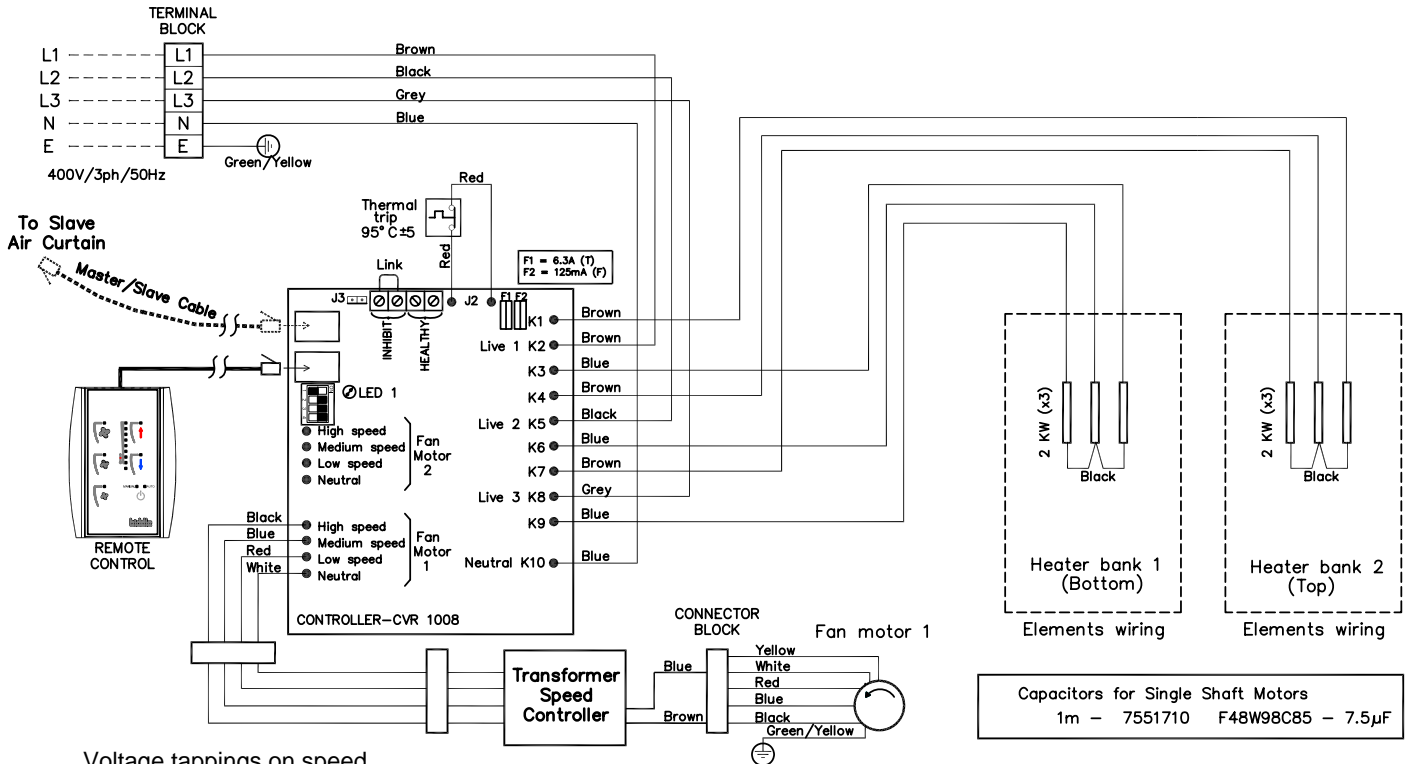

Voltage tapings on speed controller can be re-set to adjust fan speeds to suit site conditions

### Style 100E H and Style 100E V\*

\* used as top air curtain for vertical stacking only

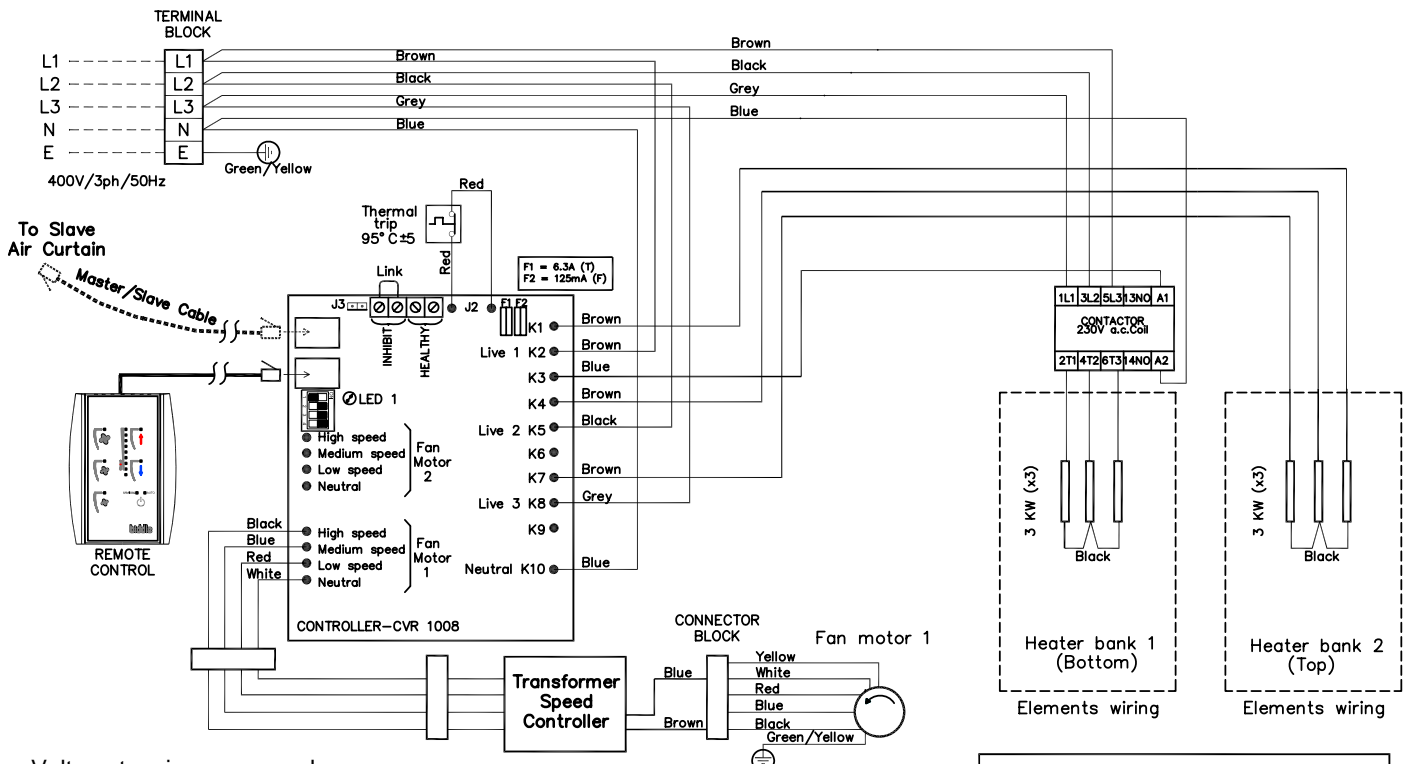

Voltage tapings on speed controller can be re-set to adjust fan speeds to suit site conditions

### Style 150E H and Style 150E V



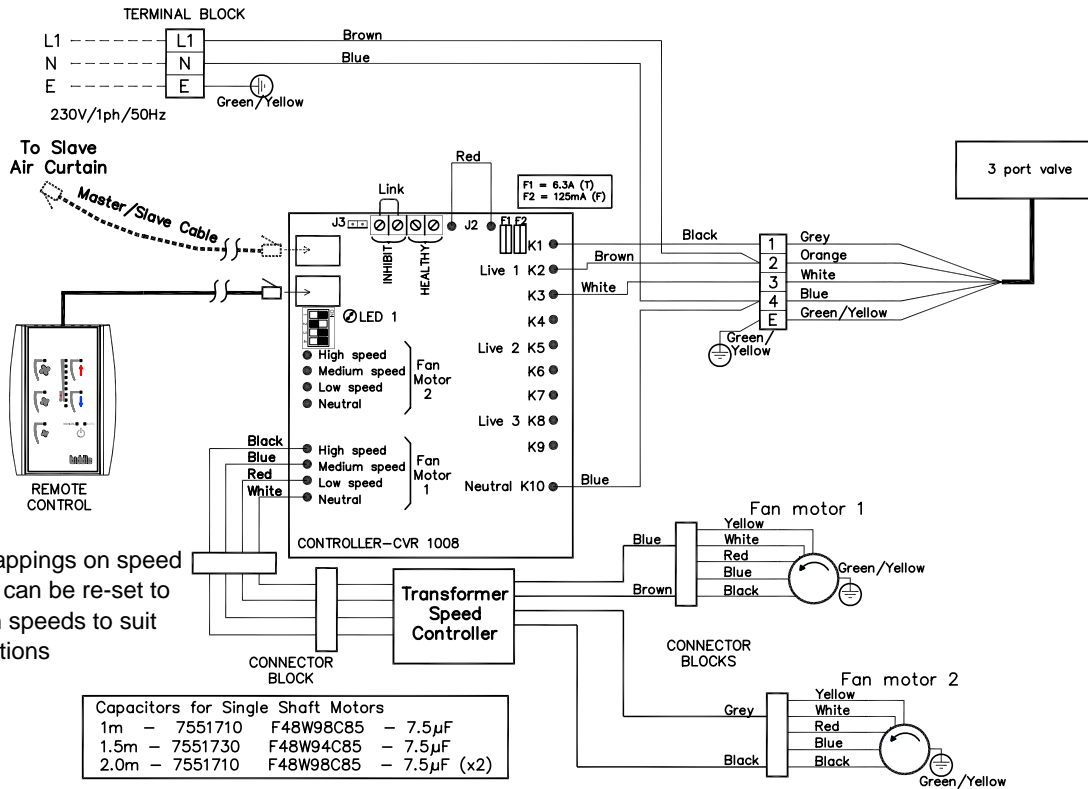

Voltage tappings on speed controller can be re-set to adjust fan speeds to suit site conditions

**Style 100W H, Style 150W H, Style 200W H, Style 100W V\*, Style 150W V and Style 200W V**

\* used only as top air curtain for vertical stacking

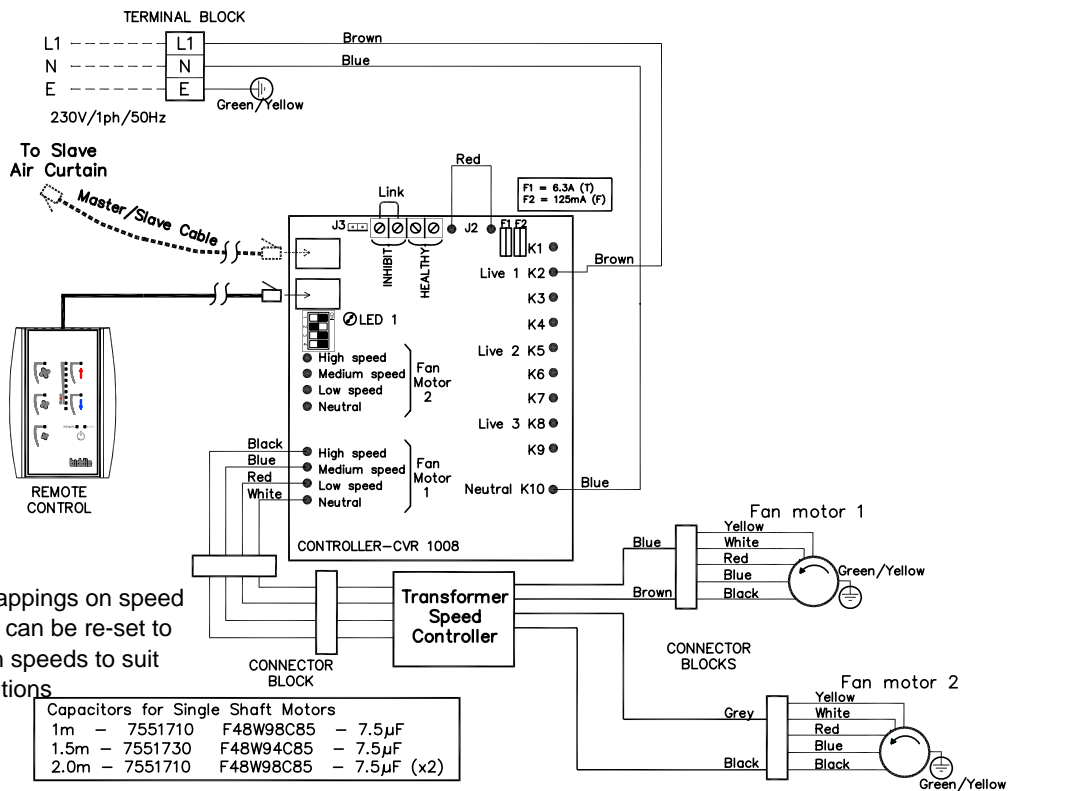

Voltage tappings on speed controller can be re-set to adjust fan speeds to suit site conditions

**Style 100A H, Style 150A H, Style 200A H, Style 100A V\*, Style 150A V and Style 200A V**

\* used only as top air curtain for vertical stacking

# 3 Operations

## 3.1 Remote Controller Operations and DIP Switch Settings

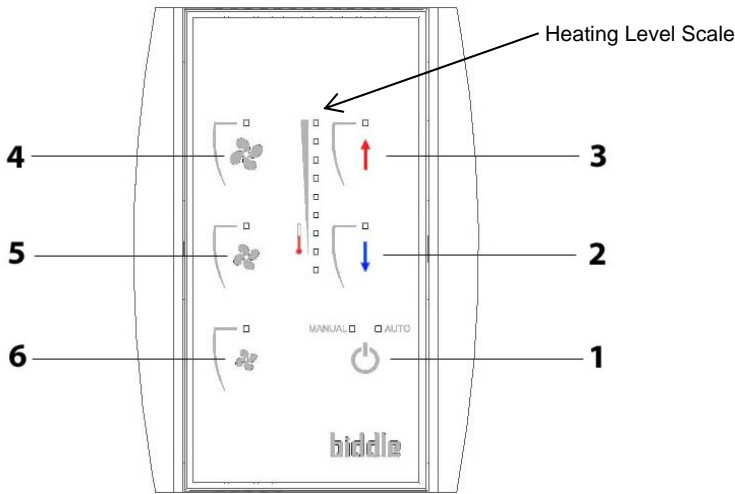

### On/Off – Manual – Auto

Press On/Off switch (1) to switch the air curtain On/Off and cycle between Manual and Automatic modes.

With On/Off switch pressed once, the air curtain is switched on in Manual mode with the 'MANUAL' LED illuminated.

Press On/Off switch again to select Automatic mode, the 'AUTO' LED is now illuminated.

Pressing the On/Off switch again switches the air curtain off with all the LED's switched off. If an electric heated air curtain is heating when switched off the fan will run-on at low fan speed for an extended time (approx. 2 minutes) to dissipate excess heat.

### Heating Control

Heating levels are selected by stepping up or down with switches (2) and (3).

**Manual mode:** heat output can be selected as Zero, Half Heat or Full Heat.

**Automatic mode:** the set point is selected as indicated by the LED's on the heating level scale, the air curtain measures the incoming air temperature and automatically selects the necessary amount of heat to keep it at the level selected. Heating level indicator LED's go from 0% to 100% in nine steps to show the heating level selected. At 0% heat (Ambient) the bottom LED on the scale is illuminated blue.

### Fan Speed

Switches (4), (5) and (6) select fan speed high, medium or low respectively. The appropriate LED above each fan speed indicator is illuminated to show which fan speed is selected.

### DIP Switch Settings

At the back of the remote control PCB there are four DIP switches (see above) that provide the following optional features. The default settings will be all OFF.

DIP1(ON)	<b>Restart on Power-Up</b> – If electrical supply to the air curtain is interrupted, upon restoring electrical supply, the customer's settings on the remote control will be retained, i.e. when electrical supply is restored, unit retains previous controller settings.
DIP2(ON)	<b>Stop Fan on Cold</b> – Fans switch off when heating level is achieved (Automatic mode only).
DIP3(ON)	<b>Never Blow Cold</b> – Unit always heats in Automatic mode (i.e. will not go to ambient mode).
DIP4(ON)	<b>Single Set Point</b> – Heat level setting is shown as one LED, not progressive scale.

**Note:** If the mains electrical supply is isolated or cuts-out during operation the safety thermal cut-out(s) in an electric heated air curtain may operate. If this happens it will need to be reset by a competent technician.

## 3.2 Tailoring the System

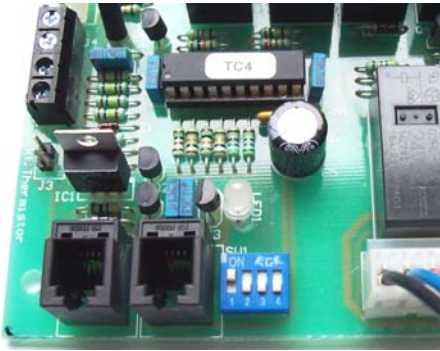

DIP switches fitted on the main motherboard inside the air curtain provide a selection of optional features as described below. Always isolate and switch electrical power off before configuring and/or changing any DIP switch settings.

Function	Control	Comments	As Supplied
<p><b>Fan Heat Interlock for Electric Heated Air Curtains</b> – The heat output is governed by the fan speed. If low or medium fan speed is selected then the heat output will operate on only first heat stage. Second stage heating will only operate on high fan speed.</p>	<p><b>DIP1</b></p>	<p>Second stage heating will only operate on high fan speed. Independently set-up DIP switch on each mother board.</p> <p>Used to avoid excessive temperatures with electric heated air curtains on lower speeds.</p>	<p>For electric heated air curtains the default setting for heat output would be dependent on fan speed (<b>DIP1 ON</b>).</p> <p>For Ambient and LPHW heated air curtains default setting for (<b>DIP1 OFF</b>).</p>
<p><b>Disable Fan Run-on for LPHW and Ambient Air Curtains</b> – Standard run-on time for units is two minutes.</p>	<p><b>DIP2</b></p>	<p>Must only be used for LPHW and Ambient air curtains. Independently set-up DIP switch on each mother board.</p>	<p>For Ambient and LPHW heated air curtains the default setting disables fan run-on (<b>DIP2 ON</b>).</p>
<p><b>Master/Slave Sensor</b> – Only the air sensor thermistor in the master air curtain will be used for measuring the reference air temperature for the whole master/slave installation.</p> <p><b>Global Switching</b> – This DIP switch setting must also be used for Global Switching (Master/Slave) via the INHIBIT terminal – see next page.</p>	<p><b>DIP3 Option</b></p>	<p>With DIP3 on master unit set to ON the air sensor in all the slave air curtains will be ignored. This avoids situations with master/slave air curtains, where it would be possible that some units can blow cold whilst others can blow warm air.</p> <p>The master air curtain need not be the one that the wall control is plugged into.</p>	<p>The default setting would be for all individual air sensors to be measuring independently (<b>DIP3 OFF</b>).</p>
<p><b>Overheat Fan Disable</b> – If DIP4 is off and thermal cut-out(s) operate, only the heating circuit is isolated and the MANUAL LED on the controller flashes RED. If DIP4 is on and thermal cut-out(s) operate, both heat and fan circuits are isolated and MANUAL LED flashes RED.</p>	<p><b>DIP4 Option</b> (Electric only)</p>	<p>Independently set-up DIP switch on each mother board.</p>	<p>The default setting would only disable electric heating if thermal cut-out(s) operate (<b>DIP4 OFF</b>).</p>

□ - white rectangle indicates the moveable head of each 4 way DIP switch

### 3.3 External Controls

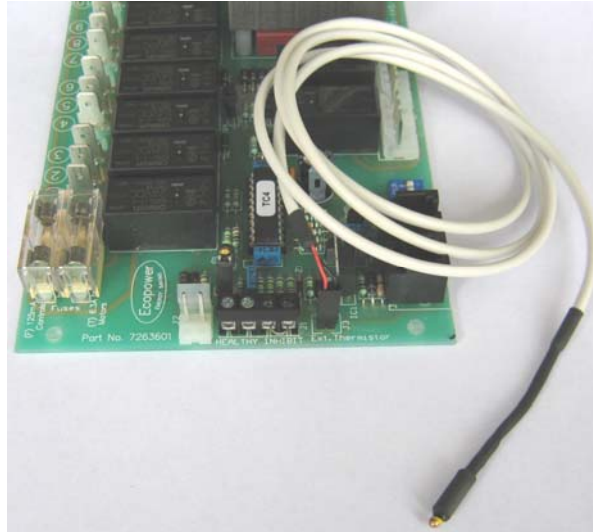

#### Unit ON/OFF

An **INHIBIT** two-way screw terminal is fitted on the motherboard for BMS remote On/Off switching. If the terminal is linked, i.e. by 2 wires to a remote volt free contact, the unit will run. If it is open circuit across the terminal the unit will switch off. This remote On/Off feature has global switching logic, i.e. if you master/slave several units together you need to connect the remote contact to only one of them to turn all units on and off in the master/slave system. For global switching to work, it is necessary to set DIP3 Option (see previous page) on the unit that the remote contact is wired to (Master unit). As supplied, a wire link will be fitted to the INHIBIT terminal block on every unit.

#### Heating ON/OFF

For fan only operation (i.e. heating On/Off) place a 3.3kΩ (R/S part number 148-629) resistance across the **INHIBIT** terminal.

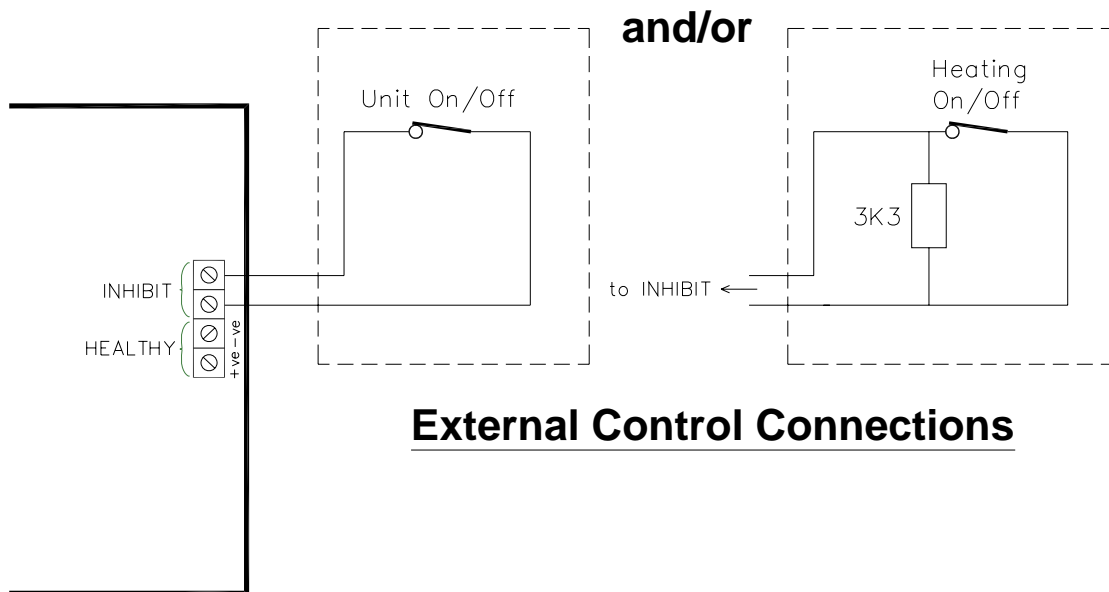

#### Fault Output (Electric Heated Air Curtains Only)

A **HEALTHY** two-way screw terminal is included on the board for a fault signal indication if the electric elements overheat cut-out has operated. A healthy system provides a 24V DC signal at the terminals compared to an overheat fault which provides 0V DC.

## 3.4 Multiple Installation

To Master/Slave two or more air curtains together, or if there are two air curtains in a vertical stack, the remote control is plugged into the first unit (the Master) and a RJ extension lead then connected from the Master to the Slave unit(s).

For horizontal and vertical Master/Slave configuration an independent mains supply as per Table 1 must be supplied to each air curtain. NB The electrical supply to the top air curtain may be routed via the bottom air curtain. Horizontal application air curtains, up to a maximum of eight units, may be connected as indicated below. 3m RJ extension leads are available and should be ordered separately. They are supplied as standard with vertical stack units.

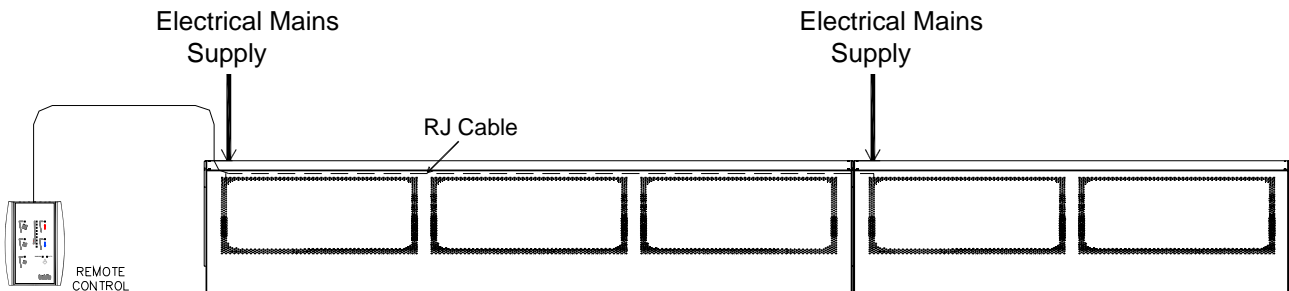

## 4 Commissioning

With the casing **still removed** check the air curtain fans operate correctly and there is no excessive mechanical noise. Check that the fans operate correctly at Low, Medium and High speeds and that the performance/throw of the airstream across the doorway is adequate. If it is not adjust the fan speed voltage(s) accordingly (refer to 4.1 overleaf). If the unit is electrically heated or water heated check that the air stream from the discharge grille warms up across the whole length of the air curtain when heating is selected. Also check that heating increases as higher heat level is selected and feel to see that the warm air stream is reaching across the doorway.

Verify the operation of the Style remote control in Manual Mode. Then select Auto Mode and increase the heating set point until the air stream warms up. Reduce the heating set point until the airstream goes cold. Once all functional tests have been carried out and the air curtain operates satisfactorily, hook and locate the inlet casing in between its fixing tabs ensuring all fixing holes are correctly aligned with tab inserts. Secure panel using the casing screws supplied.

Before leaving site it is important that the air curtain installation is “Handed Over” to the end user or his representative and the operation of it is fully explained and that they understand how it operates. Explain also the service intervals and that the unit must be regularly cleaned.

## 4.1 Transformer Speed Controller

The transformer speed controller fitted to each Style air curtain provides adjustable fan speed control (see below). The transformer tapping output voltages are factory set to three suitable voltages for high, medium and low fan speeds. For 2m air curtains both transformers are connected. For 1m and 1.5m units only one transformer is connected. If fan speed voltage adjustment is required for any of the speeds, move the appropriate fan speed voltage cable (Black – High Speed wire, Blue – Medium Speed wire and Red – Low Speed wire) to a different transformer voltage tapping.

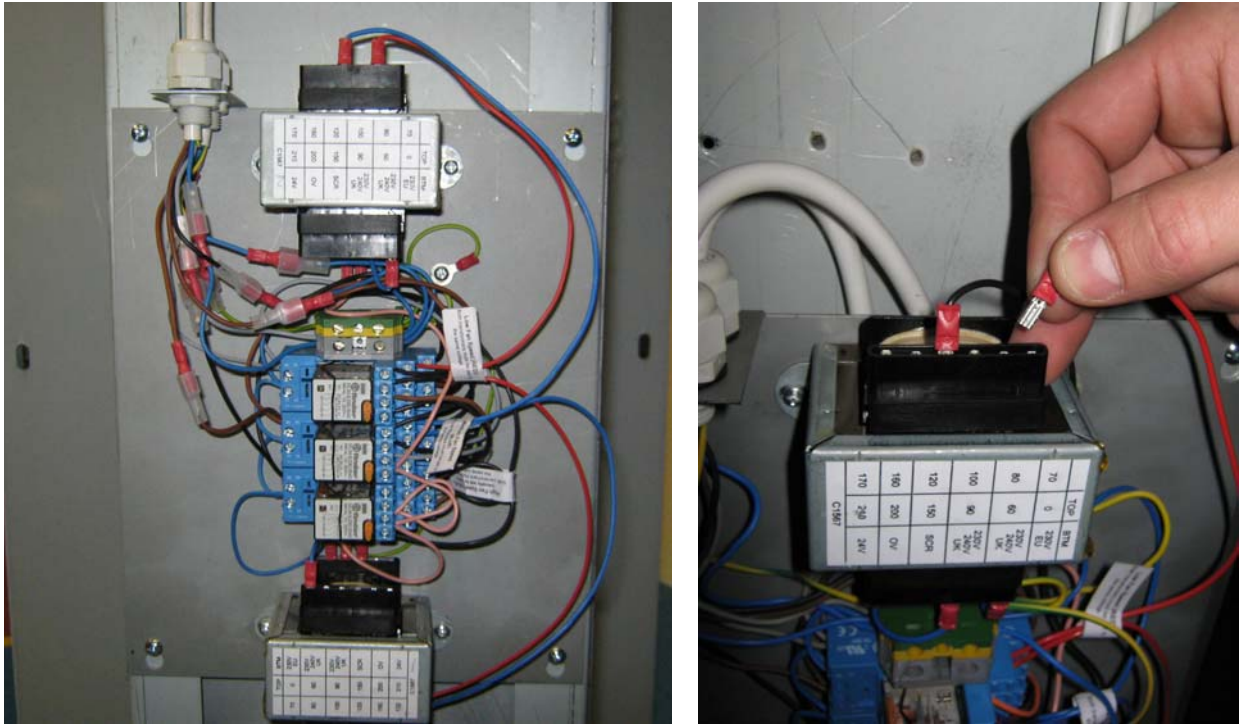

The Black, Blue and Red wires for the fan speeds **must be** connected to the same voltage tappings on both transformers i.e. if the Blue medium speed wire is connected to 100V tapping on one transformer it must be connected to the 100V tapping on the other transformer.

## 4.2 PCB Status

Fitted on the main motherboard inside of the air curtain is an LED, shown as LED1 on wiring diagrams, that will indicate the system control status.



1. LED flashing green – operation normal.
2. LED flashing red – low supply voltage.
3. LED permanently red – thermal cut outs open circuit (electric heated models only).

LED1

# 5 Fault Conditions

In the event of a fault with electrical heated air curtains the thermal cut out(s) may operate.

**Note:** *If the mains supply is isolated during operation then the thermal cut outs may also operate.* The thermal cut out(s) are located within the unit adjacent to the electric elements (one on the 1m & 1.5m and two on the 2m model), the position of each thermal cut-out is marked as per the photo opposite. There are two fuses on the motherboard which may blow in the event of a fault. For horizontal mounted air curtains the motherboard is located on the left hand side (when viewed from inside the building) and towards the top of each air curtain on vertical mounted units.



In the case of a fault condition (refer to flowchart overleaf) do not attempt to reset the thermal cut outs or replace the fuses. Arrange for a Biddle appointed technician or certified electrician to attend the unit to investigate the reason why the thermal cut outs/fuse(s) have operated. Once the cause has been determined and rectified, they will reset/replace the thermal cut out/fuse and function test the unit.

# 5.1 User Fault Finding Flowchart

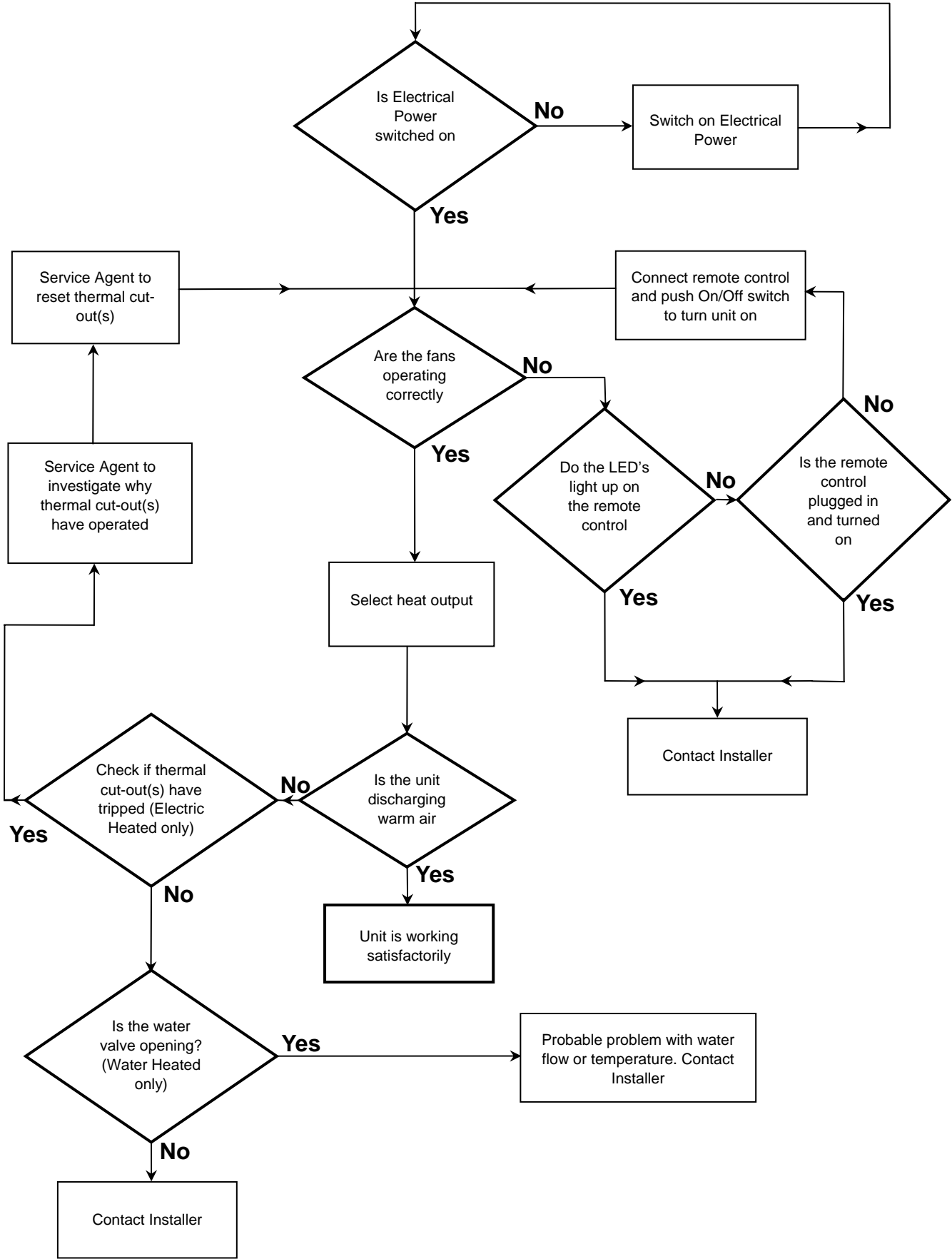

# 6 Service & Maintenance

**Always disconnect and isolate the mains electrical supply before installing, maintaining or repairing this equipment. With 2.5m or 3m vertical air curtains there are two air curtains, one stacked on top of the other. Isolate the mains supply to both top and bottom air curtains. Note: All maintenance/repairs should only be carried out by a competent electrician or Biddle appointed technician.**

To ensure the air curtain operates at full efficiency the back casing and inlet casing panel, fan impellers, housings and motors must be kept free of dust and debris. Build up of dust on the fan impellers can cause vibration, noise and excessive wear on the motor bearings.

Frequency of cleaning will depend on the environment, but we would recommend that the unit be cleaned a minimum of every 3 months (failure to adequately maintain the unit and provide a suitable cleaning schedule will result in performance degradation and reduce the life expectancy of the air-curtain).

Remove the inlet casing panels from the air curtain. Vacuum and clean the build-up of dirt and debris within the air-curtain (*please note that the motor(s) are permanently lubricated and require no additional lubrication*).

If the outer casing requires cleaning this should be done using a warm soft cloth. Do not use solvents or abrasive materials.