

Manual

BEM module

Model BEM

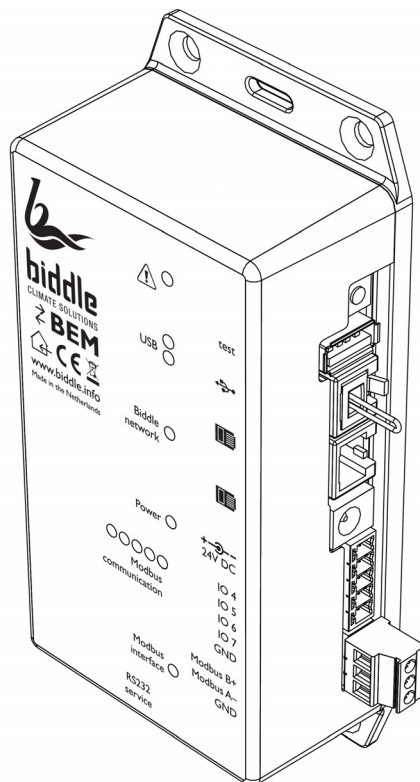

Version 1.1
Original Manual

English



biddle

. . . Contents

1	Introduction	4
	1.1 About this manual	4
	1.2 Required basic knowledge	4
	1.3 How to read this manual	4
	1.4 About the BEM module	5
2	Installation	7
	2.1 Connections to the BEM module	7
	2.2 Meaning of the LEDs	8
	2.3 Installing the BEM module	9
	2.4 Connecting the BEM module to an air curtain.	10
	2.5 Connecting power supply (optional)	10
	2.6 Connecting the BEM module to a Modbus system.	11
3	Operation	12
	3.1 The test button	12
	3.2 The test function	13
	3.3 Outdoor temperature sensor	14
	3.4 The Filter Sensor	18
	3.5 Software update via USB	19
4	Basic Modbus Actions	20
	4.1 Modbus settings	22
5	RS232 Service	24
	5.1 Introduction	24
	5.2 Connecting to the BEM module	24
	5.3 Serial interface commands	24
6	Setting Menu Parameters	28
	6.1 Configuring via Modbus	28
	6.2 Entering via RS232 Service connection	28
	6.3 Configuring via USB	29
	6.4 Overview of menu parameters	30
7	Menu parameters	34
	7.1 Introduction	34
	7.2 Switching the air curtain on and off	34
	7.3 Manual setting of the strength	36
	7.4 Adjust the automatic strength control	36
	7.5 Controlling the temperature	36
	7.6 Automatic or manual control	37

8	Other Modbus addresses	53
8.1	Register types	55
9	Log Files	56
9.1	Log_error.csv	57
9.2	Log_func.csv	57
9.3	Log_stat.csv	58
9.4	Log_user.csv	58
10	Faults	60
10.1	Resolving simple problems	60
10.2	Reading out faults	61
10.3	Deleting faults	62

1. Introduction

1.1 About this manual

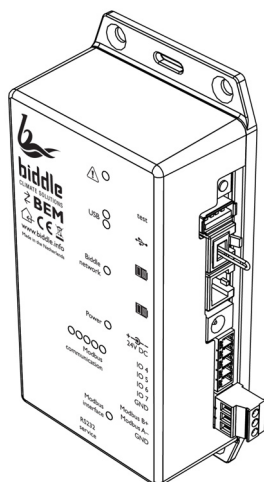

This manual describes the installation and use of the BEM module in combination with the CA₂ comfort air curtain.

1.2 Required basic knowledge

To use this manual, you must have general knowledge of the Modbus RTU protocol. This manual is not a guide to this protocol. For more information about Modbus, see the specifications and guidelines available on the website of the Modbus Organization: www.modbus.org.

1.3 How to read this manual

1.3.1 Symbols in the manual

The following symbols are used in the manual:



Note:

Draws your attention to an item of special importance.



Caution:

Failure to carry out the procedure or action correctly can result in damage to the unit.

Follow the instructions to the letter.

**Warning:**

Failure to carry out the procedure or action correctly can result in damage and/or physical injury.

Follow the instructions to the letter.

**Danger:**

Used for actions that are not permitted.

Ignoring this ban can lead to serious damage or accidents resulting in bodily injury.

1.3.2 Related documents

As well as this manual, you need the manual for the Biddle CA₂ comfort air curtain.

1.4 About the BEM module

1.4.1 Application

The BEM module is designed for use with the Biddle CA₂ comfort air curtain and replaces the b-touch control panel. When using a BEM module, air curtain is controlled via RS485 Modbus RTU protocol.

For servicing purposes, a computer can be connected via a serial RS232 interface.

1.4.2 Supported Modbus functions

The BEM module supports two standard Modbus functions:

FUNCTION CODE	FUNCTION NAME	METHOD
3	Read Holding Registers	read (r)
6	Preset Single Register	write (w)

I.4.3 Type plate



The type plate is located above the RS232 service terminal.

I.4.4 Field of application

The BEM module is designed for indoor use in commercial spaces with an ambient temperature from 5°C to 40°C.

2 . . Installation

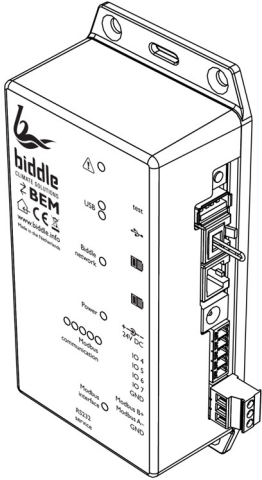
2.1 Connections to the BEM module

	DESIGNATION	DESCRIPTION
	test	Test button
		USB connection
		Biddle communication
	24V DC	Power supply (optional)
	IO4..7/GND	No function
	Modbus B+	RS485 communication: signal B (+)
	Modbus A-	RS485 communication: signal A (-)
	GND	RS485 communication: earth
	RS232 service	Standard RS-232 connection for diagnosis and software updates.

See also:

- 3.1 "The test button" on page 12
- 3.2 "The test function" on page 13

2.2 Meaning of the LEDs

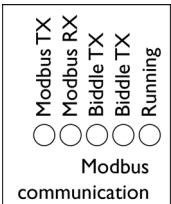
LED	COLOUR	ON	FLASHING	OFF
⚠	Red	Fault	Flashing continuously: Test mode	No fault
			1x: receive temperature from wireless sensor 1	
			2x: receive temperature from wireless sensor 2	
			3x: wireless sensor found in learning mode	
USB with connected USB stick	Red	Fault	Software update	Both off: no USB stick connected
	Green	Ready	Busy	
USB in test mode, without USB stick	Red	Test mode 1	Test mode 3	Test mode 2
Biddle network	Green	Communication OK	Communication fault	No communication
			Microswitch on the unit's printed circuit board pressed in.	
Power	Green	Power supply connected	-	No power supply
Modbus communication 	Red	-	Modbus TX	No communication
	Green	-	Modbus RX	No communication
	Red	-	Biddle TX	No communication
	Green	-	Biddle RX	No communication
	Yellow	-	Active	No communication
Modbus interface	Green	Communication between Modbus and Biddle network OK	Communication error: LED flashes for invalid parameters or values entered using 'SETBEMS' command.	No communication: LED turns OFF if no valid command has been processed for at least one minute.

See also:

3.2 "The test function" on page 13

3.1 "The test button" on page 12

- 3.3.2 "Connecting the TS2 wireless sensors and RSR receiver module to the BEM module (optional)" on page 15
- 3.5 "Software update via USB" on page 19

2.3 Installing the BEM module

2.3.1 Special Points regarding the BEM Module

Cabling



Caution:

Take the following into account, otherwise faults may occur:

- The control cable between the BEM module and the (first) connected unit must not be more than 50 m long. If a greater length is required, you can connect an external power supply to the BEM module.
- Keep control cables away from electromagnetic fields and interference sources such as high-voltage cables and fluorescent light starters.
- Lay control cables out straight or roll them bifilarly by folding cables in half before rolling them. This significantly reduces inductance.
- Do not remove the dummy plug, unless otherwise stated.



Caution:

Use Biddle control cables only.

Standard modular telephone cable is NOT suitable.

- Up to 10 units can be connected to a single BEM module. To do so, the units must be interlinked. Readings can be taken from a maximum of 4 units.



Note:

The RSR receiver counts as one unit.

- The total length of the control cables is not to exceed 100 m.
- Only units that have the same second digit in the unit code (see "Code" on the type plate) can be controlled in combination with the same BEM module.

- If multiple units are connected to the BEM module, its settings will be the same for all units.

**Note:**

To control units differently, you need multiple BEM modules. In that case, you have to set an individual Modbus address on each module.

See also:

4.1.1 "Changing the Modbus Address" on page 22

2.4 Connecting the BEM module to an air curtain.

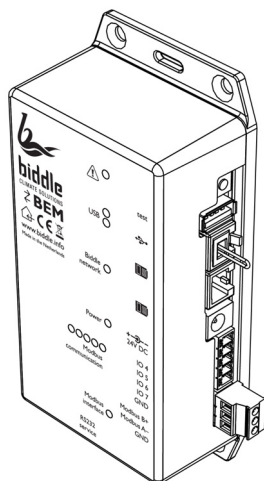
**Warning:**

The BEM module replaces the b-touch control panel. It is not possible to have them both connected to an air curtain at the same time.

1. Connect the control cable to the free terminal  on the BEM module.

**Caution:**

You should only remove the dummy plug from the other terminal if a unit or an RSR receiver module is to be connected to it, otherwise faults may occur.

2.5 Connecting power supply (optional)

In normal situations, the BEM module is powered by the Biddle communication network. If long control cables are used or if there is additional power consumption, a separate 24V DC power supply can be connected to the BEM module. The components for this are not supplied.

2.6 Connecting the BEM module to a Modbus system.

2.6.1 Wiring

A twisted-pair cable must be used for connection to the Modbus system. The cable must also have a third core for the earthing. If shielded cables are used, the shielding must not be used as an earth connection. Normally, a four-pole, twisted-pair cable is used; one pair is used for communication and one core from the other pair is used as the earth connection.

Shielded cable

Shielded cables are only required in situations where there is a lot of electromagnetic interference, such as industrial environments. The communication itself can also emit interference that must be shielded. Normally, this applies only to high data speeds.

When shielded cables are used, the shielding of each cable must be connected at one end to the "GND" terminal.

Modbus A = -

Modbus B = +

GND = ground

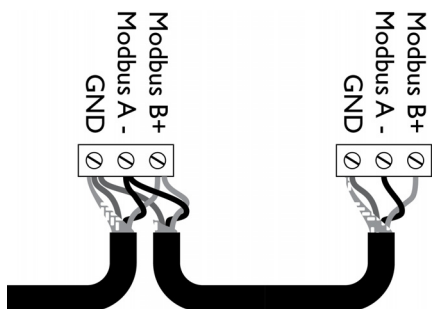

Note: Incorrectly connected wiring may be possible cause of no communication. Swap A- and B+ wires.

3. . Operation

3.1 The test button

The test button can be used to activate a variety of functions:

FUNCTION	ACTION	DESCRIPTION
Test function	Press test button briefly for the 1 st time	The unit runs for 30 minutes at fan speed 1 with a maximum air discharge temperature of 50°C.
	Press test button briefly for the 2 nd time	The unit switches off for 30 minutes
	Press test button briefly for the 3 rd time	The unit runs for 30 minutes at fan speed 1 without heating.
	Press test button briefly for the 4 th time	The unit runs for 30 minutes at fan speed 6 with heating.
	Press test button briefly for the 5 th time	End test function
Deleting faults	Press test button for 3 seconds	The fault is deleted and a new search for connected units is initiated.
Restore default settings	Press test button when switching on the power supply until the LEDs at  , Biddle network and modbus interface start to flash.	All menu settings are reset to the default settings and a new search for connected units is initiated.
Download log files and settings, upload settings	<ul style="list-style-type: none"> Connect a USB stick to the BEM module. Press the test button briefly. 	The green USB LED flashes rapidly while the log files are being written and while the configuration file (if available) is being read.
Update software	<ul style="list-style-type: none"> Connect a USB stick to the BEM module. Press test button for three seconds until red LED begins to flash. 	The green USB LED will flash rapidly while the new software is being installed.

3.2 The test function

To check the operation of the unit, you can use the test function. With this, the unit runs for a certain length of time at a fixed setting, independently of the controls. The remaining time counts down to zero and then normal operation is resumed. You can use the Modbus readings or the 'BEMS' command to check the operation while the test function is running.



Note:

When the test button is activated, the unit runs in test mode for 30 minutes. When activated via Modbus or RS232, you can set the duration.

Test modes

TEST MODE	DESCRIPTION	RED USB LED	FAN SPEED	HEATING
0	Normal use	Off	Automatic	automatic
1	Heating	ON	1 or 3	On (maximum discharge temperature 50°C)
2	Unit off	Off	0	Off
3	Without heating	Flashing	1 or 3	Off
4	With heating	Off	6	On (maximum discharge temperature 50°C)

Activating the test modes and additional actions

TEST MODE	TEST BUTTON	MODBUS ADDRESS	MODBUS VALUE	RS232
0	-	10101	0	Testmode <sec> 0
1	1x short	10101	1	Testmode <sec> 1
2	2x short	10101	2	Testmode <sec> 2
3	3x short	10101	3	Testmode <sec> 3
4	4x short	10101	4	Testmode <sec> 4
Set duration	-	10102	<sec>	Testmode <sec>
Read remaining time	-	10102	-	Testmode
Interrupt test mode	4x short	10101	0	Testmode 0 0

3.2.1 Test input

The functioning of the input signal can be tested in test modes 1 and 3:

INPUT IIII	FAN SPEED
Contact broken	1
Contact closed	3

This fan speed in the test mode is independent of the set function of the input.

3.3 Outdoor temperature sensor

The automatic CHIPS control requires an outdoor temperature in order to operate correctly. To enter this temperature, use one of the following four options:

1. A wired outdoor sensor (standard);
2. A TS2 wireless outdoor sensor and RSR receiver module (optional);
3. A pipe sensor (optional);
4. Setting the outdoor temperature via Modbus.

It is possible to have several options set simultaneously. For this purpose, the control system uses the following order of priority:

1. Outdoor temperature via Modbus;
2. TS2 wireless outdoor sensor;
3. Wired outdoor sensor/pipe sensor.

If the control system does not receive any of the above temperatures, the value of Modbus address [179]/menu parameter TJAN is used as the outdoor temperature.

3.3.1 Setting the wired outdoor sensor

To install the wired outdoor sensor, read the manual for the CA₂ comfort air curtain.

ACTION	MODBUS ADDRESS	VALUE	RS232
Activating the wired outdoor sensor	159	0 (default)	Menu 59 0
Deactivate any wireless sensors	187	0 (default)	Menu 87 0

3.3.2 Connecting the TS2 wireless sensors and RSR receiver module to the BEM module (optional)

To connect the TS2 wireless sensors and the RSR receiver module, read the manual for the CA₂ comfort air curtain.

Connecting the sensors

Two wireless sensors can be connected to the RSR: one outdoor temperature sensor and one indoor temperature sensor. The table below shows how the learning mode is activated.



Note:

Sensors cannot be linked via Modbus commands.

Hold the wireless sensor and the RSR receiver module close to each other while connecting the sensors. When the microswitch on the sensor is pressed, the sensor will transmit a temperature every 10 seconds for about 20 minutes. Use this time to mount the sensor in its place. Reception can be checked by the flashing of the LED on the BEM module.

1. Activate the learning mode:

SENSOR	RSR MODULE	RS232
Outdoor sensor	Press red button 1x	learn 0
Indoor sensor	Press red button 2x	learn 1
	Pressing once more toggles back to the outdoor sensor and so on.	

The  LED on the BEM flashes every second in the learning mode: 1 short flash for the outdoor sensor and 2 short flashes for the indoor sensor.

2. Press the microswitch of the temperature sensor.

When the sensor has been found, the  LED on the BEM module flashes three times. The sensor is then also activated immediately in the control system. The addresses of the sensors are stored in the memory of the RSR receiver module. This means that they stay saved when the BEM module's factory settings are restored, although the sensors do have to be activated again.

The learning mode is terminated when a sensor is found or 5 minutes after the button on the RSR receiver module was last pressed.

When receiving a temperature from the outdoor sensor or the indoor sensor, the  LED on the BEM module flashes once or twice respectively.

Activating the sensors

After the BEM modules have been restored to factory settings, connected sensors must be reactivated.

SENSOR	MODBUS ADDRESS	VALUE	RS232
No sensor	187	0	Menu 87 0
Outdoor sensor only	187	1	Menu 87 1
Indoor sensor only	187	2	Menu 87 2
Both sensors	187	3	Menu 87 3



Caution:

Activating an unconnected sensor results in error message F9 or F10. This error message is given after about 25 minutes.

3.3.3 Setting the pipe sensor (optional)

To connect the pipe sensor, read the manual for the CA₂ comfort air curtain.

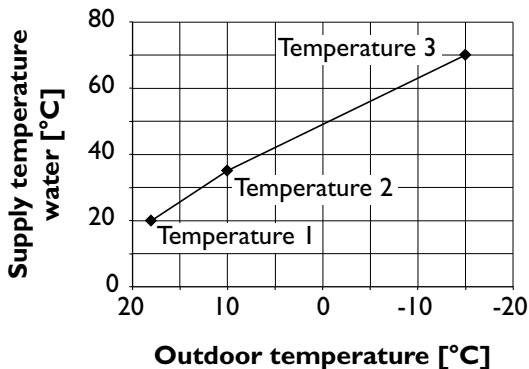

The pipe sensor can be used instead of the outdoor sensor to get weather-responsive control of the water temperature. The outdoor temperature is then deduced from the input temperature of the water, based on the 'heating line'. This heating line must be entered using menu parameters.



Note:
Temperature should be entered to one decimal point (0.1 °C).

ACTION	MODBUS ADDRESS	VALUE	RS232
Activating the pipe sensor	159	1	Menu 59 1
Point 1 – Temperature of pipe sensor <t1.s>	149	<t1.s>	Menu T1.S <t1.s>
Point 1 – Outdoor temperature <t1.o>	168	<t1.o>	Menu T1.O <t1.o>
Point 2 – Temperature of pipe sensor <t2.s>	170	<t1.s>	Menu T2.S <t2.s>
Point 2 – Outdoor temperature <t2.o>	173	<t3.o>	Menu T2.O <t2.o>
Point 3 – Temperature of pipe sensor <t3.s>	174	<t3.s>	Menu T3.S <t3.s>
Point 3 – Outdoor temperature <t3.o>	175	<t3.o>	Menu T3.O <t.o>

3.3.4 Setting the outdoor temperature via Modbus (optional)

To operate correctly, the automatic controls need an outdoor temperature. This can be entered via Modbus and RS232, removing the need for a separate outdoor temperature sensor.

With this entry, the currently measured outdoor temperature is overwritten. Repeat this within fifteen minutes, otherwise this value will be overwritten by current measured temperature. The response is the temperature that will be used by the controls.

This command will not be executed if there is an E2 fault (faulty connection).

ACTION	MODBUS ADDRESS	VALUE	RS232
Current outdoor temperature entry T_{out} in 0.1 °C	10120	T_{out}	TCurrenttout < T_{out} >

3.4 The Filter Sensor

If the unit is fitted with a filter sensor, the filter contamination can be measured.



Note:

A filter sensor needs to have been registered in order to be able to measure filter clogging. This can be registered by writing the value '2' to Modbus address [605]..

ACTION	MODBUS ADDRESS	MODBUS VALUE	RS232
Read out filter contamination as %	10110	-	Testfilt
Filter contamination measurement or calibration active (0=inactive; 1=active)	10111	-	Testfilt
Measure filter contamination	10112	1	Testfilt 1
Calibrate filter sensor	10112	2	Testfilt 2

The command “**TESTFILT**” is only valid if the unit is fitted with a filter sensor. The measurement and calibration cannot be interrupted.

3.4.1 Measure filter contamination

The filter contamination is measured by running the fans at top speed for 40 seconds. The filter contamination is displayed as a percentage.

3.4.2 Calibrate filter sensor

The base level of the filter sensor is determined by calibrating the sensor. This involves the unit running for some time at the highest fan setting. The sensor should, for example, be calibrated after installing a built-in unit.

The calibration value is written in menu parameter *.CL and Modbus address [100], [133], [136] or [139], depending on the type of unit - S, M, L, XL.



Caution:

Only use this function with clean filters. Calibrating with dirty filters will give false values and negatively affect the measurement of filter contamination.

3.5 Software update via USB

Biddle is working continuously on improving its products and recommends that you update the software of the BEM module when updates become available. Check the Biddle website for availability.

1. Download the software from the Biddle website
2. Rename the file “bidbem.uimage” and copy it to the root of a USB flash drive
3. Connect the USB flash drive to the BEM module. The green USB LED will flash slowly.
4. Press test button for three seconds until red LED begins to flash. The green USB LED will flash rapidly while the new software is being installed.
5. The BEM module will restart after installation. At this point, all the LEDs on the module will flash for a short time.
6. Disconnect the USB flash drive from the BEM module.



Note:

If the software on the USB flash drive is identical to the software in the module, the update will not be executed.

4. . Basic Modbus Actions

ACTION	ADDRESS	VALUE & DESCRIPTION
Modbus settings		
Change Modbus address	1 6	Address 1
Adjust baud rate	4	0 = 9600 1 = 19200 2 = 38400 3 = 57600 4 = 115200 255 = Not set; the default value (9600) is used
Adjust endianness	2	0 = big endian 1 = little endian
Restart the Modbus interface	6	1 = restart the Modbus interface
Restart the BEM module	198	1 = restart the BEM module
Configure unit		
Set door height	182	<door height in cm> The door height is the distance from the floor to the under-side of the outlet grille.
Connect and test sensors		
• Door switch	160	<function input>
• Outdoor temperature sensor	159	0 = outdoor temperature sensor 1 = contact sensor (149, 168, 170, 173, 174, 175)
• IR sensor	186	0-7
Program inputs and outputs		
• Input	160	<function input>
• Output 1	161	<function output>
• Output 2	147	<function output>
Operate unit		
Unit on/off	10000	0 = unit off 1 = unit on
Regulate strength		
• Automatically or via Modbus	10002	0 = via Modbus 1 = automatically
• Automatic - strength adjustment	10004	-3...+3
• Fan strength via Modbus	10003	1...6

ACTION	ADDRESS	VALUE & DESCRIPTION
Room temperature		
• Set default value	105	<default temperature in 0.1°C>
• Temporarily adjust temperature	10005	<desired temperature in 0.1°C> When the unit is switched on again, the desired room temperature is reset to the value of address [5]
Heating on/off	10001	0 = heating off 1 = heating on
Enter current outdoor temperature	10120	<outdoor temperature in 0.1°C> This value has to be repeated within 15 minutes.
Read out usage data (read only)		
Fan speed	904	Fan speed of connected units. Depending on the function of the input, a unit may have a different fan speed.
Air inflow temperature	10050	Average air inflow temperature at the connected units in 0.1°C
Discharge air temperature	10051	Average air discharge temperature from the connected units in 0.1°C
Outdoor temperature	10053	Outdoor temperature, average for 3-minute period in 0.1°C
Maintenance		
Reading out faults		
• Fault register 1	10055	See fault codes
• Fault register 2	10059	See fault codes
• Deleting faults	198	1
Filter		
• Calibrate	10112	2
• Measure contamination	10112	1
Test mode	10101	See test mode

See also:

- 7 "Menu parameters" on page 34
- 10 "Faults" on page 60
- 3.4 "The Filter Sensor" on page 18
- 3.2 "The test function" on page 13

4.1 Modbus settings

4.1.1 Changing the Modbus Address

The default Modbus address for the BEM module is 240. Depending on the Modbus network, it may be necessary to change this.



Caution:

If multiple BEM modules are used in one Modbus network, each module must be assigned its own address.

1. Write the desired Modbus address in the address register [1]
2. Read the address register [1] and check the value is correct.
3. Restart the BEM module by switching the power supply off and on or via a software-based reset by writing the value "1" in the command register [6].

4.1.2 Changing the baud rate

The default baud rate of the BEM module for Modbus communication is 9600 baud.

1. Write the baud rate setting in the baud rate register [4] in accordance with the table below.

BAUD RATE SETTING	BAUD RATE
0	9600
1	19200
2	38400
3	57600
4	115200
255	Not set; the default value (9600) is used

2. Read the baud rate register [4] and check whether the value is correct.
3. Restart the BEM module by switching the power supply off and on or via a software-based reset by writing the value "1" in the command register [6].

4.1.3 Changing the endianness

Endianness is the sequence in which the response is returned when reading out multiple registers simultaneously via the BEM module. By default, this is the “little endian” in line with the Modbus standard. If desired, this can be changed to “big endian”.

1. Write the desired value for the endianness in the endianness register [2].
2. Read the address register [2] and check the value is correct.

ENDIANNESS	REGISTER VALUE	DESCRIPTION
little-endian	1	Response address in ascending order: 0..n (Modbus standard)
big-endian	0	Response address in descending order: n..0

5. . RS232 Service

5.1 Introduction

You can connect a computer to the BEM module to check and adjust the operation of the connected units. The units can be controlled via terminal software such as “Hyper Terminal”.

5.2 Connecting to the BEM module

1. Connect an RS232 cable from the computer to the RS232 service terminal on the BEM module.
2. Start the terminal software on the computer. Connection parameters: baud rate 115k2, 8 data bits, 1 stop bit, no parity
3. Control the connected units with the relevant serial interface commands.

5.3 Serial interface commands

5.3.1 Overview

COMMAND	PARAMETERS	DESCRIPTION	RESPONSE
RESET	-	Restart the BEM module	
VER	-	Displays the software version	BEMS Software versie: 0.1-2 (102)
LEARN	[0 1]	Connecting wireless sensors to the RSR module: 0 = wireless outdoor sensor 1 = wireless indoor sensor	Wireless sensor found
CONF	-	Overview of the Biddle communication network	Netwerk configuratie: 1: [HSP] SNR=56667 CC=4111 SW=V1.2 Comm=OK 2: [HSP] SNR=56667 CC=4111 SW=V1.2 Comm=OK ...

COMMAND	PARAMETERS	DESCRIPTION	RESPONSE
MENU		Display the value of all menu parameters.	<par> : <val> ...
MENU	par	Display the value of the parameter.	<val>
MENU	par val	Writes the value <val> into the parameter	<val>
BEMS	-	Reads out current data.	TempAanz=215 TempUitbl=310 TBuiten=140 TbFilt=135 Test- Mode=0 ErrFlags=0 rrFlags2=0 RealHeat=1251 DoorRatio=23 InpICnt=3452 Person=0
SETBEMS		Display current use settings.	On=1 Heat=1 Auto=0 Fan=4 Fan- Offs=-2 Temp=225
SETBEMS	[par val]	Write settings for use.	
TESTMODE	[sec [mode]]	Test function.	-
TESTFILT	[1 2]	1 = measure filter contamination. 2 = calibrate filter sensor.	FilterPct=<%> Busy
CURRENTTOUT	T _{out}	Current outdoor temperature input.	<T _{out} >
SETCONF	code	Set unit code.	OK

5.3.2 CONF

The command “CONF” displays an overview of the Biddle communication network and the connected components. The response consists of a number of components:

DESIGNATION	DESCRIPTION
X:	Serial number
[...]	Type of module: <ul style="list-style-type: none"> [HSP] = printed circuit board [RFM] = RSR receiver module [UNKNOWN] = unknown
SNR	Serial number of the printed circuit board
CC	Unit code
SW	Software version of the printed circuit board
Comm	Status of communication with the BEM module

5.3.3 MENU

The air curtain settings can be changed with the “MENU” command, combined with a menu parameter and a value.

When combined only with a menu parameter, the “MENU” command displays the set value for that function.

The “MENU” on its own displays the set values for all menu parameters.

Example: “MENU 82 250” sets the door height at 250 cm.

See also:

7 "Menu parameters" on page 34

5.3.4 BEMS

The command “BEMS” reads out current usage data.

DESIGNATION	DESCRIPTION	UNIT
TempAanz	Average air inflow temperature at the connected units	0.1 °C
TempUitbl	Average air discharge temperature from the connected units.	0.1 °C
Tbuiten	Current outdoor temperature	0.1 °C
Tbfil	Filtered outdoor temperature, average for 3-minute period	0.1 °C
Testmode	Indication for test mode	-
ErrFlags	Fault codes 1	-
ErrFlags2	Fault codes 2	-
RealHeat	Current heating capacity	W/m
DoorRatio	Door open/closed ratio, average over the time set in menu parameter 31.5	%
InpICnt	Number of switching actions on the unit's input	-
Person	Number of switching actions on the unit's IR sensor.	-

See also:

3.2 "The test function" on page 13

10.2.2 "Fault Codes Register 10055/Errflags" on page 61

10.2.3 "Fault codes register 10059/Errflags2" on page 62

5.3.5 SETBEMS

The air curtain can be operated with the command “SETBEMS” combined with a parameter and a value. One parameter can be written each time. This means the command has to be used several times when multiple parameters are to be modified.

The command “SETBEMS” with no parameter displays the current parameter settings.

Example: “SETBEMS Temp 230” sets the desired room temperature to 23°C

PARAMETER	DESCRIPTION	VALUE
On	Switching unit ON and OFF	0 = Unit off 1 = Unit on
Heat	Enabling and disabling heating	0 = Heating off 1 = Heating on
Auto	Automatic or manual control	0 = Manual 1 = Automatic
Fan	Fan speed in manual mode	1 – 6
FanOffs	Adjusting automatic strength	-3 - 3
Temp	Desired room temperature in 0.1°C	150 - 400

5.3.6 SETCONF

The command “SETCONF” is used to change the unit code. The unit code depends on the unit type and is indicated on the type plate.

Use the “CONF” command to check whether the unit code has been accepted by the unit’s printed circuit board.



Caution:

Entering the unit code using this method will only work if just one unit is connected to the control panel. If necessary, connect the control panel separately to the unit in question.

Example: “CODE 3513”

6. . Setting Menu Parameters

The operation of the connected air curtains can be configured by writing menu parameters.

6.1 Configuring via Modbus

1. Write the desired value in the relevant address.

It may take up to three minutes before a menu parameter's new value is returned. You can use the writing status of the relevant menu parameter to check at an earlier stage whether the value has been set.

ACTION	How
Check menu parameter	Read the Modbus address
Set menu parameter	Write the desired value in the relevant address.
Check writing status	Read the Modbus writing status: 0 = unknown 1 = not yet written 2 = error 3 = written 4 = read 5 = invalid



Note:

The Modbus addresses from [10000] are intended to be written regularly. The other addresses should only be written when a value is changed.

6.2 Entering via RS232 Service connection

The air curtain settings can be changed with the “MENU” command, combined with a menu parameter and a value.

When combined only with a menu parameter, the “MENU” command displays the set value for that function.

The “MENU” on its own displays the set values for all menu parameters.

Example: “MENU 82 250” sets the door height at 250 cm.

6.3 Configuring via USB

Menu parameters can also be configured using a USB flash drive.

1. Create a text file with the name 'settings.txt' on a computer or rename the downloaded configuration file 'settings_export.txt' as 'settings.txt'.
2. In this file, include the menu parameters that you wish to configure, together with their desired value.



Caution:

The nomenclature of the menu parameters is case-sensitive.



Caution:

Only change the parameters for which a Modbus address is indicated in the table. Leave all other parameters unchanged.



Note:

Only the values in the 'settings.txt' file will be changed. This means the file does not have to contain all the menu parameters.

3. Connect the USB flash drive to the BEM module.
4. Press the test button briefly. The green USB LED flashes rapidly while the log files are being written and while the configuration file is being read.

6.4 Overview of menu parameters

The table below gives an overview of valid menu parameters.

MENU PARAMETER	MODBUS ADDRESS	MODBUS WRITE STATUS	DESCRIPTION	UNITS	MINIMUM VALUE	MAXIMUM VALUE	DEFAULT VALUE	OPTIONS
name	-	-	Settings file name	-	-	-	-	maximum 15 characters
0.1	10000	10010	Air curtain on/off	-	0	2	1	0 = off 1 = on 2 = frost protection mode
0.2	10001	10011	Heating on/off	-	0	1	1	0 = heating off 1 = heating on
0.3	10003	10013	Manual setting of the strength	-	1	6	1	
0.4	10004	10014	Adjust automatic strength	-	-3	3	0	
0.5	10005	10015	Set room temperature	0.1°C	150	400	210	
0.6	10002	10012	Automatic or manual control	-	0	1	1	0 = manual 1 = automatic
1	101	251	Discharge temperature control	-	1	5	5	see explanation
2	102	252	Reset filter	-	0	1	0	1 = reset filter life counter
2.5	125	275	Lapsed filter life	w	0	255	0	
3	103	253	Filter life	w	1	52	13	
3.1			Filter sensor check time	m	0	1439	0	
3.2	124	274	Cleaning interval adjustment	w	-3	3	0	
4	104	254	Track filter life	-	0	1	1	1 = track filter life
5	105	255	Default room temperature	0.1°C	150	300	210	
6	106	256	Minimum air temperature	0.1°C	-100	150	10	
11	111	261	Default settings	-	0	1	0	1 = restore default settings

MENU PARAMETER	MODBUS ADDRESS	MODBUS WRITE STATUS	DESCRIPTION	UNITS	MINIMUM VALUE	MAXIMUM VALUE	DEFAULT VALUE	OPTIONS
13	113	263	Select modes	-	1	3	3	see explanation
30	130	280	Time constant for measuring inlet temperature	min	0	99	1	
31.5	129	279	Time constant for measuring door open/close ratio	min	0	60	6	
54	154	304	Strength with door closed	-	0	4	1	
55	155	305	Temperature difference for boost function	0.1°C	-100	0	-10	
55.5	145	295	Enable boost function	-	0	1	0	1 = enable boost function
56	156	306	Fan speed increment for boost function	-	0	5	0	
56.5	146	296	Relay delay for decreasing fan speed in boost function	s	0	100	0	
58	158	308	Maximum strength	-	3	6	6	
59	159	309	Sensor X82	-	0	1	0	0 = outdoor sensor 1 = pipe sensor
60	160	310	Function of input	-	0	71	0	see explanation
61	161	311	Function output 1	-	1	69	1	see explanation
61b	147	297	Function output 2	-	1	69	1	see explanation
62	162	312	P-factor room temperature control	-	0	99	3	
63	163	313	I-factor room temperature control	-	0	99	50	
64	164	314	D-factor room temperature control	-	0	99	0	
65	165	315	P-factor discharge temperature control	-	0	99	50	
66	166	316	I-factor discharge temperature control	-	0	99	10	

MENU PARAMETER	MODBUS ADDRESS	MODBUS WRITE STATUS	DESCRIPTION	UNITS	MINIMUM VALUE	MAXIMUM VALUE	DEFAULT VALUE	OPTIONS
67	167	317	D-factor discharge temperature control	-	0	99	0	
71	171	321	Factory configuration	-	0	1	0	1 = restore default factory configuration
72	172	322	Error display	-	0	3	1	see explanation
76	176	326	Release delay input	s	0	1000	0	
77	177	327	Valve position when unit is off	-	0	1	0	0 = valve closed 1 = valve open
77.5	148	298	Opening percentage valve when unit is off	%	2	100	5	
78	178	328	Valve position fans off (%)	%	0	100	5	
80	180	330	Fan off temperature	0.1°C	0	100	0	
82	182	332	Installation height	cm	100	500	240	
84	184	334	Heating off temperature	0.1°C	-95	300	180	
86	186	336	IR sensor	-	0	7	0	see explanation
87	187	337	Wireless sensors	-	0	7	0	see explanation
98	198	348	Reset control panel/BEM module	-	0	1	0	1 = reset control panel
S.CL	100	250	Filter - Clean level CA S	Pa	0	7500	51	
S.MN	107	257	Filter - Lower limit CA S	Pa	0	255	12	
S.MX	129	279	Filter - Upper limit CA S	Pa	0	255	26	
M.CL	133	283	Filter - Clean level CA M	Pa	0	7500	101	
M.MN	134	284	Filter - Lower limit CA M	Pa	0	255	14	
M.MX	135	285	Filter - Upper limit CA M	Pa	0	255	42	
L.CL	136	286	Filter - Clean level CA L	Pa	0	7500	120	
L.MN	137	287	Filter - Lower limit CA L	Pa	0	255	23	
L.MX	138	288	Filter - Upper limit CA L	Pa	0	255	63	
X.CL	139	289	Filter - Clean level CA XL	Pa	0	7500	202	

MENU PARAMETER	MODBUS ADDRESS	MODBUS WRITE STATUS	DESCRIPTION	UNITS	MINIMUM VALUE	MAXIMUM VALUE	DEFAULT VALUE	OPTIONS
X.MN	140	290	Filter - Lower limit CA XL	Pa	0	255	36	
X.MX	141	291	Filter - Upper limit CA XL	Pa	0	255	84	
T1.S	149	299	Point 1 pipe sensor temperature	0.1°C	0	1000	200	
T1.O	168	318	Point 1 outdoor temperature	0.1°C	-400	500	180	
T2.S	170	320	Point 2 pipe sensor temperature	0.1°C	0	1000	350	
T2.O	173	323	Point 2 outdoor temperature	0.1°C	-400	500	100	
T3.S	174	324	Point 3 pipe sensor temperature	0.1°C	0	1000	700	
T3.O	175	325	Point 3 outdoor temperature	0.1°C	-400	500	-150	
TJAN	179	329	Default outdoor temperature for January (BEM module: Default outdoor temperature without outdoor sensor)	0.1°C	-95	300	0	

See also:

7 "Menu parameters" on page 34

7. . Menu parameters

7.1 Introduction

This chapter describes the contents of the “settings.txt” file, and also the corresponding Modbus addresses.

The settings file can be given a name to identify the settings set.

Parameter

MENU PARAMETER	MODBUS	REQUIREMENTS
name	-	Maximum length 15 characters Allowed characters: a-z, A-Z, 0-9, “-” (hyphen) , “_” (underscore), “.” (full stop)

7.2 Switching the air curtain on and off

You can switch the air curtain on and off manually. Independently of this, the unit can be operated by external controls (see function [60. Function of input \(60. Function of input\)](#)).

Parameter

MENU PARAMETER	MODBUS	UNITS	MINIMUM	MAXIMUM	DEFAULT
0.1	10000	-	0	2	1

Values

VALUE	OPTION	DESCRIPTION
0	Off	The unit is switched off. <ul style="list-style-type: none"> The unit will react to signals on the inputs on the unit and on the control panel, and to the timer. The unit will start working when the temperature drops below the night temperature when this function is enabled. The frost protection is active.

VALUE	OPTION	DESCRIPTION
1	On	The unit is on (normal operation).
2	Frost protection mode	The unit is switched off. <ul style="list-style-type: none"> • The unit does not react to signals on the inputs or to the timer. • Night temperature is disabled. • The frost protection is active.

Switching the heating on and off

The heating from the air curtain can be switched ON/OFF manually. This can be useful in summertime when no heating is necessary.

Switching the heating off disables the room temperature control.

The heating can also be switched off by the control itself:

- by an external signal at the input of the unit, see [60. Function of input](#) ([60. Function of input](#)), setting [Heating off](#) ([Heating off](#));
- when the outdoor temperature is higher than the setting of function [84. Heating off temperature](#) ([84. Heating off temperature](#)).

Parameter

MENU PARAMETER	MODBUS	UNITS	MINIMUM	MAXIMUM	DEFAULT
0.2	10001	-	0	1	1

Values

VALUE	OPTION	DESCRIPTION
0	Heating off Untranslated: Heating off	Heating is switched off
1	Heating on	Heating is switched on

7.3 Manual setting of the strength

With the manual setting, you have 6 strengths to choose from. To achieve maximum climate separation with minimum energy consumption, Biddle recommends to select the lowest strength at which no draught occurs. This setting may need to be changed during the day.

Parameter

MENU PARAMETER	MODBUS	UNITS	MINIMUM	MAXIMUM	DEFAULT
0.3	10003	-	1	6	1

7.4 Adjust the automatic strength control

In automatic mode, the strength and temperature of the air stream are controlled automatically. Due to weather conditions, you might want to adjust the automatic setting. If you feel a cold draught along the floor, you can increase the automatic strength.



Note:

The adjustment of the automatic strength is not always directly translated into a different fan speed

Parameter

MENU PARAMETER	MODBUS	UNITS	MINIMUM	MAXIMUM	DEFAULT
0.4	10004	-	-3	3	1

7.5 Controlling the temperature

You can set the temperature to a comfortable level. This is the temperature at the air curtain. With units connected to a Daikin system (CA2 V and CA2 Q), the temperature control is less accurate than with water or electric heating.

Parameter

MENU PARAMETER	MODBUS	UNITS	MINIMUM	MAXIMUM	DEFAULT
0.5	10005	0.1 °C	150	400	210

7.6 Automatic or manual control

The air curtain has an automatic and a manual mode. When the unit is switched on, it is always in automatic mode.

Parameter

MENU PARAMETER	MODBUS	UNITS	MINIMUM	MAXIMUM	DEFAULT
0.6	10002	0	0	1	1

Values

VALUE	OPTION	DESCRIPTION
0	Manual	Manual control of the air curtain strength
1	Automatic	Automatic control of the air curtain strength

Temperature unit

Choose between temperature display in degrees Celsius and degrees Fahrenheit.

Parameter

MENU PARAMETER	MODBUS	UNITS	MINIMUM	MAXIMUM	DEFAULT
0.7	-	-	0	1	0

Values

VALUE	OPTION	DESCRIPTION
0	°C	Celsius
1	°F	Fahrenheit

Discharge temperature control

As default the discharge temperature is automatically controlled by the CHIPS control. You can set the discharge temperature to a fixed level, or based on the fan speed.

Parameter

MENU PARAMETER	MODBUS	UNITS	MINIMUM	MAXIMUM	DEFAULT
1	101	-	1	5	5

Values

VALUE	OPTION	DESCRIPTION
0	auto	Discharge temperature depending on fan speed
1	30°C	Discharge temperature fixed at 30°C
2	35°C	Discharge temperature fixed at 35°C
3	40°C	Discharge temperature fixed at 40°C
4	High/50°C	Maximal discharge temperature, limited to 50°C
5	CHIPS - PI-temperature control	Automatic discharge temperature control based on outdoor and indoor temperature.

Filter - Filter

Dirty filters reduce the effectiveness of the air curtain. It is therefore necessary to clean or replace the filters at regular intervals. The filter contamination is either measured with the optional filter sensor or calculated.

With the optional filter sensor, the unit measures the filter contamination every 24 hours by running at the highest fan speed for 40 seconds. You can set the check time for this in the menu.

**Warning:**

The default check time is 00:00 h (midnight). Be aware that objects can be put into motion by the airflow of the air curtain. This might set off an alarm system in the building at night time.

**Note:**

With the BEM module and Modbus communication, the contamination measurement needs to be started by writing value "1" in address [10112].

The cleaning interval can be adjusted to match the actual contamination of the filters.

The actual pressure difference at which the filters are considered to be dirty can be calculated using the formula below:

$$*.CL + \left(\frac{*.MX - *.MN}{2} \right) - \left(\frac{*.MX - *.MN}{6} \right) \cdot [3.2]$$

Without filter sensor the service life of the filter is calculated in relation to the use of the air curtain. You can adjust this by setting the maximum service life of the filter.

You may clean the filter with, for instance, a vacuum cleaner. After some cleanings, however, the filter must be replaced. New filters are available from Biddle.

Parameter

MENU PARAMETER	MODBUS	DESCRIPTION	UNITS	MINIMUM	MAXIMUM	DEFAULT
2	102	Reset filter	-	0	0	0
2.5	125	Lapsed life	weeks	0	0	0
3	103	Filter life	weeks	0	52	13
3.2	124	Cleaning interval adjustment	-	-3	3	0
4	104	Track filter life	-	0	1	1
S.CL	100	Clean level CA S	Pa	0	7500	51
S.MN	107	Lower limit CA S	Pa	0	255	12
S.MX	129	Upper limit CA S	Pa	0	255	26
M.CL	133	Clean level CA M	Pa	0	7500	101
M.MN	134	Lower limit CA M	Pa	0	255	14
M.MX	135	Upper limit CA M	Pa	0	255	42
L.CL	136	Clean level CA L	Pa	0	7500	120
L.MN	137	Lower limit CA L	Pa	0	255	23
L.MX	138	Upper limit CA L	Pa	0	255	63
X.CL	139	Clean level CA XL	Pa	0	7500	202
X.MN	140	Lower limit CA XL	Pa	0	255	36
X.MX	141	Upper limit CA XL	Pa	0	255	84

Values function 4:

VALUE	DESCRIPTION
0	track filter life
1	don't track filter life

5. Room temperature - 5. Room temperature

The default room temperature is the temperature setting at every start-up of the unit.

This can be overruled by menu parameter 0.5/Modbus address [10005].

Parameter

MENU PARAMETER	MODBUS	UNITS	MINIMUM	MAXIMUM	DEFAULT
5	105	0.1 °C	150	300	210

6. Minimum air temperature - 6. Minimum air temperature

Set the minimum difference between the room temperature and the discharge temperature.

This difference can be increased for more comfort. A small difference saves energy.

Parameter

MENU PARAMETER	MODBUS	UNITS	MINIMUM	MAXIMUM	DEFAULT
6	106	0.1 °C	-100	200	10

8. Night temperature - 8. Night temperature

The night temperature is used when the unit is off. When the room temperature drops below this setting, the unit will start working to keep the room on the night temperature.



Warning:
Be aware that objects can be put into motion by the airflow of the air curtain. This might set off an alarm system in the building at night time.

Parameter

MENU PARAMETER	MODBUS	DESCRIPTION	UNITS	MINIMUM	MAXIMUM	DEFAULT
8	-	Night temperature	0.1 °C	100	300	150
8.5	-	Sensor for night temperature	-	0	3	0

Values for parameter 8.5:

VALUE	OPTION	DESCRIPTION
0	Disabled	Night temperature disabled.
1	Control panel	Night temperature is measured at the control panel.
2	Disabled	Night temperature disabled.
3	Wireless sensor	Night temperature is measured at the wireless indoor sensor.

Default settings - Default settings

Restores the standard factory settings.

Parameter

MENU PARAMETER	MODBUS	UNITS	MINIMUM	MAXIMUM	DEFAULT
11	111	-	0	1	0

Values

VALUE	DESCRIPTION
0	no action
1	restore default settings

1. Select modes - 1. Select modes

With the BEM module you can select the default mode when the unit is switched on. Changing the value of this function to 1 or 2 will change also the value of function 0.2.

Parameters

MENU PARAMETER	MODBUS	UNITS	MINIMUM	MAXIMUM	DEFAULT
13	113	-	1	3	3

Values

VALUE	DESCRIPTION	VALUE OF FUNCTION 0.2
1	allowed: manual	0 (manual)
2	allowed: automatic	1 (automatic)
3	allowed: manual, automatic	0-1, 1 when the unit is switched on.

54. Strength with door closed - 54. Strength with door closed

Set the minimum fan speed when contact is made with the input. Use a door switch here to reduce the fan speed when the door is closed. This has an effect only when function 60. Function of input (60. Function of input) is set to Quick speed up (Quick speed up) or Slow speed up (Slow speed up).

If this function is set to zero (fans off), it can occur that the fans start working with the doors closed. This is to maintain the room temperature. If you don't want this:

- decrease the set room temperature, or:
- change this function to a value other than zero.

Parameter

MENU PARAMETER	MODBUS	UNITS	MINIMUM	MAXIMUM	DEFAULT
54	154	-	0	4	1

55. Boost function - 55. Boost function

If there is a large difference between the desired and the actual room temperature, the fan speed can be increased to reach the desired temperature quicker.

Use this function when the air curtain also is used for heating the room.

If 61a/b. Function of output 1/2 (61a/b. Function of output 1/2) is set to value Winter door setting (Winter door setting), a contact on that output is also made when the actual difference is larger than this setting.

Parameter

MENU PARAMETER	MODBUS	DESCRIPTION	UNITS	MINIMUM	MAXIMUM	DEFAULT
55	155	Temperature difference	0.1°C	-100	0	-10
55.5	145	Enable boost function	-	0	1	1
56	156	Fan speed increment	-	0	5	0
56.5	146	Release delay decreasing fan speed	s	0	100	0

58. Maximum strength - 58. Maximum strength

The maximum fan speed can be limited in order to limit the noise level. This function has an effect only in Automatic mode.

Use of this function can reduce the comfort.

Parameter

MENU PARAMETER	MODBUS	UNITS	MINIMUM	MAXIMUM	DEFAULT
58	158	-	3	6	6

59. Sensor X82 - 59. Sensor X82

The sensor connected to terminal X82 on the unit can act as either an outdoor sensor or as a pipe sensor on the supply pipe of the central heating system. This sensor is used in the automatic control of the air curtain.

Pipe sensor

The outdoor temperature is derived from the water temperature. For this you need a pipe sensor on the supply pipe of the central heating system and a weather depended control of the central heating system.

The outdoor temperature is based on the heating curve of the supplied water. This curve is defined by three points of outdoor temperature and water temperature.

The first point is for the high outdoor temperature, the last point for the low outdoor temperature. Make sure that the limits of all temperatures correspond to the temperatures that can occur.

As this is only an estimation, the working of the air curtain might be less optimal.

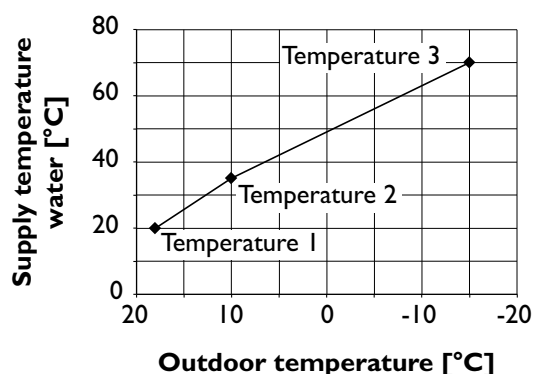

Parameter

MENU PARAMETER	MODBUS	DESCRIPTION	UNITS	MINIMUM	MAXIMUM	DEFAULT
59	159	Sensor function	-	0	1	0
T1.S	149	Point 1 pipe sensor temperature	0.1 °C	0	1000	200
T1.O	168	Point 1 outdoor temperature	0.1 °C	-400	500	180
T2.S	170	Point 2 pipe sensor temperature	0.1 °C	0	1000	350

MENU PARAMETER	MODBUS	DESCRIPTION	UNITS	MINI-MUM	MAXI-MUM	DEFAULT
T2.O	173	Point 2 outdoor temperature	0.1 °C	-400	500	100
T3.S	174	Point 3 pipe sensor temperature	0.1 °C	0	1000	700
T3.O	175	Point 3 outdoor temperature	0.1 °C	-400	500	-150

Values for parameter 59:

VALUE	DESCRIPTION
0	outdoor sensor
1	pipe sensor

60. Function of input - 60. Function of input

The unit has one input which can be used to have a function controlled by an external accessory such as a door switch, thermostat or a signal from a building management system (BMS).

If several units are connected to a single BEM-module, only one input can be used. The effect of this input is then the same for all the units.

The function **Unit off locally (Unit off locally)** has an effect only on the units whose inputs are in use.

When the timer is in use, the function **Switch all units on/off (Switch all units on/off)** of the input on the unit is deactivated, irrespective of this setting.

With the setting **Switch all units off (Switch all units off)** a jumper must be laid to the input for all the other connected units.

Parameter

MENU PARAMETER	MODBUS	UNITS	MINIMUM	MAXIMUM	DEFAULT
60	160	-	0	71	0

Values

VALUE	OPTION	DESCRIPTION
0	No function	The input has no function.
1	Unit off locally - NO	The unit switches OFF when the contact is closed.\nOnly units to which the input signal is directly connected (locally).
51	Unit off locally - NC	The unit switches OFF when the contact is open.\nOnly units to which the input signal is directly connected (locally).
2	1 strength up - NO	The unit operates 1 strength up when the contact is closed.\n(Only for automatic mode)
52	1 strength up - NC	The unit operates 1 strength up when the contact is open.\n(Only for automatic mode)
3	2 strengths up - NO	The unit operates 2 strengths up when the contact is closed.\n(Only for automatic mode)
53	2 strengths up - NC	The unit operates 2 strengths up when the contact is open.\n(Only for automatic mode)
4	Increase heating	The discharge air temperature is increased by 5 °C when the contact is closed.
21	Switch all units on Untranslated: Switch all units on	All units are switched ON when the contact is closed.
71	Switch all units off Untranslated: Switch all units off	All units are switched OFF when the contact is closed.
7	Quick speed up - NO	The unit speeds up quickly when the contact (for example a door switch) is closed.\n(Only for automatic mode)
57	Quick speed up - NC	The unit speeds up quickly when the contact (for example a door switch) is open.\n(Only for automatic mode)
8	Slow speed up - NO	The unit speeds up slowly when the contact (for example a door switch) is closed.\n(Only for automatic mode)
58	Slow speed up - NC	The unit speeds up slowly when the contact (for example a door switch) is open.\n(Only for automatic mode)
6	Heating off Untranslated: Heating off	The heating is switched OFF when the contact is closed.
9	Release - NO	The user is allowed to switch the unit on and off when the contact is closed.
59	Release - NC	The user is allowed to switch the unit on and off when the contact is open.

61a/b. Function of output 1/2 - 61a/b. Function of output 1/2

The unit has an interface for two output signals: These can be used, for example, for controlling the central heating or cooling system, or for transmitting status reports to a BMS.

The outputs function independently of one another.

Multiple units operated from one BEM-module.

The outputs always have a global effect: the signals are always the same in all units connected to the control panel.

Parameter

MENU PARAMETER	MODBUS	DESCRIPTION	UNITS	MINI-MUM	MAXI-MUM	DEFAULT
61	161	Output O1-O1	-	1	52	1
61b	147	Output O2-O2	-	1	52	1

Values

VALUE	OPTION	DESCRIPTION
1	Fault - NO	The contact is closed when a fault occurs.
4	Fault or dirty filter - NO	The contact is closed when a fault occurs or when the maximum filter life is lapsed.
2	Filter life lapsed - NO	The contact is closed when the maximum filter life is lapsed.
51	Fault - NC	The contact is opened when a fault occurs.
52	Filter life lapsed - NC	The contact is opened when the maximum filter life is lapsed.
3	Heating deficit	The contact is closed when the unit can not reach the desired air temperature.
8	Unit on	The contact is closed when the unit is switched on.
13	Heating on Untranslated: Heating on	The contact is closed when the unit requires heating. Use this to switch the heating system ON/OFF via the unit.
15	Risk of freezing Untranslated: Risk of freezing	The contact is closed when the temperature inside the unit drops below 7 °C.
17	Winter door setting Untranslated: Winter door setting	The contact is closed when the temperature difference between the desired and room temperature is larger than the value set in function 55. Winter door setting.
18	DX unit defrost	The contact is closed when the unit is temporary not heating because of a defrosting cycle.
19	IR contact made - NO	The contact is closed when the IR sensor detects motion.
69	IR contact made - NC	The contact is opened when the IR sensor detects motion.

PID factors - PID factors

PID factors for the room temperature control and for the outlet temperature control.

**Note:**

Do not change these settings, unless on Biddle's instructions.

Parameters of room temperature PID-controller

MENU PARAMETER	MODBUS	DESCRIPTION	UNITS	MINIMUM	MAXIMUM	DEFAULT
62	162	P-factor	-	0	99	3
63	163	I-factor	-	0	99	50
64	164	D-factor	-	0	99	0

Parameters of unit outlet temperature PID-controller

MENU PARAMETER	MODBUS	DESCRIPTION	UNITS	MINIMUM	MAXIMUM	DEFAULT
65	165	P-factor	-	0	99	50
66	166	I-factor	-	0	99	10
67	167	D-factor	-	0	99	0

Factory configuration - Factory configuration

Restores the standard factory configuration. All settings are then lost.

Parameter

MENU PARAMETER	MODBUS	UNITS	MINIMUM	MAXIMUM	DEFAULT
71	171	-	0	1	0

Values and explanation

VALUE	DESCRIPTION
0	no action
1	restore default factory configuration

72. Error display - 72. Error display

Some fault messages may be caused by external factors such as the central heating system and do not necessarily have an influence on the function of the air curtain.

Use this function to suppress these messages. Messages concerning safety are always displayed.

Parameter

MENU PARAMETER	MODBUS	UNITS	MINIMUM	MAXIMUM	DEFAULT
72	172	-	0	3	1

Values

VALUE	OPTION	DESCRIPTION
0	Disable	Disable displaying fault messages F1, F2 and F3.
1	Enable	Enable displaying fault messages F1, F2 and F3.
2	Enable F2/F3 only	Enable displaying fault messages F2 and F3. Fault message F1 is disabled.
3	Enable F1 only	Enable displaying fault message F1. Fault messages F2 and F3 are disabled.

76. Release delay input - 76. Release delay input

When you are using an input, you can allow the effect of an incoming signal to continue for some time after the signal has passed ('release delay'). This setting can be used, for example, in combination with a door switch to allow the unit to continue to run for a short time after the door has been closed.

Parameter

MENU PARAMETER	MODBUS	UNITS	MINIMUM	MAXIMUM	DEFAULT
76	176	s	0	1000	0

77. Valve position unit off - 77. Valve position unit off

When the unit is switched off, the valve in the unit is closed by default.

Select **Valve open** (**Valve open**) and set the opening percentage of the valve to always keep a flow over the heat exchanger into the unit.

Parameter

MENU PARAMETER	MODBUS	DESCRIPTION	UNITS	MINIMUM	MAXIMUM	DEFAULT
77	177	Valve position	-	0	1	0
77.5	148	Opening percentage	%	2	100	5

77.5 has only effect when 77 is set to 1. 77.5 is the percentage that the valve is opened.

Values

VALUE	OPTION	DESCRIPTION
0	Valve closed	Valve is closed when the unit is off.
1	Valve open untranslated: Valve open	Valve is opened when the unit is off.

78. Valve position fans off - 78. Valve position fans off

When the fans are switched off, the position of the water valve depends on the temperature control.

Set the opening percentage of the valve to always keep a flow over the heat exchanger in the unit when the fans are off. This is relative to the position the valve has when the fans are running.

This way heat is always directly available

Parameter

MENU PARAMETER	MODBUS	UNITS	MINIMUM	MAXIMUM	DEFAULT
78	178	%	0	100	5

80. Fan off temperature - 80. Fan off temperature

When there is only a small difference in temperature between outdoors and indoors, there is less need for a climate separation. In order to save energy, the fans can be switched off when there is only a small difference in temperature.

Set this value to zero to allow the fans to run at all times.

Parameter

MENU PARAMETER	MODBUS	UNITS	MINIMUM	MAXIMUM	DEFAULT
80	180	0.1°C	0	100	0

82. Installation height - 82. Installation height

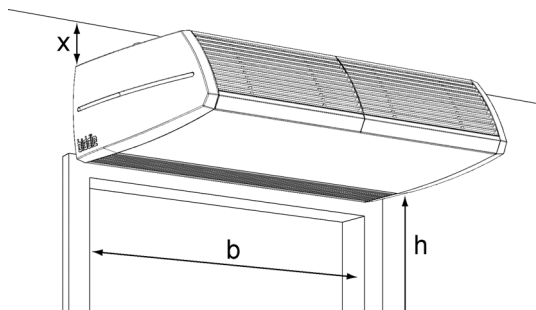

In order to use the automatic control as efficiently as possible and with minimum energy consumption it is necessary to set the installation height of the air curtain correctly.

If there is a continuously large draught through the door, this value can be increased in order to adapt the strength of the air curtain.

The installation height is the distance h between the floor and the underside of the discharge grille.

Parameter

MENU PARAMETER	MODBUS	UNITS	MINIMUM	MAXIMUM	DEFAULT
82	182	cm	100	500	240

84. Heating off temperature - 84. Heating off temperature

If the outdoor temperature rises above this setting, the heating of the air curtain is switched off.

A higher value offers greater comfort, a lower value saves energy.

Parameter

MENU PARAMETER	MODBUS	UNITS	MINIMUM	MAXIMUM	DEFAULT
84	184	0.1°C	-95	300	180

86. IR sensor - 86. IR sensor

The unit can be optionally equipped with an IR sensor in the discharge grille.

This sensor is used to give an indication of the number of people passing underneath the air curtain. This indication can be read out in the status screen and in the log-files.

The IR sensor can also be used to switch on the unit for 30 minutes every time it detects motion, and it can be used instead of a door switch. Choosing this last function disables the input on the unit for this function.

Parameter

MENU PARAMETER	MODBUS	UNITS	MINIMUM	MAXIMUM	DEFAULT
86	186	-	0	7	0

Values

VALUE	DESCRIPTION
0	no function enabled
1	The unit will be switched on for 30 minutes.
2	The IR sensor acts as a door switch. The unit speeds up slowly when the sensor detects motion.
3	The unit will be switched on for 30 minutes, and the IR sensor acts as a door switch. The unit speeds up slowly when the sensor detects motion.
4	The IR sensor acts as a door switch. The unit speeds up quickly when the sensor detects motion.
5	The unit will be switched on for 30 minutes, and the IR sensor acts as a door switch. The unit speeds up quickly when the sensor detects motion.

87. Wireless sensors - 87. Wireless sensors

The wireless outdoor sensor replaces the wired outdoor sensor.

Parameter

MENU PARAMETER	MODBUS	UNITS	MINIMUM	MAXIMUM	DEFAULT
87	187	-	0	7	0

Values

VALUE	OPTION	EXPLANATION
0	disable	All wireless sensors are disabled
1	enable outdoor	Only outdoor sensor enabled (indoor sensor is disabled)

88. Outdoor temperature - 88. Outdoor temperature

The CHIPS automatic control needs an outdoor temperature to calculate the optimal setting.



Note:
The automatic control is less efficient without an outdoor sensor.



Note:
With the BEM module the value of address [179] is used as outdoor temperature when the control has no input of an outdoor temperature.

Default month temperatures

MENU PARAMETER	MODBUS	DESCRIPTION	UNITS	MINIMUM	MAXIMUM	DEFAULT
TJAN	179	January	0.1 °C	-95	300	0

Reset control panel - Reset control panel

The BEM-module searches for connection with the connected units again. Use this function when remedying faults and during connection or disconnection of units.

Parameter

MENU PARAMETER	MODBUS	UNITS	MINIMUM	MAXIMUM	DEFAULT
98	198	-	0	1	0

Values

VALUE	DESCRIPTION
0	no action
1	reset control panel

8 . . Other Modbus addresses

ADDRESS	DESCRIPTION	TYPE	RO/RW/EEP
1	Modbus address	uint16	rw,EEP
2	Endianness setting	uint16	rw,EEP
4	Baud rate	Baudrate_t	rw,EEP
5	Serial number	uint16	ro
6	Reset	Command_t	wo
10	Modbus revision	uint16	ro
11	Firmware version	uint16	ro
15	Biddle version	uint16	ro
30	Modbus CRC errors	uint16	ro
50	Number of connected units	uint16	ro
600	Serial number printed circuit board - unit 1	uint32	ro
602	Configuration code - unit 1	uint16	ro
603	Software version printed circuit board - unit 1	uint16	ro
605	Analogue sensor type – Unit 1 1 = flow sensor 2 = filter sensor 3 = no sensor	uint16	ro
606	Serial number printed circuit board - unit 2	uint32	ro
608	Configuration code - unit 2	uint16	ro
609	Software version printed circuit board - unit 2	uint16	ro
611	Analogue sensor type – Unit 2	uint16	ro
612	Serial number printed circuit board - unit 3	uint32	ro
614	Configuration code - unit 3	uint16	ro
615	Software version printed circuit board - unit 3	uint16	ro
617	Analogue sensor type – Unit 3	uint16	ro
618	Serial number printed circuit board - unit 4	uint32	ro
620	Configuration code - unit 4	uint16	ro
621	Software version printed circuit board - unit 4	uint16	ro
623	Analogue sensor type – Unit 4	uint16	ro
624	Serial number printed circuit board - unit 5	uint32	ro
626	Configuration code - unit 5	uint16	ro
627	Software version printed circuit board - unit 5	uint16	ro
629	Analogue sensor type – Unit 5	uint16	ro

ADDRESS	DESCRIPTION	TYPE	RO/RW/EEP
701	Desired discharge air temperature (0.1°C)	uint16	ro
904	Fan speed	int16	ro
905	Current pressure difference sensor in unit 1 (0.1 Pa)	int16	ro
906	Current pressure difference sensor in unit 2 (0.1 Pa)	int16	ro
907	Current pressure difference sensor in unit 3 (0.1 Pa)	int16	ro
908	Current pressure difference sensor in unit 4 (0.1 Pa)	int16	ro
909	Position of heating valve - unit 1 (%)	int16	ro
910	Position of heating valve - unit 2 (%)	int16	ro
911	Position of heating valve - unit 3 (%)	int16	ro
912	Position of heating valve - unit 4 (%)	int16	ro
10050	Air inflow temperature	int16	ro
10051	Discharge air temperature	int16	ro
10052	Current outdoor temperature	int16	ro
10053	Filtered outdoor temperature This is used in the regulation.	int16	ro
10055	Fault codes 1	uint16	ro
10056	Current heating capacity (W/m)	int16	ro
10057	Door open/shut ratio	uint16	ro
10058	Number of switching actions on the unit's input	uint16	ro
10059	Fault codes 2	int16	ro
10060	Number of switching actions on the unit's IR sensor. If the IR sensor is also used as a door switch, the "Door open/shut ratio" is based on this sensor.	uint32	ro
10062	Number of switching actions on the unit's input	uint32	ro
10100	Time remaining in test mode	uint16	ro
10101	Test mode	TestMode_t	rw
10102	Duration of the test mode in s	uint16	rw
10110	Filter contamination as %	uint16	rw
10111	Measurement of filter contamination or calibration active (0=inactive; 1=active)	uint16	rw
10112	Measure filter contamination/Calibrate filter sensor	uint16	w
10120	Current outdoor temperature input	int16	rw

See also:

10.2.2 "Fault Codes Register 10055/Errflags" on page 61

10.2.3 "Fault codes register 10059/Errflags2" on page 62

3.2 "The test function" on page 13

3.3.4 "Setting the outdoor temperature via Modbus (optional)" on page 17

8.1 Register types

TYPE	LENGTH (WORDS)	DESCRIPTION
int16	1	Signed Integer (-32768 to 32767)
uint16	1	Unsigned Integer (0-65536)
uint32	2	Unsigned Integer (0-4294967296)
Baudrate_t	1	0 = 9600; 1 = 19200; 2 = 38400; 3 = 57600; 4 = 115200; 255 = unset (use default, 9600)
Command_t	1	1 = Reset

9 . . Log Files

In the BEM module, data about usage is recorded in various log files. These files, together with the settings, can be read out via a USB flash drive. At the same time, settings can be imported.



Note:

The BEM module does not have an internal clock, so time and date are not recorded. The files contain a default date and time.

FILE NAME	DESCRIPTION	WHEN DATA IS WRITTEN:
Log_debug.csv	(not used)	-
Log_error.csv	Log file with fault codes	When a fault occurs
Log_func.csv	File with current usage data	Every 2.5 minutes
Log_stat.csv	File with statistical usage data	Every 24 hours
Log_task.csv	(not used)	-
Log_user.csv	Log file with settings	When a menu parameter is changed
Settings_export.txt	Export file with the current settings	
Settings.txt	Import file with new settings	-

- Connect a USB flash drive to the BEM module. The green USB LED will flash slowly.
- Press the test button briefly. The green USB LED flashes rapidly while the log files are being written and while the configuration file (if available) is being read.



Caution:

If the file “settings.txt” is available on the USB flash drive, this overwrites the old settings. To restore the old settings, the file “settings_export.txt” must be renamed “settings.txt”.



Caution:

Existing log files are overwritten. To read out multiple BEM modules, you should therefore use several USB flash drives or copy the files before reading out a subsequent module.

9.1 Log_error.csv

The file "log_error.csv" contains an overview of faults that have occurred. This file is written when a fault occurs.

FIELD	DESCRIPTION	UNIT
date	Date	dd-mm-yy
time	Time	H:mm:ss
gmt+dst	Summertime correction	hour
error type	Fault code	-

See also:

10 "Faults" on page 60

9.2 Log_func.csv

The file "log_func.csv" contains current usage data and is written every 2.5 minutes.

FIELD	DESCRIPTION	UNIT
date	Date	dd-mm-yy
time	Time	H:mm:ss
gmt+dst	Summertime correction	hour
outdoor sensor	Temperature of the sensor that is used for the outdoor temperature.	0.1°C
inlet sensor	Air inflow temperature at the unit	0.1°C
discharge sensor	Air discharge temperature from the unit	0.1°C
fan speed	Fan speed	-
heat input (kW*100)	Current heating capacity	100kW
room sensor	Temperature of the sensor that is used to measure the room temperature.	0.1°C
discharge setpoint	Desired air discharge temperature	0.1°C
input open/close ratio	Open/shut ratio of the door switch	%
U0T (*1000)	Strength figure (this is not the discharge speed from the unit)	m/s
Room set point	Pre-set room temperature	0.1°C

9.3 Log_stat.csv

The file “log_stat.csv” contains statistical usage data and is saved every 24 hours.

FIELD	DESCRIPTION	UNIT
date	Date	dd-mm-jj
time	Time	U:mm:ss
gmt+dst	Summertime correction	uur
air curtain active(minutes)	Time that the air curtain has been on	m
input cnt	Number of switching actions on the input	-
input active(%)	Percentage that the input on the unit has been active	%
energy consumption(0,1 kwh/meter)	Energy consumption	0.1 kW/m
min outdoor temp	Minimum outdoor temperature	0.1 °C
max outdoor temp	Maximum outdoor temperature	0.1 °C
PIR cnt	Total number of switching actions on the IR sensor	-
PIR cnt day	Number of switching actions on the IR sensor on the relevant day	-
Filter pressure (pa)	Pressure measured when measuring filter contamination	Pa

9.4 Log_user.csv

The file “log_user.csv” contains an overview of a number of settings. This file is written if one of these parameters is changed. For a detailed description of the fields, see the description of the relevant parameters.

FIELD	PARAMETER	DESCRIPTION	UNIT
date	-	Date	dd-mm-yy
time	-	Time	H:mm:ss
gmt+dst	-	Summertime correction	hour
menu 0.1	0.1	Unit on/off	0 = off 1 = on
menu 0.2	0.2	Heating on/off	0 = off 1 = on
menu 1	1	Air discharge temperature control	-
menu 2	2	Reset filter	-
menu 2.5	2.5	Elapsed life of filter	w
menu 3	3	Lifetime of filter	w

FIELD	PARAMETER	DESCRIPTION	UNIT
menu 4	4	Monitor filter contamination	0 = on 1 = off
menu 5	5	Standard room temperature	0.1°C
inlet temperature lower limit	-	(not used)	-
menu 6	6	Minimum air temperature	0.1°C
menu 9	9	Calibration	0.1°C
menu 10	10	Current errors	-
temperature sp	0.5	Pre-set room temperature	0.1°C
mode	0.6	Automatic or manual control	0 = manual 1 = automatically
strength auto	0.4	Adjusting the automatic strength	-
strength manual	0.3	Setting the manual strength	-
brightness	12	Brightness screen	%
modes	13	Permitted settings	-
language	14	Language	-
dst	15	Automatic summertime	-

See also:

7 "Menu parameters" on page 34

10 Faults

10.1 Resolving simple problems

PROBLEM	POSSIBLE CAUSE	SOLUTION
The LEDs on the BEM module flash at irregular intervals and no connection can be made	The distance between the BEM module and the first unit is too big, which means the unit is not getting enough power.	<ul style="list-style-type: none"> Place the BEM module closer to the unit. Remove excess control cable. Connect a separate power supply to the BEM module.
Two left-hand LEDs remain OFF during Modbus communication.	No communication with the Modbus network.	<ul style="list-style-type: none"> Check the connection and the cables of the Modbus network.
The LEDs on the BEM module are illuminated but the module does not respond to Modbus commands.	The wiring has been connected wrongly.	<ul style="list-style-type: none"> Reverse the Modbus A- and Modbus B+ connections.
	The BEM module has the wrong Modbus address.	<ul style="list-style-type: none"> Check the Modbus address of the BEM module. Restore the default settings. The Modbus address is reset to 240.
	The baud rate of the Modbus system has been set wrongly.	<ul style="list-style-type: none"> Set the Modbus system to the correct baud rate. <p>The default value for the BEM module is 9600.</p>
The values of the readings are not right.	The wrong address is being read.	<ul style="list-style-type: none"> Read the right address.
	The values are being read in the wrong order.	<ul style="list-style-type: none"> Check the endianness [2] and change it if necessary.
	The read-out type is wrong.	<ul style="list-style-type: none"> Check the type of the address.
The LED at Modbus interface is flashing.	An invalid value has been sent via the SETBEMS command or via one of the Modbus addresses [10000] to [10005].	<p>To stop the flashing:</p> <ol style="list-style-type: none"> Disconnect the BEM module from the Biddle network and from any applicable external power supply. Connect the cables again. <p>The flashing does not affect the operation of the BEM module.</p>

PROBLEM	POSSIBLE CAUSE	SOLUTION
There are faults in the communication and the value of the Modbus address [30] is rising.	Poor Modbus cabling.	<ul style="list-style-type: none"> • Replace the cabling with a better quality. • Use shielded cable.
	Excessively long Modbus cabling.	<ul style="list-style-type: none"> • Remove excess cabling. • Place the BEM module closer to the Modbus system.
	Multiple masters are connected in the Modbus system.	The Modbus protocol prescribes a single master. Remove all the masters but one.
	Communication speed too high.	Lower the baud rate.

10.2 Reading out faults

10.2.1 Reading Out Faults

Faults are recorded with a binary code in two registers. For Modbus, these are registers 10055 and 10059. When reading out via RS232, the fault codes are shown after “errflags” and “errflags2”. The bit value is the status of the error message: bit=0 is ‘not active’, 1 is ‘active’.

In log file “log_error.csv”, which can be read out with a USB flash drive, the faults are indicated with a numeric value.

10.2.2 Fault Codes Register 10055/Errflags

For an explanation of the error messages, read the manual for the CA₂ air curtain.

	BEMS/ERRFLAGS; MODBUS10055	LOG_ERROR.CSV		
BIT	VALUE	VALUE	CODE	DESCRIPTION
0	1	0	E6	Risk of freezing
1	2	1	E2	Wrong connection
2	4	2	E1	No communication
3	8	3	E7	Fan not running
4	16	4	E3	Too much heating
5	32	5	E5	Heating stays on
6	64	6	E4	Too much heating
7	128	7	F2	Too much heating
8	256	8	F3	Too little heating

	BEMS/ERRFLAGS; MODBUS 10055	LOG_ERROR.CSV		
BIT	VALUE	VALUE	CODE	DESCRIPTION
9	512	9	F5	Defective air discharge sensor
10	1024	10	F6	Defective air inflow sensor
11	2048	11	F4	Control panel sensor defective
12	4096	12	F8	Defective pressure sensor
13	8192	13	F1	Fault in air valve
14	16384	14	F2	Too much cooling
15	32768	15	F3	No cooling

10.2.3 Fault codes register 10059/Errflags2

	BEMS/ERRFLAGS2 MODBUS 10059	LOGERROR.CSV		
BIT	VALUE	VALUE	CODE	DESCRIPTION
0	1	16	-	Filters need cleaning
1	2	17	-	No power supply
2	4	18	-	Outdoor sensor - replace battery
3	8	19	-	Indoor sensor - replace battery
4	16	20	F7	Defective outdoor sensor
5	32	21	F11	Defective pipe sensor
6	64	22	F9	Defective wireless outdoor sensor
7	128	23	F10	Defective wireless indoor sensor
		24		Filter contamination test

10.3 Deleting faults

Most fault messages will disappear automatically when the problem is resolved. Certain faults have to be remedied, however, by deleting the error message:

METHOD	ACTION
Via test button on BEM module	Press test button for 3 seconds
Via RS232	“RESET” command
Via Modbus	Write value “1” in address 198

Copyright and trademarks

All information and drawings contained in this manual remain the property of Biddle and may not be used for any purpose other than that intended, photocopied, duplicated, translated and/or published without prior written permission from Biddle.

Biddle's name is a registered trademark belonging to Biddle BV.

Warranty and liability

Please refer to the sale & delivery terms & conditions for information about the warranty and liability.

Biddle excludes any consequential damages at all times.

Manual liability

Although the greatest care and attention has been paid ensuring that all relevant components have – where required – been described fully and accurately, Biddle cannot be held liable for any damages arising as a result of errors and/or omissions in this manual.

Biddle reserves the right to change specifications as listed in this manual.

Please inform us of any errors or confusing issues that you may discover in this manual. This will help us to improve our documentation still further.

For more information

If you should have any comments or questions about this product, then please do not hesitate to contact Biddle.

Address for the UK:

Biddle Air Systems Ltd.

St. Mary's Road
Nuneaton
Warwickshire CV11 5AU
United Kingdom

tel: 024 7638 4233
fax: 024 7637 3621

e-mail: sales@biddle-air.co.uk
internet: www.biddle-air.com

Address for Canada:

Biddle Air Systems Ltd.

11 King St. Unit #3,
Barrie, ON L4N 6B5
Canada

tel: 705-797-0007
fax: 705-797-0013
toll free: 866-693-4333

e-mail: biddle@biddle.ca
internet: www.biddle.ca

Address for other countries:

Biddle bv

P.O. Box 15
NL-9288 ZG Kootstertille
The Netherlands

tel: +31 512 33 55 24
fax: +31 512 33 55 54

e-mail: info@biddle.nl
internet: www.biddle.info