

HEATRAE SADIA

SMARTER | CLEANER | WARMER

HEATRAE SADIA PACKAGED SOLUTIONS

HiMax Store

PRODUCT OVERVIEW

Frame mounted Heat Interface Unit (HIU) and Megaflo Eco unvented cylinder.

The HiMax Store is an HIU working in conjunction with a Megaflo Eco indirect cylinder to provide heating and hot water to the home. The unit comes with factory fitted pipework and is supplied with a pre-fabricated frame saving time and cost on installation.

The HiMax Store is part of the range of Heatrae Sadia Packaged Solutions, designed to provide energy efficiency solutions to heating, hot water and ventilation where space saving is key.



72 l/min at 3 bar

(Megaflo Eco)

125 – 300 litre

Nominal capacity

60mm insulation

(Megaflo Eco)

Up to 529L

First hour performance

Features	Benefits
High performance plate heat exchanger	Keeps return temps to primary circuit to a minimum
Option for none, one or two heating zones	Flexibility in specification of package
Factory fitted cylinder pipework	Saves time and cost on installation
Frame mounted	Able to maximise space in dwelling
Duplex stainless steel inner container	Lifetime cylinder warranty

HIMAX STORE HIU DIMENSIONS

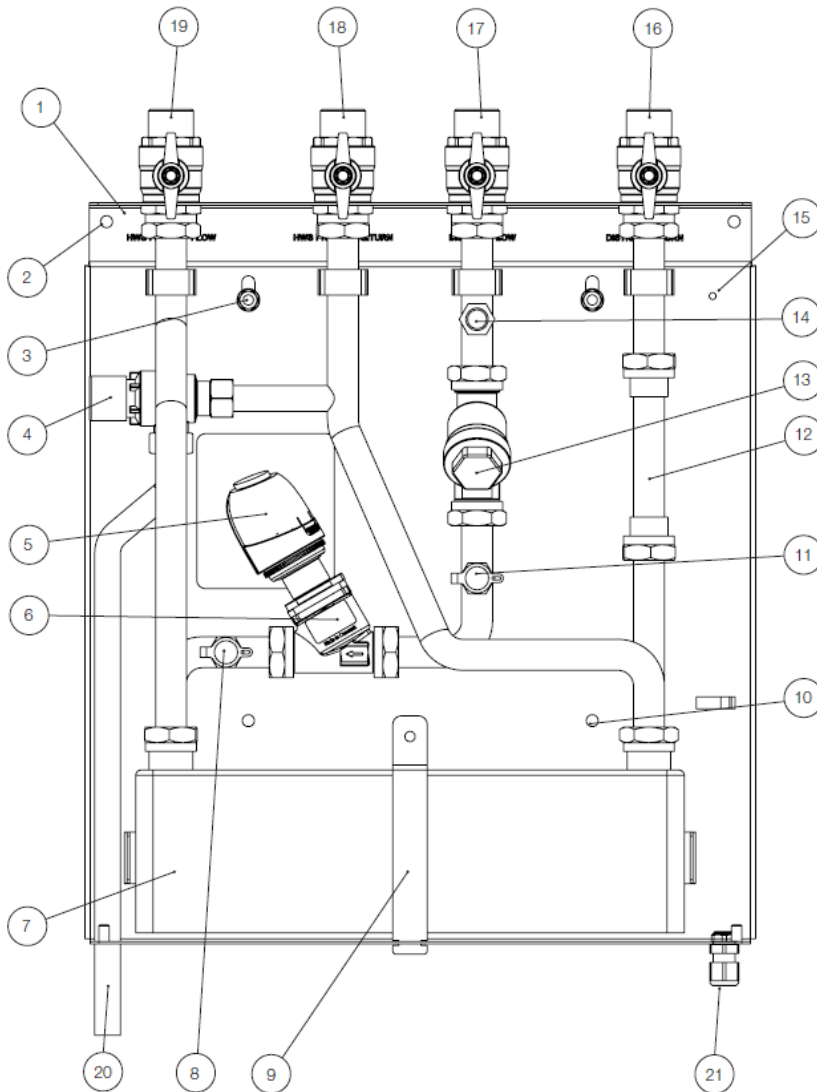

1. First fix rail bracket
2. 4 no. fixing holes
3. HIU mounting studs
4. 15mm central heating system safety valve 3 bar
5. 230V on/off thermo actuator
6. DN 15 Frese Optima Compact pressure independent balancing and control valve
7. Plate Heat Exchanger
8. Test point for pressure drop across district control valve
9. Plate Heat Exchanger support bracket
10. Wall mounted holes
11. Test point for pressure drop across district control valve
12. Volume flow meter spool piece
13. 3/4" bsp male Y strainer
14. 1/4" bsp heat meter flow sensor pocket
15. Earth stud (M4)
16. District heating return
17. District heating flow
18. HWS primary return
19. HWS primary flow
20. Safety valve discharge pipe
21. M12 cable gland

Unit	Height	Width	Depth	Dry Weight (kg)	Wet Weight (kg)
Dimensions (mm)					
HiMax Store with case	538	395	123	11.2	13.0
HiMax Store 1 st fix rail				1.6	1.6

HIMAX STORE CYLINDER DIMENSIONS

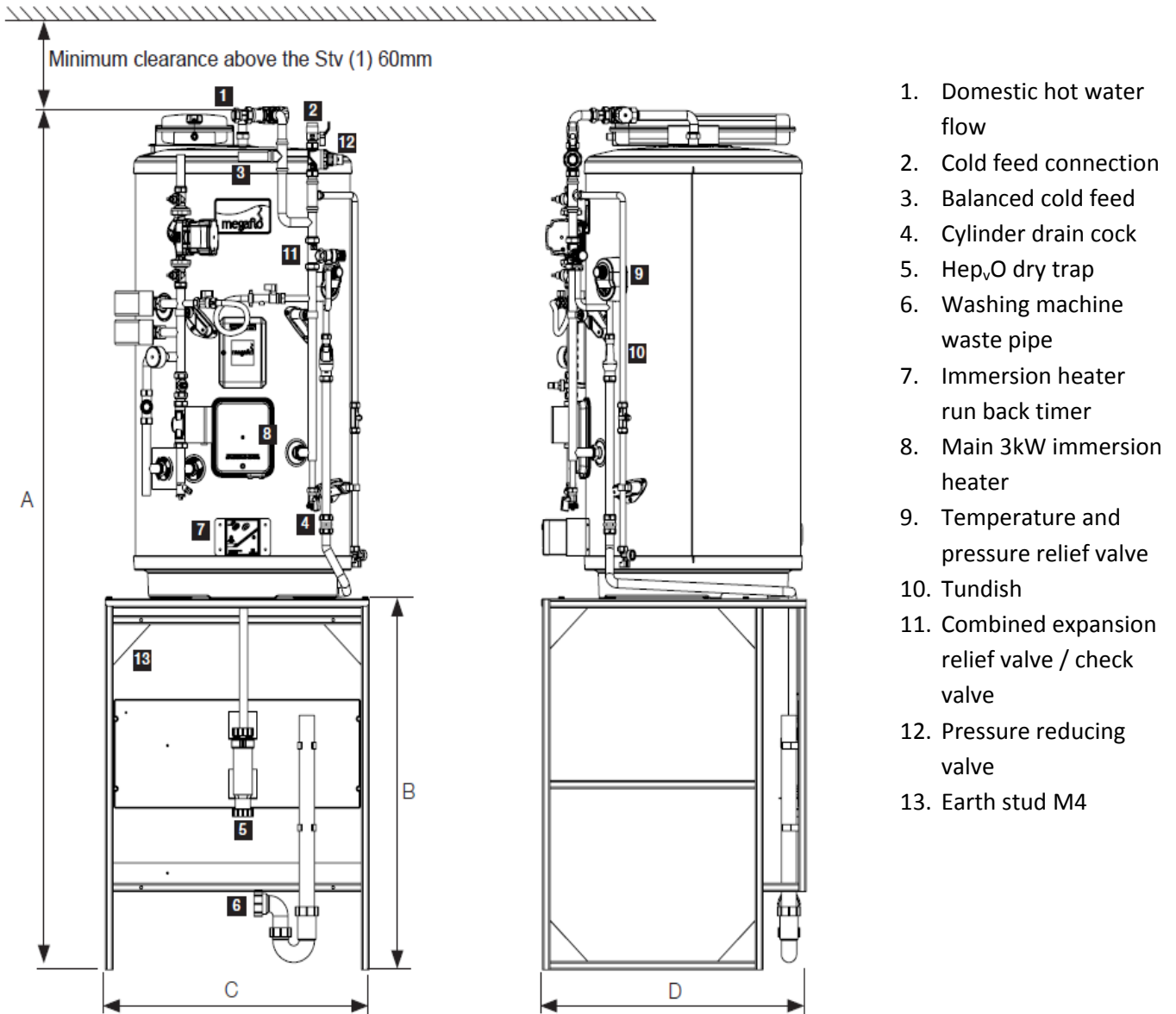

Cylinder size	125i	145i	170i	210i	250i	300i
Dimensions (mm)						
A	2096	2217	2379	1584*	1855*	2053*
B	900	900	900	-	-	-
C	700	700	700	630	630	630
D	700	700	700	700	700	700

*no frame available