

Issued - 14 February 2013

XERO 83 - Linear Floor Drain

The XERO 83 is a unique stainless steel shower gully for concrete floors. Fitted with a correct UK regulation 50mm deep water seal foul air trap, the extra low profile cross section has the lowest build in height of any drain on the market. With 2x traditional style height adjustable grates, the ZERO 83 also offers factory fit water resistant collar & high flow rates to suit all showers installations. E&OE

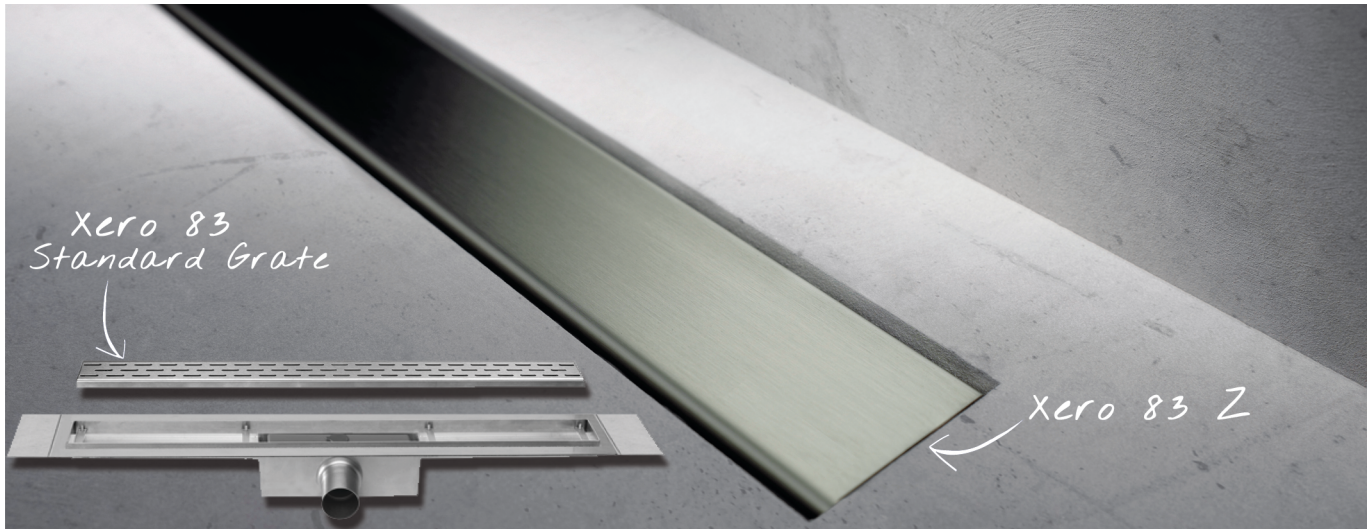

PRODUCT CHARACTERISTICS

- Ultra low profile linear floor drain with a minimum 83mm build in height, especially for CONCRETE floors.
- Comes with a 'Fixt 1' style of pierced grate as standard, while XERO 83-Z offers a plain & elegant grate
- All grates can be adjusted to match surrounding floor height
- Centrally located horizontal outlet to DN50 exits from front of welded foul air trap (c/w 50mm deep water seal)
- High Quality 304 Stainless Steel offers reliable resistance to chemical attack
- Supplied complete with levelling feet especially for concrete floors
- Factory fit water resistant reinforcing collar fitted to drain that when combined with additional tanking membranes seals drain to the floor structure, creating permanent barrier to water ingress

APPLICATIONS

'XERO 83' Shower Channel floor drains are wide collection vessels used within the floor of wet room showers & are offered in various lengths. Suits:

- Floor Structures – Designed especially for ultra low build-in height screeds in concrete floors.
- All Showers – specifically showers needing a discrete installation by using the slim & elegant grates.
- En-Suites – small bathrooms where space efficiency is at a premium
- High End Designer Bathrooms – adds to the feeling of space within a bathroom or shower area
- Refurbishments & New Build Projects

TECHNICAL DATA

- Floor Build in Height : 83mm minimum to 'finished floor'.
- Size Channel, Standard : 500, 600, 700, 800, 900, 1000, 1100, 1200mm. Up to 2000mm by special order only.
- Gully Profile : 20mm deep chassis, to suit concrete floor structures
- Waste & Foul Air Trap : EN1253-2, with UK regulation 50mm deep water seal, with rodding access
- Waste Connection : Outlet DN 50mm connection, with BS 2" adaptor
- Suitable Floor Covering : Adjustable grates suit minimum 7mm (or greater) Tile / Natural Stone
- Installation Sealing Kit : Inc. factory fit water resistant reinforcing gasket, for use with waterproofing membranes
 : Optional - AquaeGUARD or AquaeSEAL Waterproof Membranes ~ See Data Sheets
 : Floor gradient 1% > 1.5% to be built into the surrounding floors

MATERIAL

- Channel & Grate : 1.5mm thick 304 High quality Stainless Steel
- Trap : Stainless Steel, with fixed horizontal outlet

CAPACITY

- Waste & Foul Air Trap : Horizontal outlet (33 > 42 Litres/Min) location dependant

Issued - 14 February 2013

INSTALLATION INSTRUCTIONS

- See Separate Sheet : Included in Package

PACKAGING

- Cardboard box : to suit Shower Channel

CONTENTS

Supplied in box:

- Linear Shower Gully with traditional stainless steel grate
- Stainless Steel Foul Air Trap – Fixed Outlet Horizontal connection, DN 50mm
- Water resistant reinforcing collar – fitted to drain chassis
- Cover grate with height adjustable feet
- Installation Feet (concrete floors), & Earthing Tag
- Installation Instructions

SPECIFICATION – “XERO 83” / “XERO 83-Z” 83mm low profile linear floor / drain in 304 S/Steel, fixed trap, reinforcing collar, horizontal outlet accessed by removable & height adjustable grate, for reduced build up concrete floors

Range	Size	ART No.
XERO 83	Ultra Low Profile Linear Shower Drain& Trap, STANDARD Grate, 500 ^{mm}	008 00530
XERO 83	Ultra Low Profile Linear Shower Drain& Trap, STANDARD Grate, 600 ^{mm}	008 00531
XERO 83	Ultra Low Profile Linear Shower Drain& Trap, STANDARD Grate, 700 ^{mm}	008 00532
XERO 83	Ultra Low Profile Linear Shower Drain& Trap, STANDARD Grate, 800 ^{mm}	008 00533
XERO 83	Ultra Low Profile Linear Shower Drain& Trap, STANDARD Grate, 900 ^{mm}	008 00534
XERO 83	Ultra Low Profile Linear Shower Drain& Trap, STANDARD Grate, 1000 ^{mm}	008 00535
XERO 83	Ultra Low Profile Linear Shower Drain& Trap, STANDARD Grate, 1100 ^{mm}	008 00536
XERO 83	Ultra Low Profile Linear Shower Drain& Trap, STANDARD Grate, 1200 ^{mm}	008 00537
XERO 83-Z	Ultra Low Profile Linear Shower Drain& Trap, Upgrade ‘Z’ Grate, 500 ^{mm}	008 00540
XERO 83-Z	Ultra Low Profile Linear Shower Drain& Trap, Upgrade ‘Z’ Grate, 600 ^{mm}	008 00541
XERO 83-Z	Ultra Low Profile Linear Shower Drain& Trap, Upgrade ‘Z’ Grate, 700 ^{mm}	008 00542
XERO 83-Z	Ultra Low Profile Linear Shower Drain& Trap, Upgrade ‘Z’ Grate, 800 ^{mm}	008 00543
XERO 83-Z	Ultra Low Profile Linear Shower Drain& Trap, Upgrade ‘Z’ Grate, 900 ^{mm}	008 00544
XERO 83-Z	Ultra Low Profile Linear Shower Drain& Trap, Upgrade ‘Z’ Grate, 1000 ^{mm}	008 00545
XERO 83-Z	Ultra Low Profile Linear Shower Drain& Trap, Upgrade ‘Z’ Grate, 1100 ^{mm}	008 00546
XERO 83-Z	Ultra Low Profile Linear Shower Drain& Trap, Upgrade ‘Z’ Grate, 1200 ^{mm}	008 00547

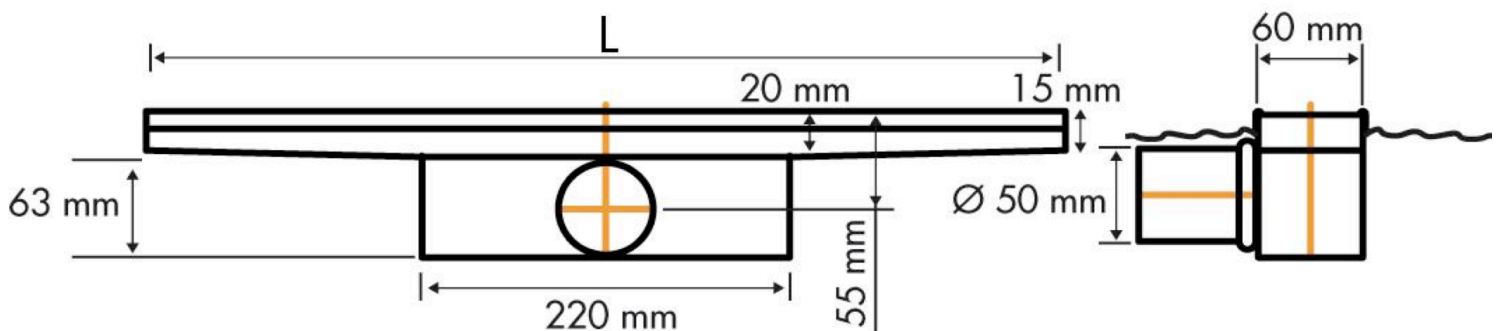

E&OE

We reserve the right to alter & amend specifications without prior notice
 This is not a specification document & does not guarantee performance
 © Bathroom Engineering[™] February 13