

BFM 400 Microphones

Operating Instructions



Manual name: BFM400 Operation Manual

Issue: 9

ECR: 3931

Date of issue: March 2020

© March 2020 Baldwin Boxall Communications Limited

Wealden Industrial Estate
Farningham Road, Jarvis Brook
Crowborough
East Sussex
TN6 2JR
UK

Telephone: +44 (0)1892 664422

Facsimile: +44 (0)1892 663146

Email: mail@baldwinboxall.co.uk

Website: <http://www.baldwinboxall.co.uk>



This equipment has been designed and manufactured to conform to the following EC Standards:

EMC: Emissions EN55032:2015

EMC: Immunity EN50130-4:1995 +A1:1998 +A2:2003

Safety: BS EN 62368-1:2014 +A11:2017

Failure to use the equipment in the manner described in the product literature will invalidate the conformity.

A “Declaration of Conformity” statement to the above standards and a list of auxiliary equipment used for compliance verification is available on request.

Amendment Record _____	v
Proprietary Notice _____	v
Safety Information _____	vi
Comments _____	vi

Introduction

The BFM 400 Microphones Range _____	2
Microphone Options & Features _____	2
Controls & Indicators _____	3
Technical Specification _____	4

Installation

Mounting the Enclosure _____	5
Hardware Switches and Settings _____	6
DVA Message Selection option _____	7
Processor Bypass “All Call” option _____	8
Electrical Connections _____	9

Firmware Configuration

Loading “Default” Values _____	11
Controls & Indicators for Configuration _____	12
Entering “Configuration Mode” _____	12
BFM400 Configuration Table _____	13
Modifying Configuration Settings _____	14
Mic Address & Channel Settings _____	16
Setting Mic Address (using Type 0 protocol) - - - - -	16
Setting Mic Address (using Type 1 protocol) - - - - -	17
Setting Mic Address (Type 2 & 3 protocol) - - - - -	18
Setting or cancelling “Auto-cancel of Selected Zones” _____	19
To Select the Auto-cancel Function - - - - -	19
To De-select the Auto-cancel Function - - - - -	19

Operating Instructions

Controls & Indicators _____	21
To Make an “All Call” announcement _____	22
Using BFM401 Microphone - - - - -	22
Using all other BFM400 Series Microphones - - - - -	22
To Make an Announcement to Selected Zones _____	23
Fault Reporting _____	23
To Broadcast DVA Messages (only available when fitted) _____	24
To Broadcast to All Zones - - - - -	24
To Broadcast to Selected Zones - - - - -	24

AMENDMENT RECORD

Change Note Number	Nature of Amendment	Date of Amendment
2400	Issue 5: BFM401 supplied in Parallel Mode by default	Oct 2010
2808	Issue 6: Factory Default RS485 Protocol changed to "Type 2"	March 2014
3047	Issue 7: Updates post LPCB approval	January 2016
3287	Issue 8: Update to Surveillance options	August 2017
3931	Issue 9: Update to specify number of additional switches	March 2020

PROPRIETARY NOTICE

All data and information contained within this manual is of a proprietary nature with the exclusive title to the same held by Baldwin Boxall Communications Limited. The possession of this manual and the use of the information is, therefore, restricted only to those persons duly authorised by Baldwin Boxall Communications Limited.

Do not reproduce, transcribe, store in a retrieval system or translate into any language, any part of this manual without the prior permission of Baldwin Boxall Communications Limited.

In the interest of continual product development, Baldwin Boxall Communications Limited reserves the right to make changes to product specification without notice or liability. Use of Baldwin Boxall Communications Limited products as critical components in life support systems is not authorised except with express written approval from Baldwin Boxall Communications Limited.

SAFETY INFORMATION

Personnel who install, maintain or repair this equipment must read the safety information below before starting work.

Voltages in excess of 30 Volts RMS or 50 Volts DC are considered Hazardous and in certain circumstances can be lethal.

If Functional Testing, Maintenance, or Repair is to be completed with the Mains Power (and/or battery backup) connected then this should only be undertaken by personnel who are fully aware of the danger involved and who have taken adequate precautions and training.

This Manual contains Warnings, Cautions and Notes.

Warnings describe potential threats to health or life, e.g.



WARNING

Before attempting to remove this component, ensure the Mains Power Supply and Battery Backup have been disconnected.

Cautions describe potential threats to the equipment, e.g.



CAUTION

Notice must be taken of all cautions.
If a Caution is ignored the equipment may be damaged.



CAUTION: ELECTRO-STATIC SENSITIVE DEVICES

Observe the relevant precautions for the protection of Electro-static Sensitive Devices when handling this equipment.

Notes are statements that are useful to the user in the context of a particular section of the manual, e.g.



NOTE: Do not speak into the microphone until the "Speak Now" LED is illuminated.

COMMENTS

Comments regarding the content of this manual are welcome and should be addressed to mail@baldwinboxall.co.uk.

I Introduction

The BFM400 range of intelligent Fire Microphones are designed to provide a wide variety of features to suit any installation.

Figure 1.1 — Typical BFM401 Microphone



The multi - zone Microphones (BFM404 & BFM408) communicate with the main control system via an RS485 communications link.

The single zone BFM401 can be set to connect via RS485 or via a parallel hard - wired connection.

1.1 THE BFM 400 MICROPHONES RANGE

The range of BFM400 microphones include the following types:

Name	No. of Zones
BFM401	1
BFM404	4
BFM408	8

1.2 MICROPHONE OPTIONS & FEATURES

All microphones in the BFM400 range include the following features as standard:

- Housed in a sealed (IP66) lockable steel enclosure,
- All buttons and indicators mounted behind a stylish overlay that allows zone button labels to be inserted and protected
- “Zone Status” indicators show if a zone is currently selected or in use (BFM404 & BFM408)
- “Speak Now” indicator to show the user when a pre-announcement chime has finished
- Simple bar graph display shows the user the current speaking volume to ensure a clear announcement is made
- “Data” and “Power On” indicators to show the unit is functioning correctly
- A Common Fault indicator is included to show the user if a fault is evident on the system
- The Fist Microphone capsule can be set for either Monitored or Un-Monitored use during configuration
- Option to fit upto three flip-top switches to enable DVA Messages to be broadcast.
- Option to fit a “Processor Bypass” hard-wired press to talk switch.

I.3 CONTROLS & INDICATORS

The Front Panel controls and indicators are as follows:

Figure 1.2 — Typical BFM404 Front Panel Controls & Indicators

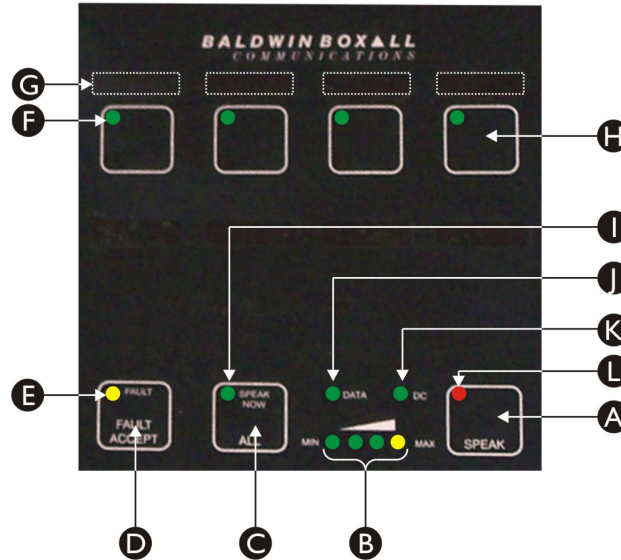

A	"Speak Now" Button	Press button to make an announcement to the selected zone or zones
B	Speech Level Indicator	To ensure clear announcements, the operator should keep the level below the yellow indicator
C	"All Call" Button	Press button to speak to All Zones, regardless of selected zones
D	"Fault Accept" Button	Press button to accept a fault on the system and silence the fault buzzer. This button also acts a "Lamp Test" to check the operation of all indicators
E	System Fault Indicator	Indicates a fault has been detected on the system
F	Zone Status Indicator	When a zone is selected, this indicator will flash to indicate it is selected for the announcement. If the zone is currently busy, the indicator light constantly and not flash. If the zone is busy but also selected, the indicator will flash intermittently
G	Zone Label Area	Area for Zone labels inserted beneath the overlay
H	Zone Button	Press button to select a zone
I	"Speak Now" Indicator	Indicates the pre-announcement chime has finished
J	"Data" Indicator	During normal use, this indicator will flash to show the microphone is communicating with the system
K	"Power On" Indicator	This indicator shows the microphone is receiving power from the system
L	"VA Active" Indicator	Indicates if a zone is currently broadcasting an emergency message or announcement. Note: Busy indicator when BFM401 used in Parallel Mode.

I.4 TECHNICAL SPECIFICATION

Audio	
Nominal Output Level	700mV
Max Output (limiter operating)	1.5V
Output Impedance	400 Ohms
Frequency Response	150Hz - 5KHz
Power Requirement (24V DC)	
BFM401	26mA Standby (30mA Max)
BFM404 & BFM408	35mA Standby (70mA Max)
Serial Data Link	
RS485 9600 Baud	8 bit, Even Parity, 1 Stop Bit
Dimensions	
W x H x D	300mm x 200mm x 82mm
Weight	Approx 3.9Kg
Bezel Overall Size	340mm x 240mm
Bezel Cut out	302mm x 202mm

2 Installation

2.1 MOUNTING THE ENCLOSURE

To gain access to the mounting holes, open the box and remove the 4 off M5x8mm screws securing the inner panel. Carefully remove the panel and detach the CAT5 cable from the termination PCB.

Store the inner panel safely until it can be refitted.

Figure 2.1 — Mounting Hole centres

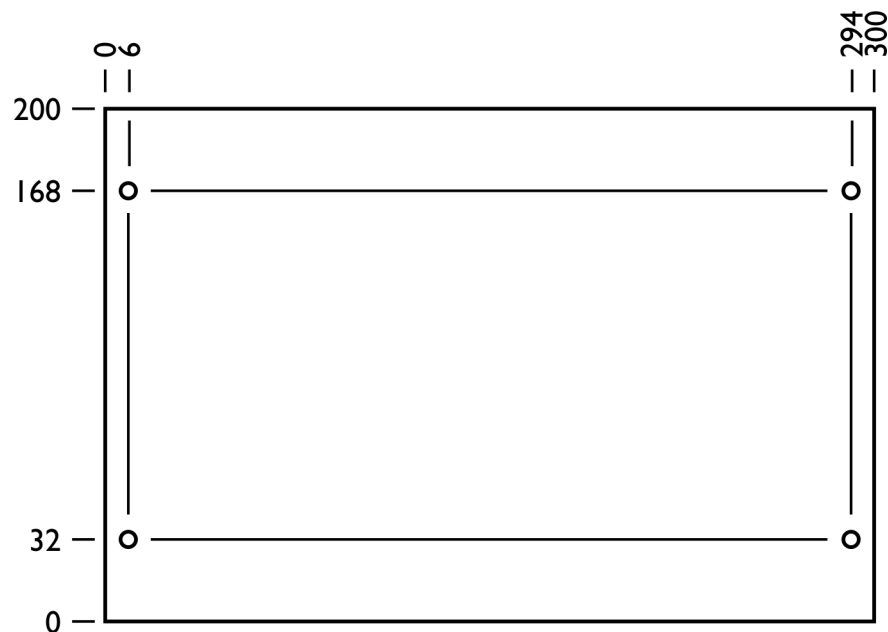

2.2 HARDWARE SWITCHES AND SETTINGS

There are 8 settings that are only available when the inner panel is removed. These are shown in Figure 2.2 (the PCB has been detached from the panel for clarity).

Figure 2.2 — Hardware Settings (BFM401 shown)

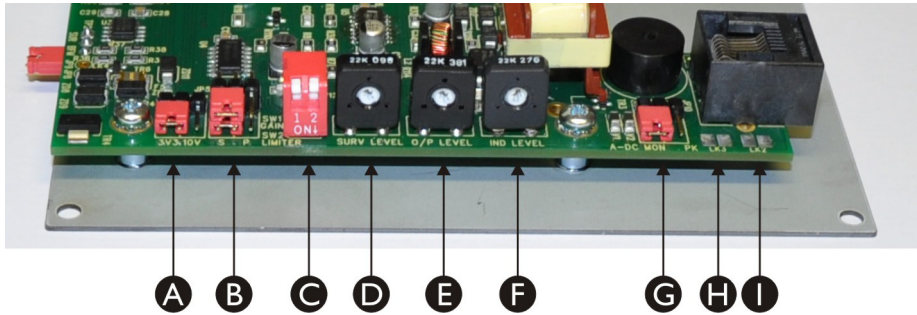

Ident	Marked As...	Function
A	3V3 / 10V	BFM401 parallel (and Processor Bypass All Call) only - see notes below Used to set Access and Access Line Monitoring Level, must match access input used.
B	S / P	BFM401 only - see notes below Fit links in "S" position to use Serial RS485 Communications * Fit links in "P" position to use Parallel Communications
C	Gain / Limiter	SW1.1 - Set to ON to increase the gain by 15dB SW1.2 - Set to "ON" to enable the limiter
D	SURV Level	Sets the 20KHz surveillance level used to monitor the microphone capsule
E	O/P Level	Sets the Output level
F	IND Level	Sets the Indicator sensitivity (factory preset)
G	A-DC	Enables audio output DC monitoring, set to MON to enable monitoring. This option must also be enabled in configuration
H	LK3	Make link if a "Bypass" switch is fitted
I	LK2	Make link to connect "BYPASS" output to +V IN. Can only be used if Bypass switch is not fitted.



NOTE: Monitoring of the Access Line is only applicable to the BFM401 when it is set to "Parallel" Mode or multi-zone BFM microphones with a Bypass "All Call" switch fitted. Monitoring is achieved by placing a Zener Diode between the Access Line and 0V.



NOTE: * The Factory Default setting for BFM401 is "S" position for "Serial" operation.

2.3 DVA MESSAGE SELECTION OPTION

The BFM 400 Microphones include an option to broadcast DVA Messages to either selected or all zones.



NOTE: This is a modification that is normally a factory fitted option.

The front panel of the microphones have extra cutouts behind the overlay to allow extra switches to be fitted.

It is possible to select one of a range of 7 DVA messages by closing the relevant DVA selection point to 0V.

Please refer to the following illustration for connection details.

Figure 2.3 — DVA Message Contacts and Switch Connections

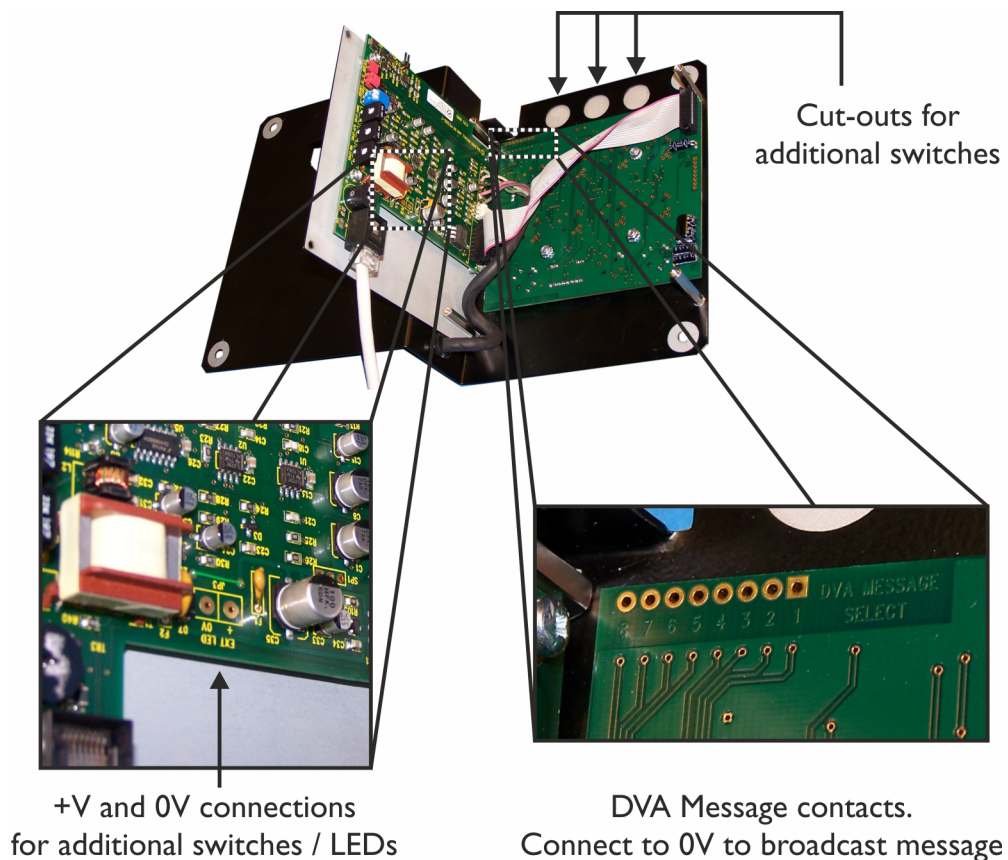

NOTE: If using Type 0 RS485 protocol it is only possible to select DVA Messages 1-7.

With Type 1, 2 or 3 RS485 protocol the range of the DVA messages can be set during configuration. Refer to Section 3.4 for details.

2.4 PROCESSOR BYPASS “ALL CALL” OPTION

It is possible to add an extra hard wired “All Call” processor bypass access switch to the BFM microphones to enable broadcasts in the unlikely event that the router suffers from a processor fault or RS485 network failure.



NOTE: This is a modification that is normally a factory fitted option.



NOTE: The BFM01 can be configured to work in Parallel mode to access an "All Call" bypass input without adding an extra switch.



NOTE: The BFM microphone must be connected to the correct input on the BVRD2M for the processor bypass to operate.

The bypass switch should be connected between JP8 & JP9, a solder bridge should be made across LK3, and LK4 should be carefully drilled out as shown in Figure 2.4.

Figure 2.4 — Connections required for Processor Bypass “All Call” switch

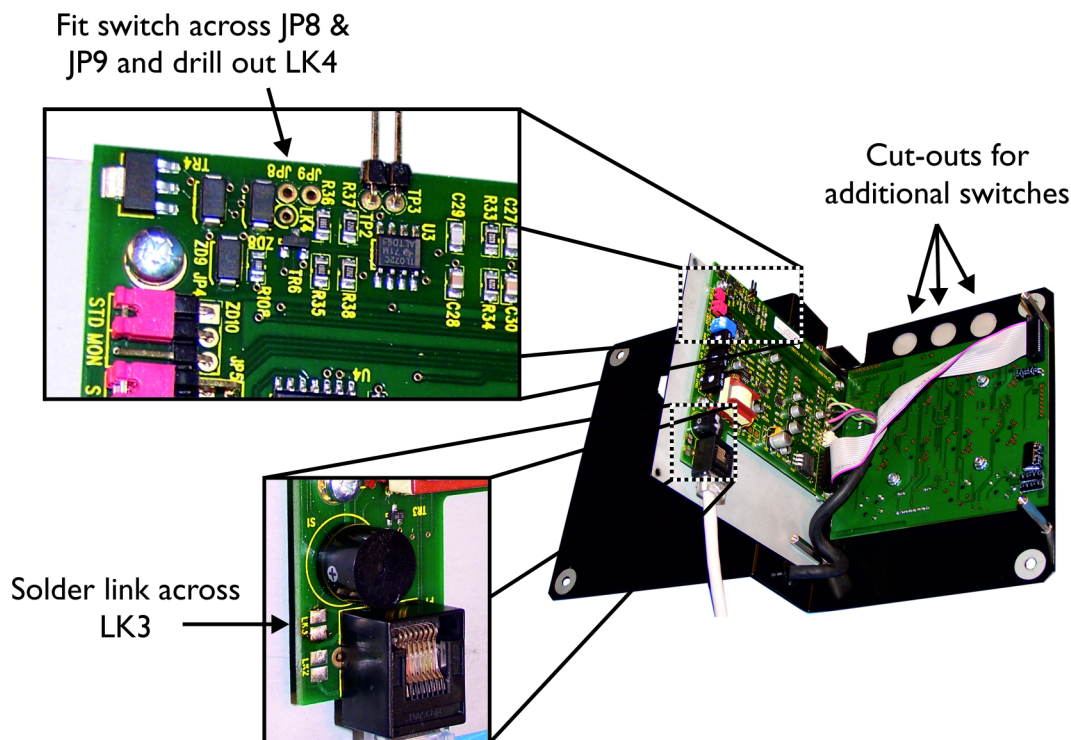

NOTE: The Access Level must be set via JP4 to either 3V3 or 10V which must match the Access Level for the Bypass or CI Input that it is connected to. For further information refer to Figure 2.2.

2.5 ELECTRICAL CONNECTIONS

All electrical connections to the microphone are made using the connector block mounted on the termination PCB.

To avoid the possibility of interference between the Audio and Data we recommend each microphone is connected using two separate 4 core Fire Rated cables, one carrying the Audio pair and the other the Serial Data pair.

Figure 2.5 — Termination PCB



NOTE: The Termination details shown on the PCB are for Serial Connection using RS485 data.

Refer to the table below for Parallel Connection details.

The BFM Factory Default setting is "Serial".

Legend	Serial Connections	Parallel Connections
RS485A	RS485 Transmit	"PTT" (Closes to 0V when PTT is pressed)
RS485B	RS485 Receive	"Busy" (Close to 0V to illuminate Busy LED)
GND	Ground	Ground
+V Supply	+24V Input	+24V Input
0V Supply	0V	0V
GND	Ground	Ground
Audio	Audio Line	Audio Line
Audio	Audio Line	Audio Line
Bypass	Bypass "All Call" Access	Bypass "All Call" Access
GND	Ground	Ground

3 Firmware Configuration

It is necessary to configure the microphone prior to use.

This configuration includes setting system specific options such as enabling the unit to communicate with the system, enabling monitoring of the microphone capsule, and setting the delay before the “Speak Now” indicator illuminates.

3.1 LOADING “DEFAULT” VALUES

To load the default settings (shown in Table 3.1) the following procedure should be used:

1. Remove the RJ45 lead,
2. Press and hold the “Speak” button,
3. Re-connect the RJ45 lead,
4. Release the “Speak” button after 3 seconds.

Default configuration values will then be loaded into the unit.



Note: Before the Microphone can be used the RS485 button allocation data must be downloaded from the BVRD2M.

Press and hold the "FAULT ACCEPT" button for 2 seconds to load the current button allocation data.

It is necessary to download this data after entering Configuration Mode.



Note: If loading of Default values has changed any of the set values it will be necessary to press and hold the "Fault Accept" and "Speak" buttons for 5 seconds in order to accept the new Configuration. Failure to perform this step will result in the Microphone and connected BVRD2M/4 routers indicating a Fault.

3.2 CONTROLS & INDICATORS FOR CONFIGURATION

When in Configuration Mode, the functions of the front panel indicators and controls are as shown in Figure 3.1.

Figure 3.1 — Controls when in Configuration Mode

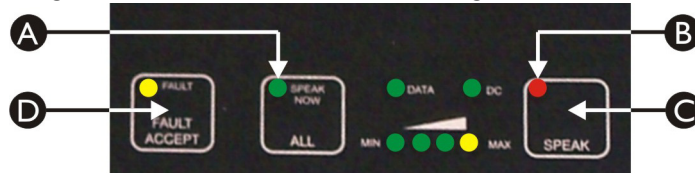

	Original Function	Function in "Configuration" Mode
A	"Speak Now" LED	Flashes to show the current setting of the value or function
B	"VA Active" LED	Flashes to show current position in Configuration Table
C	"Speak" Button	Press to change the setting of the value or function
D	"Fault Accept" Button	Press to step on to the next position in the internal Configuration Table

3.3 ENTERING "CONFIGURATION MODE"

1. Disconnect power from the unit by removing the RJ45 cable.
2. Press and hold the "Fault Accept" button ("D" in Figure 3.1).
3. Connect the RJ45 cable.
4. Release the "Fault Accept" button when the "Busy" indicator (item "B" in Figure 3.1) flashes.
5. The VA Active indicator should now flash once.
This indicates the unit is in Position 1 within the Configuration Table, and the "Speak Now" LED will also flash to indicate the current setting of the "Speak Now Delay" (which is position 1 in the configuration table).
6. The unit is now in Configuration Mode.

3.4 BFM400 CONFIGURATION TABLE

Table 3.1 — Configuration Table

Position	Function / Setting	Available Options	Default Setting
1	"Speak Now" delay (in seconds)	1=0, 2=0.5, 3=1.0 ... 14=6.5, 15=7.0, 16=7.5	1
2	Mic Address	Normally set to match the physical Input in use, (except for Type 1 protocol - see section 3.6.2)	5
3	Channel Select	Set automatically with a value valid for the selected "Mic Address" and protocol in use. Value can be changed if required.	9
4	Number of BVRs on Network		1
5	Mic Surveillance	1=OFF, 2=Capsule Only, 3=Capsule + Audio Path ****, 4=Capsule + Audio Path (No Buzzer)*****	1
6	Message Control	1= All Call, 2=Zonal, 3=All Call unless zone(s) selected	1
7	RS485 Protocol	1=Type 0, 2=Type 1, 3=Type 2 ****, 4=Type 3	3
8	Poll repetition (sec)	1=0.025, 2=0.05, 3=0.075, 4=0.15, 5=0.25, 6=0.5, 7=1.0, 8=1.5, 9= 2.0, 10=2.5, 11=3.0, 12=4.0, 13=5.0, 14=6.0, 15=7.0	7
9	Baud Rate (Hz)	1=1200, 2=2400, 3=4800, 4=9600, 5=19200, 6=38400, 7=57600, 8=115200	4
10	Mic Type (# of zones)	1=single zone (parallel), 2=single zone (serial)*, 3=4&8 zone, 4=16 zone, 5=24 zone, 6=32 zone	N/A
11	# of non poll repeat transmissions	Maximum 7	2
12	Busy indication disable (from) nn	Set lower limit for Busy Indication disable when BGM is used (Type 2 & 3 protocol only) **	5
13	Busy indication disable (to) nn	Set upper limit for Busy Indication disable when BGM is used (Type 2 & 3 protocol only) **	8
14	DVA Message select start #	Set to the required message number to allow DVA messages above 8 to be selected (Type 2 & 3 protocol only) ***	1
15	VA Active I/P Enable	1=Disabled, 2=I/P1 only, 3=I/P1&2 only etc	1
16	VA Active Msg Enable	1=Disabled, 2=Msg1 only, 3=Msg1&2 only etc	1

* The Factory Default setting for all BFM Microphone types is "Serial"

** Since BGM is normally broadcast it is convenient to prevent it from showing a "Busy" condition on the microphone.

*** It is possible to increase the offset to allow messages above 8 to be selected e.g. instead of messages 1 to 8 the unit can be set for messages 4 to 12.

**** The Factory Default RS485 Protocol is "Type 0" for units manufactured prior to Batch # 28351.

***** For Audio Path Monitoring A-DC jumper must be set to MON. Only compatible with BVRD2M or BVRD2M4 firmware versions of V3.0 or higher.



*NOTE: If the Protocol is changed then the Mic Address **MUST** BE RE-ENTERED or the Channel Setting may be incorrect.*

3.5 MODIFYING CONFIGURATION SETTINGS

1. Enter the Configuration Mode as described in Section 3.3.
2. Press the “Fault Accept” button to step through to the required location within the Configuration Table.
3. The “Busy” LED flashes to indicate the location within the table and the “Speak Now” LED flashes to indicate the current setting.
4. To modify the value of the current setting press the “Speak” button the required number of times e.g. if the 3rd value is required press the “Speak” button three times.
The Buzzer will then sound and the “Fault” LED will illuminate for one second to show the value has been accepted.
After a short delay the “Speak Now” LED will flash the revised number of times.
5. To move to the next position within the configuration table press the “Fault Accept” button.
6. To exit from Configuration Mode disconnect the RJ45 cable.
7. When the RJ45 cable is reconnected the microphone will use the new configuration details.
8. After a configuration change has been made the new configuration must be accepted by pressing and holding the “Fault Accept” and “Speak” buttons for 5 seconds. Failure to perform this step will force the Microphone to indicate a fault, the connected BVRD2M or BVRD2M4 router to indicate a “Transmission Fault” and after 1 hour the connected BVRD2M or BVRD2M4 will indicate a “System Fault” which will need to be manually accepted and reset at the router.



Note: Before the Microphone can be used the RS485 button allocation data must be downloaded from the BVRD2M.

Press and hold the "FAULT ACCEPT" button for 2 seconds to load the current button allocation data.

It is necessary to download this data after entering Configuration Mode.



NOTE: If the Protocol is changed then the Mic Address MUST BE RE-ENTERED or the Channel Setting may be incorrect.



NOTE: If a configuration change is made it must be accepted by following step 8 above.

3.6 MIC ADDRESS & CHANNEL SETTINGS

3.6.1 Setting Mic Address (using Type 0 protocol)

The unit must be set to the correct Mic Address to allow monitoring of communications between the mic and the router, and also to identify the mic if the “Listen In” function is selected.

To set the Mic Address, determine the physical input that the microphone is to be connected to, and enter the corresponding value shown in Table 3.2.

The firmware within the microphone uses the Mic Address and the Type 0 protocol to determine the correct “Channel Setting”.

Using the Type 0 protocol (compatible with BVR20 & BVR16M, BVRD2M and CANBUS modules) the Mic Address and Channel Setting may not be the same. This is shown in Table 3.2.

For example, if a microphone is connected to input 5 (BVRD2M) or 9 (BVR20) then the Mic Address should be set to 5.

The Channel Setting would automatically default to 9.

Table 3.2 — Audio Input Channel settings using Type 0 protocol

Mic Address	BVRD2M Physical Input	BVR20 Physical Input	Channel Setting
1	1a	1 (FM 1)	1
2	2a	2 (FM 2)	2
3	3a	3 (FM 3)	3
4	4a	4 (FM 4)	4
5	5a	9 (PM 1)	9
6	6a	10 (PM 2)	10
7	7a	11 (PM 3)	11
8	8a	12 (PM 4)	12
9	9	13 (PM 5)	13
10	10	14 (PM 6)	14
11	11	15 (PM 7)	15
12	12	16 (PM 8)	16



NOTE: *If the Protocol is changed then the Mic Address **MUST** BE RE-ENTERED or the Channel Setting may be incorrect.*

3.6.2 Setting Mic Address (using Type 1 protocol)

The unit must be set to the correct Mic Address to allow monitoring of communications between the mic and the router, and also to identify the mic if the “Listen In” function is selected.

To set the Mic Address, determine the physical input that the microphone is to be connected to, and enter the corresponding value shown in Table 3.3.

The firmware within the microphone uses the Mic Address and the Type 1 protocol to determine the correct “Channel Setting”.

The Type 1 protocol is compatible with BVR20 & BVR16M, BVRD2M and CANBUS modules.

Table 3.3 — Mic Addresses using Type 1 protocol

Mic Address	BVRD2M Physical Input	BVR20 Physical Input	Channel Setting
1	1a	1 (FM 1)	1
2	2a	2 (FM 2)	2
3	3a	3 (FM 3)	3
4	4a	4 (FM 4)	4
5	1b	1 (PM 1)	5
6	2b	2 (PM 2)	6
7	3b	3 (PM 3)	7
8	4b	4 (PM 4)	8
9	9	9 (PM 1)	9
10	10	10 (PM 2)	10
11	11	11 (PM 3)	11
12	12	12 (PM 4)	12
13	13	13 (PM 5)	13
14	14	14 (PM 6)	14
15	15	15 (PM 7)	15
16	16	16 (PM 8)	16



NOTE: *If the Protocol is changed then the Mic Address **MUST BE RE-ENTERED** or the Channel Setting may be incorrect.*

3.6.3 Setting Mic Address (Type 2 & 3 protocol)

The unit must be set to the correct Mic Address to allow monitoring of communications between the mic and the router, and also to identify the mic if the “Listen In” function is selected.

To set the Mic Address, determine the physical input that the microphone is to be connected to, and enter the corresponding value shown in Table 3.4.

The firmware within the microphone uses the Mic Address and the Type 2 protocol to determine the correct “Channel Setting”.

Using the Type 2 protocol (compatible with the BVRD2M and CANBUS modules) the Mic Address and Channel Setting may not be the same. This is shown in Table 3.4.

Table 3.4 — Mic Addresses using Type 2 & 3 protocol

Mic Address	BVRD2M Physical Input	Channel Setting
1	1a	1
2	2a	3
3	3a	5
4	4a	7
5	5a	9
6	6a	11
7	7a	13
8	8a	15
9	9	17
10	10	18
11	11	19
12	12	20
13	13	21
14	14	22
15	15	23
16	16	24
17	17	25
18	18	26
19	19	27
...
67	67	75
68	68	76



NOTE: *If the Protocol is changed then the Mic Address **MUST** BE RE-ENTERED or the Channel Setting may be incorrect.*

3.7 SETTING OR CANCELLING “AUTO-CANCEL OF SELECTED ZONES”

The “Auto-cancel of Selected Zones” function clears selected zones once an announcement has been made and the “Speak” button has been released.

When this function is not selected, the zones selected remain selected after the announcement has been made. This is useful when repeat announcements to the same zones are regularly used.

This option can be set or cancelled at any time without entering the Configuration Mode.



NOTE: The Auto-cancel does not apply to "All Call" announcements made using the "All Call" button.

3.7.1 To Select the Auto-cancel Function

1. Press and hold the “Fault Accept” button,
2. Press the 1st zone key on the master unit,
3. Release the “Fault Accept” button.

3.7.2 To De-select the Auto-cancel Function

1. Press and hold the “Fault Accept” button,
2. Press the 2nd zone key on the master unit,
3. Release the “Fault Accept” button.

4 Operating Instructions

4.1 CONTROLS & INDICATORS

Figure 4.1 — Typical BFM404 Front Panel Controls & Indicators

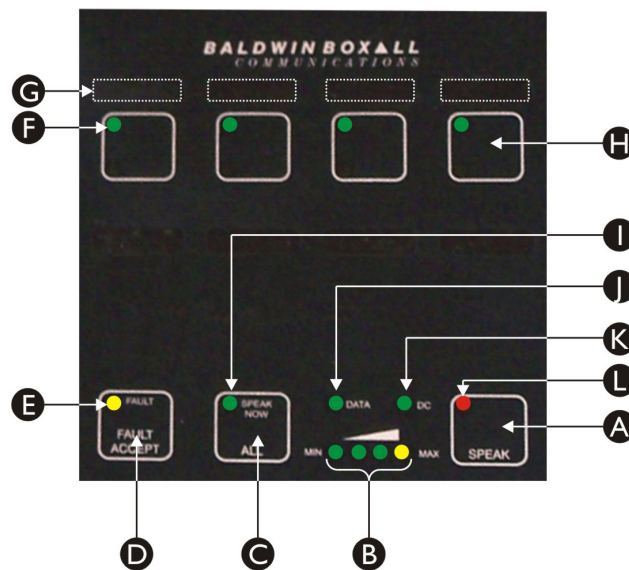

A	"Speak Now" Button	H	Zone Button
B	Speech Level Indicator	I	"Speak Now" Indicator
C	"All Call" Button	J	"Data" Indicator
D	"Fault Accept" Button	K	"Power On" Indicator
E	System Fault Indicator	L	"VA Active" Indicator*
F	Zone Status Indicator		
G	Zone Label Area		

* When a BFM401 microphone is used in Parallel mode this indicator is a busy indicator.

4.2 TO MAKE AN “ALL CALL” ANNOUNCEMENT

4.2.1 Using BFM401 Microphone

1. Pick up the fist microphone.
2. Press the thumbswitch on the microphone or the “SPEAK” button on the front panel and wait for the “SPEAK NOW” Indicator to illuminate.
3. Speak slowly and clearly, ensuring the “MAX” indicator does not illuminate.
4. When the announcement in finished, release the thumbswitch or “SPEAK” Button.
5. Replace the fist microphone.

4.2.2 Using all other BFM400 Series Microphones

1. Pick up the fist microphone.
2. Press the “ALL” button on the front panel.

The “Zone Selected” indicators will illuminate on all zones.



NOTE: If a zone was already busy with another announcement the indicator will still illuminate, however depending on Priority Settings the announcement may not be broadcast to the relevant zone(s).

3. Wait for the “SPEAK NOW” Indicator to illuminate.
Speak slowly and clearly, ensuring the “MAX” indicator does not illuminate.
4. When the announcement in finished, release the “ALL” Button.
5. Replace the fist microphone.

4.3 TO MAKE AN ANNOUNCEMENT TO SELECTED ZONES

1. Press the Zone Select Buttons for the required zones.
The “Zone Status” Indicators will flash to indicate the zone(s) have been selected.



NOTE: If a zone is already busy with another announcement the indicator will flash intermittently.

Depending on Priority Settings the announcement may not be broadcast to the relevant zone(s).

2. Press the thumbswitch or the “SPEAK” button.
The “Zone Status” Indicators will light continuously to show the announcement will be made to the selected zones, however see the above note regarding priority and “BUSY” zones.
3. Wait for the “SPEAK NOW” Indicator to illuminate.
Speak slowly and clearly, ensuring the “MAX” indicator does not illuminate.
4. When the announcement is finished, release the “SPEAK” Button.

4.4 FAULT REPORTING

If a fault is reported on the system the common “FAULT” Indicator will flash and the internal buzzer will sound.

To Accept the Fault and silence the buzzer, press the “FAULT ACCEPT” button.

If the fault is detected on one of the output zones (such as an Amplifier or Loudspeaker Line Fault) the Fault indicator will illuminate in the relevant zone button. Depending on the nature of the fault it could prevent an announcement from being broadcast to the affected zone.

Remedial action should be taken as soon as possible to correct faults as they impair the correct operation of the system.

4.5 TO BROADCAST DVA MESSAGES (ONLY AVAILABLE WHEN FITTED)

The BFM 400 Microphones can have up to three additional switches fitted that enable them to broadcast DVA messages.

These switches are generally “flip-top” switches to prevent accidental operation and are normally a factory fit option.



NOTE: The actual operation of each microphone may differ depending on the switch type (either latching or non-latching), the message settings within the microphone (either All Call, Zonal, or Mixed) and the DVA settings within the BVRD2M.

4.5.1 To Broadcast to All Zones

Press the button for the required message.

The “Zone Status” Indicators will light continuously to show the DVA message is being broadcast to all zones.

4.5.2 To Broadcast to Selected Zones

1. Press the Zone Select Buttons for the required zones.
The “Zone Status” Indicators will flash to indicate the zone(s) have been selected.
2. Press the button for the required message.
The selected “Zone Status” Indicators will light continuously to show the DVA message is being broadcast to the selected zones.