



BDM 400 Microphones

Operating Instructions



Manual name: BDM400 Operation Manual

Issue: 14

ECR: 4049

Date of issue: September 2020

© September 2020 Baldwin Boxall Communications Limited

Wealden Industrial Estate
Farningham Road, Jarvis Brook
Crowborough
East Sussex
TN6 2JR
UK

Telephone: +44 (0)1892 664422

Facsimile: +44 (0)1892 663146

Email: mail@baldwinboxall.co.uk

Website: <http://www.baldwinboxall.co.uk>



This equipment has been designed and manufactured to conform to the following EC Standards:

EMC: Emissions EN55032:2015

EMC: Immunity EN50130-4:1995 +A1:1998 +A2:2003

Safety: BS EN 62368-1:2014 +A11:2017

Failure to use the equipment in the manner described in the product literature will invalidate the conformity.

A “Declaration of Conformity” statement to the above standards and a list of auxiliary equipment used for compliance verification is available on request.

Amendment Record _____	v
Proprietary Notice _____	v
Safety Information _____	vi
Comments _____	vi

Introduction

The BDM 400 Microphones Range _____	2
Microphone Options & Features _____	2
Controls & Indicators _____	3
Technical Specification _____	4

Installation

BMS8 Termination Box _____	5
Hardware Switches and Settings _____	6
DVA Message Selection option _____	7
Processor Bypass “All Call” option _____	8
Cable Identification _____	9
Colour Code for units using Serial Comms - - - - -	9
Colour Code for BDM401 in “Parallel” Mode - - - - -	9
Colour Code for Processor Bypass switch - - - - -	9
Wall Mounting Option (BDM3WB) _____	10
Installation Instructions - - - - -	10

Firmware Configuration

Loading “Default” Values _____	13
Controls & Indicators for Configuration _____	14
Entering “Configuration Mode” _____	14
BDM400 Configuration Table _____	16
Modifying Configuration Settings _____	17
Mic Address & Channel Settings _____	19
Setting Mic Address (using Type 0 protocol) - - - - -	19
Setting Mic Address (using Type 1 protocol) - - - - -	20
Setting Mic Address (Type 2 & 3 protocol) - - - - -	21

Setting or cancelling “Auto-cancel of Selected Zones” _____	22
To Select the Auto-cancel Function - - - - -	22
To De-select the Auto-cancel Function - - - - -	22

Operating Instructions

Controls & Indicators _____	23
To Make an “All Call” announcement _____	24
Using BDM401 Microphone- - - - -	24
Using all other BDM400 Series Microphones - - - - -	24
To Make an Announcement to Selected Zones _____	25
Fault Reporting _____	25
To Broadcast DVA Messages (only available when fitted) _____	26
To Broadcast to All Zones - - - - -	26
To Broadcast to Selected Zones - - - - -	26

AMENDMENT RECORD

Change Note Number	Nature of Amendment	Date of Amendment
2808	Issue 10: Factory Default RS485 Protocol changed to "Type 2"	March 2014
3047	Issue 11: Updates post LPCB approval	January 2016
3287	Issue 12: Update to Surveillance options	August 2017
3931	Issue 13: Clarify quantity of additional switches are available	March 2020
4049	Issue 14: Default setting changed to Serial Interface	Sept 2020

PROPRIETARY NOTICE

All data and information contained within this manual is of a proprietary nature with the exclusive title to the same held by Baldwin Boxall Communications Limited. The possession of this manual and the use of the information is, therefore, restricted only to those persons duly authorised by Baldwin Boxall Communications Limited.

Do not reproduce, transcribe, store in a retrieval system or translate into any language, any part of this manual without the prior permission of Baldwin Boxall Communications Limited.

In the interest of continual product development, Baldwin Boxall Communications Limited reserves the right to make changes to product specification without notice or liability. Use of Baldwin Boxall Communications Limited products as critical components in life support systems is not authorised except with express written approval from Baldwin Boxall Communications Limited.

SAFETY INFORMATION

Personnel who install, maintain or repair this equipment must read the safety information below before starting work.

Voltages in excess of 30 Volts RMS or 50 Volts DC are considered Hazardous and in certain circumstances can be lethal.

If Functional Testing, Maintenance, or Repair is to be completed with the Mains Power (and/or battery backup) connected then this should only be undertaken by personnel who are fully aware of the danger involved and who have taken adequate precautions and training.

This Manual contains Warnings, Cautions and Notes.

Warnings describe potential threats to health or life, e.g.



WARNING

Before attempting to remove this component, ensure the Mains Power Supply and Battery Backup have been disconnected.

Cautions describe potential threats to the equipment, e.g.



CAUTION

Notice must be taken of all cautions.
If a Caution is ignored the equipment may be damaged.



CAUTION: ELECTRO-STATIC SENSITIVE DEVICES

Observe the relevant precautions for the protection of Electro-static Sensitive Devices when handling this equipment.

Notes are statements that are useful to the user in the context of a particular section of the manual, e.g.



NOTE: Do not speak into the microphone until the "Speak Now" LED is illuminated.

COMMENTS

Comments regarding the content of this manual are welcome and should be addressed to mail@baldwinboxall.co.uk.

I Introduction

The BDM 400 range of intelligent Microphones are designed to provide a wide variety of features to suit any installation.

Figure 1.1 — Typical BDM416 Microphone



The Microphones communicate with the main control system via an RS485 communications link, and as the only connection required on each unit is made using a standard RJ45 Network cable connection (carrying both Audio and Serial Data) system wiring is considerably reduced.

I.1 THE BDM 400 MICROPHONES RANGE

The range of BDM400 microphones include the following types:

Name	No. of Zones
BDM401	1
BDM404	4
BDM408	8
BDM416	16
BDM424	24
BDM432	32

I.2 MICROPHONE OPTIONS & FEATURES

All microphones in the BDM400 range include the following features as standard:

- Ergonomic design with all buttons and indicators mounted behind a stylish overlay that allows zone button labels to be inserted and protected
- The Dynamic Cardioid microphone capsule can be set for either Monitored or Un-Monitored use during configuration
- “Zone Status” indicators show if a zone is currently selected or in use
- “Speak Now” indicator to show the user when a pre-announcement chime has finished
- Simple bar graph display shows the user the current speaking volume to ensure a clear announcement is made
- “Data” and “Power On” indicators to show the unit is functioning correctly
- A Common Fault indicator is included to show the user if a fault is evident on the system
- Optional fliptop switches to enable DVA Message broadcast. Please note the maximum number of switches is as follows:
BDM401 / BDM404 / BDM408 - 3 switches,
BDM416 - 7 switches,
BDM424 - 9 switches.

I.3 CONTROLS & INDICATORS

The Front Panel controls and indicators are as follows:

Figure 1.2 — Typical BDM404 Front Panel Controls & Indicators

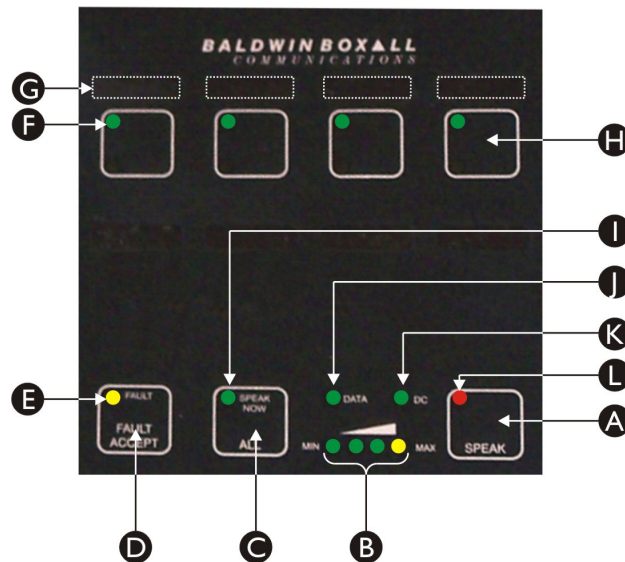

A	"Speak" Button	Press button to make an announcement to the selected zone or zones
B	Speech Level Indicator	To ensure clear announcements, the operator should keep the level below the yellow indicator
C	"All Call" Button	Press button to speak to All Zones, regardless of selected zones
D	"Fault Accept" Button	Press button to accept a fault on the system and silence the fault buzzer. This button also acts a "Lamp Test" to check the operation of all indicators
E	System Fault Indicator	Indicates a fault has been detected on the system
F	Zone Status Indicator	When a zone is selected, this indicator will flash to indicate it is selected for the announcement. If the zone is currently busy, the indicator lights constantly and does not flash. If the zone is busy but also selected, the indicator will flash intermittently
G	Zone Label Area	Area for Zone labels inserted beneath the overlay
H	Zone Button	Press button to select a zone
I	"Speak Now" Indicator	Indicates the pre-announcement chime has finished
J	"Data" Indicator	During normal use, this indicator will flash.
K	"Power On" Indicator	This indicator shows the microphone is receiving power from the system
L	"VA Active" Indicator	Indicates if a zone is currently broadcasting an emergency message or announcement. Note: Busy indicator when BDM401 used in Parallel Mode.

I.4 TECHNICAL SPECIFICATION

Audio	
Nominal Output Level	700mV
Max Output (limiter operating)	1.5V
Output Impedance	400 Ohms
Frequency Response	250Hz - 10KHz
Power Requirement (24V DC)	
BDM401	26mA Standby (30mA Max)
BDM404 & BDM408	35mA Standby (70mA Max)
BDM416	42mA Standby (108mA Max)
BDM424	52mA Standby (150mA Max)
BDM432	62mA Standby (200mA Max)
Serial Data Link	
RS485 9600 Baud	8 bit, Even Parity, 1 Stop Bit
Dimensions (W x H x D)	
BDM401 / 04 / 8	148mm x 48mm x 177mm
BDM316	275mm x 48mm x 177mm
BDM424	398mm x 48mm x 177mm
BDM432	523mm x 48mm x 177mm

2 Installation

2.1 BMS8 TERMINATION BOX

The BDM 400 Microphones are designed to allow simple installation using the minimum of system cabling.

All microphones use a single RJ45 (CAT5 network) connection, which is usually terminated to a local wall mounted BMS8 Termination box.

Figure 2.1 — Typical BMS8 Termination Box

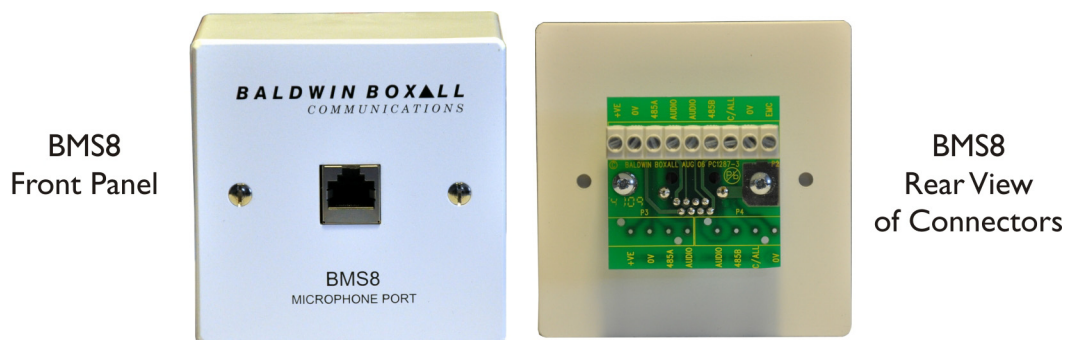

CAUTION

The BMS8 Termination Box has a standard RJ45 socket to allow use of a standard CAT5 network cable to connect to the microphone.

Care must be taken to ensure this socket is not used for any other equipment since it may be damaged if connected.

2.2 HARDWARE SWITCHES AND SETTINGS

Depending on model, there are up to 9 settings that are available by removing the right hand side panel of the microphone. These are shown in Figure 2.2.

Figure 2.2 — Hardware Settings

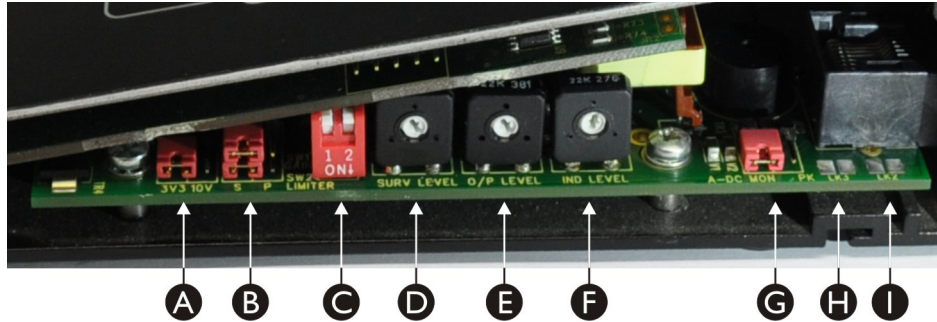

Ident	Marked As...	Function
A	3V3 / 10V	BDM401 parallel (and Processor Bypass All Call) only - see notes below Used to set Access Level and Access Line Monitoring Level, must match access input used.
B	S / P	BDM401 only - see notes below Fit link in "P" position to use Parallel Communications Fit link in "S" position to use Serial RS485 Communications *
C	Gain / Limiter	SW1.1 - Set to ON to increase the gain by 15dB SW1.2 - Set to "ON" to enable the limiter
D	SURV Level	Sets the 20KHz surveillance level used to monitor the microphone capsule
E	O/P Level	Sets the Output level
F	IND Level	Sets the Indicator sensitivity (factory preset)
G	A-DC	Enables audio output DC monitoring, set to MON to enable monitoring. This option must also be enabled in configuration
H	LK3	Make link if a "Bypass" switch is fitted
I	LK2	Make link to connect spare RJ45 conductor to +V IN. This may be useful in installations with long cable runs. <i>Can only be used if Bypass switch is not fitted.</i>



NOTE: Monitoring of the Access Line is applicable to the BDM401 when it is set to "Parallel" Mode or multi-zone BDM microphones with a Bypass "All Call" switch fitted. Monitoring is achieved by placing a Zener Diode between the Access Line and 0V. Default is 3V3.



*NOTE: * The Factory Default setting for BDM401 is "S" position for "Serial RS485" operation.*

2.3 DVA MESSAGE SELECTION OPTION

The BDM 400 Microphones include an option to broadcast DVA Messages to either selected or all zones.



NOTE: This is a modification that is normally a factory fitted option.

The top panel of the microphones have extra cutouts behind the overlay to allow extra switches to be fitted.

The BDM401, 404 and 408 microphones have three cutouts and the BDM416 has seven.

It is possible to select one of a range of 7 DVA messages by closing the relevant DVA selection point to 0V.

Please refer to the following illustration for connection details.

Figure 2.3 — DVA Message Contacts and Switch Connections

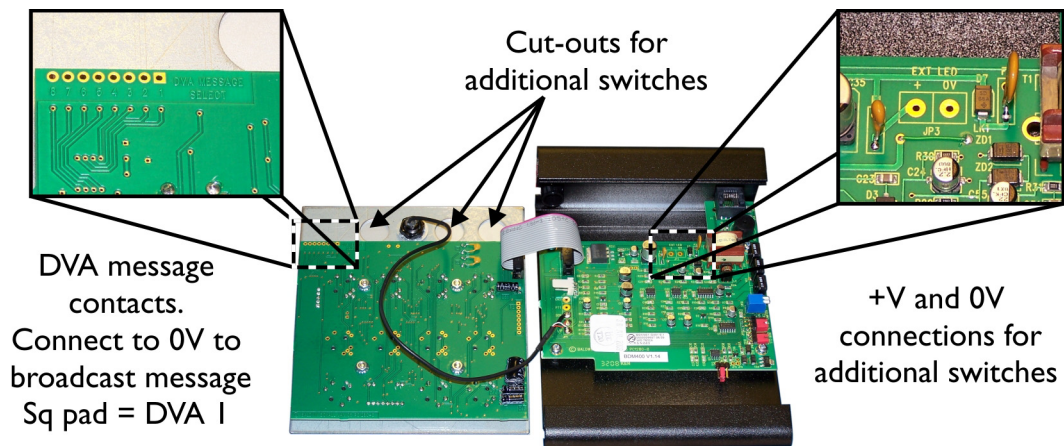

CAUTION

It is important to ensure switch terminals do not short out on the chassis due to the limited height within the body of the microphone.

If required, please contact our Technical Sales department for details of suitable switches.



Note: If using Type 0 RS485 protocol it is only possible to select DVA Messages 1-7.

With Type 1, 2 or 3 RS485 protocol the range of the DVA messages can be set during configuration. Refer to Section 3.4 for details.

2.4 PROCESSOR BYPASS “ALL CALL” OPTION

It is possible to add an extra hard wired “All Call” processor bypass access switch to the BDM microphones to enable broadcasts in the unlikely event that the router suffers from a processor fault or RS485 network failure.



NOTE: This is a modification that is normally a factory fitted option.



NOTE: The BDM401 in Parallel mode can access an "All Call" bypass input without adding an extra switch.



NOTE: The BDM microphone must be connected to the correct input on the BVRD2M for the processor bypass to operate.

The bypass switch should be connected between JP8 & JP9, a solder bridge should be made across LK3, and LK4 should be carefully drilled out as shown in Figure 2.4.

Figure 2.4 — Connections required for Processor Bypass “All Call” switch

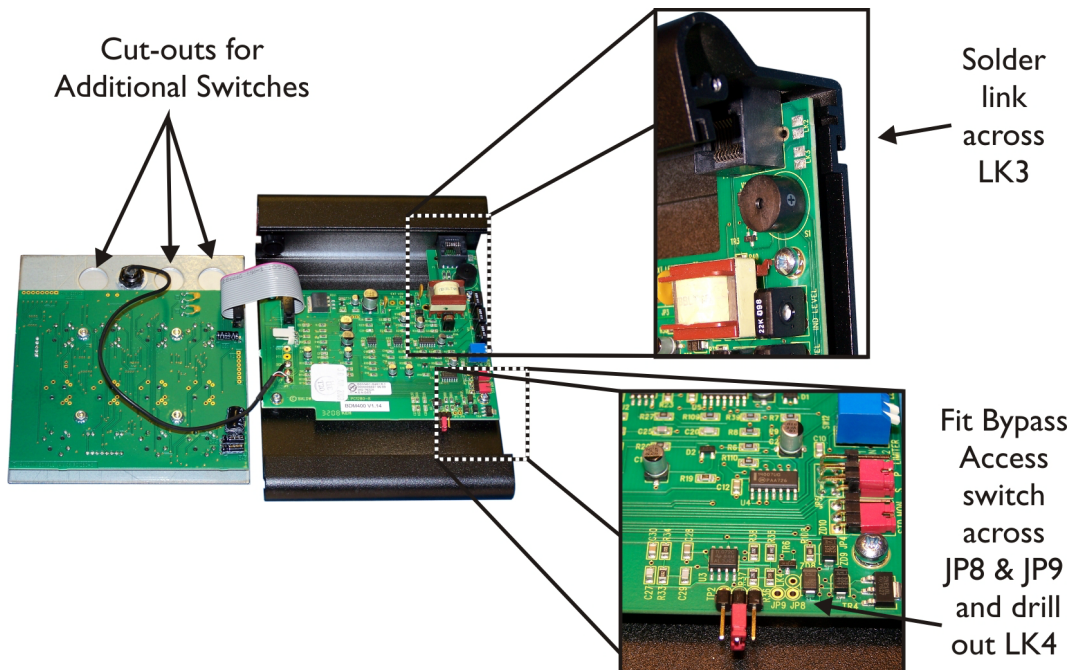

NOTE: The Access Level must be set via JP4 to either 3V3 or 10V which must match the Access Level of the Bypass or CI input that it is connected to. For further information refer to Figure 2.2.

2.5 CABLE IDENTIFICATION

2.5.1 Colour Code for units using Serial Comms

Function	Pin #	Cable Colour
+V DC	1	Orange / White
0V	2 & 8	Orange & Brown
Data "A"	3	Green / White
Audio	4	Blue
Audio	5	Blue / White
Data "B"	6	Green
Spare	7	Brown / White (Not used by default)



NOTE: The table above is correct for all types of microphone except when the BDM401 is used in "Parallel" Mode without RS485 comms.

2.5.2 Colour Code for BDM401 in "Parallel" Mode

Function	Pin #	Cable Colour
+V DC	1	Orange / White
0V	2 & 8	Orange & Brown
"PTT"	3	Green / White (Closes to 0v when PTT is pressed)
Audio	4	Blue
Audio	5	Blue / White
"Busy"	6	Green (Close to 0V to illuminate "Busy" LED)
Spare	7	Brown / White (Not used by default)



NOTE: The BDM401 Factory Default setting is "Serial".

2.5.3 Colour Code for Processor Bypass switch

The colour code for multi zone Microphones with a Bypass switch fitted are as shown in Section 2.5.1.

The Bypass Access is on Pin 7 (Brown / White).

2.6 WALL MOUNTING OPTION (BDM3WB)

The Wall Mounting option (product code BDM3WB) allows any of the BDM 400 Microphones to be wall mounted.

The BDM3WB is separate back plate that is secured to the wall.

The overall dimensions and the positions of the mounting holes of the back plate are shown in Figure 2.5

Figure 2.5 — Mounting hole positions on BDM3WB

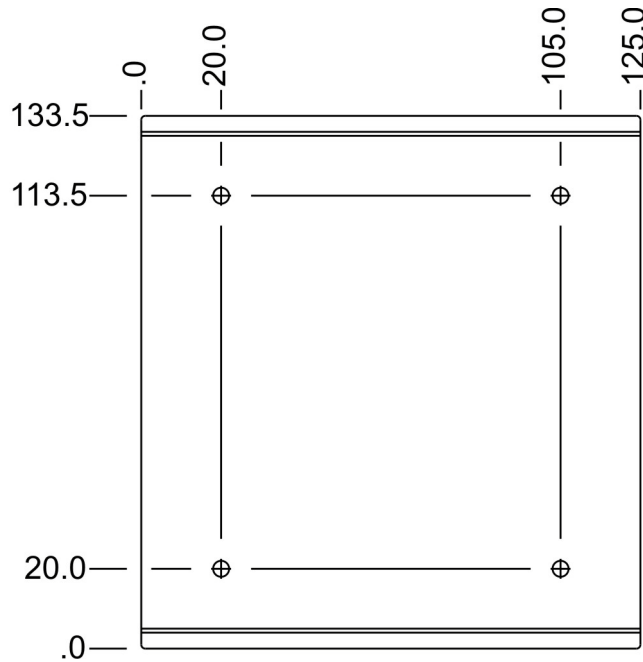

2.6.1 Installation Instructions

1. Mount the back plate on the wall.
2. Remove one of the side panels of the microphone.
3. Slide the microphone over the back plate.

Ensure both the upper and lower raised edges of the back plate slide securely into the corresponding mounting slots in the extrusion of the base of the unit.

These slots are shown in Figure 2.6.

Figure 2.6 — Mounting slots for Wall Mounting bracket

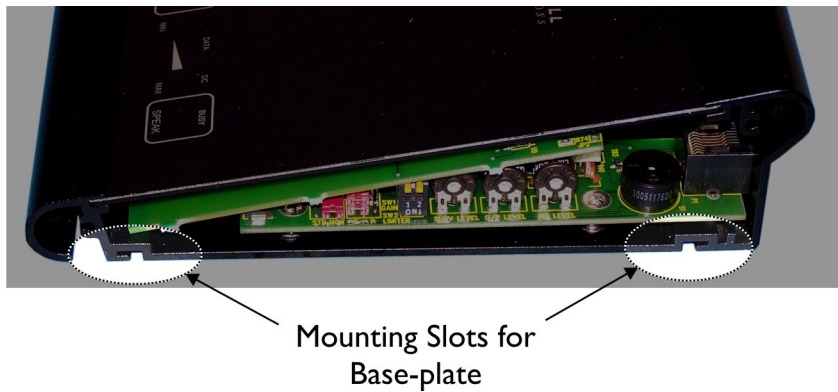

4. Refit the side panel on the microphone.

The side panel secures the microphone onto the back plate.

For wall mounting larger microphones (such as the BDM416, BDM424 or BDM432) two mounting plates can be placed side by side.

3 Firmware Configuration

It is necessary to configure the microphone prior to use.

This configuration includes setting system specific options such as enabling the unit to communicate with the system, enabling monitoring of the microphone capsule, and setting the delay before the “Speak Now” indicator illuminates.

3.1 LOADING “DEFAULT” VALUES

To load the default settings (shown in Table 3.1) the following procedure should be used:

1. Remove the RJ45 lead,
2. Press and hold the “Speak” button,
3. Re-connect the RJ45 lead,
4. Release the “Speak” button after 3 seconds.

Default configuration values will then be loaded into the unit.



Note: Before the Microphone can be used the RS485 button allocation data must be downloaded from the BVRD2M.

Press and hold the "FAULT ACCEPT" button for 2 seconds to load the current button allocation data.

It is necessary to download this data after entering Configuration Mode.



*Note: If loading of Default values has changed any of the set values it will be necessary to press and hold the "Fault Accept" and "Speak" buttons for 5 seconds in order to accept the new Configuration. Failure to perform this step will result in the Microphone and connected BVRD2M/4 routers initially indicating a "Transmission Fault" and after a period of 1 hour indicating a "System Fault".
A "System Fault" must be reset at all connected BVRD2M/4 routers.*

3.2 CONTROLS & INDICATORS FOR CONFIGURATION

When in Configuration Mode, the functions of the front panel indicators and controls are as shown in Figure 3.1.

Figure 3.1 — Controls when in Configuration Mode



	Original Function	Function in "Configuration" Mode
A	"Speak Now" LED	Flashes to show the current setting of the value or function
B	"VA Active" LED	Flashes to show the current position in the Configuration Table
C	"Speak" Button	Press to change the setting of the value or function
D	"Fault Accept" Button	Press to step on to the next position in the internal Configuration Table

3.3 ENTERING "CONFIGURATION MODE"

1. Disconnect power from the unit by removing the RJ45 cable.
2. Press and hold the "Fault Accept" button ("D" in Figure 3.1).
3. Connect the RJ45 cable.
4. Release the "Fault Accept" button when the "VA Active" indicator (item "B" in Figure 3.1) flashes.

5. The VA Active indicator should now flash once.
This indicates the unit is in Position 1 within the Configuration Table, and the “Speak Now” LED will also flash to indicate the current setting of the “Speak Now Delay” (which is position 1 in the configuration table).
6. The unit is now in Configuration Mode.

3.4 BDM400 CONFIGURATION TABLE

Table 3.1 — Configuration Table

Position	Function / Setting	Available Options	Default Setting
1	"Speak Now" delay (in seconds)	1=0, 2=0.5, 3=1.0 ... 14=6.5, 15=7.0, 16=7.5	1
2	Mic Address	Normally set to match the physical Input in use, (except for Type 1 protocol - see section 3.6.2)	5
3	Channel Select	Set automatically with a value valid for the selected "Mic Address" and protocol in use. Value can be changed if required.	9
4	Number of BVRs on network		1
5	Mic Surveillance	1=OFF, 2=Capsule Only, 3=Capsule + Audio Path ****, 4=Capsule + Audio Path (No Buzzer)*****	1
6	Message Control	1= All Call, 2=Zonal, 3=All Call unless zone(s) selected	1
7	RS485 Protocol	1=Type 0, 2=Type 1, 3=Type 2 ****, 4=Type 3	3
8	Poll repetition (sec)	1=0.025, 2=0.05, 3=0.075, 4=0.15, 5=0.25, 6=0.5, 7=1.0, 8=1.5, 9= 2.0, 10=2.5, 11=3.0, 12=4.0, 13=5.0, 14=6.0, 15=7.0	7
9	Baud Rate (Hz)	1=1200, 2=2400, 3=4800, 4=9600, 5=19200, 6=38400, 7=57600, 8=115200	4
10	Mic Type (# of zones)	1=single zone (parallel), 2=single zone (serial) *, 3=4&8 zone, 4=16 zone, 5=24 zone, 6=32 zone	N/A
11	# of non poll repeat transmissions	Maximum 7	2
12	Busy indication disable (from) nn	Set lower limit for Busy Indication disable when BGM is used (Type 2 & 3 protocol only) **	5
13	Busy indication disable (to) nn	Set upper limit for Busy Indication disable when BGM is used (Type 2 & 3 protocol only) **	8
14	DVA Message select start #	Set to the required message number to allow DVA messages above 8 to be selected (Type 2 & 3 protocol only) ***	1
15	VA Active I/P Enable	1=Disabled, 2=I/PI only, 3=I/PI&2 only etc	3
16	VA Active Msg Enable	1=Disabled, 2=Msg1 only, 3=Msg 1&2 only etc	3

* The Factory Default setting for BDM401 is "Serial"

** Since BGM is normally broadcast it is convenient to prevent it from showing a "Busy" condition on the microphone.

*** It is possible to increase the offset to allow selection of messages above 8 to be selected e.g. instead of messages 1 to 8 the unit can be set for messages 4 to 12.

**** The Factory Default RS485 Protocol is "Type 0" for units manufactured prior to Batch # 28351.

***** For Audio Path Monitoring A-DC jumper must be set to MON. Only compatible with BVRD2M or BVRD2M4 firmware versions of V3.0 or higher.



*NOTE: If the Protocol is changed then the Mic Address **MUST BE RE-ENTERED** or the Channel Setting may be incorrect.*

3.5 MODIFYING CONFIGURATION SETTINGS

1. Enter the Configuration Mode as described in Section 3.3.
2. Press the “Fault Accept” button to step through to the required location within the Configuration Table.
3. The “Busy” LED flashes to indicate the location within the table and the “Speak Now” LED flashes to indicate the current setting.
4. To modify the value of the current setting press the “Speak” button the required number of times e.g. if the 3rd value is required press the “Speak” button three times.
The Buzzer will then sound and the “Fault” LED will illuminate for one second to show the value has been accepted.
After a short delay the “Speak Now” LED will flash the revised number of times.
5. To move to the next position within the configuration table press the “Fault Accept” button.
6. To exit from Configuration Mode disconnect the RJ45 cable.
7. When the RJ45 cable is reconnected the microphone will use the new configuration details.
8. After a configuration change has been made the new configuration must be accepted by pressing and holding the "Fault Accept" and "Speak" buttons for 5 seconds. Failure to perform this step will force the Microphone to indicate a fault, the connected BVRD2M or BVRD2M4 router to indicate a "Transmission Fault" and after 1 hour the connected BVRD2M or BVRD2M4 will indicate a "System Fault" which will need to manually accepted and reset at the router.



Note: Before the Microphone can be used the RS485 button allocation data must be downloaded from the BVRD2M.

Press and hold the "FAULT ACCEPT" button for 2 seconds to load the current button allocation data.

It is necessary to download this data after entering Configuration Mode.



NOTE: If the Protocol is changed then the Mic Address *MUST BE RE-ENTERED* or the Channel Setting may be incorrect.



NOTE: If a configuration change is made it must be accepted by following step 8 above.

3.6 MIC ADDRESS & CHANNEL SETTINGS

3.6.1 Setting Mic Address (using Type 0 protocol)

The unit must be set to the correct Mic Address to allow monitoring of communications between the mic and the router, and also to identify the mic if the “Listen In” function is selected.

To set the Mic Address, determine the physical input that the microphone is to be connected to, and enter the corresponding value shown in Table 3.2.

The firmware within the microphone uses the Mic Address and the Type 0 protocol to determine the correct “Channel Setting”.

Using the Type 0 protocol (compatible with BVR20 & BVR16M, BVRD2M and CANBUS modules) the Mic Address and Channel Setting may not be the same. This is shown in Table 3.2.

For example, if a microphone is connected to input 5 (BVRD2M) or 9 (BVR20) then the Mic Address should be set to 5.

The Channel Setting would automatically default to 9.

Table 3.2 — Audio Input Channel settings using Type 0 protocol

Mic Address	BVRD2M Physical Input	BVR20 Physical Input	Channel Setting
1	1a	1 (FM 1)	1
2	2a	2 (FM 2)	2
3	3a	3 (FM 3)	3
4	4a	4 (FM 4)	4
5	5a	9 (PM 1)	9
6	6a	10 (PM 2)	10
7	7a	11 (PM 3)	11
8	8a	12 (PM 4)	12
9	9	13 (PM 5)	13
10	10	14 (PM 6)	14
11	11	15 (PM 7)	15
12	12	16 (PM 8)	16



NOTE: If the Protocol is changed then the Mic Address **MUST BE RE-ENTERED** or the Channel Setting may be incorrect.

3.6.2 Setting Mic Address (using Type I protocol)

The unit must be set to the correct Mic Address to allow monitoring of communications between the mic and the router, and also to identify the mic if the “Listen In” function is selected.

To set the Mic Address, determine the physical input that the microphone is to be connected to, and enter the corresponding value shown in Table 3.3.

The firmware within the microphone uses the Mic Address and the Type 1 protocol to determine the correct “Channel Setting”.

The Type 1 protocol is compatible with BVR20 & BVR16M, BVRD2M and CANBUS modules.

Table 3.3 — Mic Addresses using Type I protocol

Mic Address	BVRD2M Physical Input	BVR20 Physical Input	Channel Setting
1	1a	1 (FM 1)	1
2	2a	2 (FM 2)	2
3	3a	3 (FM 3)	3
4	4a	4 (FM 4)	4
5	1b	1 (PM 1)	5
6	2b	2 (PM 2)	6
7	3b	3 (PM 3)	7
8	4b	4 (PM 4)	8
9	9	9 (PM 1)	9
10	10	10 (PM 2)	10
11	11	11 (PM 3)	11
12	12	12 (PM 4)	12
13	13	13 (PM 5)	13
14	14	14 (PM 6)	14
15	15	15 (PM 7)	15
16	16	16 (PM 8)	16



NOTE: *If the Protocol is changed then the Mic Address **MUST BE RE-ENTERED** or the Channel Setting may be incorrect.*

3.6.3 Setting Mic Address (Type 2 & 3 protocol)

The unit must be set to the correct Mic Address to allow monitoring of communications between the mic and the router, and also to identify the mic if the “Listen In” function is selected.

To set the Mic Address, determine the physical input that the microphone is to be connected to, and enter the corresponding value shown in Table 3.4.

The firmware within the microphone uses the Mic Address and the Type 2 protocol to determine the correct “Channel Setting”.

Using the Type 2 protocol (compatible with the BVRD2M and CANBUS modules) the Mic Address and Channel Setting may not be the same. This is shown in Table 3.4.

Table 3.4 — Mic Addresses using Type 2 & 3 protocol

Mic Address	BVRD2M Physical Input	Channel Setting
1	1a	1
2	2a	3
3	3a	5
4	4a	7
5	5a	9
6	6a	11
7	7a	13
8	8a	15
9	9	17
10	10	18
11	11	19
12	12	20
13	13	21
14	14	22
15	15	23
16	16	24
17	17	25
18	18	26
19	19	27
...
67	67	75
68	68	76



NOTE: *If the Protocol is changed then the Mic Address **MUST BE RE-ENTERED** or the Channel Setting may be incorrect.*

3.7 SETTING OR CANCELLING “AUTO-CANCEL OF SELECTED ZONES”

The “Auto-cancel of Selected Zones” function clears selected zones once an announcement has been made and the “Speak” button has been released.

When this function is not selected, the zones selected remain selected after the announcement has been made. This is useful when repeat announcements to the same zones are regularly used.

This option can be set or cancelled at any time without entering the Configuration Mode.



NOTE: The Auto-cancel does not apply to "All Call" announcements made using the "All Call" button.

3.7.1 To Select the Auto-cancel Function

1. Press and hold the “Fault Accept” button,
2. Press the 1st zone key on the master unit,
3. Release the “Fault Accept” button.

3.7.2 To De-select the Auto-cancel Function

1. Press and hold the “Fault Accept” button,
2. Press the 2nd zone key on the master unit,
3. Release the “Fault Accept” button.

4 Operating Instructions

4.1 CONTROLS & INDICATORS

Figure 4.1 — Typical BDM404 Front Panel Controls & Indicators

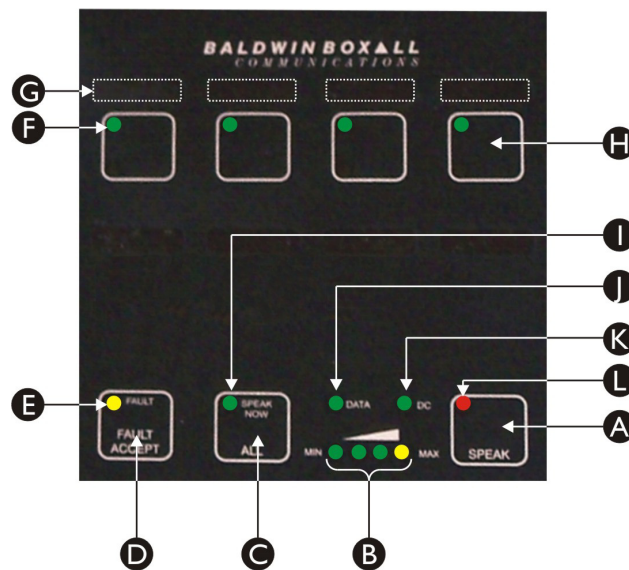

A	"Speak" Button	G	Zone Label Area
B	Speech Level Indicator	H	Zone Button
C	"All Call" Button	I	"Speak Now" Indicator
D	"Fault Accept" Button	J	"Data" Indicator
E	System Fault Indicator	K	"Power On" Indicator
F	Zone Status Indicator	L	"VA Active" Indicator *

*When a BDM401 microphone is used in Parallel mode this indicator is a "Busy" indicator.

4.2 TO MAKE AN “ALL CALL” ANNOUNCEMENT

4.2.1 Using BDM401 Microphone

1. Press the “SPEAK” button and wait for the “SPEAK NOW” Indicator to illuminate.
2. Speak slowly and clearly, ensuring the “MAX” indicator does not illuminate.
3. When the announcement is finished, release the “SPEAK” Button.

4.2.2 Using all other BDM400 Series Microphones

1. Press the “ALL” button.

The “Zone Selected” indicators will illuminate on all zones.



NOTE: If a zone was already busy with another announcement the indicator will still illuminate, however depending on Priority Settings the announcement may not be broadcast to the relevant zone(s).

2. Wait for the “SPEAK NOW” Indicator to illuminate.
Speak slowly and clearly, ensuring the “MAX” indicator does not illuminate.
3. When the announcement is finished, release the “ALL” Button.

4.3 TO MAKE AN ANNOUNCEMENT TO SELECTED ZONES

1. Press the Zone Select Buttons for the required zones.
The “Zone Status” Indicators will flash to indicate the zone(s) have been selected.



NOTE: If a zone is already busy with another announcement the indicator will flash intermittently.

Depending on Priority Settings the announcement may not be broadcast to the relevant zone(s).

2. Press the “SPEAK” button.
The “Zone Status” Indicators will light continuously to show the announcement will be made to the selected zones, however see the above note regarding priority and “BUSY” zones.
3. Wait for the “SPEAK NOW” Indicator to illuminate.
Speak slowly and clearly, ensuring the “MAX” indicator does not illuminate.
4. When the announcement is finished, release the “SPEAK” Button.

4.4 FAULT REPORTING

If a fault is reported on the system the common “FAULT” Indicator will flash and the internal buzzer will sound.

To Accept the Fault and silence the buzzer, press the “FAULT ACCEPT” button.

Remedial action should be taken as soon as possible to correct faults as they impair the correct operation of the system.

4.5 TO BROADCAST DVA MESSAGES (ONLY AVAILABLE WHEN FITTED)

The BDM 400 Microphones can have additional switches fitted that enable them to broadcast DVA messages.

These switches are generally “flip-top” switches to prevent accidental operation and are normally a factory fit option.



NOTE: The actual operation of each microphone may differ depending on the switch type (either latching or non-latching), the message settings within the microphone (either All Call, Zonal, or Mixed) and the DVA settings within the BVRD2M.

4.5.1 To Broadcast to All Zones

Press the button for the required message.

The “Zone Status” Indicators will light continuously to show the DVA message is being broadcast to all zones.

4.5.2 To Broadcast to Selected Zones

1. Press the Zone Select Buttons for the required zones.
The “Zone Status” Indicators will flash to indicate the zone(s) have been selected.
2. Press the button for the required message.
The selected “Zone Status” Indicators will light continuously to show the DVA message is being broadcast to the selected zones.