

# Care2

## Installation Instructions



Manual name: Care2

Issue: 10

ECR: 3630

Date of issue: May 2019

© May 2019 Baldwin Boxall Communications Limited

Wealden Industrial Estate  
Farningham Road, Jarvis Brook  
Crowborough  
East Sussex  
TN6 2JR  
UK

Telephone: +44 (0)1892 664422

Facsimile: +44 (0)1892 663146

Email: [mail@baldwinboxall.co.uk](mailto:mail@baldwinboxall.co.uk)

Website: <http://www.baldwinboxall.co.uk>



This equipment has been designed and manufactured to conform to the following EC Standards:

EMC: EN55103-1 Environment Classification: E1,

EMC: EN55103-2 Environment Classification: E5,

Safety: EN60065

Failure to use the equipment in the manner described in the product literature will invalidate the conformity.

A "Declaration of Conformity" statement to the above standards and a list of auxiliary equipment used for compliance verification is available on request.

Amendment Record _____	vii
Proprietary Notice _____	vii
Precautions and Safety Information _____	viii
Environmental Conditions - - - - -	viii
General Safety Precautions - - - - -	viii

---



---

## Care2 Introduction

Description _____	1
Technical Specifications _____	2
Master & Slave Consoles - - - - -	2
Network Expansion Panel - - - - -	3
Disabled Refuge Remote - - - - -	4
Fire & Emergency Telephones- - - - -	5
Disabled Toilet Alarm (DTA Kit) - - - - -	6
Telephone Handset Enclosure- - - - -	7
Roaming Telephone Sockets - - - - -	7
Simplified Schematic Diagrams _____	8

---



---

## Installation

Consoles _____	11
Mounting Details- - - - -	11
C2CEK4 Line Card Connection Details - - - - -	12
Adding C2CEK4 Line Cards _____	13
Installing C2CFPE Interface Card _____	16
Installing C2CN Network Card _____	19
Setting Network Address- - - - -	21
Network Cable Connections - - - - -	22
Fire Panel Connections on C2CN - - - - -	23
External Call Output _____	24
External Call Settings using BVOCCA - - - - -	24
DRS Refuge Remote _____	25
Mounting Details- - - - -	25
Connection Details - - - - -	25
Fire / Stewards Telephones _____	26
Mounting Details - - - - -	26
Connection Details - - - - -	26

DTAKIT (Disabled Toilet Alarm) _____	27
Mounting Details- - - - -	27
Connection Details - - - - -	28
Jack Sockets _____	29
Mounting Details- - - - -	29
Connection Details - - - - -	29

---

---

## Controls & Indicators

LCD Display & Multi-Function Encoder _____	31
Front Panel LED Indicators _____	32
Internal Reset Buttons _____	32
Battery Connect (If Mains Power Unavailable) _____	32
DRS Remote Controls & Indicators _____	33
Fire / Emergency Telephone _____	34
Roaming Handset Enclosure _____	34

---

---

## Commissioning

Basic Hardware Commissioning Procedure _____	35
Master / Slave / NEP Indicator _____	37
"Master" (or Non-networked) Console - - - - -	37
"Slave" Console - - - - -	37
"NEP" Console - - - - -	37
Software Commissioning Procedures _____	38
Initial Commissioning using SD CARD - - - - -	38
Commissioning Using Ethernet (IP) Method - - - - -	40
Internal Device Detection Procedure _____	43
Auto Assign Outstations _____	45
Manually Specify Outstation Type _____	49
Manually Rename Remote Units _____	51
ASCII Character Set - - - - -	52
Roaming Telephone Enclosure Specific Parameters _____	53
System Menu Structure _____	55
System Parameters- - - - -	55
Line Parameters - - - - -	56
RTC (Real Time Clock) Adjustment - - - - -	56

Real Time Clock PEC (Processor Error Correction) - - - - -	56
RTC Power Requirements - - - - -	56

---



---

## SD and IP Configuration

Configuration Overview _____	57
SD Card Configurator _____	58
SD Card “ConsoleConfig” Page - - - - -	58
SD Card “LineSetups” Page - - - - -	59
To Enter Handset / Outstation Data - - - - -	59
Setting the SD Card Data Path - - - - -	61
Loading Configuration from an SD Card - - - - -	61
Saving Configuration to an SD Card - - - - -	61
SD Card “Logs” Page- - - - -	62
“OutstationSummary” Page- - - - -	62
IP Configurator _____	63
Setting Alternate IP Configuration on PC- - - - -	63
Setting Alternate TCP/IP Configuration - Windows XP - - - - -	63
Setting Alternate TCP/IP Configuration - Windows 7 - - - - -	66
IP Configuration “ConsoleConfig” Page - - - - -	69
IP Configuration LineSetups Page - - - - -	70
IP Configuration Logs Page - - - - -	70
IP Configuration OutstationSummary Page - - - - -	70

---



---

## Operation

Accept a Single Incoming Call _____	71
Multiple Incoming Calls _____	72
Selecting a Single Call- - - - -	72
Selecting All Incoming Calls - - - - -	73
Place Current Call on “Hold” _____	74
End a Call _____	74
Answer a Disabled Toilet Alarm _____	75
Make a Call _____	76
Call a Single Outstation- - - - -	76
Call All Outstations - - - - -	76
Make a Call when the current Call is on “Hold” _____	77

---



---

## Faults and Maintenance

Accept a Fault & Silence the Sounder _____	79
Re-announcing Faults _____	79
Automatic Fault Clearance _____	79
Faults Announced while “In Call” _____	80
View Fault History Log _____	80
Maintenance Menu Structure _____	81
Fault Codes & Basic Faultfinding _____	81
“Battery Charger” - Local Console Fault - - - - -	81
“Power Supply” - Local Console Fault - - - - -	81
“System Restart xx” - Local Console Fault - - - - -	81
“Local Loop” - Local Console Fault - - - - -	82
“Lo Z” - Line Fault - Local Console Fault - - - - -	82
“Hi Z” - Line Fault - Local Console Fault - - - - -	82
“NW Audio Loop” - Network Audio Fault - - - - -	82
“NW Loop” - Network Data Fault - - - - -	82
Deep Discharge (Low Voltage) Protection - - - - -	82
Routine Maintenance Requirements _____	83
Appointment of a “Responsible Person” - - - - -	83
Routine Testing - - - - -	83
Daily Check - Fault Indicators - - - - -	83
Weekly Functional Test - - - - -	84
Six Monthly Inspection by a “Competent Person” - - - - -	84

## AMENDMENT RECORD

Change Note Number	Nature of Amendment	Date of Amendment
2853	Issue 7: Update Network Commissioning Procedure	July 2014
3223	Issue 8: Change to user PIN & minor updates	June 2017
3461	Issue 9: Update firmware V4.02	Dec 2018
3630	Issue 10: Removed firmware reference	May 2019

## PROPRIETARY NOTICE

All data and information contained within this manual is of a proprietary nature with the exclusive title to the same held by Baldwin Boxall Communications Limited. The possession of this manual and the use of the information is, therefore, restricted only to those persons duly authorised by Baldwin Boxall Communications Limited.

Do not reproduce, transcribe, store in a retrieval system or translate into any language, any part of this manual without the prior permission of Baldwin Boxall Communications Limited.

In the interest of continual product development, Baldwin Boxall Communications Limited reserves the right to make changes to product specification without notice or liability. Use of Baldwin Boxall Communications Limited products as critical components in life support systems is not authorised except with express written approval from Baldwin Boxall Communications Limited.

# PRECAUTIONS AND SAFETY INFORMATION

## Environmental Conditions

Unless otherwise stated the following Technical Specifications apply to this equipment:

AC Supply Voltage	230V ± 10% RMS 50Hz AC
DC Supply Voltage	21V to 27.6V (Nominal 24V) DC
Temperature (Operating & Storage)	-5°C up to +40°C
Humidity Range / IP Rating	0% - 90% Non Condensing / IP30

This equipment must not be installed in an area that is subject to a corrosive atmosphere, excessive moisture or may allow water or other liquids to come into contact with the unit or its external connections.

In the close proximity of some radio frequency transmitting devices, the signal to noise ratio of this product may be reduced. If this occurs, re-location of the equipment or the signal cables is recommended.



### CAUTION

This product must only be disposed of in accordance with the WEEE directive.

## General Safety Precautions

Personnel who install, maintain or repair this equipment must read the safety information below before starting work.



### WARNING

This equipment is intended for continuous operation and as such should be permanently connected to the mains supply. This unit does not contain an external mains switch. An all-pole Switch / Circuit Breaker with a separation of 3 mm in each pole shall be incorporated in the electrical supply spur feeding the unit, and this must be suitably marked to prevent inadvertent or accidental useage.

**WARNING**

Always ensure that this equipment is correctly earthed by connection to an AC mains supply with a protective earth connection.

**WARNING**

Voltages in excess of 30V RMS AC or 50V DC are considered Hazardous and in certain circumstances can be lethal.

This product contains wiring and terminations that are energised to 230V RMS AC mains.

**WARNING**

If Functional Testing, Maintenance, or Repair is to be completed with the Mains Power (and/or battery backup) connected then this should only be undertaken by personnel who are fully aware of the danger involved and who have taken adequate precautions and training.

Terminals marked with the "High Voltage" symbol are considered hazardous and the external wiring connected to these terminals requires installation by suitably trained personnel.

**WARNING**

Note that this equipment uses battery backup, and if the Mains Supply is disconnected Hazardous voltages will still be accessible on the terminals marked with the "High Voltage" symbol.

**WARNING**

Always replace blown fuses with the correct type and rating. If a fuse continues to blow further investigation is required.

**WARNING**

The 24V DC batteries used within this system can deliver extremely high currents that can cause burns or fire. Care should be taken to ensure tools or jewelry etc are prevented from causing a Short Circuit.

**CAUTION: ELECTRO-STATIC SENSITIVE DEVICES**

This product contains Electro-static Sensitive Devices. Observe the relevant precautions for the protection of ESDs when handling this equipment.



# I Care2 Introduction

## I.1 DESCRIPTION

The Care2 Emergency Voice Communication System is a fully monitored Communication System that allows Disabled Refuge Remotes, Fire & Emergency Telephones, Disabled Toilet Alarms, and Fire Telephone Sockets & Storage Enclosures to be connected to just one system. It has been developed in accordance with BS5839-9:2011.

The system has three main components - the Master Console, Network Expansion Panels, and the Outstations. The Outstations and Fire & Emergency Telephones are supplied in different styles to suit any installation.

The Care2 system is radial (or “Star Wired”) to each Outstation with Power & Audio transmitted on a single pair of conductors.

Each Care2 Console can address four Outstations by default, and this can be increased to a maximum of 16 Outstations by fitting additional Expansion Kits.

Configuration information is stored on internal SD Cards.

The Care2 System is battery backed with integral batteries & charger and is fully monitored to meet the requirements of BS5839-9:2011.

## 1.2 TECHNICAL SPECIFICATIONS

### 1.2.1 Master & Slave Consoles

<b>C2CB4 (Black) &amp; C2CS4 (Stainless Steel) Consoles</b>	
System self-monitoring	BS5839-9:2011 compliant
Power Supply	200V / 230V AC with integral batteries & charger
Power Consumption	75VA (plus approx 50mA per Outstation)
Front Panel Indicators	LCD Matrix Display & Rotary Encoder for System Control LEDs: Power, Incoming Call, Refuge Areas Active, System Healthy, Processor Restart, Common Fault, Processor Fault
Remote Signalling of Fault	Volt-free contact, closing/opening set at installation
Dimensions (W X H x D)	430mm x 310mm (7U) x 130mm
Bezel Dimensions (W x H)	470mm x 350mm
Weight	14Kg (with batteries)
Bezel Cutout (W x H x D)	440mm x 320mm x 135mm
Knockouts	20mm diameter x 23 in top only
Security	Handset behind lockable door
Temp / Humidity Range	-10 to +30°C (storage and operating) / 95% Non Condensing
Internal Memory Card	SD (SDSC) 1GB Max

Figure 1.1 — Typical Care2 Console



The Care2 Console can be rack mounted using the C2CRM Rack Mounting kit and is 7U high, although 2U must be left above to allow for terminations.

## 1.2.2 Network Expansion Panel

<b>C2CBNEP (Black) &amp; C2CSNEP (Stainless Steel) Network Expansion Panels</b>	
System self-monitoring	BS5839-9:2011 compliant
Power Supply	200V / 230V AC with integral batteries & charger
Power Consumption	75VA (plus approx 50mA per Remote Unit)
Front Panel Indicators	LCD Matrix Display & Rotary Encoder for System Control LEDs: Power, Incoming Call, Refuge Areas Active, System Healthy, Processor Restart, Common Fault, Processor Fault
Remote Signalling of Fault	Volt-free contact, closing/opening set at installation
Dimensions (W X H x D)	430mm x 310mm (7U) x 130mm
Bezel Dimensions (W x H)	470mm x 350mm
Weight	14Kg (with batteries)
Bezel Cutout (W x H x D)	440mm x 320mm x 135mm
Knockouts	20mm diameter x 23 in top only
Temp / Humidity Range	-10 to +30°C (storage and operating) / 95% Non Condensing
Internal Memory Card	SD (SDSC) 1GB Max

Figure 1.2 — Typical Care2 Network Expansion Panel



Each Network Expansion Panel can connect to 16 Outstations, and upto 15 Network Expansion Panels (and one Master Console) can be networked together to allow upto 256 Remote Units.



**NOTE:** Calls cannot be managed at Network Expansion Panels.

## 1.2.3 Disabled Refuge Remote

<b>C2RRG (Green) &amp; C2RRS (Stainless Steel) Refuge Remotes</b>	
Front Panel Indicators	Status, System OK
Front Panel Control	Call / Accept Button
Internal Control	Volume Control
Power Supply	16 - 20V DC
Current Consumption	1.5mA@16V (0.03W) Standby, 40mA@10V (0.4W) Active
Dimensions (W X H x D)	134mm x 134mm x 48mm (Front panel & backbox)
Bezel Dimensions (W x H)	154mm x 154mm (10mm radius)
Bezel Cutout (W x H x D)	136mm x 136mm (10mm radius)
Knockouts	20mm and 25mm diameter in sides of backbox
Weight	0.75 Kg
Temperature Range	-10 to +40°C (storage and operating)

Figure 1.3 — Typical Care2 Disabled Refuge Remotes



## 1.2.4 Fire & Emergency Telephones

<b>C2FTRP (Red), C2FTSP (Stainless Steel), C2ETGP (Green) Telephones</b>	
Front Panel Indicator	System OK
Power Supply	16 - 20V DC
Current Consumption	>1.5mA@16V (0.03W) Standby, 40mA@10V (0.4W) Active
Dimensions (W X H x D)	130mm x 330mm x 75mm (Front panel & backbox)
Bezel Dimensions (W x H)	170mm x 370mm
Bezel Cutout (W x H x D)	136mm x 336mm x 80mm
Knockouts	1 x 20mm diameter in top of backbox
Weight	2.2 Kg
Temperature Range	-10 to +40°C (storage and operating)

Figure 1.4 — Typical Care2 Fire & Emergency Telephones



## 1.2.5 Disabled Toilet Alarm (DTA Kit)

<b>DTAKIT (White) &amp; DTAKITS (Stainless Steel) Disabled Toilet Alarm</b>	
Indicators	Active (Over Door) Indicator, Status LED
Front Panel Control	Pull Cord to Activate, Reset Button
Power Supply	16 - 20V DC
Current Consumption	1.5mA@16V (0.03W) Standby, 40mA@10V (0.4W) Active
Dimensions	W X H x D
Over Door Light / Sounder	85mm x 85mm x 58mm (excluding back box)
Reset Point	85mm x 85mm x 13mm (excluding back box)
Ceiling Pull Cord	87mm diam x 30mm (including surface mount enclosure)
Back Box requirements	<i>Back boxes are not supplied with the DTA Kit</i>
Over Door Light / Sounder	25mm deep single gang flush box or "round cornered" plastic surface box is required
Reset Point	25mm deep single gang flush box or "round cornered" plastic surface box is required
Ceiling Pull Cord	Supplied with its own surface mount enclosure
Temperature Range	-10 to +40°C (storage and operating)

Figure 1.5 — Disabled Toilet Alarm Components (DTA Kit)



## 1.2.6 Telephone Handset Enclosure

<b>C2RTEB (Black) &amp; C2RTES (Stainless Steel) Enclosures</b>	
Power Consumption	>1.5mA@16V (0.03W) per monitored handset
Dimensions (W X H x D)	430mm x 310mm (7U) x 130mm
Bezel Dimensions (W x H)	470mm x 350mm
Bezel Cutout (W x H x D)	440mm x 320mm x 135mm
Knockouts	20mm diameter x 23 in top only
Security	Handsets stored behind lockable door
Weight	6.2Kg +0.35Kg per handset
Temperature Range	-10 to +30°C (storage and operating)
Humidity Range	95% Non Condensing

Figure 1.6 — Typical Care2 Handset Enclosure



## 1.2.7 Roaming Telephone Sockets

Figure 1.7 — Typical Roaming Telephone Socket Plates

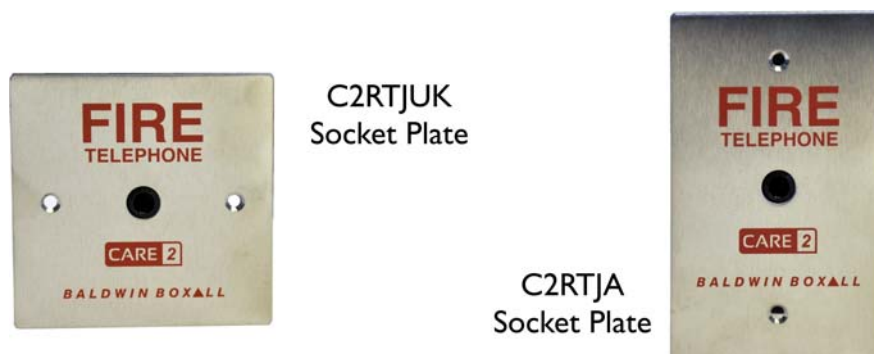

## 1.3 SIMPLIFIED SCHEMATIC DIAGRAMS

Figure 1.8 — Simplified Care2 Schematic Diagram

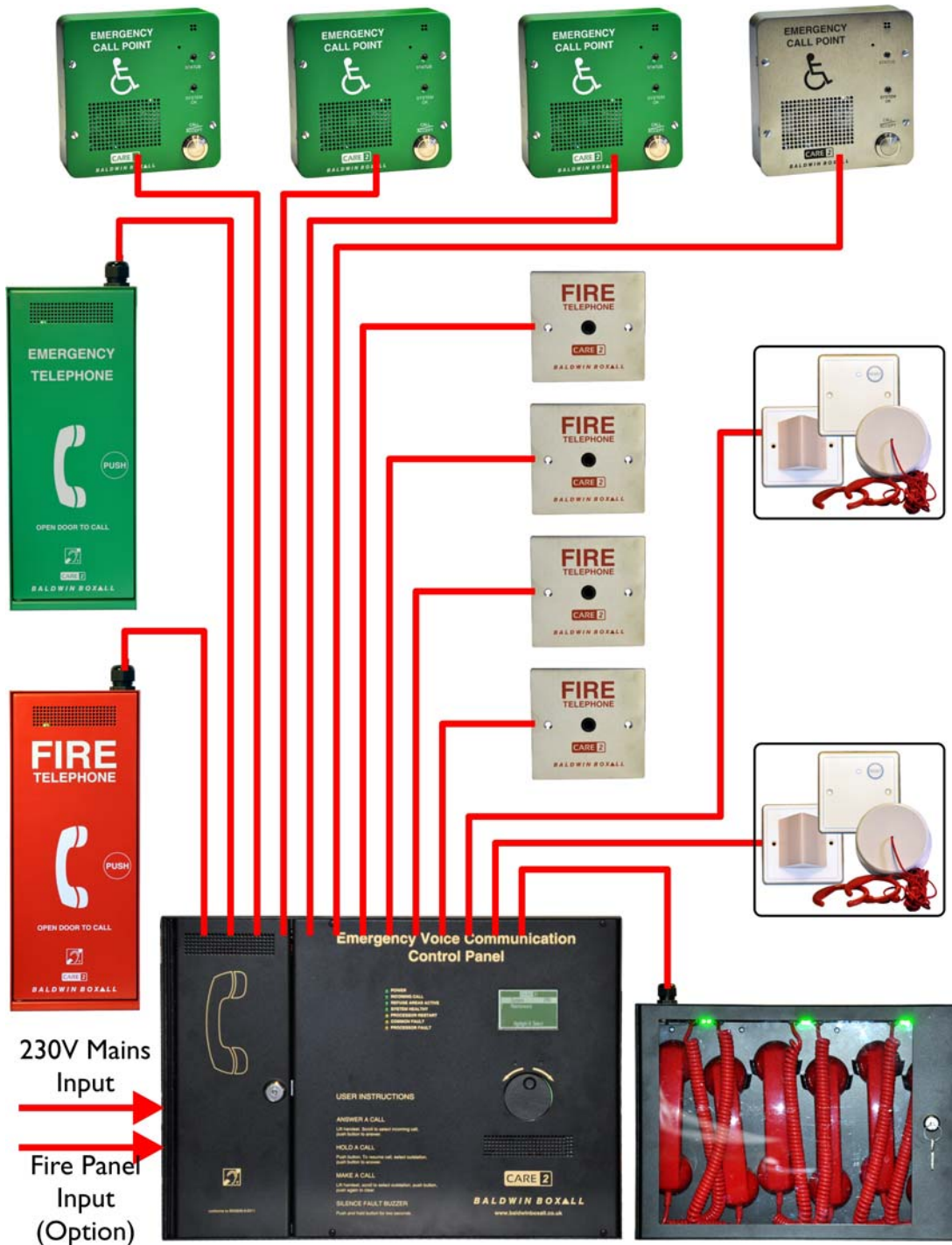

A mixture of Outstations can be fitted to the Care2 Console as shown in Figure 1.8. The system is “Star Wired” with each Outstation connected using its own pair of wires.



**NOTE:** Fire Rated screened cable should be used. If Fire Rated cable is not used then screened cable is recommended to ensure the best audio quality.

Figure 1.9 — Typical Network Schematic Diagram

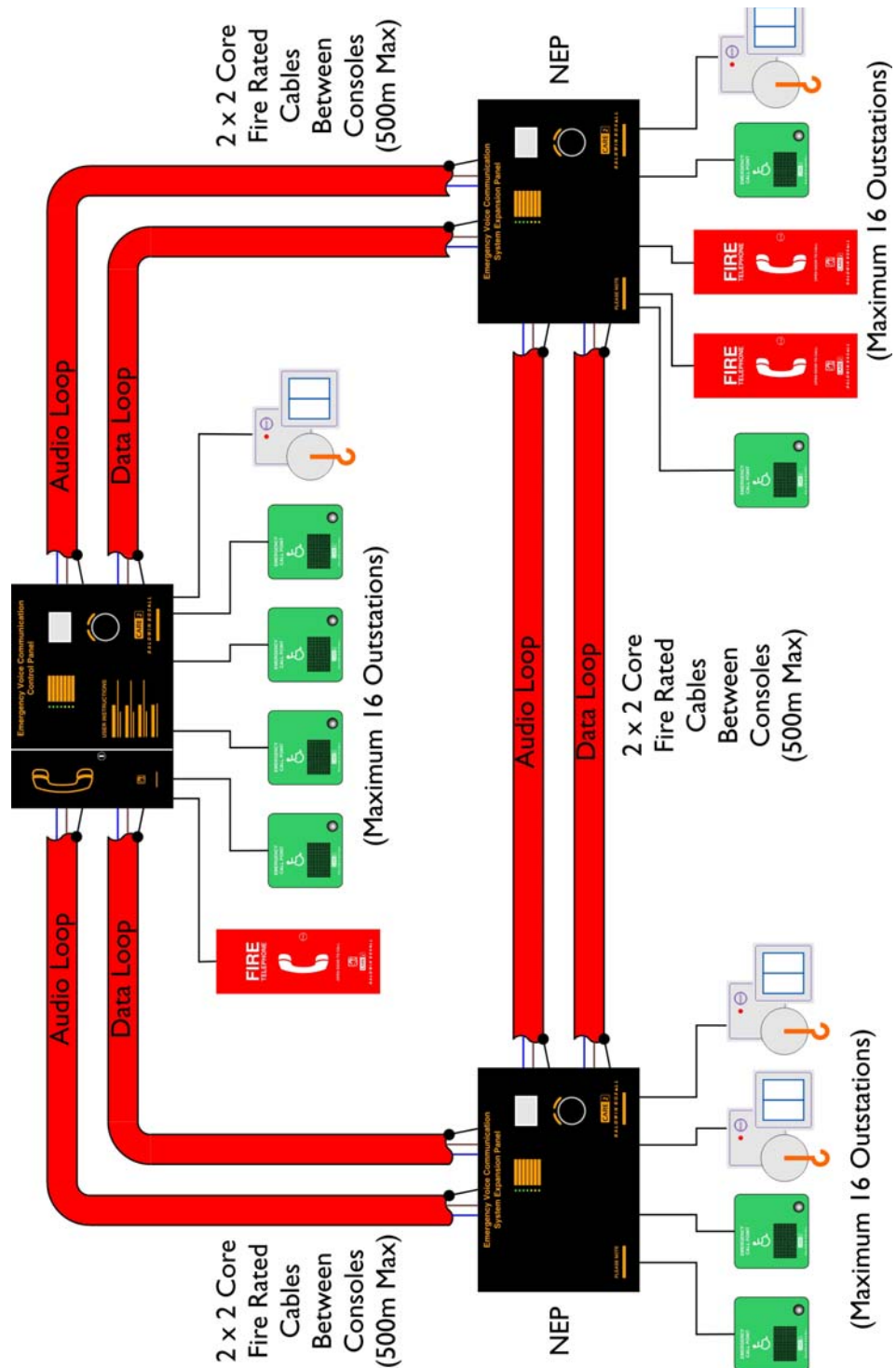

*NOTE: Each Console (and NEP) can have a maximum 16 Outstations attached.*

*Upto 15 NEPs can be networked together (or 14 using a Master & a Slave Consoles) to allow upto 256 Outstations.*



## 2 Installation

### 2.1 CONSOLES

#### 2.1.1 Mounting Details

The Consoles have four M8 mounting holes, the top two being a “keyhole” design that enables quick and simple mounting.

Ensure all four mounting points are used to mount the console securely to the wall / surface.

Figure 2.1 — Console Mounting Holes

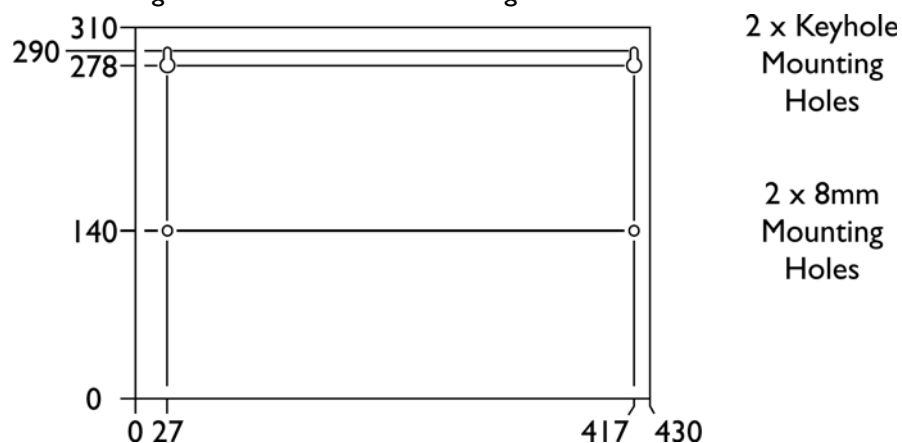

#### **WARNING**

Ensure the wall / surface is strong enough to support the weight of the console (14Kg including batteries).

## 2.1.2 C2CEK4 Line Card Connection Details

The Console can contain up to four C2CEK4 Line Cards, with each Line Card connecting up to Four Outstations.

The Care2 Outstations are “Star Wired” to the console, with each Outstation having its own pair of conductors.

Figure 2.2 — Line Card Site Wiring Connections

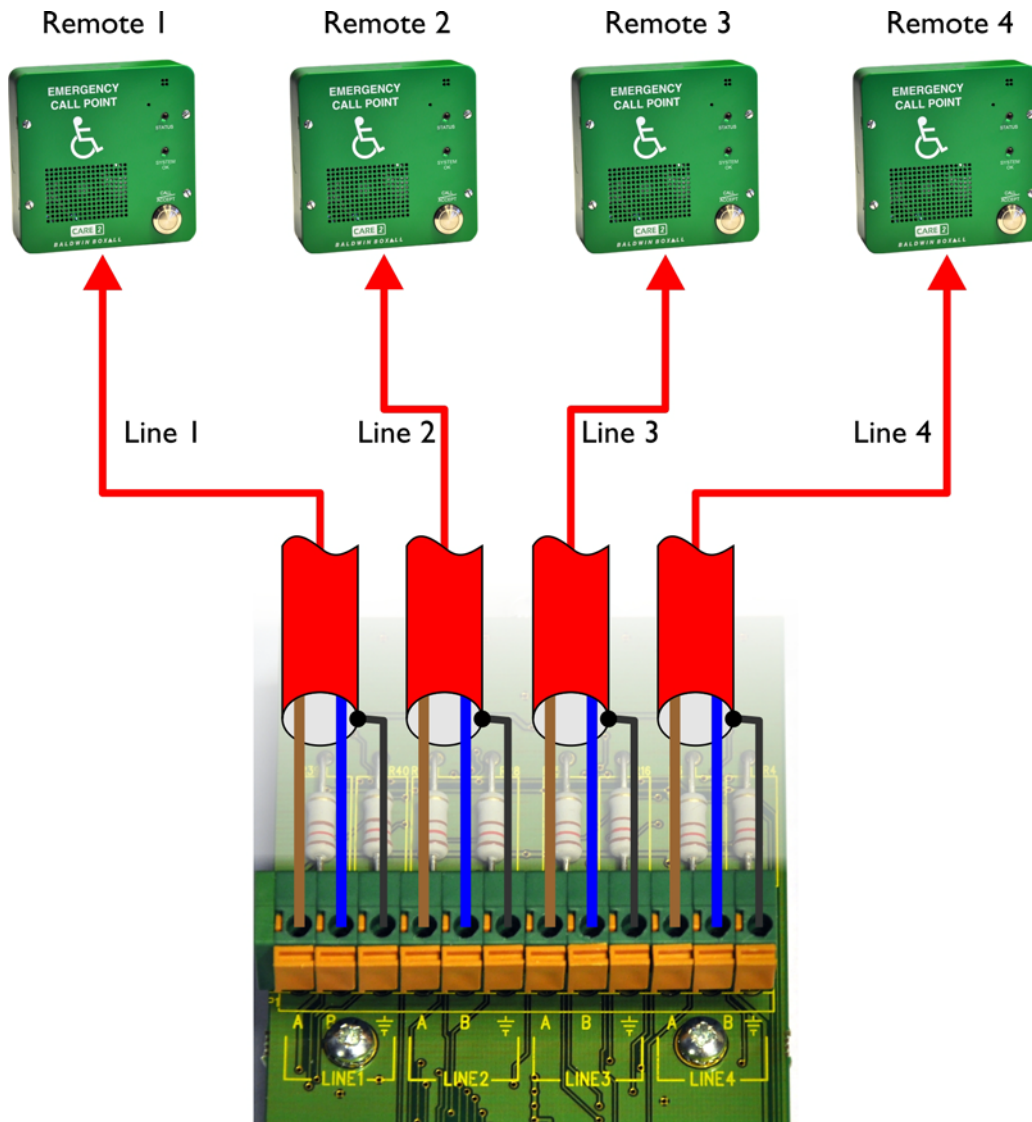

The termination blocks on the Line Card are “Cage Clamp” terminals to enable quick and secure connections.



*NOTE: Fire Rated screened cable should be used. If Fire Rated cable is not used then screened cable is recommended to ensure the best audio quality.*



*NOTE: The maximum total resistance for each Line is 400Ω regardless of the type of cable in use.*

## 2.2 ADDING C2CEK4 LINE CARDS

As supplied the Console contains one C2CEK4 Line Card, enabling Four Outstations to be connected. Three additional Line Cards can be added enabling upto 16 Outstations.

Figure 2.3 — Typical C2CEK4 Expansion Line Card

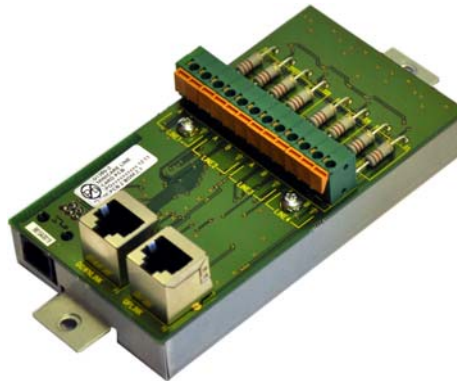

### WARNING

Before attempting to fit this component, ensure the Mains Power Supply and Battery Backup have been disconnected as described in the following procedure.

1. Ensure the Mains 230V supply is isolated.
2. Remove the 4 off M3x10 screws securing the front door of the Console.

Figure 2.4 — Remove 4 x Front Panel Screws



3. Carefully open the hinged door.
4. Disconnect and isolate the battery backup supply.
5. Carefully undo the M4x8 screw holding the cable loom (the screw will be held captive by the cable tie base).

Figure 2.5 — Internal View - Undo Loom Securing screw

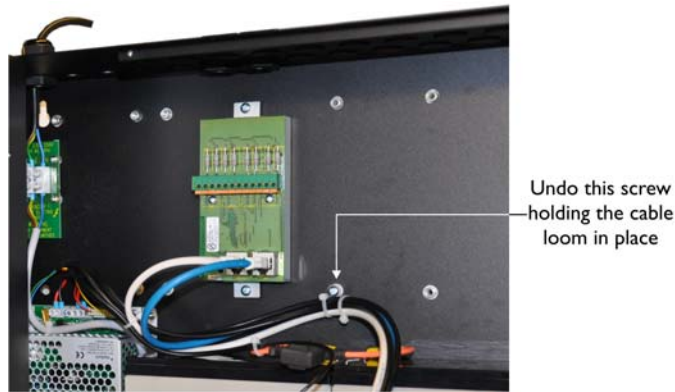

6. Fit the New C2CEK4 Line Card next to the first card using the M4x8 screws as shown in Figure 2.6.

Figure 2.6 — New C2CEK4 Line Card Fitted

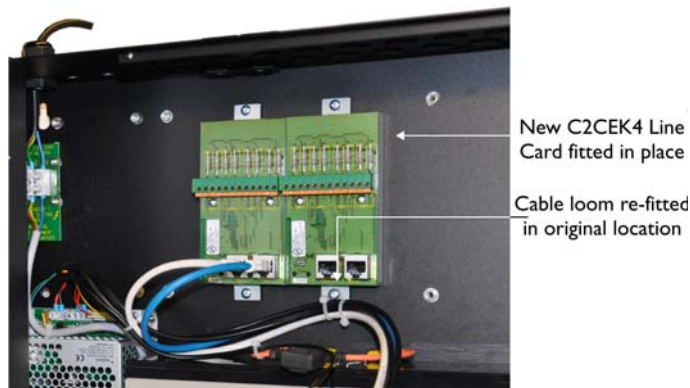

7. Disconnect the BLUE RJ45 “Uplink” cable from the first Line Card and connect the BLUE RJ45 cable to the “Uplink” connection on the new Line Card as shown in Figure 2.7.
8. Fit the Red Link Cable between the “Uplink” connector on the original Line Card and the “Downlink” connector on the new Line Card.

Figure 2.7 — New C2CEK4 Line Card Installed and Connected

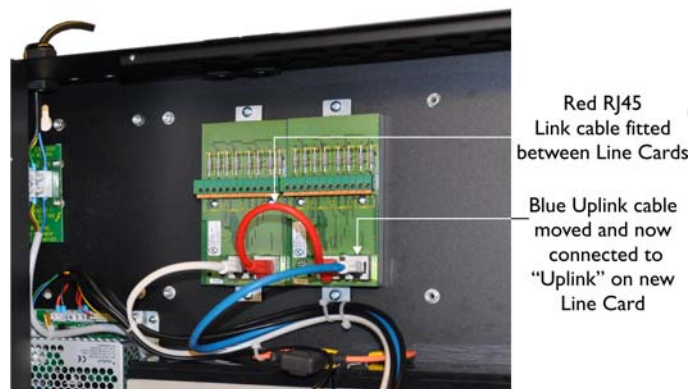

The New Line Card is now installed and ready for connection to the Site Cabling (shown in Figure 2.2).

9. To fit the 3rd & 4th Line Cards repeat steps (6) to (9) but without loosening the cable loom mount.

Figure 2.8 — Console with Three Line Cards Fitted

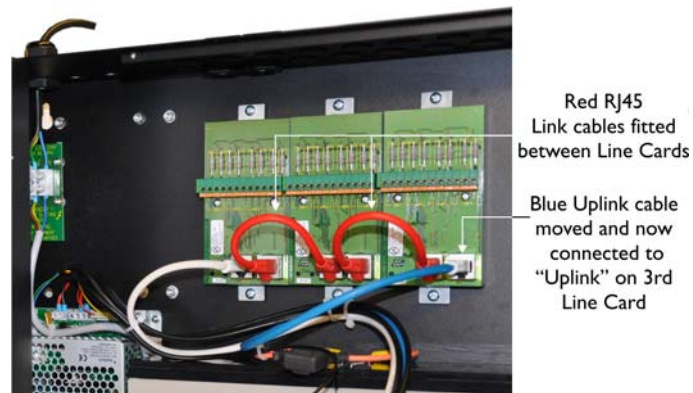

Figure 2.9 — Console with Four Line Cards Fitted



---

*NOTE: Before the new C2CEK4 Line cards can be used the Device Detection procedure must be followed.  
See section 4.4 on page 43 for details.*

---

## 2.3 INSTALLING C2CFPE INTERFACE CARD

As supplied the Care2 system is permanently active and all DRS Refuge Remotes are able to make calls all the time.

The C2CFPE Fire Panel Interface card enables the DRS Refuge Remotes to be active only when a Fire Panel is active.

The Interface Card also provides the Common Fault Volt Free contacts and the Ethernet contacts.

Figure 2.10 — Typical C2CFPE Expansion Line Card

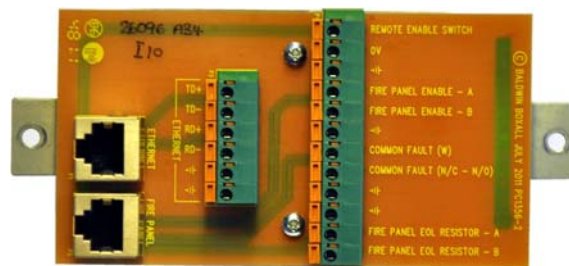

### WARNING

Before attempting to fit this component, ensure the Mains Power Supply and Battery Backup have been disconnected as described in the following procedure.

1. Ensure the Mains 230V supply is isolated.
2. Remove the 4 off M3x10 screws securing the front door of the Console.

Figure 2.11 — Remove 4 x Front Panel Screws



3. Carefully open the hinged door.
4. Disconnect and isolate the battery backup supply.
5. Fit the C2CFPE unit to the left of the first line card using the M4x8 screws provided.

Figure 2.12 — Internal View - C2CFPE unit mounted in position



6. Connect the YELLOW RJ45 cable to the FIRE PANEL connector as shown in Figure 2.13.

Figure 2.13 — Yellow RJ45 Cable connected to C2CFPE



7. The YELLOW RJ45 cable should be connected to the FIRE PANEL connection on the Front Panel board.

Figure 2.14 — C2CFPE Connection to Front Panel

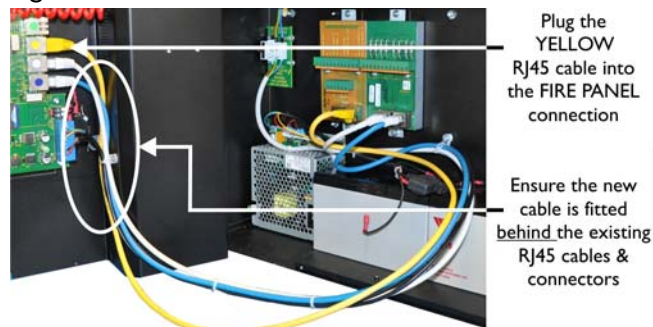

8. Secure the green and yellow cables to the existing loom using the cable ties provided.

Figure 2.15 — Recommended cable tie positions

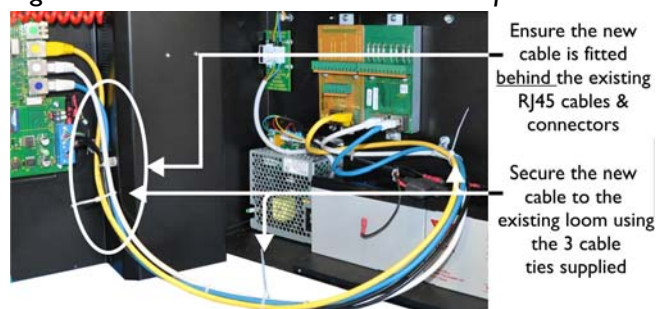

Figure 2.16 — Connection Details for Fire Panel with Dedicated CCT

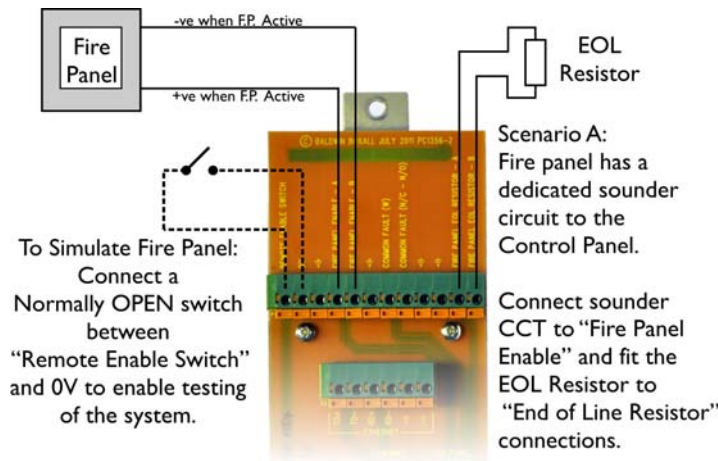
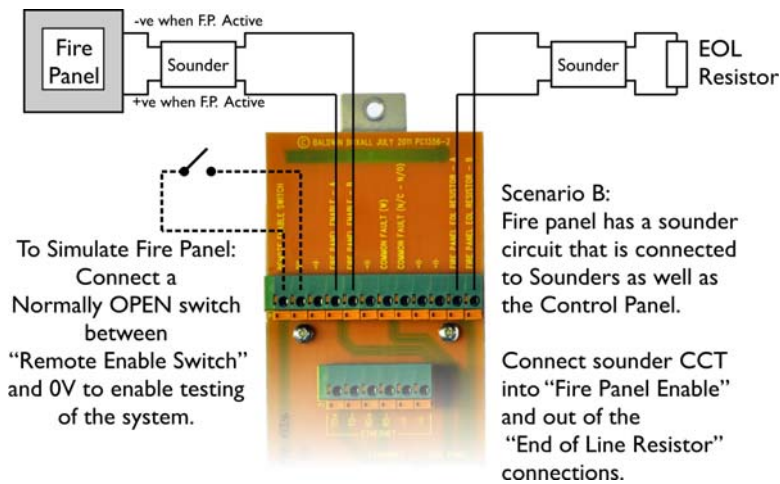

Figure 2.17 — Connection Details for Fire Panel with Sounders in CCT



To enable the Fire Panel input set the "DRS Enable" option in the System Menu to "N - Closed" (see Section 4.9.1 on page 55).



*NOTE: In a Networked System with a Master and a Slave console BOTH must have a C2CFPE module fitted.*

*The Fire Panel connections (and Remote Enable Switch if required) must be connected to both the Master and Slave consoles.*

## 2.4 INSTALLING C2CN NETWORK CARD

The C2CN Network Card enables Consoles & Network Expansion Panels (C2CBNEPs) to be connected together.

The C2CN also includes the C2CFPE Fire Panel terminations and connections (see Figure 2.26 and Figure 2.27).

Figure 2.18 — Typical C2CN Network Card

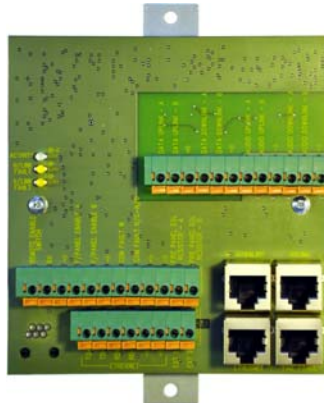

### WARNING

Before attempting to fit this component, ensure the Mains Power Supply and Battery Backup have been disconnected as described in the following procedure.

1. Ensure the Mains 230V supply is isolated.
2. Remove the 4 off M3x10 screws securing the front door of the Console.

Figure 2.19 — Remove 4 x Front Panel Screws



3. Carefully open the hinged door.
4. Disconnect and isolate the battery backup supply.

5. Fit the C2CN unit to the left of the first line card using the M4x8 screws provided.

Figure 2.20 — Internal View - C2CN mounted in position

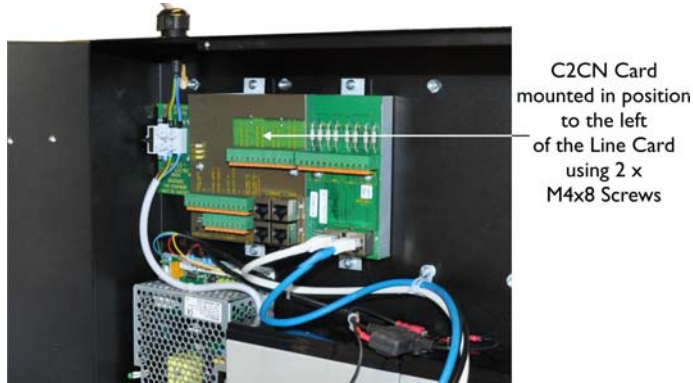

6. Connect the YELLOW RJ45 cable to the FIRE PANEL connector as shown in Figure 2.21.

Figure 2.21 — C2CN Fire Panel Connection details

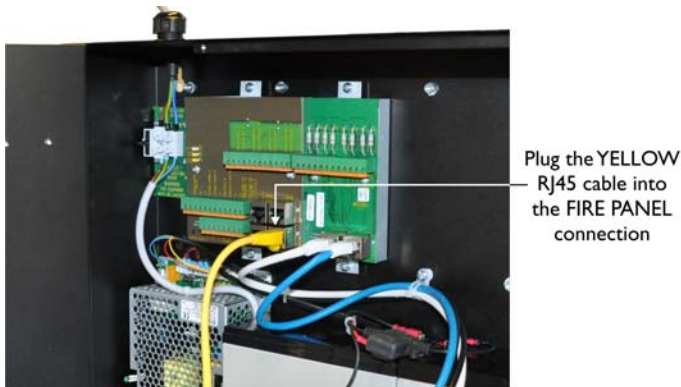

7. Move the WHITE RJ45 cable from the Line Card to the DOWNLINK connector on the network card.

Figure 2.22 — Network Downlink Connection

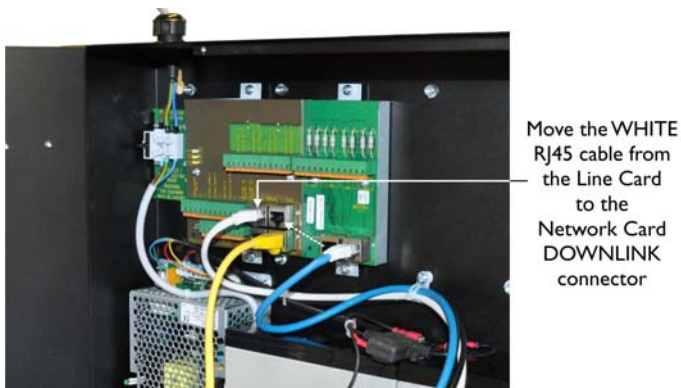

8. Fit the short RED RJ45 between the Network Card UPLINK connector and the Line Card DOWNLINK connector.

Figure 2.23 — Red RJ45 Link Between Network and Line Card



9. The YELLOW RJ45 cable should be connected to the Fire Panel connector on the Front Panel board as shown in Figure 2.24.

Ensure the new cable is fitted behind the existing cables and secured to the existing loom using the cable ties provided.

Figure 2.24 — C2CN Connections to Front Panel

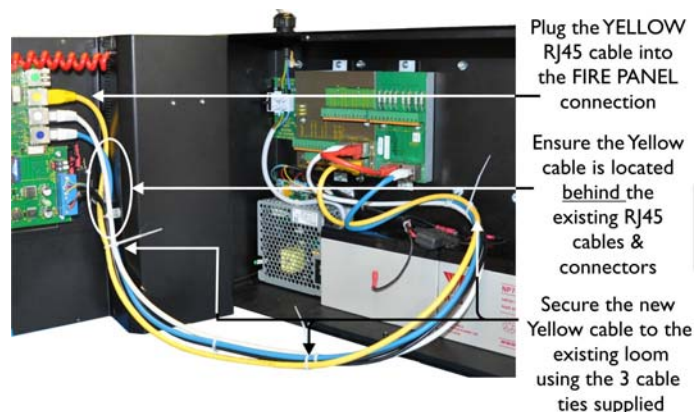

## 2.4.1 Setting Network Address



*NOTE: The Network Address is normally set during Commissioning. To manually set the Network Address use this procedure.*

1. Clear Device Assignments (refer to Section 7.6 on page 81).
2. Set the Network Address (refer to Section 4.9 on page 55).
3. Perform the Internal Device Detection Procedure (refer to Section 4.4 on page 43) and ensure it is successful.



*NOTE: Network Communication between Panels may fail and Faults may not be reported correctly if the Network Address is not set.*

## 2.4.2 Network Cable Connections

Figure 2.25 — Typical Network Cable Connections

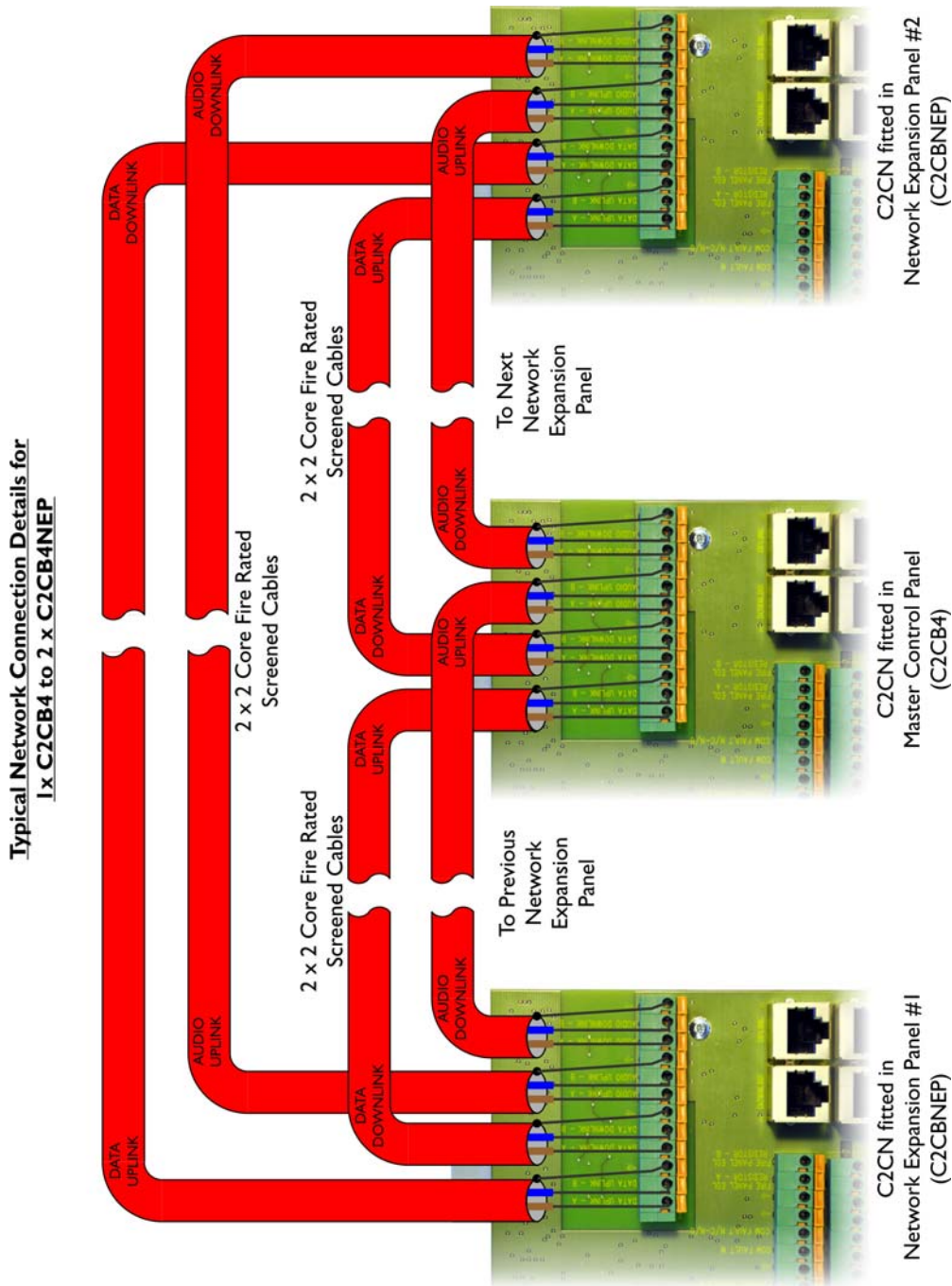

The network is configured as a loop with 2 x 2 Core Fire Rated Cables (a Data pair and an Audio pair) between the Master Console and each Network Expansion Panel.

The maximum cable distance between each Console is 500m.



**NOTE:** Ensure the Network Address has been Manually Set on all Network Panels - refer to Section 2.4.1 for details.

## 2.4.3 Fire Panel Connections on C2CN

Figure 2.26 — Connection Details for Fire Panel with Dedicated CCT

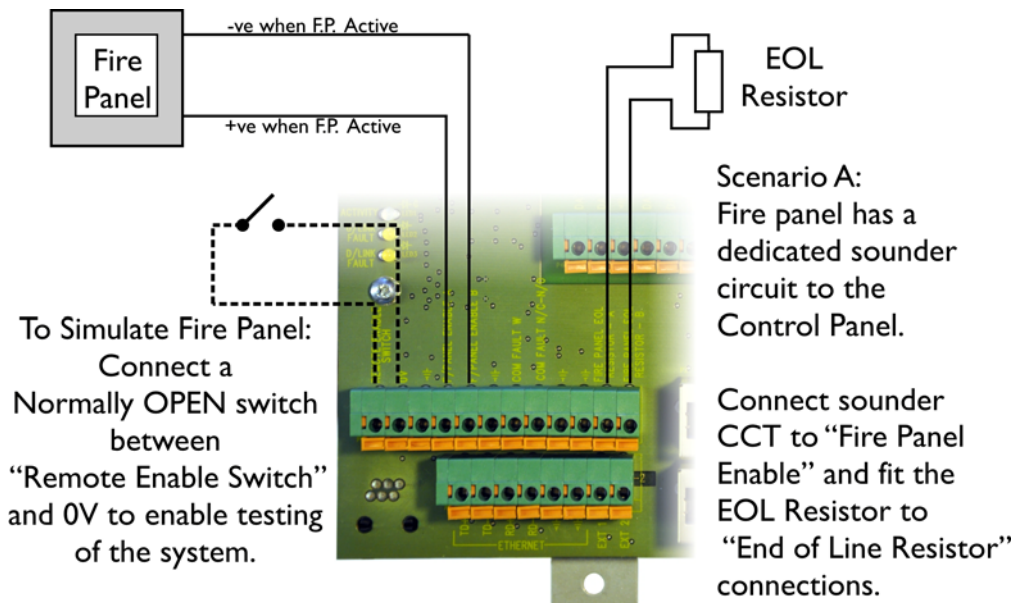
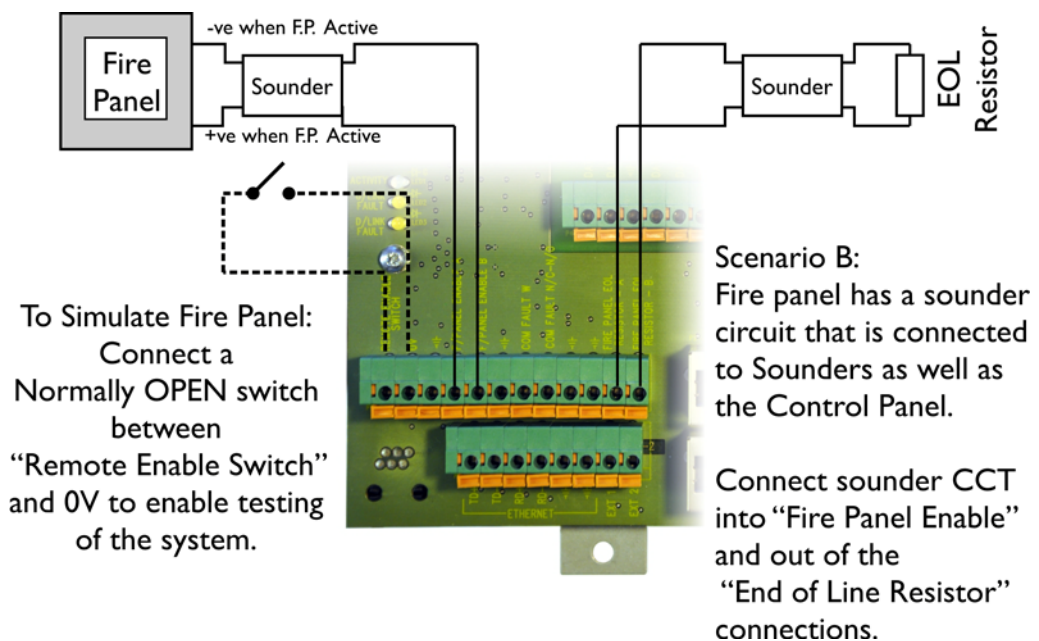

Figure 2.27 — Connection Details for Fire Panel with Sounders in CCT



To enable the Fire Panel input set the “DRS Enable” option in the System Menu to “N - Closed” (see Section 4.9.1 on page 55).



*NOTE: In a Networked System with a Master and a Slave console both will have a C2CN module fitted.*

*The Fire Panel connections (and Remote Enable Switch if required) must be connected to both the Master and Slave consoles.*

## 2.5 EXTERNAL CALL OUTPUT

The External Call Output is an Option that causes a pair of contacts to operate after a delay if a call comes in but the door is not opened.

The delay can be set from immediate to approximately 3 minutes.

Figure 2.28 — Delayed Call Output settings

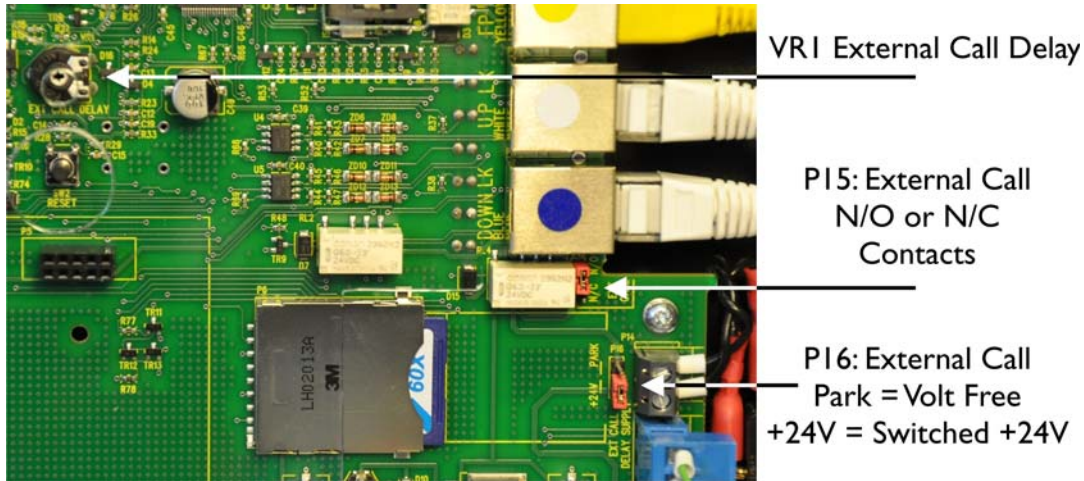

*NOTE: The Console must be fitted with either a C2CN or C2CFPE to access the External Call terminations.*

*The External Call output is available on the following Consoles:  
C2CB4 - BN 27693 and later, C2CS4 - BN 27133-DCO and later.*

### 2.5.1 External Call Settings using BVOCCA

If a BVOCCA Call Alert Module is used, P15 must be set to N/O and P16 set to +24V.

The connections to the C2CN and C2CFPE are shown below:

Figure 2.29 — BVOCCA Connection details

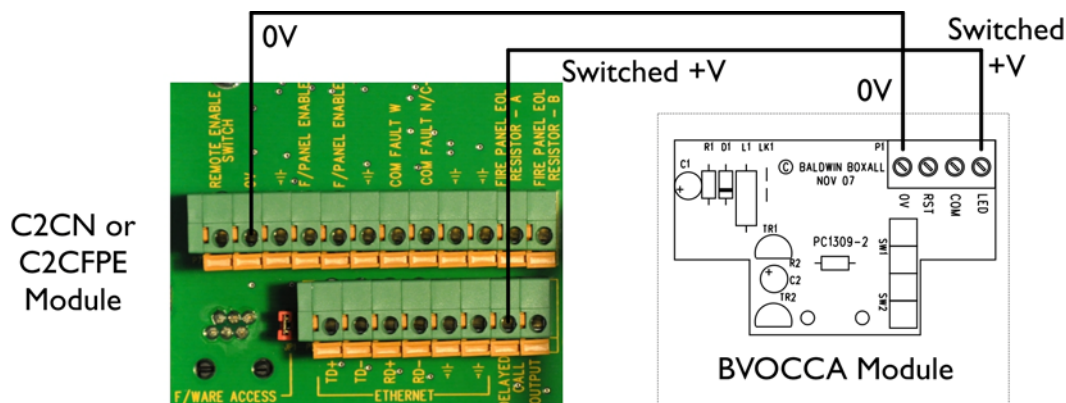



## 2.7 FIRE / STEWARDS TELEPHONES

### 2.7.1 Mounting Details

Figure 2.32 — Mounting Holes for Fire / Stewards Telephone

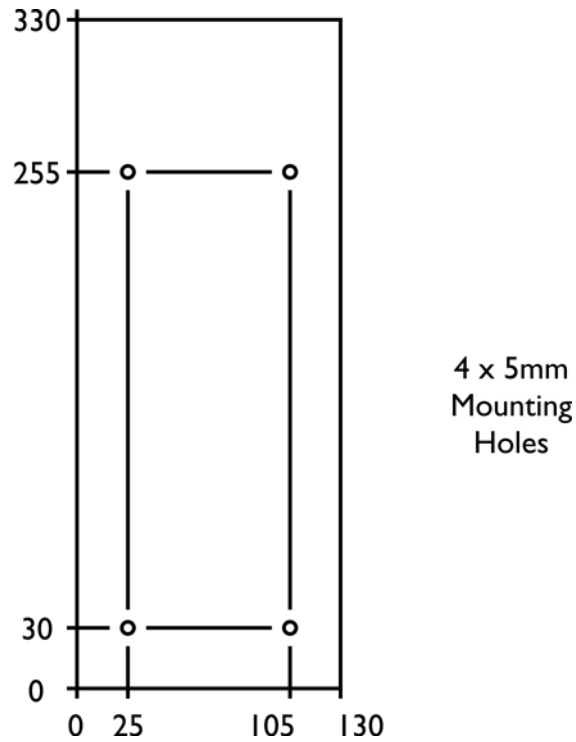

### 2.7.2 Connection Details

Figure 2.33 — Site Wiring Connections for Fire / Stewards Telephone

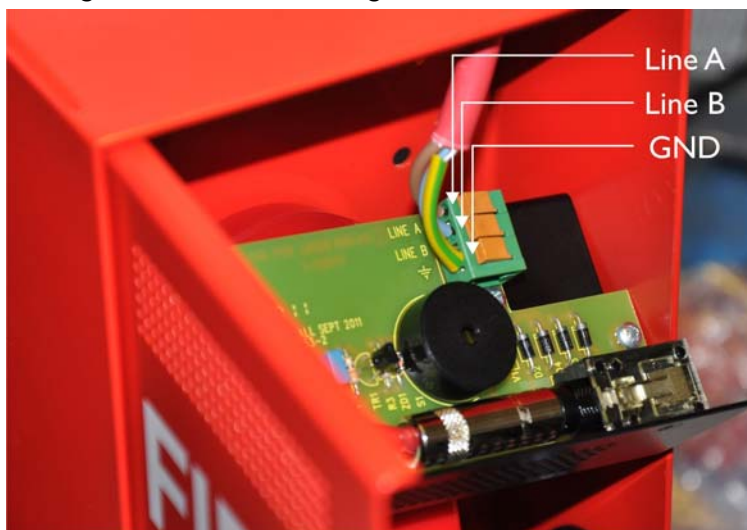

The termination blocks on the DRS unit are “Cage Clamp” terminals to enable quick and secure connections.

## 2.8 DTAKIT (DISABLED TOILET ALARM)

### 2.8.1 Mounting Details

Figure 2.34 — DTAKIT Installation Instructions

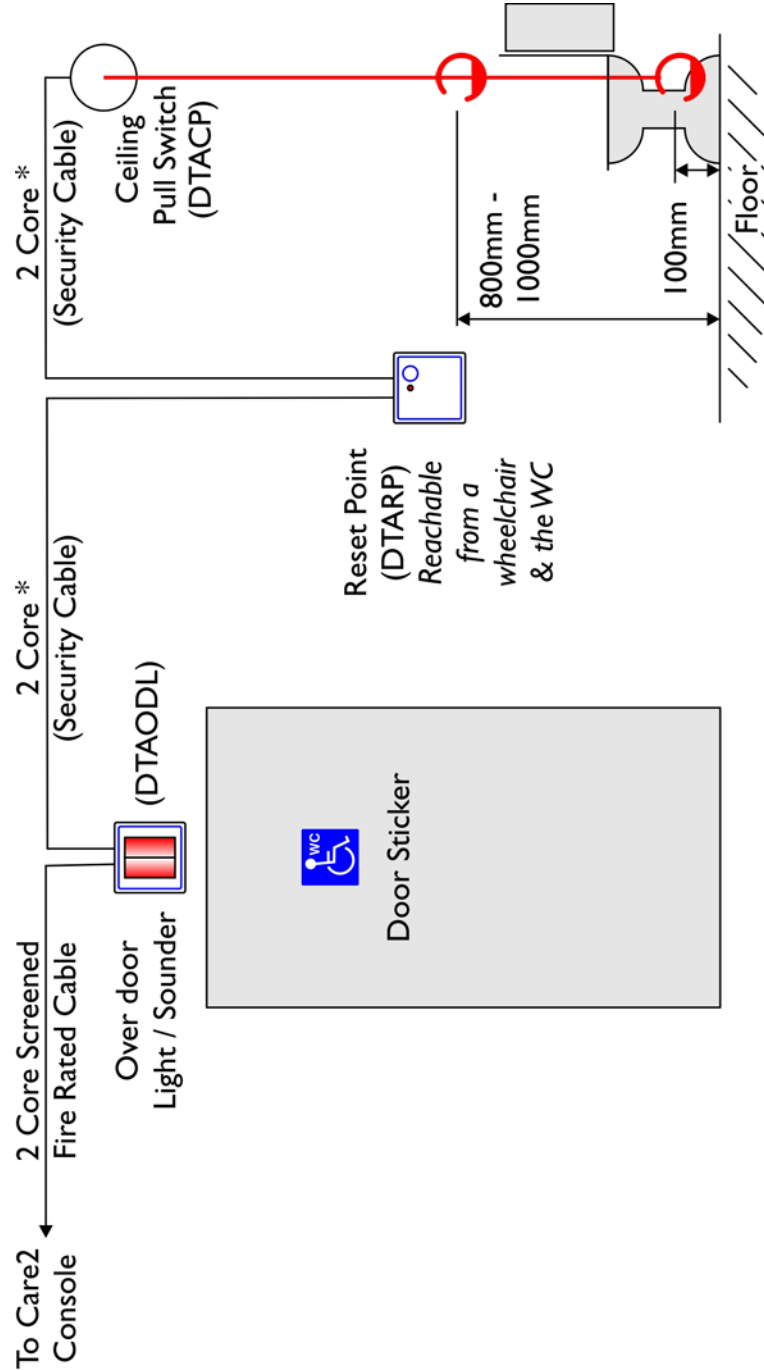

\* The Safety Earth connection **MUST** be fitted if Stainless Steel front panels or metal back boxes are used.



*NOTE: The Over Door Light (DTAODL) and Reset Point (DTARP) should be installed in suitable back boxes. Back Boxes are not supplied.*

## 2.8.2 Connection Details

The connection between the Console and the Over Door Light should be wired using Fire Rated two core cable.

The connections between the Over Door Light, the Reset Panel and the Ceiling Pull Cord should be wired using suitable Security Alarm Cable.

Figure 2.35 — DTAKIT Connection Details

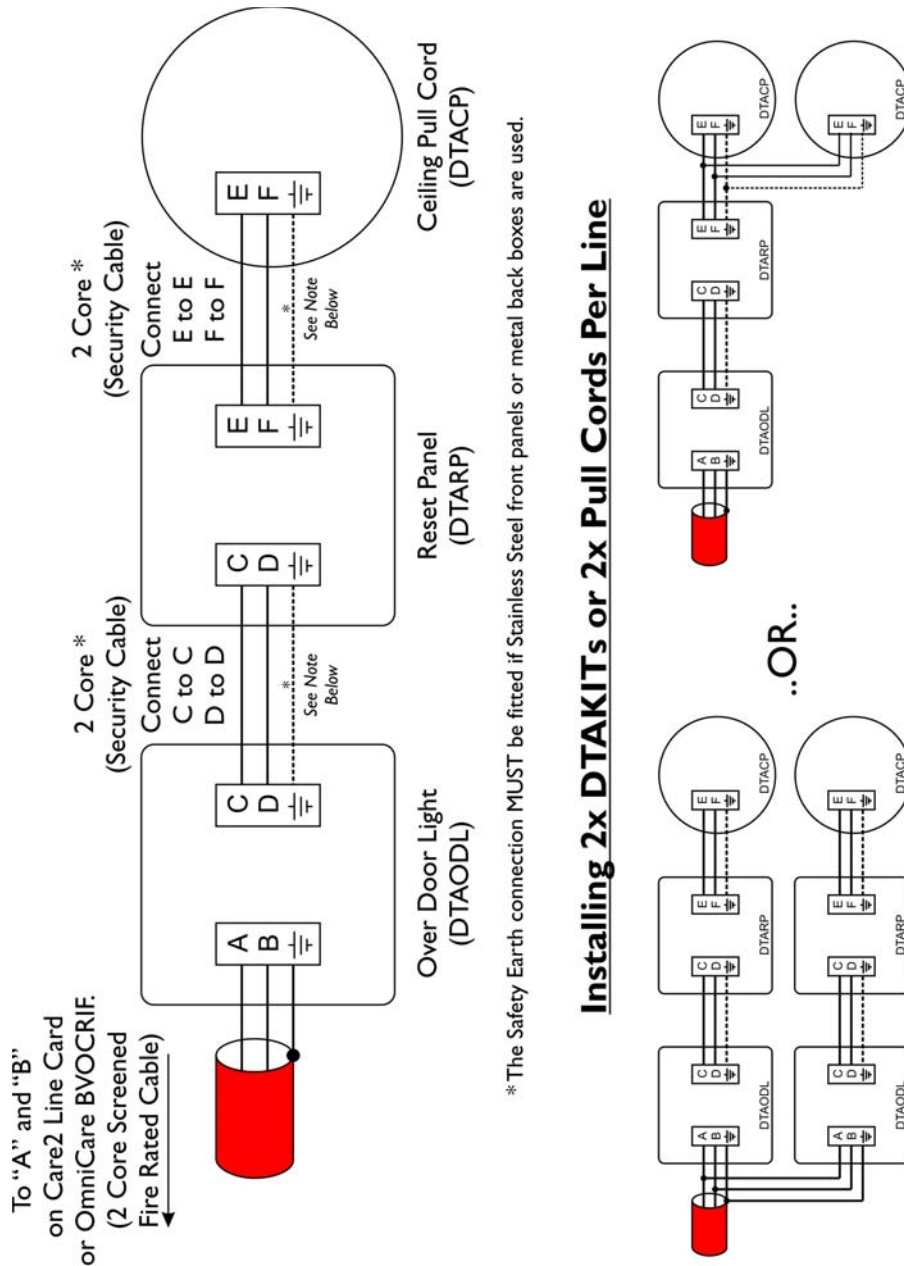

## 2.9 JACK SOCKETS

### 2.9.1 Mounting Details

The Jack Socket should be mounted in a suitable single gang backbox, deep enough to ensure the PCB & terminations will not be damaged when the plate is fitted in place.

### 2.9.2 Connection Details

Figure 2.36 — Site Wiring Connections for Jack Socket

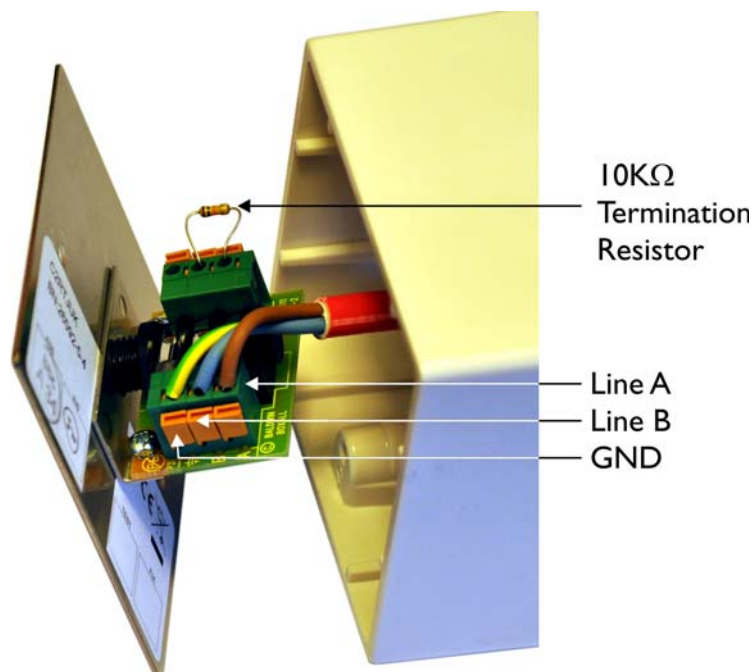

The termination blocks on the Jack Socket Plate are “Cage Clamp” terminals to enable quick and secure connections.

The Jack Socket Plates are supplied with a 10KΩ termination resistor fitted. This resistor must be fitted to enable the Console to detect and monitor the jack socket.



*NOTE: If multiple jack sockets are connected in a daisy chain arrangement then the termination resistor **MUST ONLY** be fitted to the final unit.*



## 3 Controls & Indicators

### 3.1 LCD DISPLAY & MULTI-FUNCTION ENCODER

Figure 3.1 — LCD Display & Multi-Function Encoder

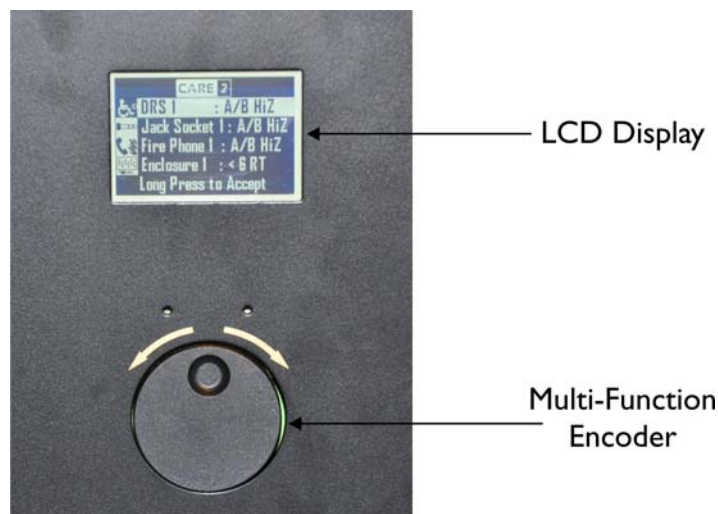

The LCD Display shows the current status of the system, indicates incoming calls and can be used for basic configuration

The Encoder is used to scroll through the menu to Make or Answer Calls (see section 6.1 on page 71), make Configuration changes (see section 4.6 on page 49) and accept faults (see section 7.1 on page 79).

## 3.2 FRONT PANEL LED INDICATORS

Figure 3.2 — Console LED Indicators

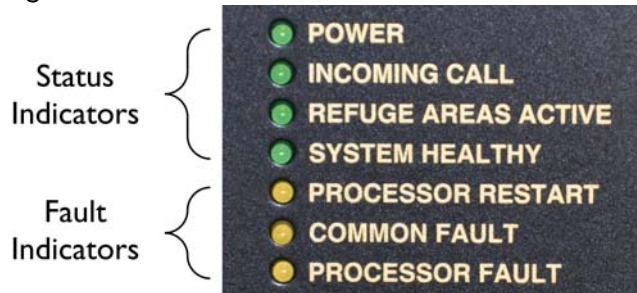

Legend	Description
Power	Illuminates when Panel has either 24V Battery or Mains Supply
Incoming Call	Flashes to indicate Incoming Call
Refuge Areas Active	Illuminates when DRS Refuge Remotes are active
System Healthy	Illuminates when no Faults are present
Processor Restart (Fault)	Illuminates after the Processor has restarted
Common Fault	Illuminates if any fault is detected
Processor Fault	Illuminates if the system detects a Processor fault (Note: the system may not operate correctly)

## 3.3 INTERNAL RESET BUTTONS

Figure 3.3 — Console Internal Reset Buttons

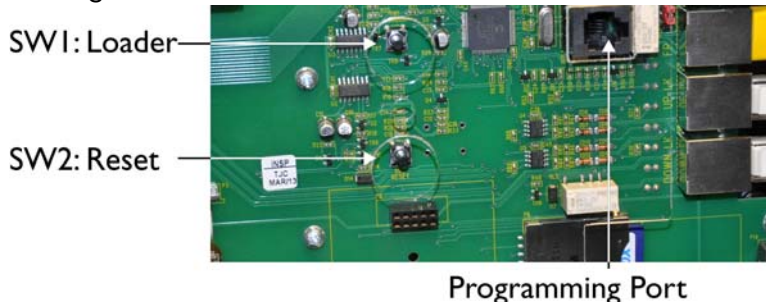

	Press & Hold	Press & Release	Release
<b>Device Detection</b>	SW1	SW2	SW1
<b>System Reset</b>	SW2	SW1	SW2

## 3.4 BATTERY CONNECT (IF MAINS POWER UNAVAILABLE)

If Mains power is not available press SW1 (Battery Connect) on the internal PSU to power the Console from batteries.

### 3.5 DRS REMOTE CONTROLS & INDICATORS

Figure 3.4 — DRS Front Panel Indicators

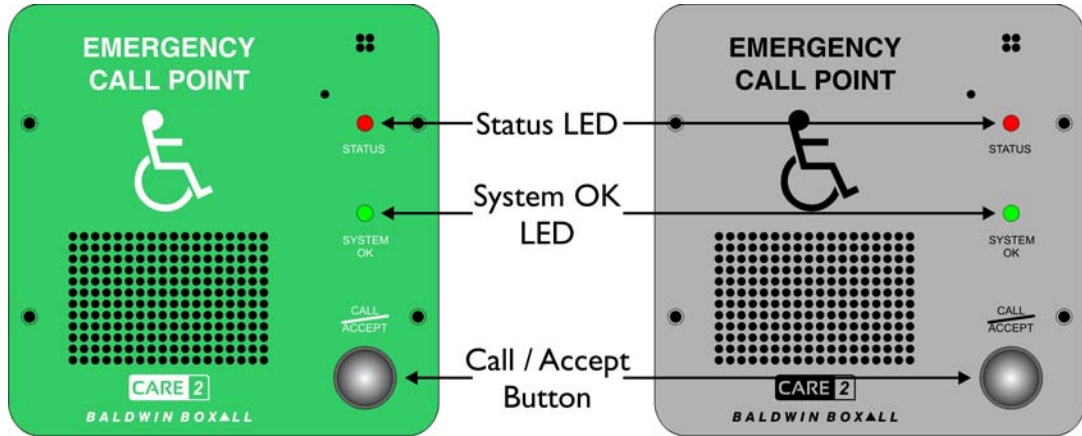

Ident	Description
Status (Red LED)	Steady ON - Currently making a call Flashing with ringtone - unit is being called
System OK (Green LED)	Flashing every 5 seconds - System in Standby Steady ON - System Active & Ready for use
Call / Accept (Button)	Press once to make a call or accept an incoming call

Figure 3.5 — DRS Internal Gain Control

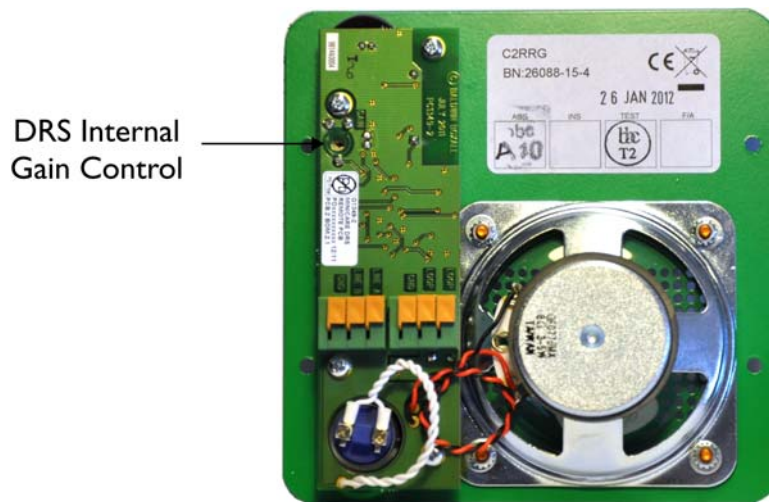

The Gain Control is adjusted during Commissioning to ensure the volume level is suitable for the installation.

## 3.6 FIRE / EMERGENCY TELEPHONE

Figure 3.6 — Fire / Emergency Telephone Status Indicator



The Status LED illuminates to show the unit is powered and ready for use. The LED will extinguish when the door is opened.

## 3.7 ROAMING HANDSET ENCLOSURE

Figure 3.7 — Roaming Handset Status LEDs



The Handset Status LEDs indicate each handset is powered and ready for use.

## 4 Commissioning

The Commissioning Procedure consists of two main sections: ensuring the Hardware is connected to each Console, and then using software to configure the Console(s) for correct operation.

### 4.1 BASIC HARDWARE COMMISSIONING PROCEDURE

1. Fit the C2CEK4 Line Cards, C2CFPE Fire Panel Interface & C2CN Network card if required.  
Refer to Section 2.2, Section 2.3 and Section 2.4 (page 13 - page 23) for installation details.
2. Connect the Outstations to the Line Cards (see Section 2.1.2 on page 12).



*NOTE: Do not connect the Site Network cables at this time.*

---

3. Apply Power using either Mains or the internal Batteries.
4. Clear Device Assignments (see Section 7.6 on page 81).
5. While the Control Panel is booting up, initiate the Internal Device Detection procedure (see Section 4.4 on page 43) and ensure it is successful.

6. The Console will then require a System Reset (see Section 4.4 on page 43).
7. Ensure the correct number of **Local** outstations are detected by the system.

*Note: All outstations will be reported as DRS units by default.*



*NOTE: It is possible to perform a basic functionality check on each outstation to ensure the audio path is correct .*



*NOTE: It is possible to perform the basic functionality check on NEP Consoles if a Roaming Handset (C2RTH) is plugged into the front panel. The NEP will automatically detect the C2RTH Handset and allow the console to answer incoming LOCAL calls.*

*On removal, the NEP will announce a fault as the handset is being monitored.*

*The Console Handset must be changed to "None" after testing is complete and the handset is removed. See section 4.6 on page 49 for details on changing the Console Handset.*

---

## 8. **For Networked Systems:**

Repeat steps (1) to (7) for each Console on the network.



*Note: Do not connect the site Network Cables to the C2CN at this time.*

---

## 4.2 MASTER / SLAVE / NEP INDICATOR

### 4.2.1 "Master" (or Non-networked) Console

Figure 4.1 — Icon Indicating "Master" Console

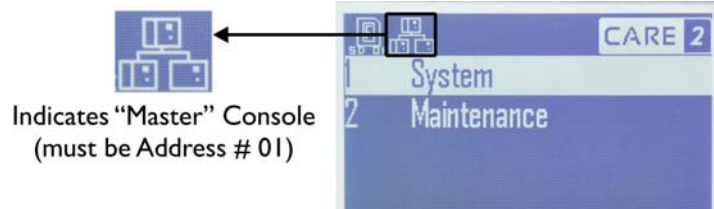

*NOTE: If a C2CN Network is detected the default is "Slave" console, otherwise the default setting is "Master" console.*

### 4.2.2 "Slave" Console

Figure 4.2 — Icon Indicating "Slave" Console

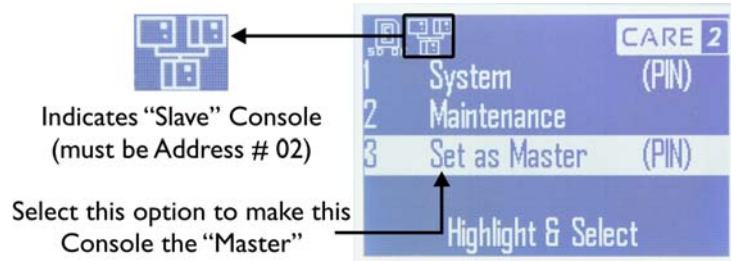

*Note: After completing the "Internal Device Detection" procedure select option (3) as shown above on the Master Console.  
The Master and Slave Consoles are toggled using this option.*

### 4.2.3 "NEP" Console

Figure 4.3 — Icon Indicating "NEP" Console

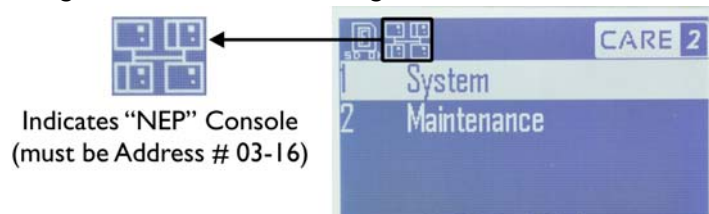

*NOTE: This option is automatically selected if "CH Type": None is entered into the Console configuration and a Handset is not detected.*

## 4.3 SOFTWARE COMMISSIONING PROCEDURES

### 4.3.1 Initial Commissioning using SD CARD

*For the MASTER Console or a Single Non-networked Console:*

1. Ensure the Basic Hardware Commissioning Procedure shown in Section 4.1 is completed successfully.
2. Disconnect the Power to the Console & remove the SD Card.
3. Insert the SD card into a PC running the SD Configurator Spreadsheet.
4. Set the correct Data Path for the SD Card (see Section 5.2.4 on page 61).
5. Fill in details for ALL Outstations on the System and not just Local Outstations on the Master Console (see Section 5.2.2 and Section 5.2.3 on page 59).
6. **Ensure the Master Console (Console #1) is selected on the ConsoleConfig Page.**  
Complete the Configuration details for the Master Console (see Section 5.2.1 on page 58).
7. Save the spreadsheet (identifiable as the Master Console spreadsheet) to a known location as this contains the configuration data for all the outstations and **the settings specific to the Master Console.**
8. Select the “Save ALL Config / Data” to SD Card option (see Section 5.2.6 on page 61).
9. Using the USB options on the PC, eject the SD Card to enable safe removal of the device then remove the SD Card.
10. Ensure the Console is not switched on & insert the SD Card. Apply Power using either Mains or the internal Batteries.
11. Clear Device Assignments (see Section 7.6 on page 81).
12. Initiate the Internal Device Detection procedure (see Section 4.4 on page 43) and ensure it is successful.

***For the SLAVE Console & All NEP Consoles:***

1. Ensure the Basic Hardware Commissioning Procedure shown in Section 4.1 is completed successfully.
2. Disconnect the Power to the Console & remove the SD Card.
3. Insert the SD card into a PC running the SD Configurator Spreadsheet.
4. Set the correct Data Path for the SD Card (see Section 5.2.4 on page 61).
5. Load either the “Master” console configuration spreadsheet (as saved in step (7) of the Master Console Commissioning procedure), or the Console Specific spreadsheet if it is available.
6. In “Console Address” select the relevant Console Number (see Section 5.2.1 on page 58).
7. Complete the Configuration details for the Slave (or NEP) Console (see Section 5.2.1 on page 58).
8. Save the spreadsheet (identifiable as the relevant Slave or NEP console) to a known location as this contains the configuration data for all the outstations and **the settings specific to the Relevant Console.**
9. Select the “Save ALL Config / Data” to SD Card option (see Section 5.2.6 on page 61).
10. Using the USB options on the PC, eject the SD Card to enable safe removal of the device then remove the SD Card.
11. Ensure the Console is not switched on & insert the SD Card. Apply Power using either Mains or the internal Batteries.
12. Clear Device Assignments (see Section 7.6 on page 81).
13. Initiate the Internal Device Detection procedure (see Section 4.4 on page 43) and ensure it is successful.
14. Connect the local Network Connections (see Section 2.4.2 on page 22) to the network card.
15. Repeat steps (1) to (14) for the Slave & all NEP Consoles.



*Note: Perform a System Reset on the MASTER Control Panel after all other panels are configured and connected.*

---

## 4.3.2 Commissioning Using Ethernet (IP) Method

*For the MASTER Console or a Single Non-networked Console:*

1. Ensure the Basic Hardware Commissioning Procedure shown in Section 4.1 is completed successfully.
2. Add Alternative IP Configuration to the PC (see Section 5.3.2 or Section 5.3.3 on page 63).



*NOTE: The Alternative IP Configuration only needs to be setup once as it will be stored within Windows.*

---

3. Connect the Console to the PC running the IP Configurator Spreadsheet using a standard RJ45 lead.  
The Ethernet Port is the top connector on the back of the Console PCB marked with a green dot.



*NOTE: Depending on the age of the PC, a "Cross-over" RJ45 lead may be required instead of a standard RJ45 lead.*

---

4. Select the “Connect and LOAD ALL Config Data from Console” option (see Section 5.3.4 on page 69).
5. Fill in details for ALL Outstations on the System and not just Local Outstations on the Master Console (see Section 5.2.2 and Section 5.2.3 on page 59).
6. **Ensure the Master Console (Console #1) is selected on the ConsoleConfig Page.**  
Complete the Configuration details for the Master Console (see Section 5.2.1 on page 58).
7. Save the spreadsheet (identifiable as the Master Console spreadsheet) to a known location as this contains the configuration data for all the outstations and **the settings specific to the Master Console.**
8. Select the “Connect and SAVE ALL Config Data to Console” (see Section 5.3.4 on page 69).
9. Clear Device Assignments (see Section 7.6 on page 81).
10. Initiate the Internal Device Detection procedure (see Section 4.4 on page 43) and ensure it is successful.

11. Connect the local Network Connections (see Section 2.4.2 on page 22) to the network card.
12. Repeat steps (1) to (14) for the Slave & all NEP Consoles.



*Note: Perform a System Reset on the MASTER Control Panel after all other panels are configured and connected.*

---

### **For the SLAVE Console & All NEP Consoles:**

1. Ensure the Basic Hardware Commissioning Procedure shown in Section 4.1 is completed successfully.
2. Ensure the Alternative IP Configuration has been added to the PC.
3. Connect the Console to the PC using a standard RJ45 lead. The Ethernet Port is the top connector on the back of the Console PCB marked with a green dot.



*NOTE: Depending on the age of the PC, a "Cross-over" RJ45 lead may be required instead of a standard RJ45 lead.*

---

4. Load the IP Configuration spreadsheet that contains the configuration data for the system (i.e. the spreadsheet previously saved in step 7 of the Master Console procedure).



*NOTE: The saved Spreadsheet MUST contain valid configuration data for the complete system.*

---

5. In “Console Address” select the relevant Console Number (see Section 5.3.4 on page 69).
6. Complete the Configuration details for the Slave (or NEP) Console (see Section 5.3.4 on page 69).
7. Save the spreadsheet (identifiable as the relevant Slave or NEP console) to a known location as this contains the configuration data for all the outstations and **the settings specific to the Relevant Console.**
8. Select the “Connect and SAVE ALL Config Data to Console” (see Section 5.3.4 on page 69).
9. Repeat steps (1) to (6) for the Slave & all NEP Consoles.
10. Clear Device Assignments (see Section 7.6 on page 81).

11. Initiate the Internal Device Detection procedure (see Section 4.4 on page 43) and ensure it is successful.
12. Connect the local Network Connections (see Section 2.4.2 on page 22) to the network card.
13. Repeat steps (1) to (12) for the Slave & all NEP Consoles.



*Note: Perform a System Reset on the MASTER Control Panel after all other panels are configured and connected.*

---

## 4.4 INTERNAL DEVICE DETECTION PROCEDURE



*NOTE: Always "Clear Device Assignments" (see Section 7.6 on page 81) before running the Device Detection Procedure.*

*NOTE: This procedure is necessary during Commissioning, if a Line Card (C2CKE4) or a Network Card (C2CN) has been added, or if a faulty card is replaced within the Console.*

*This procedure also writes the Network Address to the Network Card (see Section 2.4.1 on page 21).*

*Network Cables MUST be disconnected for this procedure.*

1. Connect the 230V Mains Supply to the Console.
2. On the rear of the Front Panel SW1 & 2 are used to initiate the Device Detection Routine or perform a System Reset.

Figure 4.4 — Internal Reset & Loader Buttons

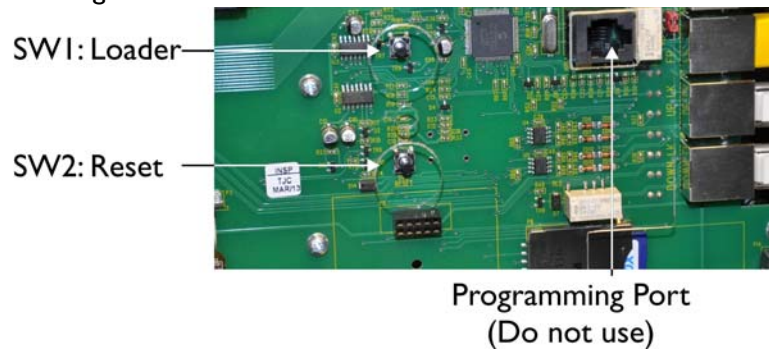

	Press & Hold	Press & Release	Release
<b>Device Detection</b>	SW1	SW2	SW1
<b>System Reset</b>	SW2	SW1	SW2

To perform the Device Detection Procedure, press & hold SW1, press & release SW2, then release SW1.

3. The Front Panel Display should indicate the system is in Device Detection Mode as shown in Figure 4.5.

Figure 4.5 — LCD Display showing Device Detection

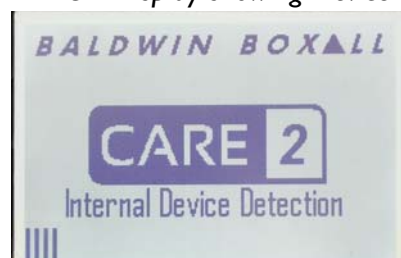

The progress bar indicates that the Console is searching for Devices (Line Cards and Network Card).

4. When the system has completed the Detection Routine the display will change to show “System Reset Required” and either “Success” or “Failure” as shown in Figure 4.6 and Figure 4.7.

Figure 4.6 — Device Detection Success



If the Device Detection was successful then perform a System Reset and continue with the Commissioning procedure.

Figure 4.7 — Device Detection Failure

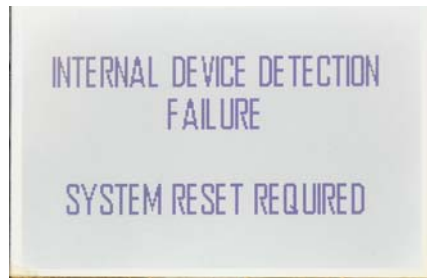

If the Device Detection failed then check all connections between the Front Panel and the Line Cards (including Link Leads), and ensure the Uplink & Downlink cables are connected correctly. Restart the Device Detection Procedure after checking all Connections.



---

*NOTE: The C2CN Network card must be DISCONNECTED from the Site Network Cabling before starting the Internal Device Detection procedure. The C2CN may not be correctly detected if the Site Network Cabling is left connected.*

---

## 4.5 AUTO ASSIGN OUTSTATIONS



*NOTE: When the Console boots up this procedure is performed automatically and the Console will ADD new Outstations.*

*Manually initiating this procedure enables the Console to REMOVE outstations that are not connected.*

1. Ensure the Console Telephone Door is closed and latched.
2. The Display may be showing the Screen Saver as shown in Figure 4.8.

Figure 4.8 — Display showing Screen Saver.



Move the encoder so the display becomes active and displays the Main Menu as shown in Figure 4.9.

Figure 4.9 — Display showing Main Menu



3. Press the encoder to select the “System” option.

Figure 4.10 — Enter PIN number

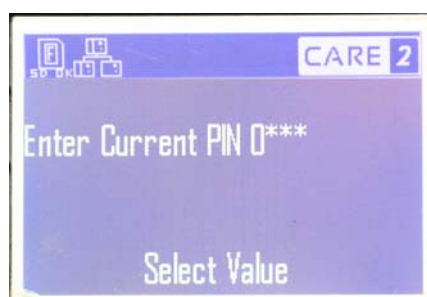

The system will ask for a PIN number.  
The default PIN is 5555.

4. The System Menu will then be displayed.

Figure 4.11 — Display showing System Menu



5. Scroll up to the “Line Parameters” option.

Figure 4.12 — Selecting Line Parameters Option



6. Select “Line Parameters” and the Line Parameters Menu will be displayed.



*NOTE: On the Master Console in a networked system there is an extra screen showing all consoles on the system, and the operator can choose which console is to be selected.*

*Consoles with configuration information are shown with a "+".*

Figure 4.13 — Console Selection Option (Shown on Master Console Only)



Figure 4.14 — Typical Line Parameters Menu (Local Console selected)



7. Scroll up to the “Auto Assign” option.



*NOTE: The Auto Assign procedure can only be initiated on the Local Console.*

Figure 4.15 — Selecting Auto Assign Option



8. Select “Auto Assign” and the following warning will be displayed.

Figure 4.16 — Auto Assign Data Modification warning



*NOTE: At any time it is possible to "Escape" to the Exit Entry in the current menu by Pressing and Holding the Encoder.*

*This "Long Press" will cancel the Auto Assign process.*

Press the Encoder to initiate the “Auto Assign” process.

The Console will then interrogate each line in turn.

If a new Outstation is found the Console will store the data in the Line Parameters menu.

If a previously detected Outstation is not found then the (Manually Selected) Auto Assign process will replace the outstation type with “N/A”.

9. In the following example Outstation 3 has not been found.

Figure 4.17 — Line Parameters Menu after Manual Auto Assign



10. Scroll down through the Line Parameters Menu and ensure the number of Outstations found matches the number of Remote Units installed on the system.

If any Remote Units are missing from the list then the connections between the Console and the Remote Unit(s) should be checked for continuity.

The Auto Assign Procedure should then be repeated.

11. When complete select “Exit” to return to the System Menu.

## 4.6 MANUALLY SPECIFY OUTSTATION TYPE



*NOTE: The Outstation Type is normally specified during the SD or IP Configuration. This procedure shows how to manually specify the outstation type using the front panel controls.*

Follow steps (1) to (6) of the Auto Assign Procedure (page 45) to open the “Line Parameters” menu.

1. Select the line required (in this example Outstation 1) and the parameters for that line will be displayed.

Figure 4.18 — Line Parameters for Outstation 1



2. Press the Encoder to change the icon of the Outstation to match the Remote Unit in use.

The available Icons are:

	Console Handset
	Stewards Telephone
	Fire Telephone
	Disabled Refuge Remote
	Disabled Toilet Alarm x1 (Single Pullcord)
	Disabled Toilet Alarm x 2 (Dual Pullcords)
	Roaming Telephone Jack Socket
	Roaming Telephone Enclosure
	Disable Refuge with Firephone (Future Use)

3. Scroll up or down to highlight the Icon suitable for the Remote Unit in use.
4. Press the Encoder to store the correct Icon.

5. Repeat steps (1) to (4) for all the lines in use.



*NOTE: It is important the system is correctly configured with the correct Outstations identified on each Line.*

*The Console uses this information to configure the features and functions available for the different types of Outstation.*

*If "DTA x2" is selected the EOLz OC (End Of Line Impedance Open Circuit) value is automatically adjusted to monitor Two Units.*

*If the Roaming Handset Enclosure is selected the EOLz OC value must be entered manually - see Section 4.8 on page 53 for details.*

6. When all Lines and Outstations are correctly configured scroll up until "Save and Exit" is displayed.

Figure 4.19 — Save and Exit Outstation 1 Parameters



Press the Encoder to save the changes made.



*NOTE: To Exit without saving the changes select "Exit Without Save" and press the encoder.*

## 4.7 MANUALLY RENAME REMOTE UNITS



*NOTE: The Outstation Names are normally specified during the SD or IP Configuration. This procedure shows how to manually change the outstation name using the front panel controls.*

Follow steps (1) to (6) of the Auto Assign Procedure (page 45) to open the “Line Parameters” menu.

1. Select the line required (in this example Outstation 1) and the parameters for that line will be displayed.

Figure 4.20 — Line Parameters for Outstation 1



2. Scroll down until the name is selected and press the encoder.

Figure 4.21 — Current Name of Line 1 Highlighted



Scroll up and down to change each character in turn and press the encoder to move onto the next character.

Figure 4.22 — Renaming Line 1

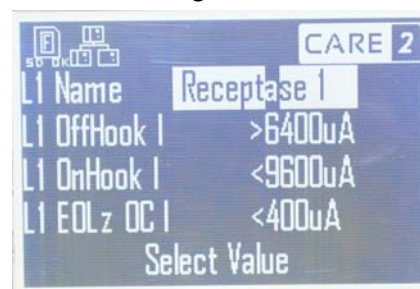

- When finished renaming the Outstations, scroll up until “Save and Exit” is displayed.

Figure 4.23 — Save and Exit Outstation I Parameters



Press the Encoder to save the changes made.



*NOTE: The name length for each Outstation is 13 Characters. Add blank spaces if required to ensure the name is the correct length.*



*NOTE: To Exit without saving the changes select "Exit Without Save" and press the encoder.*

## 4.7.1 ASCII Character Set

Figure 4.24 — ASCII Character Set showing Character Order

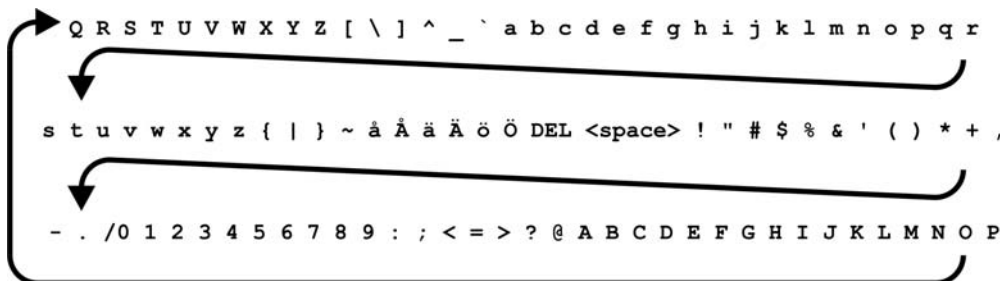

Figure 4.24 shows the order of the characters when the encoder is turned Clockwise.

The “DEL” character (when selected) allows the operator to go back a single character to change it.

## 4.8 ROAMING TELEPHONE ENCLOSURE SPECIFIC PARAMETERS

The Console monitors the handsets within the Enclosure and will announce a Warning if a Handset is removed, but it is necessary to set the threshold for the number of handsets in use.

1. Follow steps (1) to (6) of the Auto Assign Procedure (page 45) to open the “Line Parameters” menu.

Figure 4.25 — Line Parameters Menu showing Lines 1-4



2. Scroll up or down to highlight the Line with the Enclosure (Line 2 in this example).

Figure 4.26 — Highlight the Required Line

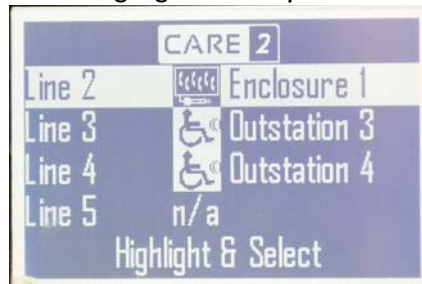

3. Press the encoder and the parameters for that Line will then be displayed.

Figure 4.27 — Parameters for Line 2

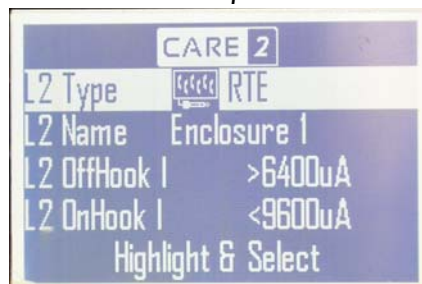

4. Scroll down until EOLz OC (End Of Line Impedance Open Circuit) value is shown, and press the encoder.

The default value for a single Roaming Handset is 400uA.

Figure 4.28 — EOL Impedance value selected



5. Scroll up until the value shown matches that indicated in Table 4.1 for the number of handsets stored in the Enclosure.

Table 4.1 — End Of Line Values for Handset Enclosure

Number of Handsets Stored in Enclosure	Required EOL OC Value
1	< 400uA
2	< 1300uA
3	< 2150uA
4	< 3050uA
5	< 3900uA
6	< 4800uA

6. When the EOL Value is correct for the number of handsets in use press the encoder.
7. Scroll down to “Save and Exit”.
8. Press the encoder to save the changes and exit the Line 2 Menu.

## 4.9 SYSTEM MENU STRUCTURE

Title	Description
Change PIN	Change the PIN to access the System Menu
Local System Status	View the Status of the Local Console
Local Device Status	View the Status of the Local Internal Devices
Local Line Status	View the Status of each Line of the Console
Vendor Details	View and Change the Vendor Contact details
System Parameters	View and Adjust settings relating to the system
Line Parameters	View and adjust settings relating to the Line and relevant Outstation
RTC Adjustment	Set the Real Time Clock
Exit	Exit from System Menu

### 4.9.1 System Parameters

Title	Default Value	Description
Local Address	1	Sets the Network Address of the Local Panel
DTA Resettable	No	Reset Active DTA calls from Console
BBU Monitored	Yes	Battery Backup Fault Monitoring
DRS Enable	N-Open	** DRS Enable Contacts set to Normally Open **
DRS PF Enable	Yes	Enable DRS Remote Units on Mains Power Failure
RTC in ScnSvr	No	Show Real Time Clock on ScreenSaver
Fault Silence	No	Temporarily disable Fault Sounder
IC Call Silence	No	Temporarily disable Incoming Call Sounder
Silence Timeout	480mins	Timeout before Fault & Incoming Call Sounders are reactivated
LCD Timeout	60secs	Timeout for LCD to return to Screensaver
LCD Contrast	37%	LCD contrast
Fault Repeat	480mins	Timeout before Faults are reannounced
Warning Repeat	720mins	Timeout before Warnings are reannounced
CH Type	CH	Type of Console Handset on Local Console
CH Name	Main Console	Name of local Console
CH Offhook I	>1600uA	Threshold for Handset Offhook
CH Onhook I	<9600uA	Threshold for Handset Onhook
CH EOLz OC I	<400uA	Threshold for Open Circuit Handset Fault
CH EOLz SC I	>46400uA	Threshold for Short Circuit Handset Fault
Restore Defaults	N/A	Restore All System Settings to Default Values
Exit		Exit System Parameters Menu
** This setting must be set to N-Closed when a Fire Panel Interface is required		

## 4.9.2 Line Parameters

Title	Default Value	Description
Type	none / DRS	Will display "none" if Outstation not detected, will default to "DRS" if an Outstation is detected. To ensure correct operation the Installer must select the type of Outstation attached to the Line.
Name	Outstation n	Name of the Outstation
Ln Offhook I	>6400uA	Threshold for Outstation Offhook
Ln Onhook I	<9600uA	Threshold for Outstation Onhook
Ln EOLz OC I	<400uA	Threshold for Open Circuit Outstation Fault
CH EOLz SC I	>48800uA	Threshold for Short Circuit Outstation Fault
Restore Defaults	N/A	Restore All Line Parameters to Default Values
Save and Exit		Save Changes and Exit Line Parameters Menu
Exit Without Save		Exit Line Parameters Menu Without Saving

## 4.9.3 RTC (Real Time Clock) Adjustment

The RTC (Real Time Clock) is used to Date & Time stamp entries in the Fault Log and should be set to the current time when the system is commissioned.

### 4.9.3.1 Real Time Clock PEC (Processor Error Correction)

The Real Time Clock is adjusted by setting PEC values, these are factory preset and should not require adjustment.

The default settings for this combination of Hardware & Firmware is as follows:

Table 4.2 — Default PEC Settings for Real Time Clock

PEC Setting	PEC Value
PEC per Minute	-11
PEC per Hour	34
PEC per Day	12

### 4.9.3.2 RTC Power Requirements



*NOTE: If power is completely removed (i.e.both Mains and 24V Battery Supply are disconnected) the RTC will stop running.*

*When power is restored the RTC will re-start, however it will require re-setting to the current time.*

# 5 SD and IP Configuration

## 5.1 CONFIGURATION OVERVIEW

The Configuration settings for Care2 are stored within each Console on an SD (SDSC) Card (maximum capacity 1GB).



*NOTE: Only SD Cards correctly formatted by a Console can be used to store Configuration Data.*

*The SD cards can be read and written by PCs but use a specific FAT16 file format that is different to MS Windows standard FAT16 format.*



### CAUTION

The Console will detect an incorrectly formatted SD card during the boot process and will attempt to format the card. All existing user data on the card will be deleted.

Configuration details can be entered directly via the Front Panel of each Console, however on networked systems it is recommended to use either the SD Card or IP (Ethernet) Configuration Software.

The data stored on each SD Card includes console specific data (each Console SD Card is different) and also data for the outstations on the system.

Both SD & IP Configurators are based on a Microsoft Excel Spreadsheet and this application is required to open the files.

## 5.2 SD CARD CONFIGURATOR

The SD Card Configurator has four pages, and each page is described in the following sections.

### 5.2.1 SD Card “ConsoleConfig” Page

This shows Configuration Data for the selected Console.

Figure 5.1 — SD ConsoleConfig Page - Console Configuration Details

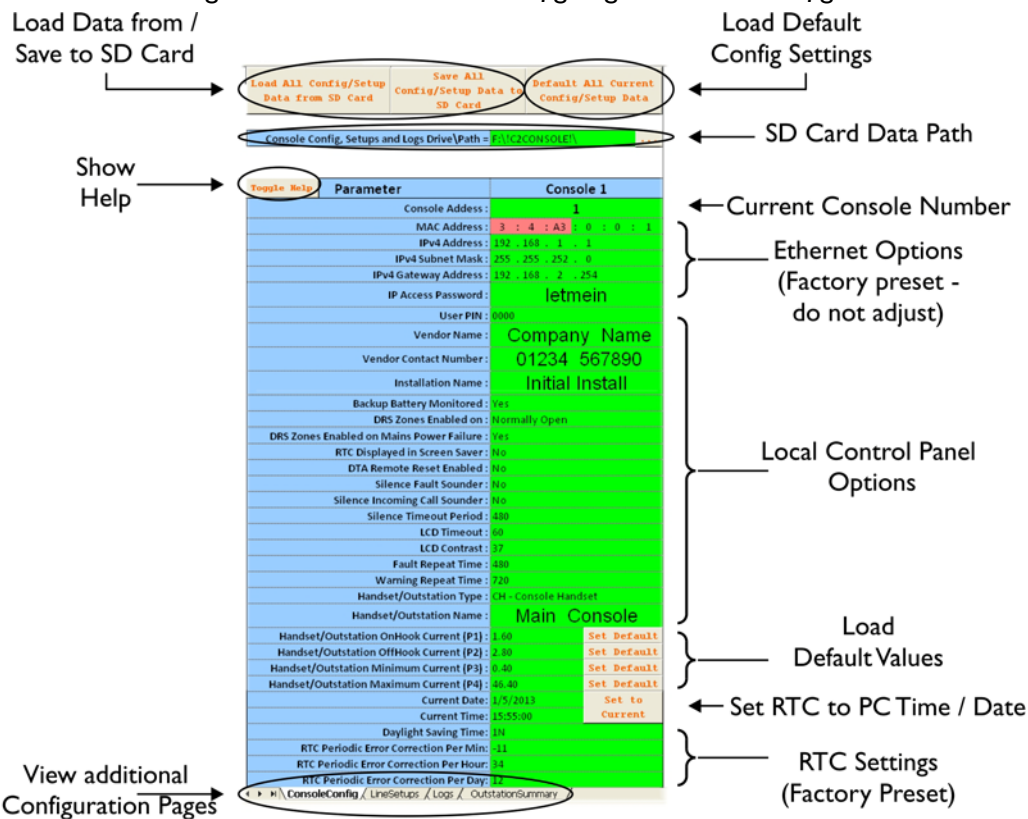

Title	Description
Load Data from / Save to SD Card	Buttons allow the operator to load a Configuration from the SD Card, and to save the current Configuration to the SD Card
Show Help	Shows (or hides) the Help view
View Additional Config Pages	Switches to show additional Configuration Pages
Load Default Config Settings	Loads Default settings for ALL Console & Handset options
SD Card Data Path	Displays the current path for SD Card Loading / Saving
Current Console Number	Shows the Console Number for the Data being displayed: Select the required Console from the dropdown menu
Ethernet Options	Factory Preset (Do not adjust - sets the address for connecting via IP)
Local Console Options	Settings for the Local Console
Load Default Values	Load Default options for Handset Monitoring
Set to Current RTC	Load Real Time Clock settings from the PC
RTC Settings	Real Time Clock Settings (Factory Preset)



*NOTE: The name length for Vendor, Contact & Installation is 15 Characters. Add spaces if required to ensure the name is the correct length.*

## 5.2.2 SD Card “LineSetups” Page

Figure 5.2 — LineSetups Page - Line Configuration for ALL Consoles  
Console #1 (A), Showing Config Details for Lines 1-5

Parameter	Current Console	1	Main Console	Line 1	Line 2	Line 3	Line 4	Line 5
Local Line Card Address :	0	0	0	0	0	0	0	0
Line Card Port Number :	0	0	0	0	0	0	0	0
Handset/Outstation Type :	none	none	none	none	none	none	none	none
Handset/Outstation Name :	OutstationA01	OutstationA02	OutstationA03	OutstationA04	OutstationA05	OutstationA06	OutstationA07	OutstationA08
Handset/Outstation Type :	none	none	none	none	none	none	none	none
Handset/Outstation Name :	OutstationB01	OutstationB02	OutstationB03	OutstationB04	OutstationB05	OutstationB06	OutstationB07	OutstationB08
Handset/Outstation Type :	none	none	none	none	none	none	none	none
Handset/Outstation Name :	OutstationC01	OutstationC02	OutstationC03	OutstationC04	OutstationC05	OutstationC06	OutstationC07	OutstationC08
Handset/Outstation Type :	none	none	none	none	none	none	none	none
Handset/Outstation Name :	OutstationD01	OutstationD02	OutstationD03	OutstationD04	OutstationD05	OutstationD06	OutstationD07	OutstationD08
Handset/Outstation Type :	none	none	none	none	none	none	none	none
Handset/Outstation Name :	OutstationE01	OutstationE02	OutstationE03	OutstationE04	OutstationE05	OutstationE06	OutstationE07	OutstationE08

Annotations in the image:  
 - Console #3 (C), Showing Config Details for Lines 1-5 (points to Console 3)  
 - Console #2 (B), Showing Config Details for Lines 1-5 (points to Console 2)  
 - Console #5 (E) to #17 (P) (points to Console 5)  
 - Scroll to the right for lines 6-16 (points to the right side of the table)  
 - Lines 6 - 16 (indicated on the right side of the table)

The LineSetups page allows the operator to enter details of ALL Lines (Outstations) on ALL Consoles.

This Global configuration data only has to be entered once regardless of how many Consoles or Outstations are in use as the relevant information is downloaded to the Console.

## 5.2.3 To Enter Handset / Outstation Data

1. Select Console 1 from the Dropdown Menu on the ConsoleAddress page.  
This ensures that Console #1 is at the top of the list on the LineSetups page.

Figure 5.3 — Selecting Console #1 on the ConsoleAddress Page

Parameter Console 1

Console Address :	1
MAC Address :	
IPv4 Address :	
IPv4 Subnet Mask :	
IPv4 Gateway Address :	
IP Access Password :	
User PIN :	0000

Select the Console Address (Console #1)

2. Switch to the LineSetups page.

3. On the LineSetups page, for Console #1 Line #1 select the type of Outstation in use from the Dropdown Menu.

Figure 5.4 — Selecting Type of Outstation for Console #1 Line #1

ter	Current Console 1	Main Console	
	Line 1	Line 2	Line 3
al Line Card Address :	0	0	0
ie Card Port Number :	0	0	0
set/Outstation Type :	none	none	none
et/Outstation Name :	OutstationA02	Outstation	
set/Outstation Type :	CH - Console Handset		
et/Outstation Name :	Slave Console		
set/Outstation Type :	ST - Stewards Telephone		
et/Outstation Name :	OutstationB02	Outstation	
set/Outstation Type :	FT - Fire Telephone		
et/Outstation Name :	OutstationB01		
set/Outstation Type :	DRS - Disabled Refuge		
et/Outstation Name :	OutstationB02	Outstation	
set/Outstation Type :	DTA1 - Single Disabled Toilet Alarm		
et/Outstation Name :	OutstationB02	Outstation	
set/Outstation Type :	DTA2 - Dual Disabled Toilet Alarm		
et/Outstation Name :	OutstationB02	Outstation	
set/Outstation Type :	RIS - Registered Jack		
et/Outstation Name :	OutstationB02	Outstation	
set/Outstation Type :	Console	3	NEP Console03
et/Outstation Name :	OutstationB02	Outstation	

Select Type of Handset / Outstation from Dropdown List (Console #1 Line #1)

4. Double-click in the box below to rename the Outstation.

Figure 5.5 — Renaming Console #1 Outstation #1

ter	Current Console 1	Main Console	
	Line 1	Line 2	Line 3
al Line Card Address :	0	0	0
ie Card Port Number :	0	0	0
set/Outstation Type :	DRS - Disabled Refuge	none	none
et/Outstation Name :	Staircase 1	OutstationA02	Outstation
set/Outstation Type :	none	Slave Console	
et/Outstation Name :	OutstationB01	OutstationB02	Outstation
set/Outstation Type :	Console	3	NEP Console03
et/Outstation Name :	OutstationB01	OutstationB02	Outstation

Double-click in the box to rename the Outstation  
Max 13 characters (Console #1 Line #1)



NOTE: The name length for each Outstation is 13 Characters. Add blank spaces if required to ensure the name is the correct length.

5. For Console #1 Line #2 select the type of Outstation in use from the Dropdown Menu.

Figure 5.6 — Selecting Type of Outstation for Console #1 Line #2

ter	Current Console 1	Main Console	
	Line 1	Line 2	Line 3
al Line Card Address :	0	0	0
ie Card Port Number :	0	0	0
set/Outstation Type :	DRS - Disabled Refuge	none	none
et/Outstation Name :	Staircase 1	Outstation	
set/Outstation Type :	Console	2	
et/Outstation Name :	OutstationB01	Outstation	
set/Outstation Type :	Console	3	NEP Console03
et/Outstation Name :	OutstationB01	Outstation	

Select Type of Handset / Outstation from Dropdown List (Console #1 Line #2)

6. Double-click in the box below to rename the Outstation.

Figure 5.7 — Renaming Console #1 Outstation #2

ter	Current Console 1	Main Console	
	Line 1	Line 2	Line 3
al Line Card Address :	0	0	0
ie Card Port Number :	0	0	0
set/Outstation Type :	DRS - Disabled Refuge	DRS - Disabled Refuge	none
et/Outstation Name :	Staircase 1	Staircase 2	Outstation
set/Outstation Type :	Console	2	
et/Outstation Name :	OutstationB01	OutstationB02	Outstation
set/Outstation Type :	Console	3	NEP Console03
et/Outstation Name :	OutstationB01	OutstationB02	Outstation

Double Click in the box to rename the Outstation  
Max 13 characters (Console #1 Line #2)

7. Repeat steps (3) to (6) for each Outstation on the system, including those connected to all other Consoles.
8. When all outstations have been entered into the Configurator it is strongly suggested to save the Excel Spreadsheet to a known location.

## 5.2.4 Setting the SD Card Data Path

The Data Path for the “CONFIG\_\_.DAT” file must be specified before the SD Card can be read from or written to.

This file is created in the root directory of an SD Card when it is formatted by a Console.

The data path can be added manually, or can be located by browsing using the “..” button.



*NOTE: If the "CONFIG\_\_.DAT" file cannot be found on the SD Card then it is not correctly formatted and cannot be used. Only SD Cards pre-formatted by a Console can be used.*

## 5.2.5 Loading Configuration from an SD Card

To load configuration data from an SD Card press the “Load ALL Config / Setup...” button on the ConsoleConfig page.

All current configuration data will be overwritten.

## 5.2.6 Saving Configuration to an SD Card

To Save the current configuration to the SD Card press the “Save ALL Config / Setup...” button on the ConsoleConfig page.



*NOTE: The Console Address (shown in Figure 5.8) is used to determine the address of the Console in a Networked System. This should be set BEFORE saving the data to the relevant SD Card.*

Figure 5.8 — Selecting Console #1 on the ConsoleAddress Page

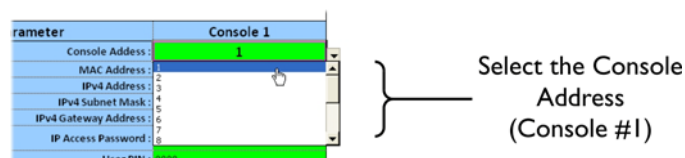

## 5.2.7 SD Card “Logs” Page

All Consoles store a Fault log for Local faults.

On networked systems, the Master console stores local faults and also a copy of all faults reported by the NEP Consoles.

Press the “Load Event / Fault Log..” button to load the fault log from the SD Card. This will overwrite the data currently shown.

Press the “Clear Even / Fault Log file on the SD Card” button to clear the fault log currently stored on the SD Card.

Press the “Clear Log Table” to clear the data being displayed.

Figure 5.9 — Typical Fault Log

Event Slot		Event Type		Event Location 1		Event Location 2		Event Date		Event Time		
Detail		Data	Detail		Data	Detail		Data	Detail		Data	
1	Processor POR Restart	4	Console 1	1	0	01/05/2013	1	5	15:55:01	15	55	1
2	Open Circuit Fault	17	Console 1	1	8	01/05/2013	1	5	16:07:44	16	7	44
3	Open Circuit Fault (Recovered)	145	Console 1	1	8	01/05/2013	1	5	16:07:52	16	7	52
4	Battery Charger Fault	10	Console 1	1	0	01/05/2013	1	5	16:08:05	16	8	5
5	Battery Charger Fault (Recovered)	138	Console 1	1	0	01/05/2013	1	5	16:08:12	16	8	12
6		0		0	0		1	1		0	0	0
7		0		0	0		1	1		0	0	0
8		0		0	0		1	1		0	0	0
9		0		0	0		1	1		0	0	0
10		0		0	0		1	1		0	0	0
11		0		0	0		1	1		0	0	0
12		0		0	0		1	1		0	0	0

## 5.2.8 “OutstationSummary” Page

The OutstationSummary Page of the Configurator shows the operator the Outstations that are set up on the System.

Figure 5.10 — Typical OutstationSummary Page

Console	Handset	Line									
		1	2	3	4	5	6	7	8	9	10
1	CH	DRS	DRS	DRS	DRS	DRS	DTA×1	DTA×1	DRS	-	-
2	-	-	-	-	-	-	-	-	-	+	-
3	-	-	-	-	-	-	-	-	-	-	-
4	-	-	-	-	-	-	-	-	-	-	-
5	-	-	-	-	-	-	-	-	-	-	-
6	-	-	-	-	-	-	-	-	-	-	-
7	-	-	-	-	-	-	-	-	-	-	-
8	-	-	-	-	-	-	-	-	-	-	-
9	-	-	-	-	-	-	-	-	-	-	-
10	-	-	-	-	-	-	-	-	-	-	-
11	-	-	-	-	-	-	-	-	-	-	-
12	-	-	-	-	-	-	-	-	-	-	-
13	-	-	-	-	-	-	-	-	-	-	-
14	-	-	-	-	-	-	-	-	-	-	-
15	-	-	-	-	-	-	-	-	-	-	-
17	-	-	-	-	-	-	-	-	-	-	-

## 5.3 IP CONFIGURATOR

### 5.3.1 Setting Alternate IP Configuration on PC

Before the IP Configurator software can communicate with a Console using TCP/IP it is necessary to set up an Alternate IP Configuration for the relevant Network Adaptor on the PC.

The Alternate IP Configuration allows the PC to connect to the Care2 Consoles using a specific configuration, without making any changes to the existing TCP/IP Configuration.

The following sections give basic instructions on setting this alternate Configuration using Windows XP and Windows 7.

### 5.3.2 Setting Alternate TCP/IP Configuration - Windows XP

1. Open the Windows XP Control Panel and open the Network Connections tab:

Figure 5.11 — Typical Windows XP Network Connections

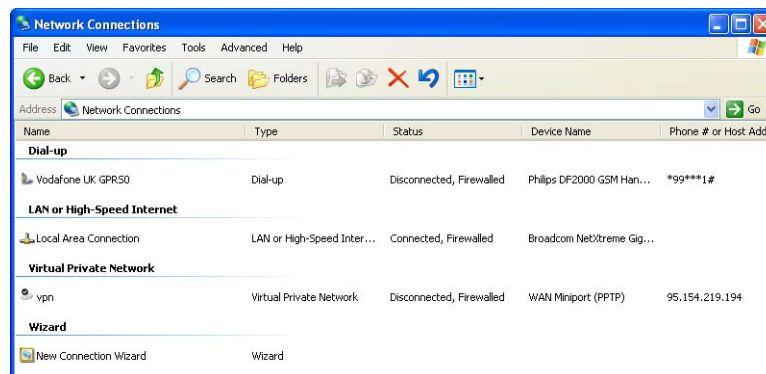

2. Under the LAN or High-Speed Internet entries, Right click on the Local Area Connection and select properties:

Figure 5.12 — Selecting Properties of the Local Area Network Connection

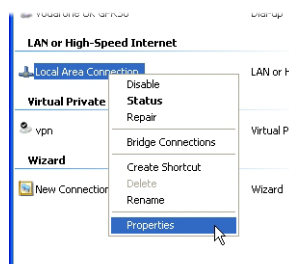

- The properties of the Local Area Connection will be displayed.  
Scroll down until the Internet Protocol (TCP/IP) is entry is displayed.  
Select Internet Protocol (TCP/IP) and then select Properties.

Figure 5.13 — Local Area Connection Internet Protocol (TCP/IP) Selected

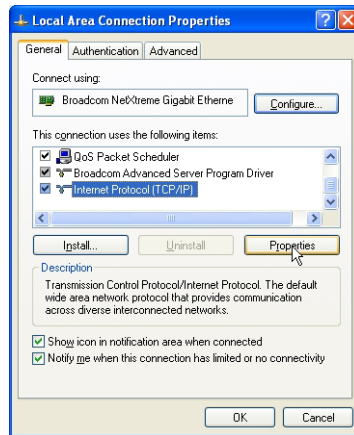

- The Internet Protocol (TCP/IP) Properties will be displayed, with the “General” tab showing.  
Select the “Alternate Configuration” tab.

Figure 5.14 — Internet Protocol Properties, General Settings Displayed

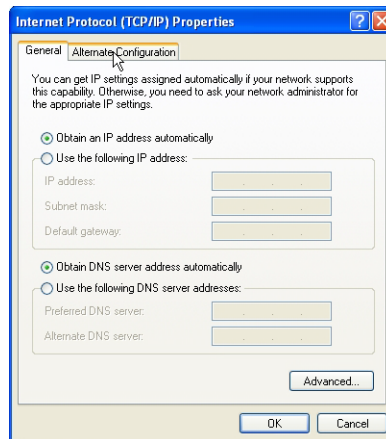

- In the Alternative Configuration Tab select “User configured” and enter the following details:

IP address: 192.168.2.1

Subnet Mask: 255.255.252.0 *Note this is NOT the auto setting*

Default Gateway: 192.168.2.254

Figure 5.15 — User Configured Alternate Configuration

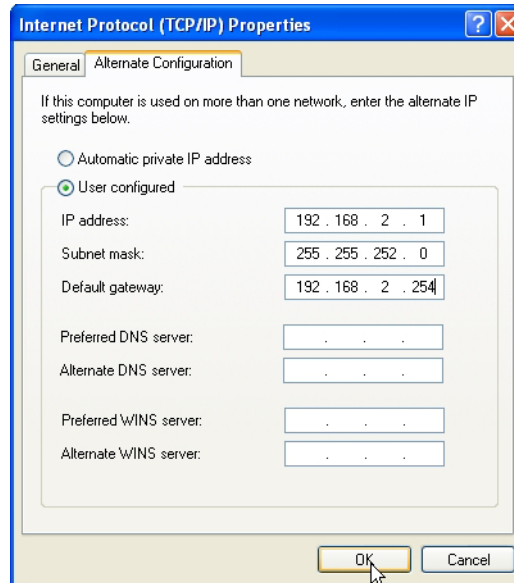

6. Select OK and the Properties box will close.  
Close the Local Area Connection Dialog box.

## 5.3.3 Setting Alternate TCP/IP Configuration - Windows 7

1. Open the Windows 7 Control Panel and open the Network and Sharing Centre window:

Figure 5.16 — Typical Windows 7 Network and Sharing Window

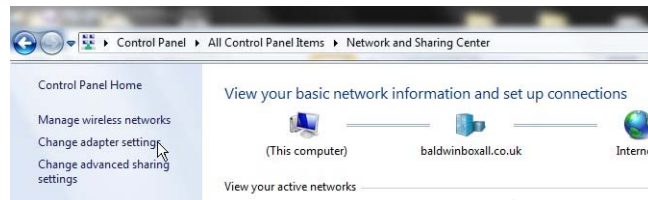

2. Click on “Change Adapter Settings” (as shown in Figure 5.16 above) and the Network Adaptors installed on the PC will be displayed.
3. Double click on the Local Area Connection icon.

Figure 5.17 — Local Area Connection Icon



4. The status of the Local Area Network will be displayed. Select “Properties” as shown below.

Figure 5.18 — Local Area Network Connection Status

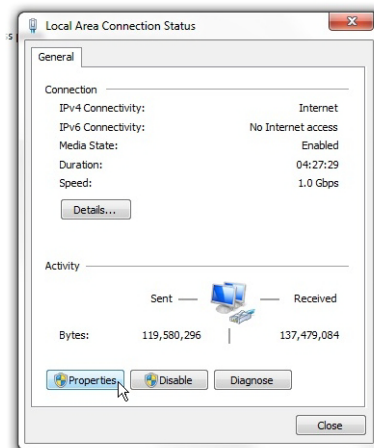

5. The Local Area Connection Properties will then be displayed. Highlight Internet Protocol Version 4 (TCP/IP) and then select Properties (don't un-check the tick).

Figure 5.19 — Local Area Connection TCP/IPv4 Properties Selected

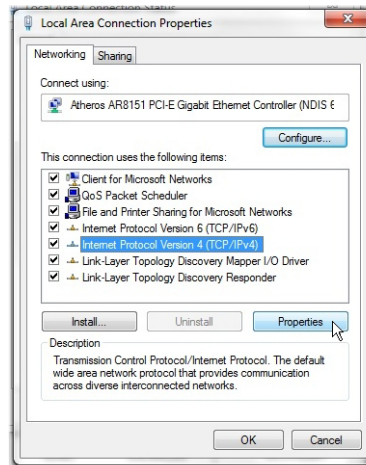

- The Internet Protocol (TCP/IP) Properties will be displayed, with the “General” tab showing. Select the “Alternate Configuration” tab.

Figure 5.20 — Internet Protocol Properties, General Settings Displayed

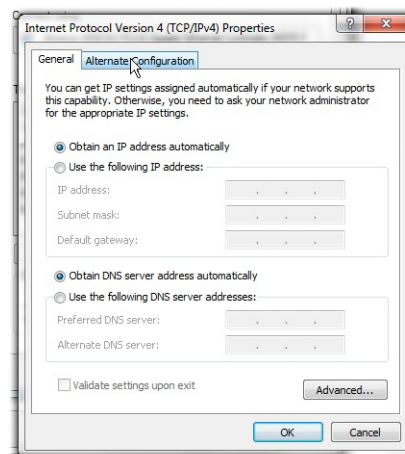

- In the Alternative Configuration Tab select “User configured” and enter the following details:

IP address: 192.168.2.1

Subnet Mask: 255.255.252.0 (Note this is NOT the auto setting)

Default Gateway: 192.168.2.254

Un-check the “Validate settings, if changed, upon exit” box.

Figure 5.21 — User Configured Alternate Configuration

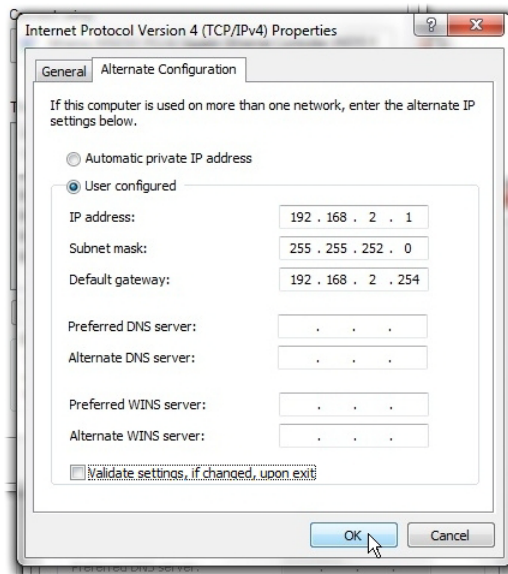

8. Select OK and the Properties box will close.  
Close the Local Area Connection Dialog box.



*Note: The Windows Network Diagnostics window may appear, simply press "Close the troubleshooter" as the network settings cannot be checked.*

### 5.3.4 IP Configuration “ConsoleConfig” Page

The IP Configuration Software is very similar to the SD Card configurator, the only difference being the method of uploading and downloading data to and from Consoles.

Figure 5.22 — IP “ConsoleConfig” Page

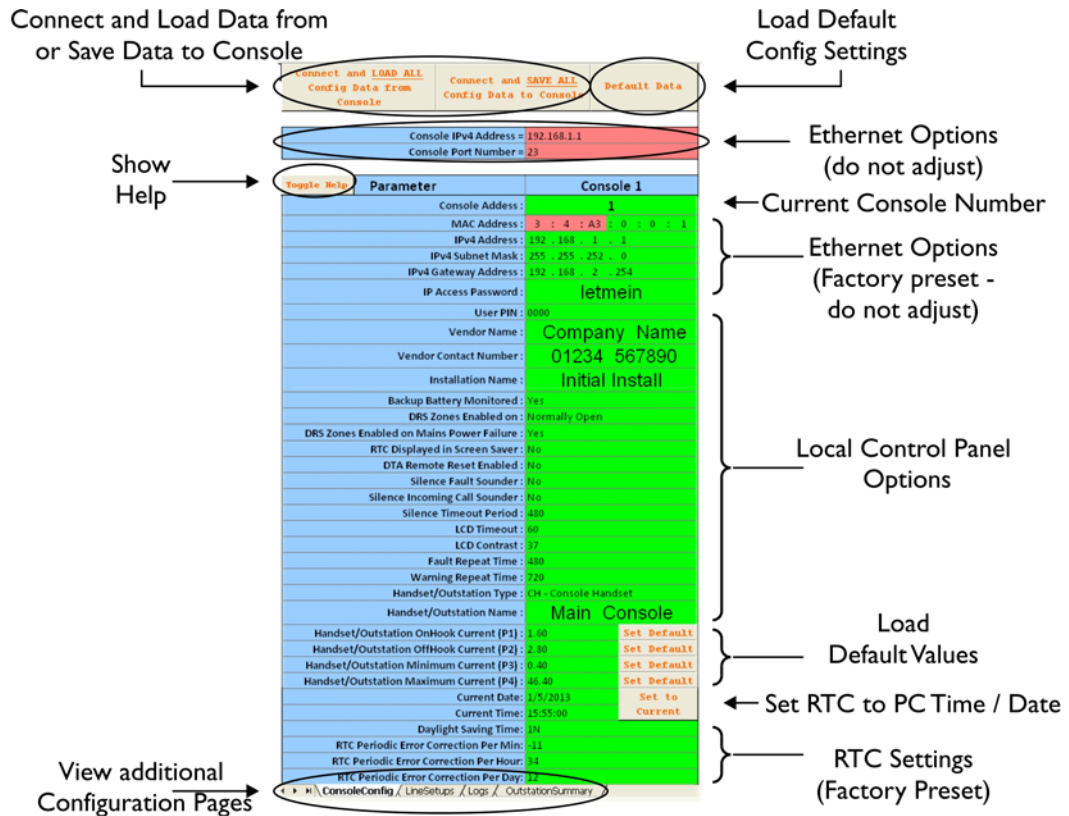

Title	Description
Connect and Load Data from / Save to Console	Buttons allow the operator to load a Copy of the Configuration from the Console, and to save the current Configuration to the Console
Show Help	Shows (or hides) the Help view
View Additional Config Pages	Switches to show additional Configuration Pages
Load Default Config Settings	Loads Default settings for ALL Console & Handset options
Current Console Number	Shows the Console Number for the Data being displayed: Select the required Console from the dropdown menu
Ethernet Options	Factory Preset (Do not adjust - sets the address for connecting via IP)
Local Console Options	Settings for the Local Console
Load Default Values	Load Default options for Handset Monitoring
Set to Current RTC	Load Real Time Clock settings from the PC
RTC Settings	Real Time Clock Settings (Factory Preset)

### 5.3.5 IP Configuration LineSetups Page

The IP LineSetups page is almost identical to the SD Card version as described in Section 5.2.2 and Section 5.2.3.

### 5.3.6 IP Configuration Logs Page

The IP Logs page is almost identical to the SD Card version as described in Section 5.2.7.

### 5.3.7 IP Configuration OutstationSummary Page

The IP OutstationSummary page is almost identical to the SD Card version as described in Section 5.2.8.

## 6 Operation

### 6.1 ACCEPT A SINGLE INCOMING CALL

When an Incoming Call is made the Console will Ring and the “Incoming Call” LED & the LCD Backlight Display will flash. The LCD Display will indicate the Outstation making the call.

*Figure 6.1 — LCD Display showing a Single Incoming Call*

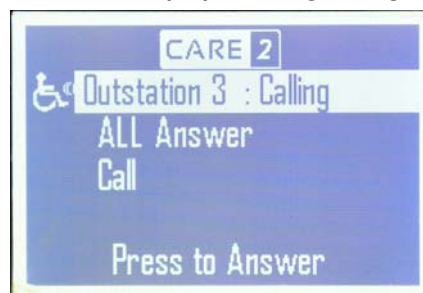

Open the Handset Door and pick up the handset.

Press the Encoder to accept the call and speak to the caller.

*Figure 6.2 — LCD Display showing Outstation 3 Busy (In Conversation)*

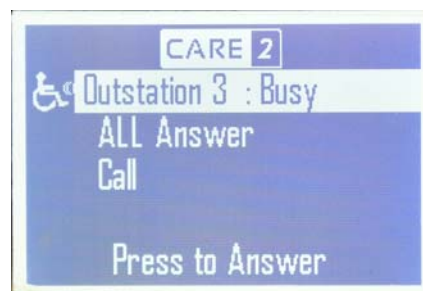

## 6.2 MULTIPLE INCOMING CALLS

When there are Multiple Incoming Calls the Console will Ring and the “Incoming Call” LED & the LCD Backlight Display will flash.

The LCD Display will indicate the Outstations making calls.

Figure 6.3 — LCD Display showing Multiple Incoming Calls

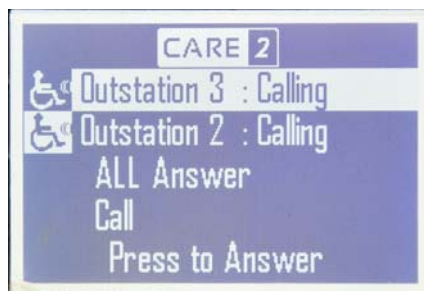

### 6.2.1 Selecting a Single Call

Open the Handset Door and pick up the handset.

Scroll up or down until the required Outstation is Highlighted.

Press the Encoder to answer the selected call.

The LCD Display will indicate the Answered Call, and also show the other caller is still calling as shown in Figure 6.4.

Figure 6.4 — LCD Display showing Answered and Waiting Calls

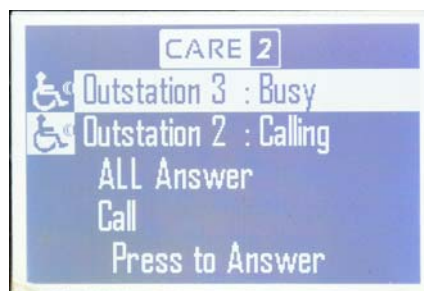

*NOTE: The Console Incoming Call LED & Sounder are silenced while a Call is in Progress.*

*New Calls are shown on the LCD Display but will not sound the Incoming Call Sounder.*

## 6.2.2 Selecting All Incoming Calls

Open the Handset Door and pick up the handset.

Scroll up until "All Answer" is highlighted as shown in Figure 6.5

Figure 6.5 — LCD Display showing All Answer with Multiple Calls

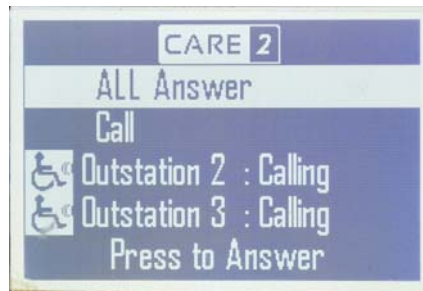

Press the encoder to answer All Incoming Calls and speak to All Outstations at the same time.

The LCD Display change to show multiple Busy Outstations.

Figure 6.6 — LCD Display showing Multiple Busy Remote Units.

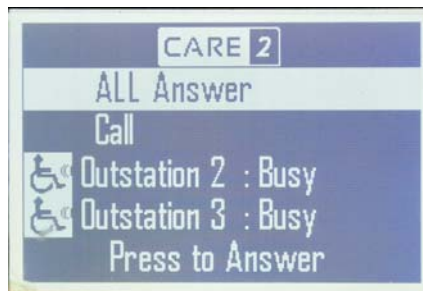

*NOTE: The "All Answer" feature creates a "Conference Call" between all active Outstations and the Console.*

## 6.3 PLACE CURRENT CALL ON “HOLD”

The Current Call can be placed on “Hold” by either:

Pressing the Encoder, or

Shutting the Handset Door.

Figure 6.7 — LCD Display showing Outstation 3 on Hold

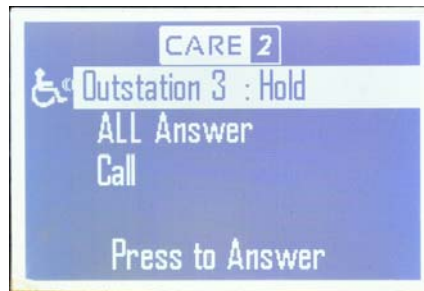

*NOTE: The Outstation will remain on Hold until the Console operator retrieves the Call.*

## 6.4 END A CALL

Press and hold the encoder while in conversation with the Outstation (e.g. while the LCD is indicating Busy).

After two seconds the LCD Display will indicate “Reset”, and will then return to the “Directory” menu.

Figure 6.8 — LCD Display showing Outstation 3 is being Reset

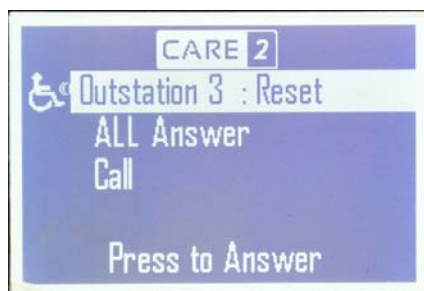

*NOTE: Calls can only be ended while "Busy" (in conversation). It is not possible to end calls that are on "Hold".*

Replace Handset and close and lock the Handset Door.

## 6.5 ANSWER A DISABLED TOILET ALARM

When an Incoming Call is made from a Disabled Toilet Alarm the Console will Ring and the “Incoming Call” LED & the LCD Backlight Display will flash.

The LCD Display will indicate the Outstation making the call.

Figure 6.9 — LCD Display showing a Disabled Toilet Alarm Incoming Call

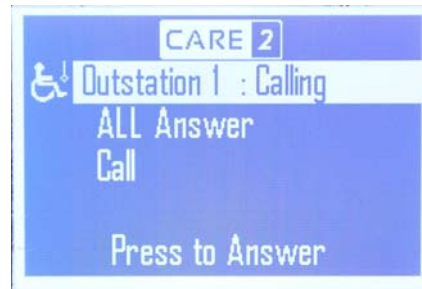

Open the Handset Door and press the Encoder to Accept the call.



*NOTE: It is not necessary to pick up the handset as it is not possible to talk to the Occupant.*

Figure 6.10 — LCD Display showing the DTA Call has been Accepted



At the Disabled Toilet, the Alarm will now change from a Continuous Tone to an Intermittent Tone to indicate it has been acknowledged at the Console.

By default an Accepted Call can only be reset by pressing the “Reset” button on the Local Reset Point within the Disabled Toilet.

However, it is also possible to reset Accepted DTA Calls at the Console using a “Long Encoder Press” if “DTA Resettable” is set to Active in the System Parameters menu.

Refer to Section 4.9.1 on page 55 for details.

## 6.6 MAKE A CALL

### 6.6.1 Call a Single Outstation

Open the Handset Door and pick up the Handset.

The LCD Display will show the “Directory” Menu with all the available Outstations.



---

*NOTE: Outstations that cannot accept calls will be shown in the Directory but will have "N/A" to indicate they cannot be called.  
Outstations that are currently "On Hold" will not be displayed.*

---

Scroll down until the required Outstation is highlighted.

Press the Encoder to call the required Outstation.

The LCD Display will indicate the Outstation is being Alerted.

Figure 6.11 — LCD Display showing Outstation 3 being Alerted

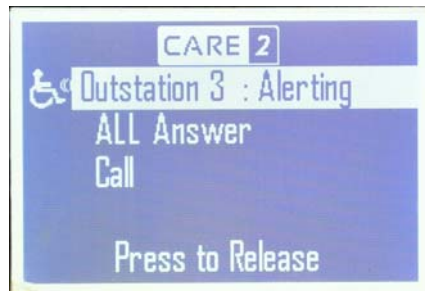

When the Outstation is answered the LCD display will indicate “Busy” (as shown in Figure 6.2) and the operator can speak to the Outstation.

To end the call refer to Section 6.4.

### 6.6.2 Call All Outstations

It is possible to Call All Outstations that are capable of receiving calls.

Open the Handset Door and pick up the Handset.

Scroll up until “All Call” is highlighted and press the encoder.

The LCD Display will show when each Outstation answers.

## 6.7 MAKE A CALL WHEN THE CURRENT CALL IS ON “HOLD”

After placing the current call on Hold (as shown in Figure 6.7) scroll down to the “CALL” option and press the encoder.

Follow the instructions detailed in Section 6.6.



## 7 Faults and Maintenance

### 7.1 ACCEPT A FAULT & SILENCE THE SOUNDER

If a fault is detected the relevant Fault LED on the Front Panel will illuminate (as shown in Figure 3.2 on page 32), the LCD Display will display the detected fault and the Fault Sounder will sound.

With the Handset Door closed and locked, press and hold the Encoder for three seconds to accept the Fault and silence the Fault Sounder.

### 7.2 RE-ANNOUNCING FAULTS

If a Fault is accepted (but not cleared) it will be re-announced after the time delay set in the “Fault Repeat” entry of the “System Parameters” menu (shown in Section 4.9.1 on page 55).

### 7.3 AUTOMATIC FAULT CLEARANCE

The Care2 Console will automatically clear accepted faults if they are remedied.

## 7.4 FAULTS ANNOUNCED WHILE “IN CALL”

If a fault is announced while the Console is “In Call” it will not be displayed on the LCD Display, however the buzzer will sound and the “Common Fault” LED will flash.

Press and hold the encoder to silence the buzzer (this does not accept the fault).

After the call is completed, replace the handset and close the Handset door.

Scroll down and select the “Maintenance” menu and navigate to the “Current Fault Status” page.

Any faults which have been announced but not accepted are shown indicated with a “\*\*”.

Scroll up or down to select faults showing the “\*\*” and press and hold the encoder to accept the faults.

## 7.5 VIEW FAULT HISTORY LOG

The Console will store the last 256 detected faults.

Close the Handset door.

Scroll down and select the “Maintenance” menu and navigate to the “Fault History Log” page.

Scroll up or down to for the required entry and press the encoder.

The Location, Type of Fault and the Date stamp will be displayed.

## 7.6 MAINTENANCE MENU STRUCTURE

Title	Description
Current Fault Status	View faults currently detected by the system, "***" shows faults announced but not accepted.
Fault History Logs	View the stored fault log
Unmount SD Card (PIN)	Enables safe removal of the SD Card
Vendor Contact Details	View the Vendor Contact Details
Clear Device Assigns (PIN)	Removes the Device Assignments from the internal modules (enables new / replacement modules to be fitted)
Force Sys Reset (PIN) <sup>1</sup>	Force a System Reset
Force Con Reset (PIN) <sup>2</sup>	Force a Console Reset
<sup>1</sup> : "System Reset" - Master Console only: Resets Master Console & All Network Cards <sup>2</sup> : "Console Reset" - Slave & NEP Panels: performs a reset of the Local Console only	

## 7.7 FAULT CODES & BASIC FAULTFINDING

The faults that may be displayed by a console are explained in the following sections:

### 7.7.1 “Battery Charger” - Local Console Fault

The battery charger has detected one of the following faults:  
Battery Open Circuit, Battery Low Voltage, or Charger fault.

### 7.7.2 “Power Supply” - Local Console Fault

The Mains Supply is not connected and the Console is operating on Batteries.

### 7.7.3 “System Restart xx” - Local Console Fault

There are five different System Restart faults:

- POR - Power On Reset - Console has restarted due to Power loss
- RI - Reset Instruction - Reset by code (Console or System Reset)
- TO - Time Out - Processor watchdog caused reset
- CM - Configuration Mistake - Internal Firmware Error
- BOR - Brown Out Restart - Internal Power Supply fault.

## 7.7.4 “Local Loop” - Local Console Fault

The Front Panel cannot detect the correct number of internal devices (C2CK4 Line Cards & C2CN Network Cards) to match the stored configuration.

## 7.7.5 “Lo Z” - Line Fault - Local Console Fault

The console has detected the Line Impedance has dropped below the minimum threshold (potentially a Short Circuit).

## 7.7.6 “Hi Z” - Line Fault - Local Console Fault

The console has detected the Line Impedance has increased beyond the maximum threshold (potentially an Open Circuit).

## 7.7.7 “NW Audio Loop” - Network Audio Fault

An Audio Fault has been detected on the network or the Audio Network Loop is no longer intact due to an open or short circuit.

## 7.7.8 “NW Loop” - Network Data Fault

A Data Fault has been detected on the network or the Data Network Loop is no longer intact due to an open or short circuit.

## 7.7.9 Deep Discharge (Low Voltage) Protection

The Internal Power Supply will disconnect the batteries if they discharge below 21V.

## 7.8 ROUTINE MAINTENANCE REQUIREMENTS

The Care2 System has been designed to meet the requirements of BS5839-9:2011, however the standard also provides recommendations for Maintenance and routine testing of the system that should be performed by the user.

The following sections of this Manual briefly describe the relevant requirements of BS5839-9:2011.

### 7.8.1 Appointment of a “Responsible Person”

A single, named person should be appointed to be responsible for all matters relating the Care2 System.

This person is responsible for the following activities:

- Ensuring the Testing and Servicing is performed according to the requirements described in Section 7.8.2.
- Ensuring that the required records of Testing & Servicing are retained,
- Ensuring all relevant staff are trained to use the system,
- Ensuring that records are updated to reflect any changes made to the system.

### 7.8.2 Routine Testing

#### 7.8.2.1 Daily Check - Fault Indicators

If the Care2 Console is located in a position where the audible fault warning could be unnoticed for more than 24 hours, a special check should be performed each day to confirm that either the “System Healthy” LED is illuminated, or any faults that are indicated are receiving necessary attention.



*NOTE: This Check only needs to be performed if the Warning Buzzer may go unheard for 24 hours.*

*This inspection does not need to be recorded.*

---

### 7.8.2.2 Weekly Functional Test

Each week, a functional test of a Remote Unit should be performed to ensure it can make and receive clear and intelligible calls to the relevant Console(s).

A different Remote Unit should be used each week, so that all units will get tested in rotation.



*NOTE: The result of this weekly test and the identity of the Remote Unit used should be recorded.*

---

### 7.8.2.3 Six Monthly Inspection by a “Competent Person”

The Standard recommends that every six months the System should be thoroughly inspected to ensure continued reliability.

The “Competent Person” must have suitable knowledge and equipment to be able to check the system.

Baldwin Boxall can perform these Inspections under a Service Agreement.



*NOTE: The result of this inspection and any outstanding defects will be reported to the "Responsible Person". These should be recorded.*

---