

# RB C60

## Datasheet

Rev. 5 • Update 07/2020



RB C60\_600

RB C60\_800

The **RB C60** automatic rising obstacles were designed to protect and control access to sensitive sites.

This kind of equipment can be used on any site to create a retractable obstacle to control the vehicles traffic without restricting pedestrian access.

In urban environments, the RB C60 obstacles offer the advantage of being completely invisible when lowered.

They are also well-suited for controlling vehicles access to pedestrian areas.

The retractable obstacles are available with two cylinder heights from floor level, with two different code references:

- **RB C60\_600** : 600mm
- **RB C60\_800** : 800mm

## GENERAL DESCRIPTION

1. Painted (RAL 7016 - Anthracite grey) steel mobile obstacle (FE 370) diameter around 275 mm, 10 mm thick. The obstacle is available in three finishing options \*: Painted steel, painted stainless steel or brushed stainless steel.
2. Anti-skid cast aluminium crown (RAL 9006 - White aluminium). The upper crown is also available with LED indicator lights (on the perimeter of the crown).\*
3. Double reflective strip on the upper part of the obstacle, 55 mm height.
4. Thick steel supporting structure.
5. Cast aluminium cover plate and link frame between the obstacle and the road surface (mounted onto the embedded casing).
6. Galvanized sheet steel embedded casing.
7. Mobile obstacle is held vertically and reinforced by means of a thick steel collar connected to the supporting structure and a built-in nylon bush and sliding along the central jack.
8. Synthetic joint.
9. Double-acting central hydraulic jack for rising and lowering the obstacle. In order to limit damage caused by moderate impacts, the obstacle is not fixed to the jack.
10. Hydraulic unit mounted on the supporting structure. Lower hydraulic pressure during rising of the obstacle to allow a movement reversal if an obstacle > 40 kg is detected. Full pressure is applied during the final 10 cm of the rising cycle and in the up position.
11. The hydraulic pump is automatically switched in up position by receiving a pressure switch signal.
12. Steel/rubber bearings support the obstacle in low position, allowing it to withstand the passage of heavy vehicles.
13. Inductive sensor delivers to the logic control board a low position status information.
14. A remote microprocessor control board is located in a cubicle separated from the obstacle (10 m of electric cable provided). The features include dipswitches to modify the settings, LED display for obstacle status information and inputs/outputs level.

\* Product configuration to be specified when ordering.



## SURFACE PROTECTION

### Treatment B:

- Sandblasting (SA 2,5)
- Epoxy powder primer (80 µm)
- Polyester powder finishing paint (80 µm)

## STANDARD TECHNICAL CHARACTERISTICS

Breakout resistance certification																															
Certification	PAS68:2013 V/3500(N1)/48/90 IWA 14-1:2013 V/3500(N1)/48/90 ASTM C60																														
Impact resistance (Vehicles type)	1.5 T at 80 km/h 3.5 T at 48 km/h																														
Impact resistance	400.000 joules																														
Impact resistance (without deformation)	40.000 joules																														
Power supply:	Single phase, 230 V - 50 Hz																														
 do not connect to a floating network or to high impedance earthed industrial distribution network																															
Max. power consumption:	400 W.																														
	<table border="1"> <thead> <tr> <th></th> <th>RB C60_600</th> <th>RB C60_800</th> </tr> </thead> <tbody> <tr> <td>Obstacle height:</td> <td>600 mm</td> <td>800 mm</td> </tr> <tr> <td>Rising speed:</td> <td>4 sec</td> <td>5,5 sec</td> </tr> <tr> <td>Lowering speed:</td> <td>2.5 sec</td> <td>3.5 sec</td> </tr> <tr> <td>Weight:</td> <td>± 210 kg</td> <td>± 219 kg</td> </tr> <tr> <td>Operating temperature:</td> <td colspan="2">-10 to +70°C.</td> </tr> <tr> <td>Frequency of use:</td> <td colspan="2">2000 operations per day.</td> </tr> <tr> <td>MCBF: (Mean cycles between failures)</td> <td colspan="2">3.000.000 cycles, respecting the recommended maintenance procedure</td> </tr> <tr> <td>Protection index:</td> <td colspan="2">IP 67 for hydraulic components</td> </tr> <tr> <td colspan="3">Conform to European standards</td> </tr> </tbody> </table>		RB C60_600	RB C60_800	Obstacle height:	600 mm	800 mm	Rising speed:	4 sec	5,5 sec	Lowering speed:	2.5 sec	3.5 sec	Weight:	± 210 kg	± 219 kg	Operating temperature:	-10 to +70°C.		Frequency of use:	2000 operations per day.		MCBF: (Mean cycles between failures)	3.000.000 cycles, respecting the recommended maintenance procedure		Protection index:	IP 67 for hydraulic components		Conform to European standards		
	RB C60_600	RB C60_800																													
Obstacle height:	600 mm	800 mm																													
Rising speed:	4 sec	5,5 sec																													
Lowering speed:	2.5 sec	3.5 sec																													
Weight:	± 210 kg	± 219 kg																													
Operating temperature:	-10 to +70°C.																														
Frequency of use:	2000 operations per day.																														
MCBF: (Mean cycles between failures)	3.000.000 cycles, respecting the recommended maintenance procedure																														
Protection index:	IP 67 for hydraulic components																														
Conform to European standards																															

## WORK TO BE PROVIDED BY THE CUSTOMER

- Embed casing to be fixed in a concrete foundation. (Refer to installation drawing)
- Drainage or connection to main drainage (if necessary).
- 230V single phase power supply.
- Connect electrical cables between the bollard and the control unit and between the control unit and the main power supply.

## OPTIONS

1. Casing in aluzinc or in stainless steel AISI 304.
2. Suspended casing kit option.
3. Metal trap for closing counterframe with screws.
4. Indicator lights (LEDs on the perimeter of the crown) – flashing with or without warning given a few seconds prior to obstacle operation.
5. Intermittent audible signal with or without warning given prior to obstacle operation.
6. Painting with other RAL color.
7. Anti-corrosion treatment for cylinder or/and frame.
8. Anticorrosive treatment M: 
  - Sandblasting SA 2.5
  - Epoxy powder paint of ± 80 µm thick;
  - Two-component Epoxy paint of ± 180 µm thick;
  - Two-component polyurethane topcoat of ± 60 µm thick.
9. Biodegradable oil for the hydraulic pipes.
10. Additional electrical connection line (connecting RB to the control unit). Max. 80 meters.
11. IP68 sealed fast connectors for cables interconnections.
12. Heating resistance for operation at low temperatures down to -40° C or in case of use in areas highly exposed to snow or prolonged freezing conditions.
13. Mobile cylinder finishing: normal steel or AISI 304 stainless steel with ribs on surface or AISI 316 brushed stainless steel.
14. Kit of anti-tampering screws of the crown - removable key.
15. E.F.O. (circuit for emergency rising at high speed (around 1.5 s)).
16. Automatic lowering cycle in case of power failure.
17. UPS (power supply in case of power failure).
18. Feeder/Accumulator group on control panel for emergency lowering in case of power failure.
19. Manual up/down operation in case of power failure.
20. Kit UP/DOWN position auxiliary contacts (dry contact).
21. Alarm kit (1 status contact high position RB - 1 status contact RB cover plate).
22. Floor metallic column for control unit.
23. Retractable structure with double pit for control unit.
24. Heating device for control unit.
25. Traffic light, LED version, Red/Green (Ø 100 mm).
26. Galvanised post for traffic light.
27. Inductive detector for safety inductive loop.
28. Pressure gauge to show pressure in the hydraulic pump.
29. Inductive loop for vehicle detection.
30. Photo-electric cell (T/R or Reflex).
31. Radio Transmitter/Receiver.
32. Push button box.

 Mandatory for an installation less than 2 km from a seaside or for intensive sandblasted pavement (3 months/year).

## STANDARD DIMENSIONS (mm) FOR RB C60\_600

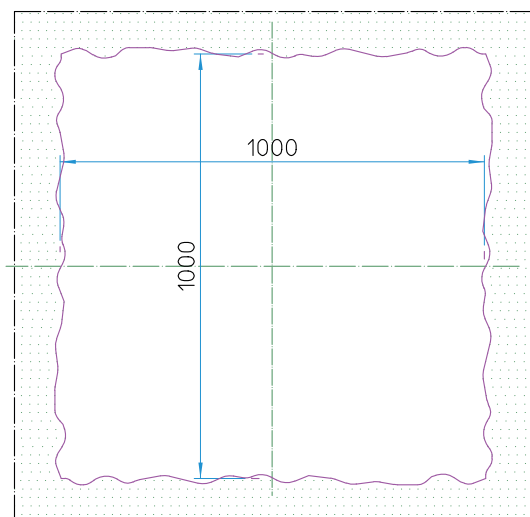
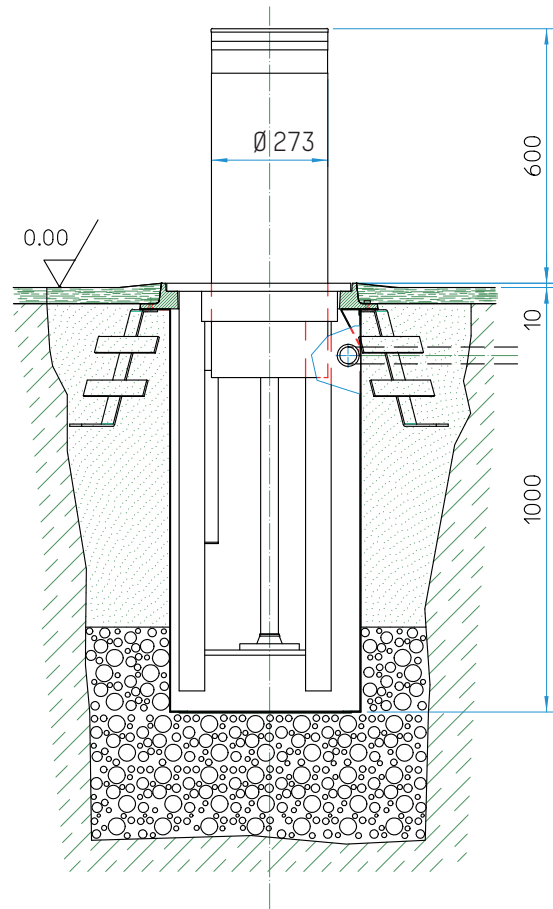
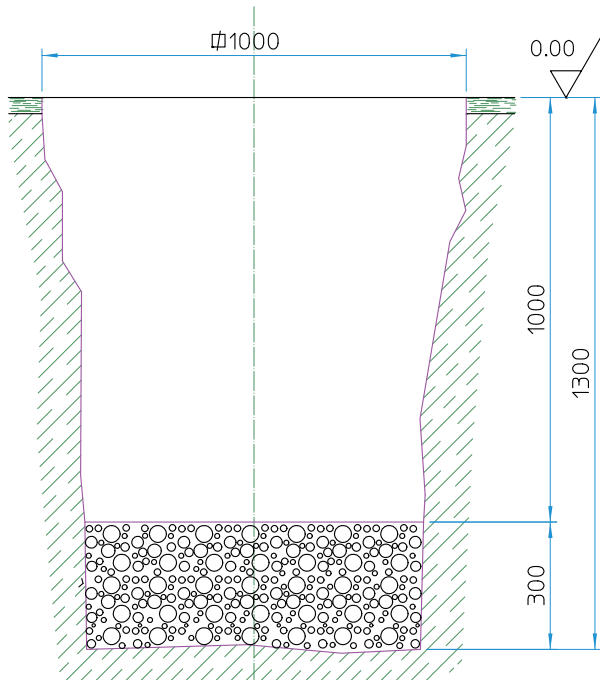

TRAFFIC WAY  
↕

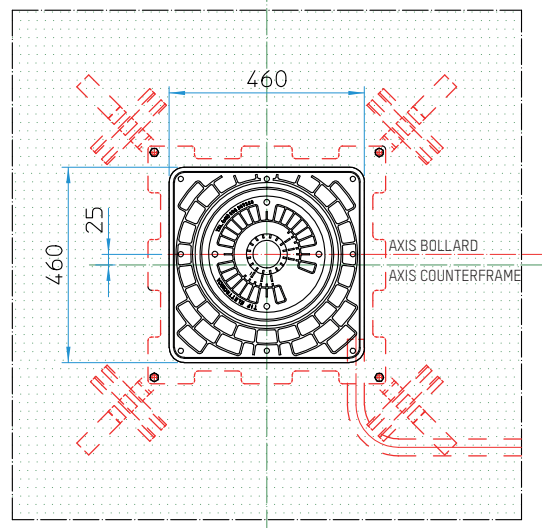

## STANDARD DIMENSIONS (mm) FOR RB C60\_800

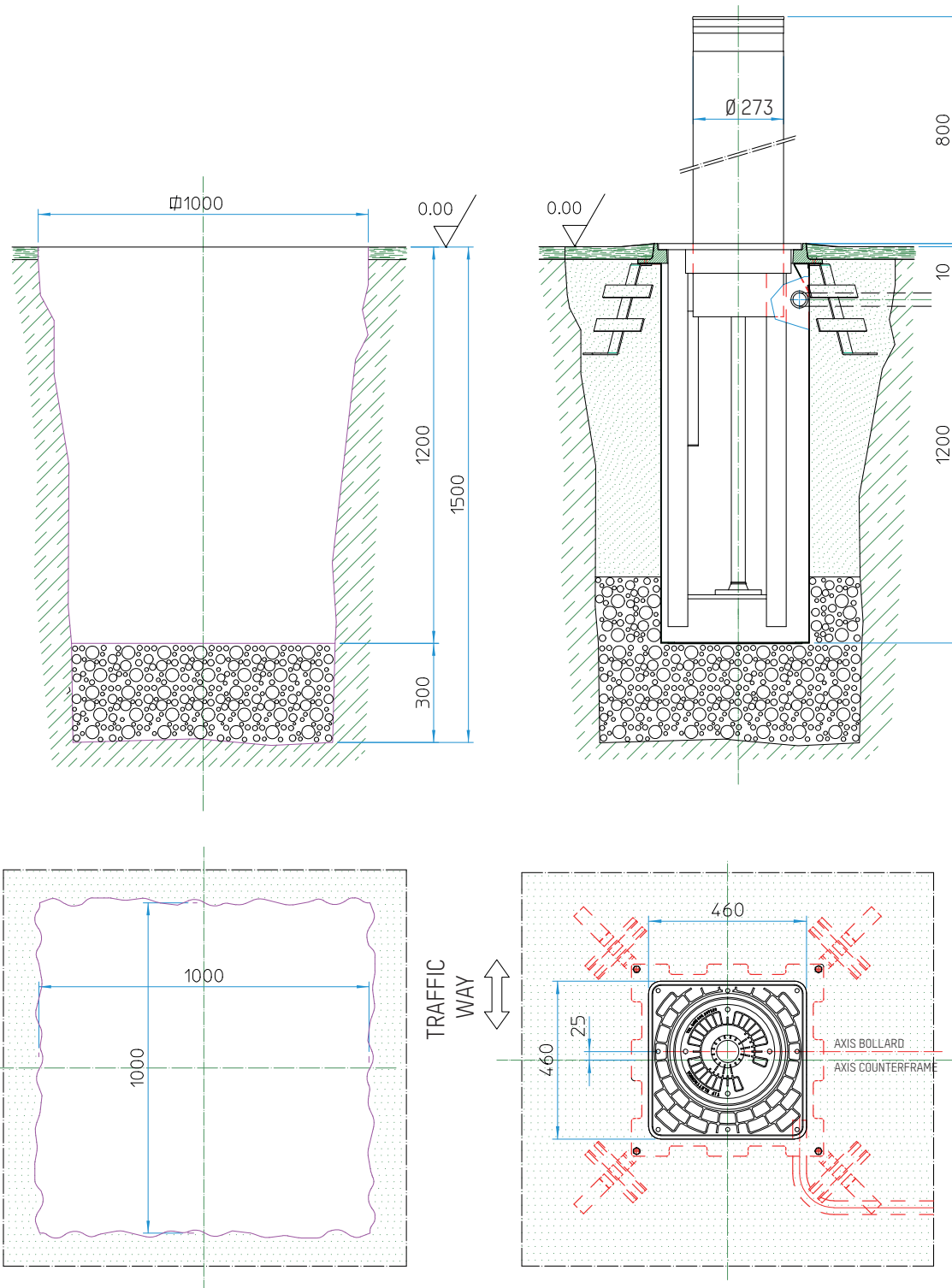

### Headquarters

Avenue Mercator, 5  
1300 Wavre - Belgium



helpdesk.as@automatic-systems.com



+32.(0)10.23.02.11



www.automatic-systems.com

