

Aluminium Soffit

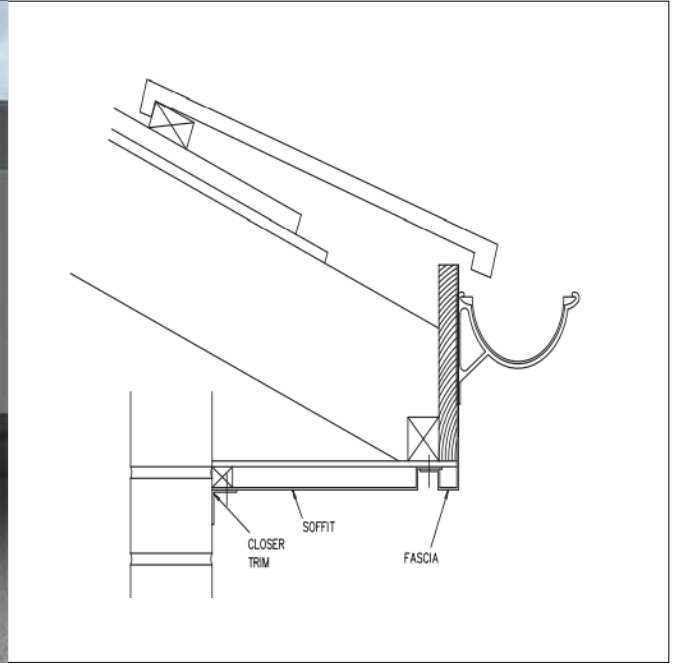

Product Description

Aluminium Soffits have become the widely preferred option due to the sleek appearance and the range of options available. Lightweight, corrosion resistant, low maintenance and aesthetically pleasing characteristics.

Properties

Made from 1050AH14 grade aluminium sheet to BS2997 (EN612) with thickness determined by the overall girth required, up to 450mm -2mm sheet, 450mm + - 3mm sheet

100% recyclable, lightweight and strong

Various soffit profiles including flat, z plank and radius soffits are available.

Available Mill Finished (uncoated) or coated on ARP's in-house Polyester Powder Coating line to clients choice of RAL or BS standard colours.

Installation

Joints to be by internal union sealed by application of Arbosil 1096 Low Modulus Silicone Sealant & fastened by 5mm x 25mm stainless steel screws in accordance with the manufacturer's specification & guidelines. Direct fixed at 600mm centres with additional fixings at fittings as required.

Functional Life Expectancy:

ARP qualifies that when installed correctly and maintained in accordance with its product guidelines and O&M procedure, its products are designed to give a minimum effective functional life expectancy of 30 years.

Specification Information

Clause: R10/311 Aluminium Soffits

Product: Trueline Aluminium Soffits

Manufacturer: ARP Ltd
Unit 2 Vitruvius Way
Meridian Business Park
Braunstone, Leicester
LE19 1WA

Handling & Storage:

Fascia, Soffits and other bespoke fabrications, particularly with a polyester powder coat finish should be handled with care and should preferably be stored under cover on racks to prevent scratching. All lengths are supplied in protective polythene wrapping and components are suitably packed in boxes. If painted products are to be stored outside, cover with a tarpaulin to guard against water ingress into the protective polythene. Mill finish items should be stored undercover to avoid uneven oxidation prior to being fitted.

Maintenance:

In order to maintain proper working order, fascia and soffits should be inspected periodically. Check all fixings are secure and take any remedial action to rectify if necessary. To maximise the life of the decorative paint finishes, all parts should be washed down with clean water at least every 12 months and any damage repaired. In marine/ industrial environments, this period may need to be shortened to 6 months.

Further Information

Please visit www.arp-ltd.com or contact the ARP team of 0116 289 4400 for any other information