

### TECHNICAL PRODUCT GUIDE 2021

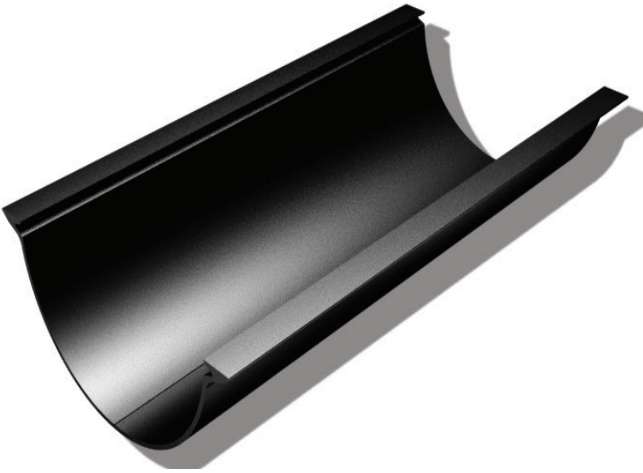

# SENTINEL

## Extruded Aluminium Gutters



Beaded Half Round



Deepflow Half Round



Vintage Ogee



Modern Ogee

	100mm	114mm	125mm	150mm	200mm
<b>Beaded Half Round Snap-fit</b>		✓	✓	✓	
<b>Deepflow Half Round</b>			✓		
<b>Vintage Ogee Snap-fit</b>	✓		✓	✓	
<b>Modern Ogee</b>					✓

Extruded aluminium gutters are a fantastic option for new build and refurbishment applications due to their smooth lines, clean appearance and robust properties.

With a choice of profile options and providing 'fit and forget' peace of mind, extruded systems have become a real sustainable choice to both homeowner and specifier.

- Made from aluminium alloy 6063, T6 to BS1474:1972.
- 100% recyclable.
- Lightweight and strong.
- Durable and non-corrosive.
- Variety of profiles available.
- Radius and special fittings can be provided.
- Mill finish or powder coated to your choice of RAL/BS colour.
- Full fitting instructions included with every delivery.
- Expected to last in excess of 60 years, with minimal maintenance.





System Overview

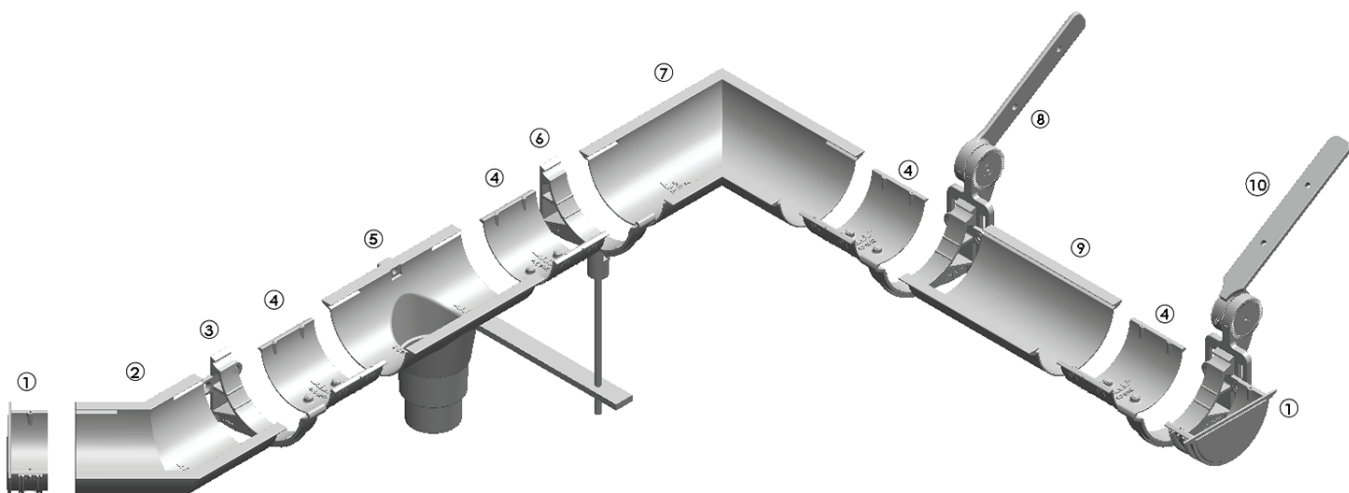

Number	Item	Number	Item
1	Universal Stopend	6	Rise and Fall Bracket
2	135° Universal Angle	7	90° Universal Angle
3	Fascia Bracket	8	Side Fix Rafter Bracket
4	Union Connector	9	Gutter Length
5	Running Outlet	10	Top Fix Rafter Bracket

**Gutter Lengths**

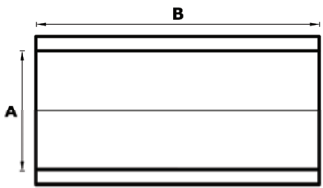

GUTTER SIZE A	B	DEPTH	PRODUCT CODE
114	3000	59	4.5BHRG3
114	2500	59	4.5BHRG2.5
114	2000	59	4.5BHRG2
114	1000	59	4.5BHRG1
114	500	59	4.5BHRG0.5
125	3000	65	5BHRG3
125	2500	65	5BHRG2.5
125	2000	65	5BHRG2
125	1000	65	5BHRG1
125	500	65	5BHRG0.5
150	3000	79	6BHRG3
150	2500	79	6BHRG2.5
150	2000	79	6BHRG2
150	1000	79	6BHRG1
150	500	79	6BHRG0.5

Faceted Radius Gutters can be made to a template. 1m max template required, for more information contact our Technical Team.

**90° Universal Angle**

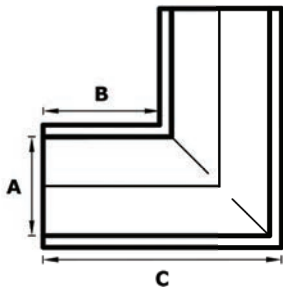

GUTTER SIZE A	B	C	PRODUCT CODE
114	75	219	4.5BHRA90
125	75	232	5BHRA90
150	75	258	6BHRA90

Non standard angles available on request.

**135° Universal Angle**

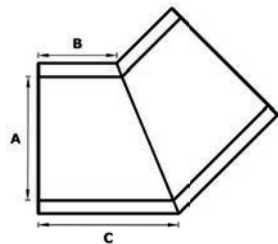

GUTTER SIZE A	B	C	PRODUCT CODE
114	75	135	4.5BHRA135
125	75	140	5BHRA135
150	75	151	6BHRA135

Non standard angles available on request.

All dimensions shown in mm unless otherwise stated.

Running Outlet

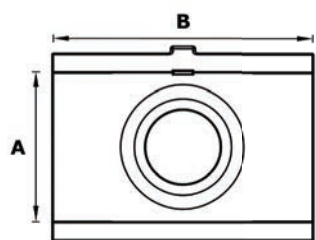

Standard



Tapered



GUTTER SIZE A	OUTLET SIZE	OUTLET TYPE	B	PRODUCT CODE
114	Ø63	Tapered	200	4.5BHRO2R
114	Ø76	Tapered	200	4.5BHRO3R
114	63 sq	Standard	200	4.5BHRO2S
114	76 sq	Standard	200	4.5BHRO3S
114	101 x 76	Standard	200	4.5BHRO43
125	Ø63	Tapered	220	5BHRO2R
125	Ø76	Tapered	220	5BHRO3R
125	Ø101	Standard	220	5BHRO4R
125	63 sq	Standard	220	5BHRO2S
125	76 sq	Standard	220	5BHRO3S
125	101 x 76	Standard	220	5BHRO43
125	101 Sq	Standard	220	5BHRO4S
150	Ø63	Standard	260	6BHRO2R
150	Ø76	Standard	260	6BHRO3R
150	Ø101	Standard	260	6BHRO4R
150	63 sq	Standard	260	6BHRO2S
150	76 sq	Standard	260	6BHRO3S
150	101 x 76	Standard	260	6BHRO43
150	101 Sq	Standard	260	6BHRO4S

Universal Internal Stopend



GUTTER SIZE A	B	PRODUCT CODE
114	40	4.5BHRSE
125	40	5BHRSE
150	40	6BHRSE

Union Connector

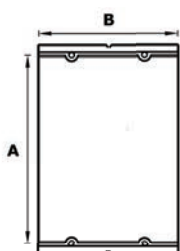

GUTTER SIZE A	B	PRODUCT CODE
114	80	4.5BHRUC
125	80	5BHRUC
150	80	6BHRUC

All dimensions shown in mm unless otherwise stated.

**Fascia Bracket**

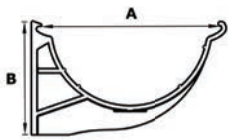

GUTTER SIZE A	B	PRODUCT CODE
114	90	4.5BHRBF
125	100	5BHRBF
150	110	6BHRBF

Width of fascia bracket = 25mm

**Top Fix Rafter Bracket**

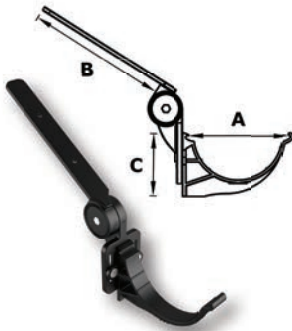

GUTTER SIZE A	B	C	PRODUCT CODE
114	195	90	4.5BHRBRT
125	195	100	5BHRBRT
150	195	110	6BHRBRT

Brackets can be set to required roof pitch but manual adjustment can be made on side if required.

**Side Fix Rafter Bracket**

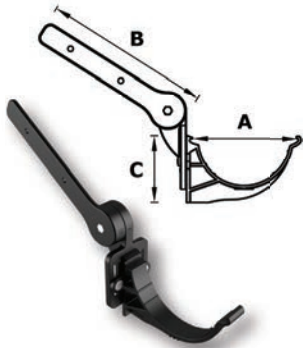

GUTTER SIZE A	B	C	PRODUCT CODE
114	225	90	4.5BHRBRS
125	225	100	5BHRBRS
150	225	110	6BHRBRS

Brackets can be set to required roof pitch but manual adjustment can be made on side if required.

**Rise and Fall Bracket**

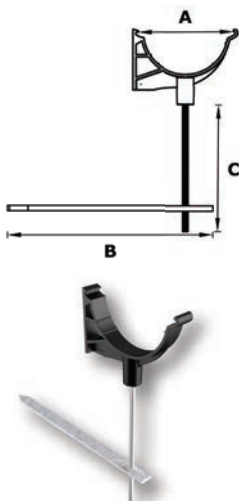

GUTTER SIZE A	B	C	PRODUCT CODE
114	330	190	4.5BHRBRF
125	330	190	5BHRBRF
150	330	190	6BHRBRF

All dimensions shown in mm unless otherwise stated.



System Overview

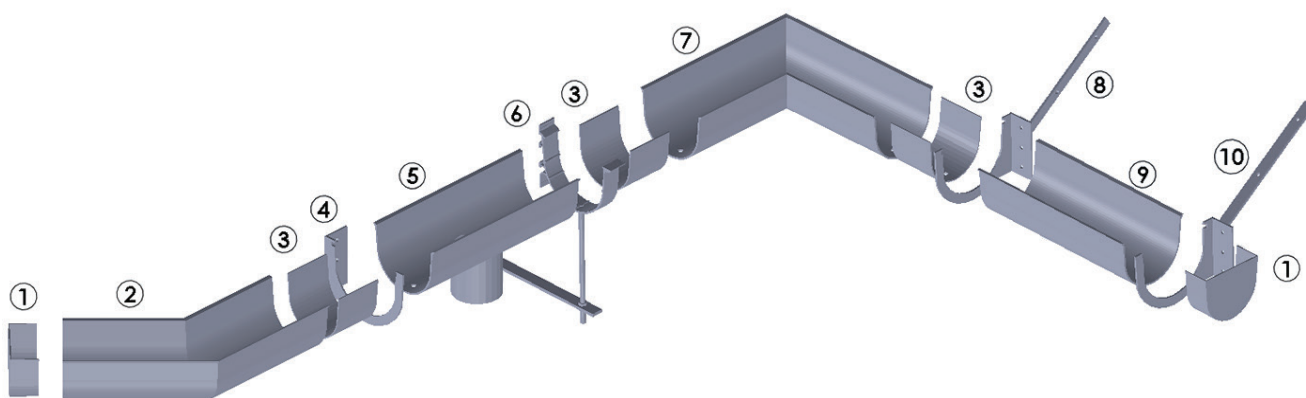

Number	Item	Number	Item
1	Universal Stopend	6	Rise and Fall Bracket
2	135° Universal Angle	7	90° Universal Angle
3	Union Connector	8	Side Fix Rafter Bracket
4	Fascia Bracket	9	Gutter Length
5	Running Outlet	10	Top Fix Rafter Bracket

**Gutter Lengths**

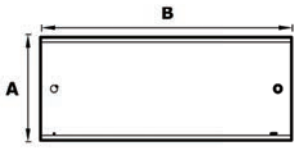

GUTTER SIZE A	B	DEPTH	PRODUCT CODE
125	3000	100	54DHRG3
125	2500	100	54DHRG2.5
125	2000	100	54DHRG2
125	1000	100	54DHRG1
125	500	100	54DHRG0.5

Faceted radius gutter available on request.

**90° Universal Angle**

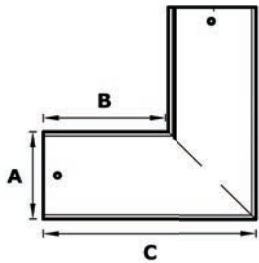

GUTTER SIZE A	B	C	PRODUCT CODE
125	150	275	54DHRA90

Non standard angles available on request.

**135° Universal Angle**

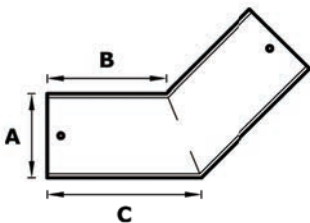

GUTTER SIZE A	B	C	PRODUCT CODE
125	150	203	54DHRA135

Non standard angles available on request.

**Running Outlet**

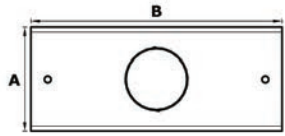

GUTTER SIZE A	OUTLET SIZE	B	PRODUCT CODE
125	Ø63	300	54DHRO2R
125	Ø76	300	54DHRO3R
125	Ø101	300	54DHRO4R
125	63 sq	300	54DHRO2S
125	76 sq	300	54DHRO3S
125	101 x 76	300	54DHRO43
125	101 sq	300	54DHRO4S

**Universal Stopend**



GUTTER SIZE A	B	PRODUCT CODE
125	40	54DHRSE

**Union Connector**

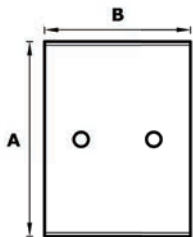

GUTTER SIZE A	B	PRODUCT CODE
125	80	54DHRUC

All dimensions shown in mm unless otherwise stated.

Fascia Bracket

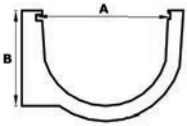

GUTTER SIZE A	B	PRODUCT CODE
125	100	54DHRBF

Top Fix Rafter Bracket

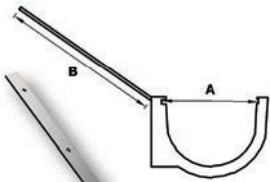

GUTTER SIZE A	B	PRODUCT CODE
125	230	54DHRBRT

Brackets can be set to required roof pitch but manual adjustment can be made on side if required.

Side Fix Rafter Bracket

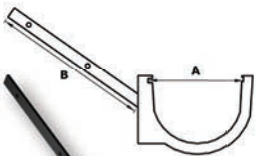

GUTTER SIZE A	B	PRODUCT CODE
125	230	54DHRBRS

Brackets can be set to required roof pitch but manual adjustment can be made on side if required.

Rise and Fall Bracket

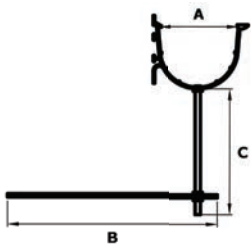

GUTTER SIZE A	B	C	PRODUCT CODE
125	230	200	54DHRBRF

All dimensions shown in mm unless otherwise stated.



System Overview

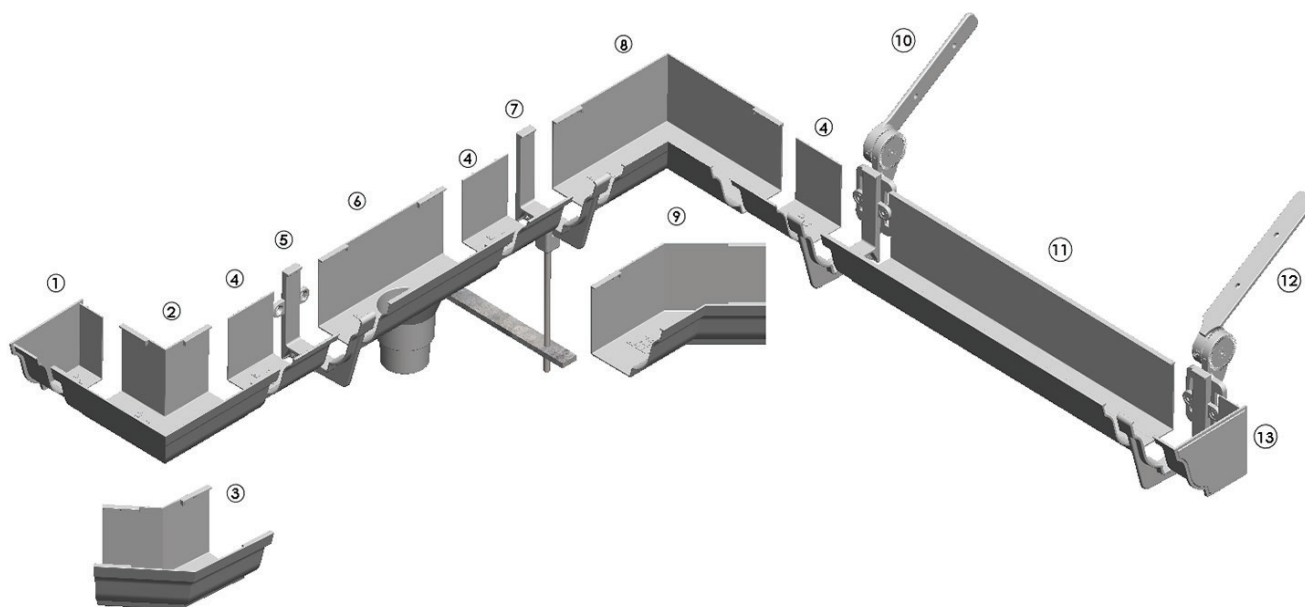

Number	Item	number	Item
1	Left Hand Stopend	8	90° Internal Angle
2	90° External Angle	9	135° Internal Angle
3	135° External Angle	10	Side Fix Rafter Bracket
4	Union Connector	11	Gutter Length
5	Fascia Bracket	12	Top Fix Rafter Bracket
6	Running Outlet	13	Right Hand Stopend
7	Rise and Fall Bracket		

**Gutter Lengths**

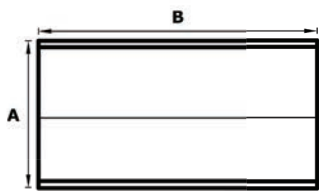

GUTTER SIZE A (W X D)	B	PRODUCT CODE
100 x 75	3000	43VOG3
100 x 75	2500	43VOG2.5
100 x 75	2000	43VOG2
100 x 75	1000	43VOG1
100 x 75	500	43VOG0.5
125 x 100	3000	54VOG3
125 x 100	2500	54VOG2.5
125 x 100	2000	54VOG2
125 x 100	1000	54VOG1
125 x 100	500	54VOG0.5
150 x 100	3000	64VOG3
150 x 100	2500	64VOG2.5
150 x 100	2000	64VOG2
150 x 100	1000	64VOG1
150 x 100	500	64VOG0.5

Faceted radius gutter available on request.

**90° External Angle**

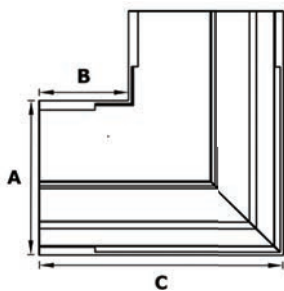

GUTTER SIZE A (W X D)	B	C	PRODUCT CODE
100 x 75	75	180	43VOAX90
125 x 100	75	205	54VOAX90
150 x 100	75	234	64VOAX90

Non standard angles available on request.

**90° Internal Angle**

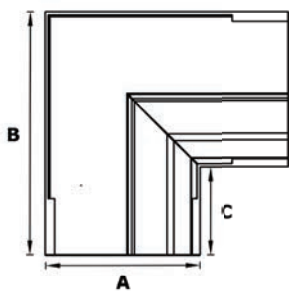

GUTTER SIZE A (W X D)	B	C	PRODUCT CODE
100 x 75	180	75	43VOAI90
125 x 100	205	75	54VOAI90
150 x 100	234	75	64VOAI90

Non standard angles available on request.

All dimensions shown in mm unless otherwise stated.

135° External Angle

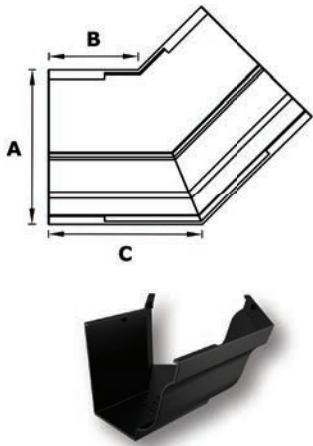

GUTTER SIZE A (W X D)	B	C	PRODUCT CODE
100 x 75	75	118	43VOAX135
125 x 100	75	129	54VOAX135
150 x 100	75	141	64VOAX135

Non standard angles available on request.

135° Internal Angle

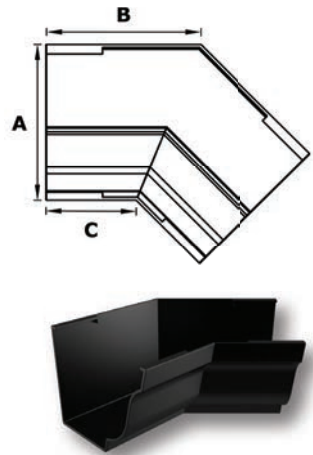

GUTTER SIZE A (W X D)	B	C	PRODUCT CODE
100 x 75	75	118	43VOAI135
125 x 100	75	129	54VOAI135
150 x 100	75	141	64VOAI135

Non standard angles available on request.

Stopends



GUTTER SIZE A (W X D)	B	PRODUCT CODE LH	PRODUCT CODE RH
100 x 75	40	43VOSEL	43VOSER
125 x 100	40	54VOSEL	54VOSER
150 x 100	40	64VOSEL	64VOSER

All dimensions shown in mm unless otherwise stated.

**Running Outlet**

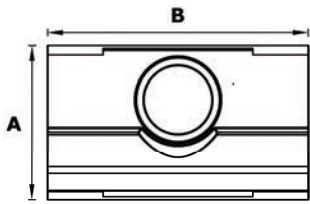

Standard



Tapered



GUTTER SIZE A (W X D)	OUTLET SIZE	OUTLET TYPE	B	PRODUCT CODE
100 x 75	Ø63	Standard	200	43VOO2R
100 x 75	Ø76	Standard	200	43VOO3R
100 x 75	63 sq	Standard	200	43VOO2S
100 x 75	76 sq	Standard	200	43VOO3S
100 x 75	101 x 76	Standard	200	43VOO43
125 x 100	Ø63	Tapered	220	54VOO2R
125 x 100	Ø76	Tapered	220	54VOO3R
125 x 100	Ø101	Standard	220	54VOO4R
125 x 100	63 sq	Standard	220	54VOO2S
125 x 100	76 sq	Standard	220	54VOO3S
125 x 100	101 x 76	Standard	220	54VOO43
125 x 100	101 Sq	Standard	220	54VOO4S
150 x 100	Ø63	Standard	220	64VOO2R
150 x 100	Ø76	Tapered	220	64VOO3R
150 x 100	Ø101	Tapered	220	64VOO4R
150 x 100	63 sq	Standard	220	64VOO2S
150 x 100	76 sq	Standard	220	64VOO3S
150 x 100	101 x 76	Standard	220	64VOO43
150 x 100	101 Sq	Standard	220	64VOO4S

**Union Connector**

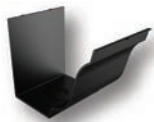
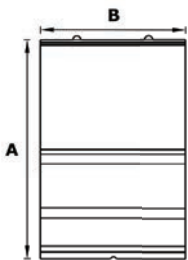

GUTTER SIZE A (W X D)	B	PRODUCT CODE
100 x 75	80	43VOUC
125 x 100	80	54VOUC
150 x 100	80	64VOUC

## Fascia Bracket

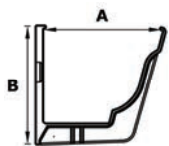

GUTTER SIZE A (W X D)	B	PRODUCT CODE
100 x 75	108	43VOBF
125 x 100	132	54VOBF
150 x 100	130	64VOBF

Width of fascia bracket = 25 mm

## Top Fix Rafter Bracket

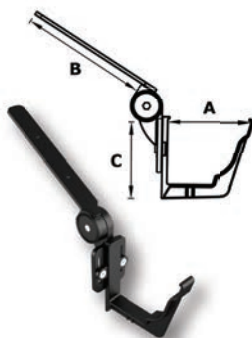

GUTTER SIZE A (W X D)	B	PRODUCT CODE
100 x 75	195	43VOBRT
125 x 100	195	54VOBRT
150 x 100	195	64VOBRT

Brackets can be set to required roof pitch but manual adjustment can be made on side if required.

## Side Fix Rafter Bracket

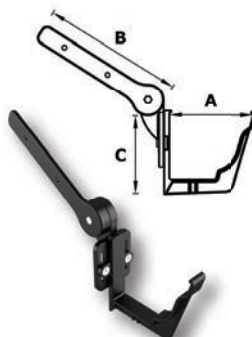

GUTTER SIZE A (W X D)	B	PRODUCT CODE
100 x 75	225	43VOBRS
125 x 100	225	54VOBRS
150 x 100	225	64VOBRS

Brackets can be set to required roof pitch but manual adjustment can be made on side if required.

## Rise and Fall Bracket

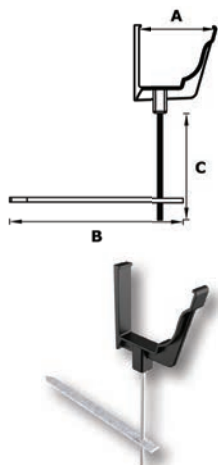

GUTTER SIZE A (W X D)	B	C	PRODUCT CODE
100 x 75	330	190	43VOBRF
125 x 100	330	190	54VOBRF
150 x 100	330	190	64VOBRF

All dimensions shown in mm unless otherwise stated.



**System Overview**

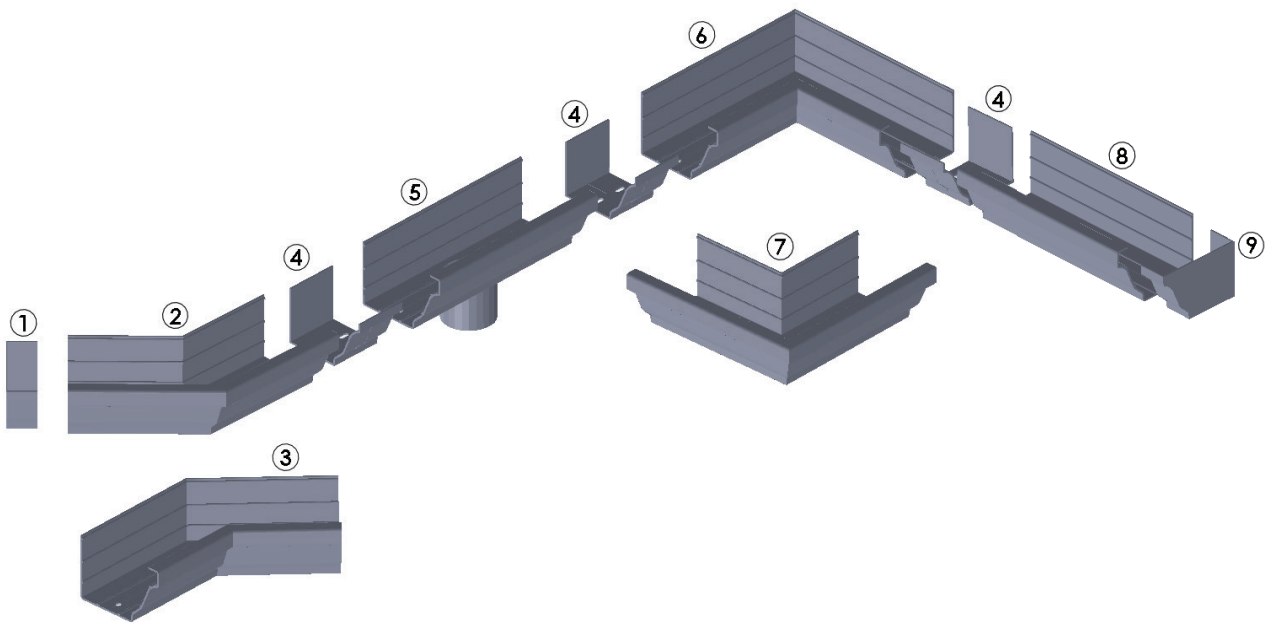

Number	Item	Number	Item
1	Left Hand Stopped	6	90° Internal Angle
2	135° External Angle	7	90° External Angle
3	135° Internal Angle	8	Gutter Length
4	Union Connector	9	Right Hand Stopped
5	Running Outlet		

Gutter Lengths

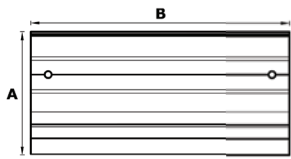

GUTTER SIZE A (W X D)	B	PRODUCT CODE
200 x 150	3000	86MOG3
200 x 150	2500	86MOG2.5
200 x 150	2000	86MOG2
200 x 150	1000	86MOG1
200 x 150	500	86MOG0.5



Faceted radius gutter available on request.

90° External Angle

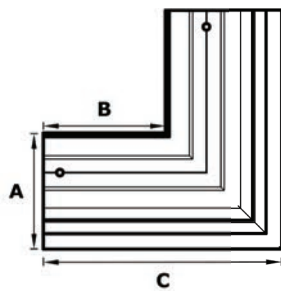

GUTTER SIZE A (W X D)	B	C	PRODUCT CODE
200 x 150	150	350	86MOAX90



Non standard angles available on request.

90° Internal Angle

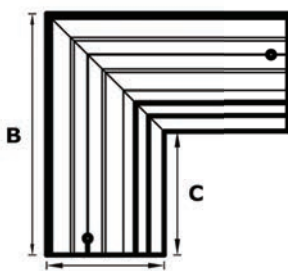

GUTTER SIZE A (W X D)	B	C	PRODUCT CODE
200 x 150	350	150	86MOAI90

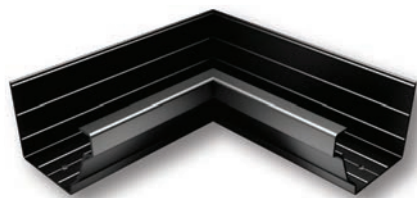

Non standard angles available on request.

All dimensions shown in mm unless otherwise stated.

**135° External Angle**

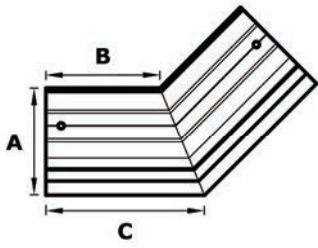

GUTTER SIZE A (W X D)	B	C	PRODUCT CODE
200 x 150	150	233	86MOAX135

Non standard angles available on request.



**135° Internal Angle**

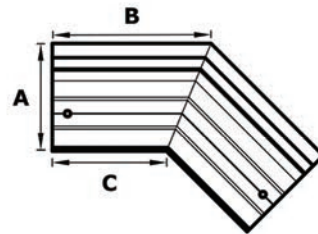

GUTTER SIZE A (W X D)	B	C	PRODUCT CODE
200 x 150	233	150	86MOAI135

Non standard angles available on request.

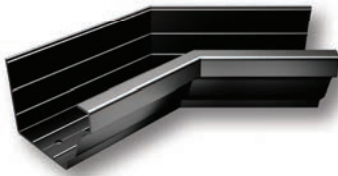

**Running Outlet**

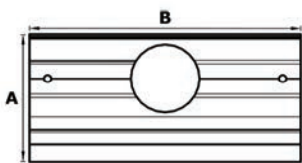

GUTTER SIZE A (W X D)	OUTLET SIZE	B	PRODUCT CODE
200 x 150	Ø63	300	86MOO2R
200 x 150	Ø76	300	86MOO3R
200 x 150	Ø101	300	86MOO4R
200 x 150	63 sq	300	86MOO2S
200 x 150	76 sq	300	86MOO3S
200 x 150	101 x 76	300	86MOO43
200 x 150	101 Sq	300	86MOO4S



Stopends

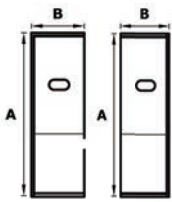

GUTTER SIZE A (W X D)	B	PRODUCT CODE LH	PRODUCT CODE RH
200 x 150	40	86MOSEL	86MOSER



Union Connector

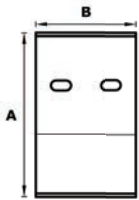

GUTTER SIZE A (W X D)	B	PRODUCT CODE
200 x 150	80	86MOUC



Looking for Cast Iron?

We have a full range of Gutters, Downpipes and Hoppers.



All dimensions shown in mm unless otherwise stated.

BEFORE YOU START

General Site Working

BS 8000 Workmanship on building sites, Parts 13 through to 16 with respect to above ground drainage and sanitaryware appliances are relevant in general terms.

Handling and Storage

Gutters, downpipes and fittings, particularly with polyester powder coat finish should be handled with care and preferably stored under cover on racks to prevent scratching. Whilst not known to pose any health hazard, it is recommended that protective gloves be worn when handling mill finish aluminium.

All lengths are supplied in a protective polythene wrapping with components similarly wrapped and stored in cardboard boxes. If painted product is to be stored outside, cover with a tarpaulin to protect against rainfall and direct sunlight. Failure to do this may allow water to get trapped inside the protective wrapper and could lead to permanent watermarks on the paint finish. Mill finish items should be stored under cover to avoid uneven oxidization prior to being fitted.

Cutting and Drilling

Gutter sections may be cut and drilled on site using standard metalworking tools, however the use of angle grinders is not recommended. Where gutters or fittings are powder coated, then cut edges should be de-burred and repainted with touch-up paint (available from ARP).

Setting Out

Gutters may be installed level or to a fall of 1:600. If level, make sure that the gutter is set at the correct height at the centre point and use a string line or level make a series of marks to indicate the correct height along the run length. When trying to achieve a fall the lowest point needs to be the outlet, so mark this position first, followed by the end of the run and then use a string line to mark regular points of reference.

Materials Checklist

- Spirit level/straight edge
- Suitable screwdriver/attachment
- Sealant caulking gun
- Pencil or chalk
- String or laser line
- Hacksaw/electric jigsaw/chopsaw
- Tape measure
- Small wrench

Jointing

Any use of sealant must not be carried out in wet weather or in temperatures below 5°C or above 50°C. All Joint surfaces must be perfectly clean and dry. Only a low modulus sealant must be used to prevent early failure. Ensure that the gutter joint sockets/spigots are correctly aligned with each other to ensure free thermal movement (3-4mm) within the gutter joint.

Fixing

It is important that all fixings are suitable for both the substrate and the load. They must therefore be of the appropriate size and of a compatible material to ensure no electrolytic corrosion occurs. ARP recommends that stainless steel (preferably austenitic) screws must be used to fix gutters, whether direct, fascia or rafter bracket fixed.

The below table shows the system and bracket options available.

	Fascia Brackets	Direct Fix	Rafter Brackets	Rise & Fall Brackets
Beaded Half Round	Y	N	Y	Y
Deepflow Half Round	Y	N	Y	Y
Vintage Ogee Snap-fit	Y	Y	Y	Y
Modern Ogee	N	Y	N	N

Gutter Position

The current recommendations from the Metal Gutter Manufacturers Association (MGMA) is to position gutters as Fig 1.

**Fig 1.** As the line of the roof passes the gutter, a good proportion of debris sliding down the roof, such as leaves or snow will pass by without being collected. This position will also reduce potential snow build up back up the roof, which can put additional strain on brackets and fascia board adhesion.

There are certain conditions where a Fig 1 installation might allow water to over shoot the gutter in high wind conditions however this is deemed to be better than the above stated issues.

**Fig 2.** As the line of the roof sits inside the gutter profile, this encourages

debris, such as leaves or snow, to be collected and could cause an increase in debris clearing regularity and issues with bracket and fascia board adhesion strength in heavy snow conditions.



### GUTTER FIXING

We advise that you ensure the fixing background (e.g fascia board) is securely fixed, level and able to support the weight of the gutter at full capacity and that the roof overhang is correct – see gutter position.

Buildings without fascias may need a different type of bracketry. ARP offer a range of brackets to suit most applications. ARP offer side and top fix rafter arms as well as rise and fall brackets. The latter do not meet current BS/EN load requirements so advice should be sort on the parameter of their use.

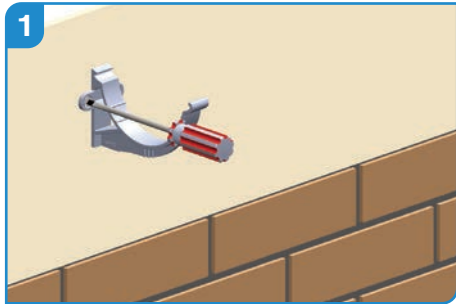

1 Start by deciding whether to fit the gutter level or with a fall to 1:600. Fit a bracket at each end of a run. Position brackets correctly for an angle or stepend.

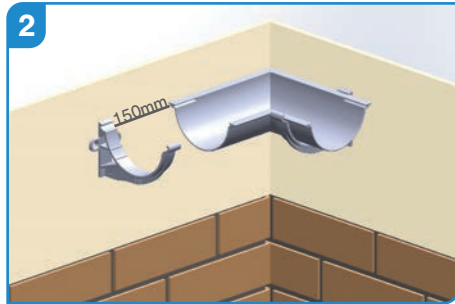

2 Image 2 shows the bracket positioning for the angle and bracket to take the gutter length.

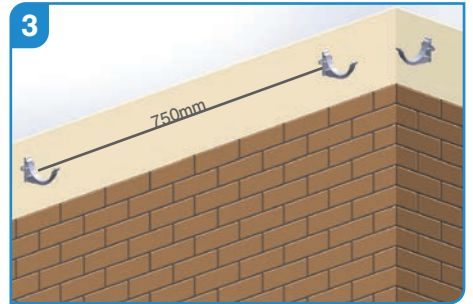

3 We recommend fixing brackets every 750mm and using an additional bracket for each outlet or angle. Ideally using a string line or laser level between the two brackets, set out intermediate brackets at maximum centres of 750mm.



4 With the use of a plumb or laser line, position outlets over gullies and support with at least one bracket. Also include a bracket per angle (internal or external).

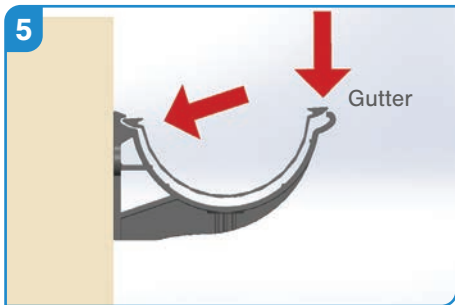

5 When fitting outlets and angles tuck the rear face of the gutter underneath the roof finish. Locate the gutter into the fascia bracket and then clip the front edge down into position.

After fitting outlets and angles, proceed with fitting the gutter lengths using the same method.

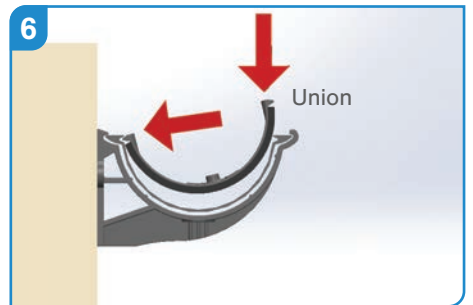

6 Ensure that all fixing surfaces are clean and dry. Placing the union into the groove in the rear face of the gutter and clip down into place on the front edge.



7 Trim 4-5 mm off top of nozzle so it fits snugly into the large holes in the base of the union, inject the special\* low modulus sealant supplied into one of the large holes in the bottom of the union until the sealant appears at both of the smaller holes at the rim of the union. Repeat the action on the other large hole. (\*Sealant only available from ARP).

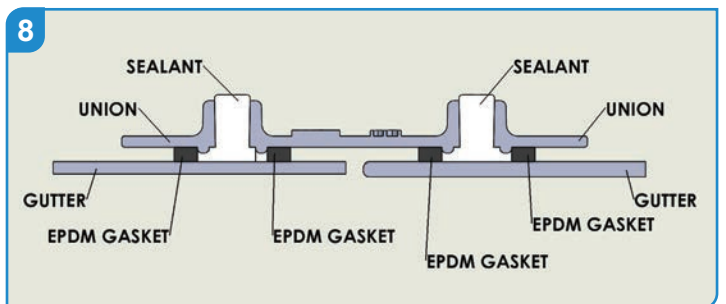

8 Ensure you apply the sealant gently to ensure the void is fully filled.

Clean off any excess sealant and then use the same process for every joint until the work is completed.



Any cut lengths should be de-burred and touched up with touch-up paint supplied prior to installation. For more information or further assistance, please contact us.

### GUTTER FIXING

We advise that you ensure the fixing background (e.g fascia board) is securely fixed, level and able to support the weight of the gutter at full capacity and that the roof overhang is correct – see gutter position.

Sentinel Deepflow guttering is fitted using fascia brackets. Buildings without fascias may need a different type of bracketry. ARP offer a range of brackets to suit most applications. ARP offer side and top fix rafter arms as well as rise and fall brackets. The latter do not meet current BS/EN load requirements so advice should be sort on the parameter of their use.

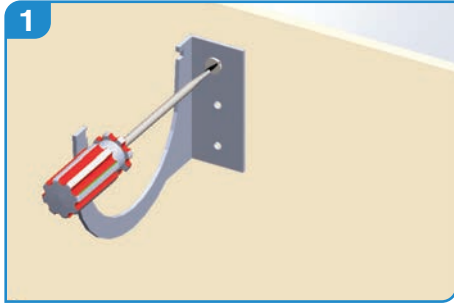

Start by deciding whether to fit the gutter level or with a fall to 1:600. Fit a bracket at each end of a run. Position brackets correctly for an angle or stopend.

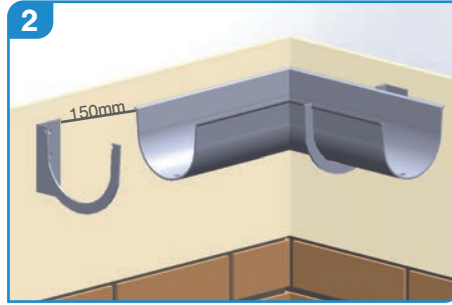
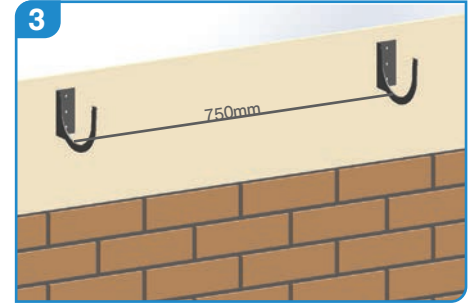
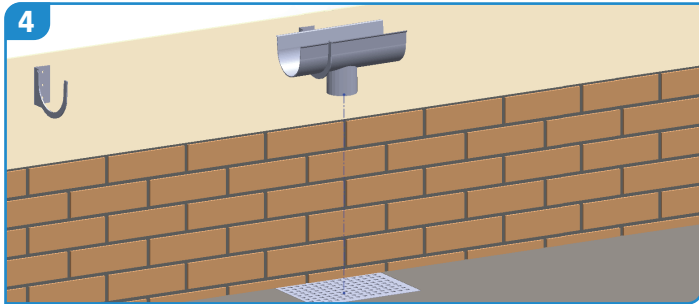

Image 2 shows the bracket positioning for the angle and bracket to take the gutter length.



We recommend fixing brackets every 750mm and using an additional bracket for each outlet or angle.

Ideally using a string line or laser level between the two brackets, set out intermediate brackets at maximum centres of 750mm.



With the use of a plumb or laser line, position outlets over gullies and support with at least one bracket. Also include a bracket per angle (internal or external).

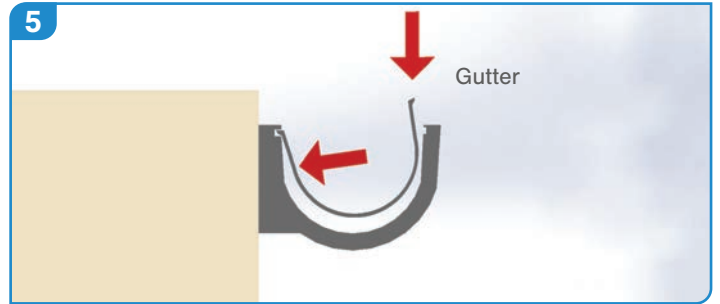

When fitting outlets and angles position the rear face of the gutter underneath the roof finish. Locate the gutter into the fascia bracket and then clip the front edge down into position.

After fitting outlets and angles, proceed with fitting the gutter lengths using the same method.



Ensure that all fixing surfaces are clean and dry. Apply 6mm bead of low modulus sealant to each side of the joint.

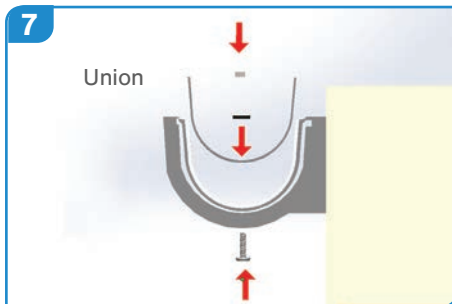

Push bolts through the sole of the gutter from the underside and position union into the gutter ensuring that the slotted holes in the union are filled with sealant as the union is pressed into place. Apply nuts and washers and gently tighten (Do not overtighten as this may force the sealant out of the joint).

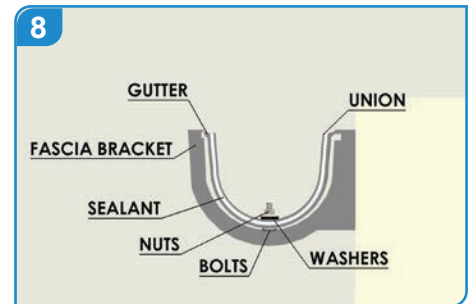

Clean off any excess sealant to either side of the joint or apply additional as required to create a smooth bead.



Any cut lengths should be de-burred and touched up with touch-up paint supplied prior to installation. For more information or further assistance, please contact us.

### GUTTER FIXING

We advise that you ensure the fixing background (e.g fascia board) is securely fixed, level and able to support the weight of the gutter at full capacity and that the roof overhang is correct – see gutter position.

Sentinel Vintage Ogee guttering is fitted using fascia brackets. Buildings without fascias may need a different type of bracketry. ARP offer a range of brackets to suit most applications. ARP offer side and top fix rafter arms as well as rise and fall brackets. The latter do not meet current BS/EN load requirements so advise should be sort on the parameter of their use.

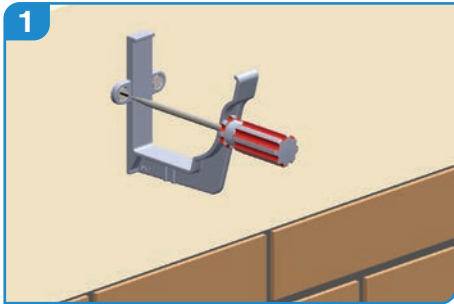

1 Start by deciding whether to fit the gutter level or with a fall to 1:600. Fit a bracket at each end of a run. Position brackets correctly for an angle or stopend.

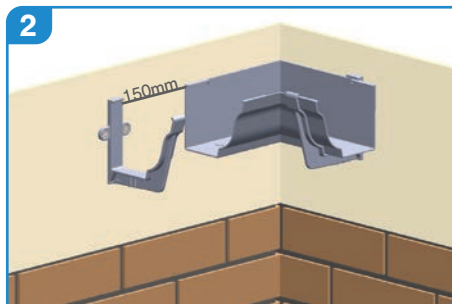

2 Image 2 shows the bracket for the angle and a bracket to take the gutter length.

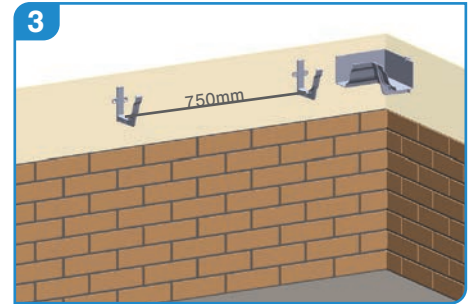

3 We recommend fixing brackets every 750mm and using an additional bracket for each outlet or angle. Ideally using a string line or laser level between the two brackets, set out intermediate brackets at maximum centres of 750mm.

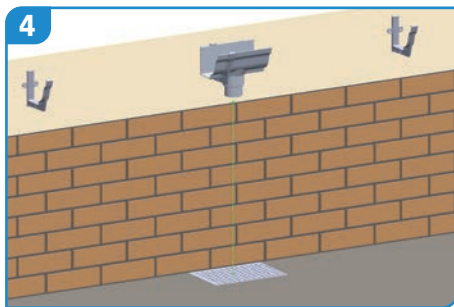

4 With the use of a plumb or laser line, position outlets over gullies and support with at least one bracket. Also include a bracket per angle (internal or external).

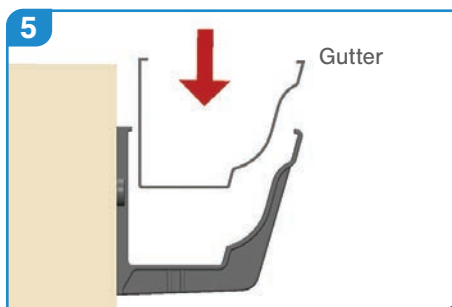

5 When fitting outlets and angles tuck the rear face of the gutter underneath the roof finish. Locate the gutter into the fascia bracket and then press down into position.

After fitting outlets and angles, proceed with fitting the gutter lengths using the same method.

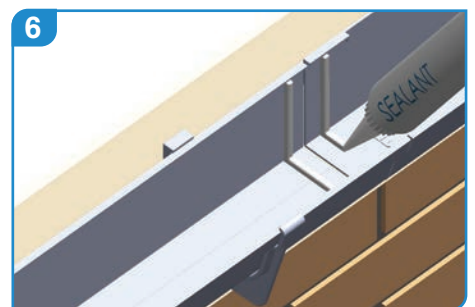

6 Ensure that all fixing surfaces are clean and dry. Place union adjacent to joint in gutter in preparation for fitting.

Apply a 6mm bead of low modulus sealant to each side of the joint.

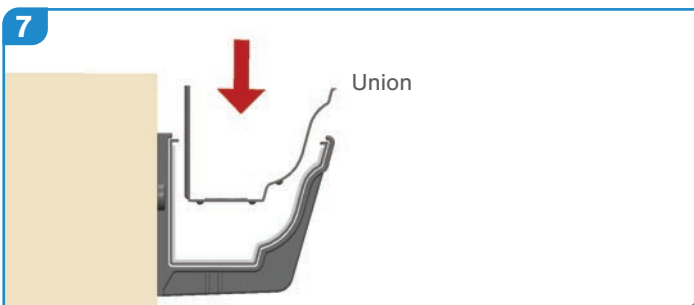

7 After sealant is applied to gutter surfaces place union over joint and press down firmly until the union clips into place on both front and rear face of the gutter.

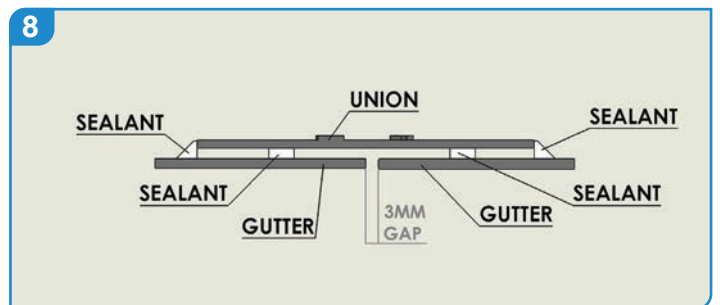

8 Clean off excess sealant along the edges of the joint. Use the same process for every joint until the work is completed



Any cut lengths should be de-burred and touched up with touch-up paint supplied prior to installation. For more information or further assistance, please contact us.

## GUTTER FIXING

We advise that you ensure the fixing background (e.g fascia board) is securely fixed, level and able to support the weight of the gutter at full capacity and that the roof overhang is correct – see gutter position.

Sentinel Modern Ogee guttering is a direct fix system, so no need for extra bracketry.

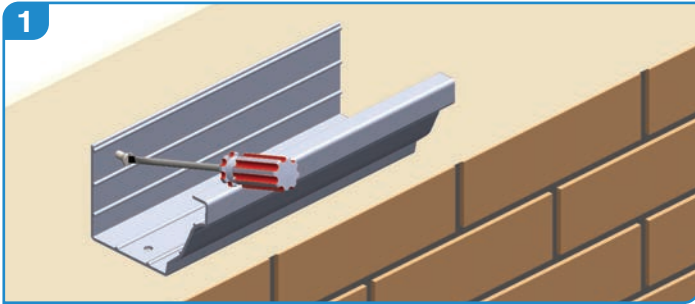

Modern Ogee is fitted direct to the fascia board at 600 mm centres and has pre-drilled holes for fixing. Start by deciding whether to fit the gutter level or with a fall to 1:600.

Ideally using a string line or laser level, set out position from bottom edge of gutter.

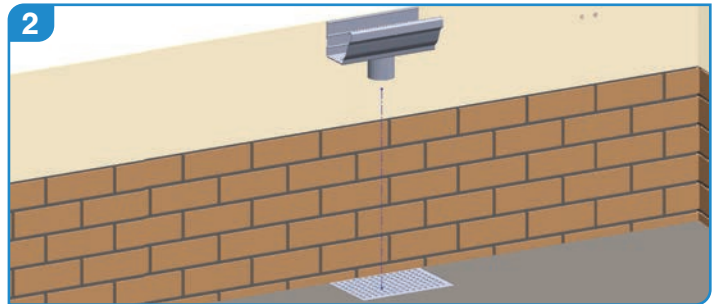

Fit outlets and angles first.

With the use of a plumb or laser line to set outlets over gullies. Fix gutter lengths utilising the pre-drilled fixing holes at 600 mm centres in the rear face of the gutter.



After outlets are positioned fit corners if applicable and then proceed to fit gutter lengths between corners and outlets.

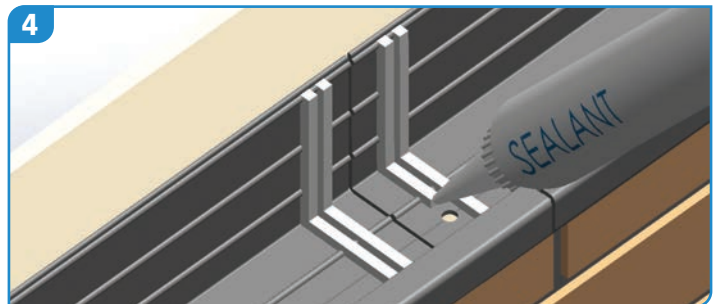

Place the union in the gutter adjacent to the joint.

Ensure that all fixing surfaces are clean and dry.

Apply 2 x 6mm beads of low modulus sealant to each side of the joint.

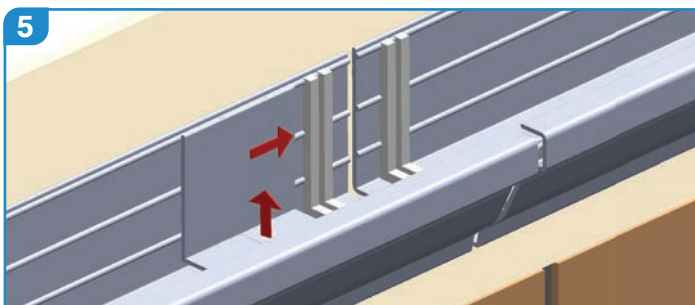

Push bolts through the sole of the gutter from the underside, lift and slide the union across the joint making sure the slotted holes in the union are filled with sealant as the union is pressed into place.

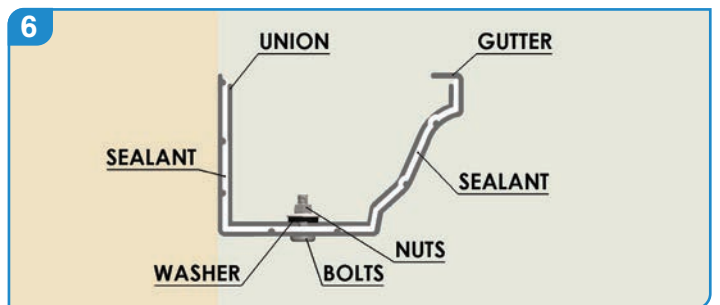

Apply nuts and washers and gently tighten (Do not overtighten as this may force the sealant out of the joint).

Clean off any excess sealant to either side of the joint or apply additional as required to create a smooth bead.



Any cut lengths should be de-burred and touched up with touch-up paint supplied prior to installation. For more information or further assistance, please contact us.

ACCESS FURTHER DOCUMENTS AND ARP'S LITERATURE

Visit [arp-ltd.com/services/download-centre](http://arp-ltd.com/services/download-centre)

**ARP**  
Metal Rainwater and Roofline Products

Images showing various gutter and roofline installations on different building styles.

Logos: BBA, MGA, BBA

**ARP**  
Metal Roofline and Rainwater Products

The sustainable and eco-friendly alternative to plastic.

Images showing gutter systems on a residential building.

Product comparison table for various gutter types:

Product	Profile Available	Cast Aluminium Gutters	Extruded Aluminium Gutters	Pressed Aluminium Gutters	Aluminium Rainwater Pipes	Facia, Soffits, Copings, Cappings and Bespoke Pressings	Cast Iron Gutters and Downpipes
LEGACY	Examples of profiles available	100mm x 25mm, 125mm x 25mm, 150mm x 25mm, 175mm x 25mm	100mm, 125mm, 150mm, 175mm	100mm, 125mm, 150mm, 175mm	100mm, 125mm, 150mm, 175mm	Bespoke profiles made in-house to exact measurements	100mm, 125mm, 150mm, 175mm
SENTINEL	Examples of profiles available	100mm x 25mm, 125mm x 25mm, 150mm x 25mm, 175mm x 25mm	100mm, 125mm, 150mm, 175mm	100mm, 125mm, 150mm, 175mm	100mm, 125mm, 150mm, 175mm	Bespoke profiles made in-house to exact measurements	100mm, 125mm, 150mm, 175mm
LEGION	Examples of profiles available	100mm x 25mm, 125mm x 25mm, 150mm x 25mm, 175mm x 25mm	100mm, 125mm, 150mm, 175mm	100mm, 125mm, 150mm, 175mm	100mm, 125mm, 150mm, 175mm	Bespoke profiles made in-house to exact measurements	100mm, 125mm, 150mm, 175mm
COLONNADE	Examples of profiles available	100mm x 25mm, 125mm x 25mm, 150mm x 25mm, 175mm x 25mm	100mm, 125mm, 150mm, 175mm	100mm, 125mm, 150mm, 175mm	100mm, 125mm, 150mm, 175mm	Bespoke profiles made in-house to exact measurements	100mm, 125mm, 150mm, 175mm
TRUELINE	Examples of profiles available	100mm x 25mm, 125mm x 25mm, 150mm x 25mm, 175mm x 25mm	100mm, 125mm, 150mm, 175mm	100mm, 125mm, 150mm, 175mm	100mm, 125mm, 150mm, 175mm	Bespoke profiles made in-house to exact measurements	100mm, 125mm, 150mm, 175mm
BRITANNIA	Examples of profiles available	100mm x 25mm, 125mm x 25mm, 150mm x 25mm, 175mm x 25mm	100mm, 125mm, 150mm, 175mm	100mm, 125mm, 150mm, 175mm	100mm, 125mm, 150mm, 175mm	Bespoke profiles made in-house to exact measurements	100mm, 125mm, 150mm, 175mm

E: [sales@arp-ltd.com](mailto:sales@arp-ltd.com) | [www.arp-ltd.com](http://www.arp-ltd.com)

**ARP**  
Sectional Price List April 2020

Images showing various gutter and roofline products.

ALUMINIUM & CAST IRON RAINWATER & ROOFLINE PRODUCTS

**COLONNADE** Square/Rectangular Swaged Pipes

Pipe Size (A x B)	Maximum Length	Weight (kg/m)	Product Code
50 x 50mm	0.5, 1.0, 1.5, 2.0, 2.5, 3.0m	0.8	ARP50
75 x 75mm	0.5, 1.0, 1.5, 2.0, 2.5, 3.0m	1.2	ARP75
100 x 100mm	0.5, 1.0, 1.5, 2.0, 2.5, 3.0m	1.8	ARP100
125 x 125mm	0.5, 1.0, 1.5, 2.0, 2.5, 3.0m	2.5	ARP125
150 x 150mm	0.5, 1.0, 1.5, 2.0, 2.5, 3.0m	3.2	ARP150

ARP Ltd. 0116 289 4400 | [www.arp-ltd.com](http://www.arp-ltd.com)

**MUSTANG** Seamless 5" Gutter

Product Description: Mustang Seamless aluminium gutters are the perfect alternative to UPVC. Backed by a BBA certificate, this superior system provides 30 years of maintenance free use.

Properties: Formed from 6061-T6 aluminium alloy 3102B HAS. Tested under BBA certificate no. 912825. Other sizes available. Coated with an Aluminium Resistant System (ARS) in a range of colours including: Black, White, Brown, Light and Dark Grey.

Installation: The main advantage of seamless gutters is that they do not have any joints, so the material is produced in lengths on site. When a corner or else end is required, leak free interlocking components are combined with the long lengths to create an endless length of up to 30 meters.

Functional Life Expectancy: When installed by an ARP Approved Installer, the BBA certificate states that the product will not require any maintenance for 30 years and has a life expectancy in excess of this period. Further information is available from the ARP website or BBA certificate no. 912825.

ARP Ltd. 0116 289 4400 | [www.arp-ltd.com](http://www.arp-ltd.com)

TECHNICAL PRODUCT GUIDES

**ARP** SENTINEL  
Technical Product Guide 2021

Images showing Sentinel gutter products.

SENTINEL

**ARP** LEGACY  
Technical Product Guide 2021

Images showing Legacy gutter products.

LEGACY

**ARP** BRITANNIA  
Technical Product Guide 2021

Images showing Britannia gutter products.

BRITANNIA

**ARP** LEGION  
Technical Product Guide 2021

Images showing Legion gutter products.

LEGION

**ARP** COLONNADE  
Technical Product Guide 2021

Images showing Colonnade gutter products.

COLONNADE