

CI/SIB	(21.9)	X16	
July 2013			



Channel and Bolt Fixings

for the Construction Industry

Ancon[®]
BUILDING PRODUCTS

Channel and Bolt Fixings



Ancon SD21 Channel Tie Fixed to Omega 21/18 Slot (CE) and MDC Support System (CE) Bolted to 30/20 Channel



AnconLock 41/27

Cast-in Channels

Cast-in Channels range from simple self-anchoring slots for accepting restraint fixings to large capacity channels with integral anchors (pages 5-6). They provide the necessary adjustment required when fixing to concrete and can eliminate site drilling. Nail holes aid the fixing of channels to timber formwork and an infill prevents the ingress of concrete during casting.

Cast-in fixings do not generate expansive forces in the concrete. They can therefore be used at close centres and can often be used closer to the edges than expansion fixings.

Ancon Cast-in Channels have been independently tested to the current British Standard BS 5080, Parts 1 and 2. The anchor shapes of Ancon Channels are outside current European Technical Assessment documents and therefore these products cannot be CE marked.

Omega

Patent No: 2249110

The Omega 21/18 Channel is a self-anchoring channel for use with Ancon wall ties referenced _21. The shallow depth of 18mm allows the channel to be used where there is reduced cover to the reinforcement. Nail holes aid the fixing of the channel to timber formwork. If steel formwork is to be used, or the formwork is to be surface-vibrated, please seek advice from Ancon's Technical Services Team.

30/20

Patent No: EP0882164B

Ancon 30/20 is a high performance channel. Its unique shape allows the applied load to be fed directly from the channel lips to the anchors and the more compact section size improves its fit between reinforcement. Specially designed T-head bolts ride up the sloping sides of the channel and securely lock behind the front lips. This channel also accepts standard 20mm wide wall ties. 30/20 is filled with continuously extruded closed-cell PE-LD foam. This material is removed easily in long sections and is 100% recyclable.

Ancon 30/20 should be used in preference to 38/17 channel as 30/20 is a high performance channel and its lower material content offers considerable cost benefits.

Contents

Range of Fixings	2-3
Channel Profiles	4
Cast-in Channels	5-6
Installation Guidance	7
Surface-Fixed Channels	8
Expansion Bolts	9-10
Bonded Anchors	11
Steelgrip	12
Set Screws	13
Self-Drilling Screws	13
Plug and Screw Fixings	14
Cast-in Sockets	14
Applications	15
Other Ancon Products	15

AnconLock

AnconLock has teeth cut into the returned lips of the channel. The 'T' head bolts used to fix to this channel have a matching serrated surface on the underside of the head which provides a high resistance to slip under shear load along the line of the channel.

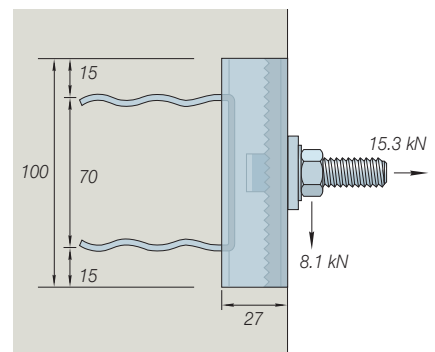

CombiDeck

Ancon CombiDeck has been developed for use with the permanent metal deck shuttering of steel frame structures. CombiDeck edge support is supplied with an integral channel section, usually 30/20 channel, built into the side to accept Ancon 'T' head bolts. More information on this product can be found in the Ancon Masonry Support Systems literature.

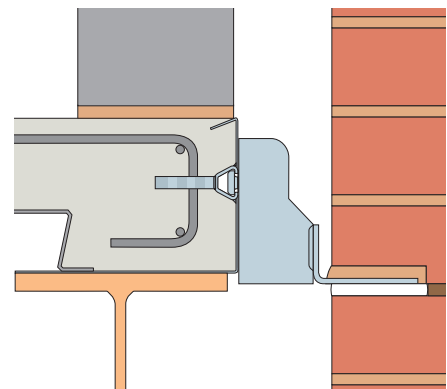

MDC Support System Fixed to CombiDeck Featuring 30/20 Channel

Surface-Fixed Channels

Plain-backed channels can be surface-fixed to steel, concrete and in some instances, masonry (page 8).

25/14

Ancon 25/14 accepts Ancon __ 25 wall ties and has been designed to tie masonry cladding to steel frames, including light section steel studwork. It is fixed to the steel at 450mm vertical centres with self-drilling screws (page 13). The channel is supplied with pre-punched holes at close centres to allow cutting on site and has a 16mm opening to accommodate a drive socket for the fixing screws. More information on this system, including wall tie spacing, is available in the Ancon Wall Ties and Restraint Fixings brochure.

Bolt Fixings

Expansion Bolts **CE**

The range consists of Single Expansion Bolts and High Performance Bolts. The latter have double expansion clips that reduce axial and edge spacings and will achieve high performance even in cracked concrete (pages 9-10).

Bonded Anchors **CE**

These fixings create a strong chemical bond between the anchor and the host material. Resin is supplied in either ready-mixed capsules or mixed on application from a cartridge (page 11).

Fixings for Steelwork

The Ancon Steelgrip simplifies the fixing of support systems to hollow steel sections where access is only available from one side (page 12). Stainless steel set screws and self-drilling screws are also available (page 13).

Cast-in Sockets

Sockets enable fixing to concrete where adjustment is either unnecessary or can be provided elsewhere (page 14).

Plug and screw fixings complete the range (page 14).

Corner Guards

Corner Guards offer protection to exposed edges of columns and walls in areas of high traffic such as car parks, warehouses, hospitals etc. Ancon manufactures corner guards in a standard length of 1250mm in either stainless steel, galvanised steel or untreated mild steel. Stainless steel provides the greatest corrosion resistance and, where aesthetics are important, can be supplied with a satin-polished surface finish. Corner guards can be either cast-in to concrete or post-fixed to almost any material. For more information please contact Ancon.

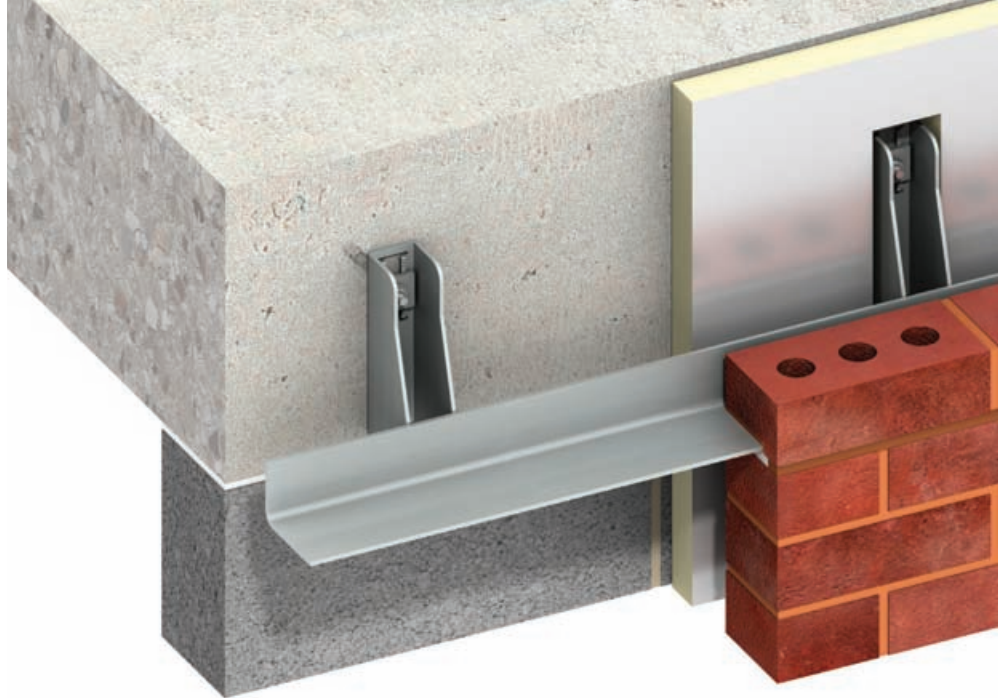

Ancon MDC System (**CE**) Fixed to Concrete with Single Expansion Bolts (**CE**)



Ancon 25/14 Channel System complete with SD25 Wall Tie (**CE**) and Self-Drilling Screw



Ancon Corner Guards

CE Marking

Construction products which fall within the scope of a harmonised European Standard must carry CE marking before they can legally be sold in the European Economic Area. Ancon complies with all requirements of this legislation and our literature identifies the products affected with a **CE** logo.

Channel and Bolt Fixings

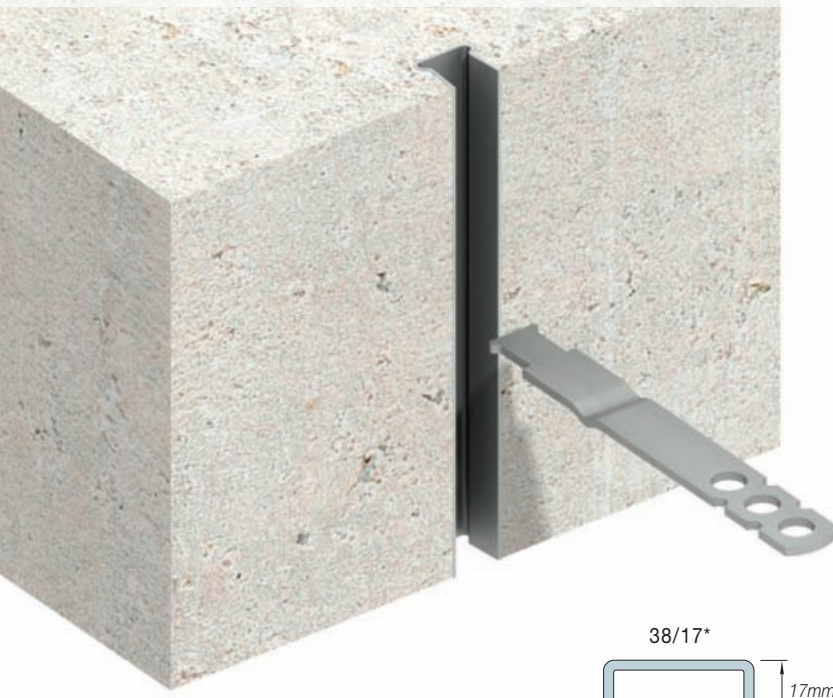

Ancon Channel

Ancon Channels are produced in a range of profiles, as illustrated.

21/18 - Omega

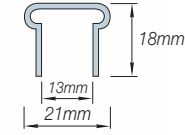

36/8

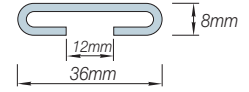

25/14

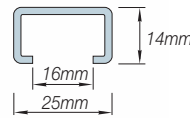

28/15

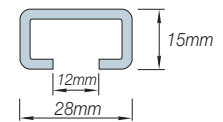

38/17*

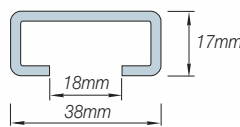

30/20*

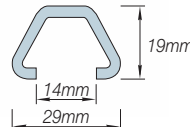

41/27 - AnconLock

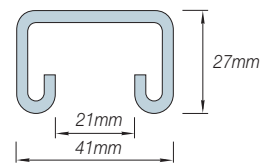

40/25

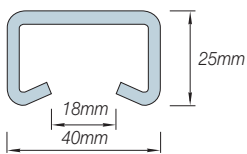

49/30

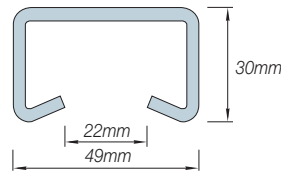

54/33

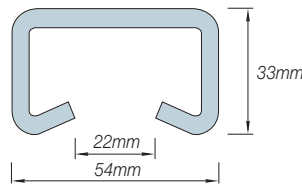

72/49

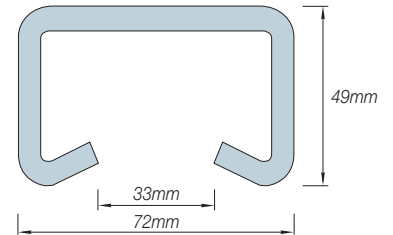

The table below shows channel lengths, availability and, where appropriate, the 'T' bolt required.

Product Range

Channel Reference	Standard Bolts	Preferred 'T' Bolt Length (mm)	Tightening Torque (Nm)	Other Size Bolts	Preferred Lengths (mm)	Stainless Steel 304	Stainless Steel 316/320	Carbon Steel	Hot-dipped Galvanised
21/18	-	-	-	-	100, 3000	✓	✗	✗	✗
36/8	-	-	-	-	1000, 2400, 3400	✓	✗	✗	✗
25/14	-	-	-	-	2700, 3000	✓	✓	✗	✗
28/15	M10	50, 100	20	-	100, 150, 3000	✓	✓	✓	✓
38/17*	M12	50, 100	30	M16 x 50	100, 150, 3000	✓	✓	✓	✓
30/20*	M12	50, 90	50	-	100, 150, 3000	✓	✗	✗	✗
40/25	M16	50	70	-	1000, 3000	✓	✓	✓	✓
41/27	M16	50, 80	70	-	100, 150, 200, 3000	✓	✗	✗	✗
49/30	M16	50	70	M12 x 50, M20 x 55	3000	✓	✓	✓	✓
54/33	M20	50	120	M12 x 50, M16 x 50	3000	✓	✗	✓	✓
72/49	M24	50, 100	200	-	3000	✗	✓	✓	✓

Notes: The recommended tightening torque is for the standard bolts. Hot-dip galvanised channels can be supplied in lengths up to 6000mm. *Ancon 30/20 should be used in preference to 38/17 channel. 30/20 is a high performance channel and its lower material content offers considerable cost benefits.

Section Properties

Channel References	25/14	28/15	36/8	38/17	40/25	41/27 AnconLock	49/30	54/33
Mass (Kg/m)	0.51	1.08	0.63	1.73	2.11	2.48	3.03	4.98
Area (cm ²)	0.64	1.36	0.79	2.19	2.67	3.14	3.84	6.30
I _{xx} (cm ⁴)	0.16	0.38	0.09	0.74	2.03	2.68	4.26	7.53
I _{yy} (cm ⁴)	0.60	1.37	1.13	3.93	6.09	7.31	13.15	22.75
Z _{xx} (cm ³)	0.17	0.43	0.16	0.74	1.38	1.73	2.41	3.95
Z _{yy} (cm ³)	0.48	0.98	0.63	2.07	3.04	3.56	5.37	8.42

Cast-in Channels

Channel Lugs

Channels are supplied with either integral double crimped lugs or single welded 'L' lugs, depending on the size of the channel. 'Bull Horn' lugs are welded at 90° to the line of the channel and can be specified as an alternative to the standard double crimped lugs.

Ancon Cast-in Channels have been independently tested to the current British Standard BS 5080, Parts 1 and 2. The anchor shapes of Ancon Channels are outside current European Technical Assessment documents and therefore these products cannot be CE marked.

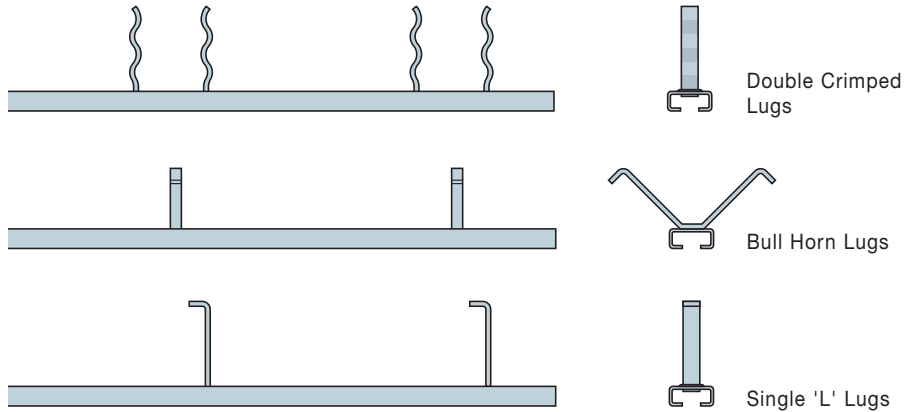

Channel Infill

All Ancon channels are supplied filled to help stop the ingress of concrete during casting. Expanded polystyrene is supplied in most channels. Ancon 30/20 is filled with continuously extruded closed-cell PE-LD foam. This material is removed easily in long sections and is 100% recyclable.

Ancon 30/20 Channel



Single 'L' Lugs

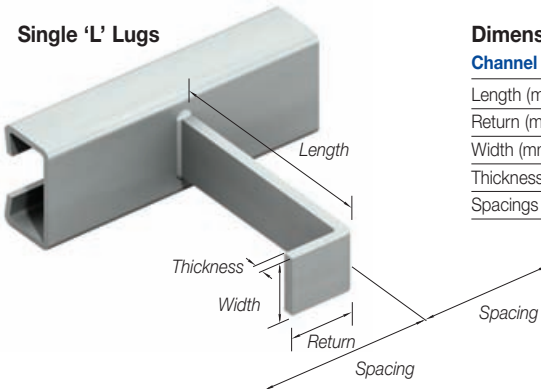

Dimensions

Channel Ref	54/33	72/49
Length (mm)	120	125
Return (mm)	35	35
Width (mm)	30	50
Thickness (mm)	6	6
Spacings (mm)	235	235

Double Crimped Lugs

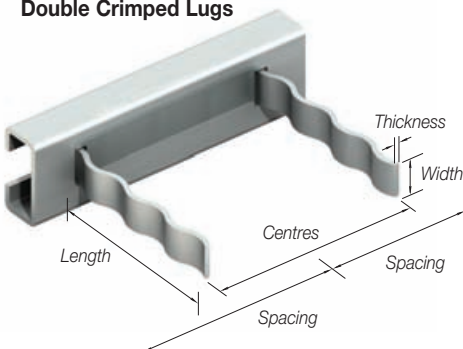

Dimensions

Channel Ref	28/15	38/17	30/20	40/25	41/27	49/30
Length (mm)	65	65	65	65	65	65
Centres (mm)	70	70	70	70	70	70
Width (mm)	11	15	11	15	20	20
Thickness (mm)	2.5	2.5	2.5	2.5	3.0	3.0
Spacings (mm)	235	235	220	235	235	235

Fixing to Channels

Fixing to channels is by 'T' head bolts. These are inserted into the channel and turned through 90°. The bolt must then be tightened to the correct torque. Tapped plate washers can be used as an alternative to 'T' bolts where non-standard bolt lengths or diameters are required.

T-Head Bolts Inserted into Channel and Turned Through 90°

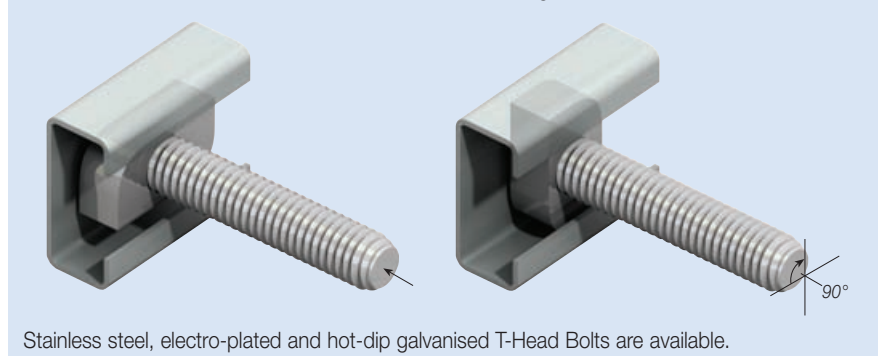

Stainless steel, electro-plated and hot-dip galvanised T-Head Bolts are available.

Channel and Bolt Fixings

Design Resistances

The design resistances are based on channels with standard anchors (page 5), cast into concrete with a strength of 30N/mm².

Longitudinal loads are achieved by friction using fully-tightened stainless steel or grade 4.6 bolts. AnconLock toothed channel should be used for most applications involving longitudinal loads.

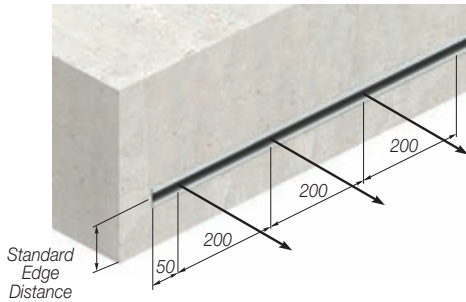

Design Resistances at Standard Edge Distances

Channel Reference	Edge Distance (mm)	Tension (kN)	Shear (kN)	Longitudinal (kN)	
28/15	50	5.8	5.8	1.4	
38/17*	75	9.5	10.8	2.7	
30/20*	75	10.1	10.8	2.7	
30/20 CombiDeck	Top Bottom	55 75	8.8	9.5	2.7
40/25	100	10.8	13.5	2.7	
41/27 - AnconLock	100	15.3	8.1	9.2	
49/30	150	16.2	18.9	2.7	
54/33	160	31.1	31.1	4.1	
72/49	250	36.5	36.5	10.8	

Note: The above values should be used in conjunction with the appropriate Eurocode safety factors. $\gamma_G=1.35$ $\gamma_Q=1.5$

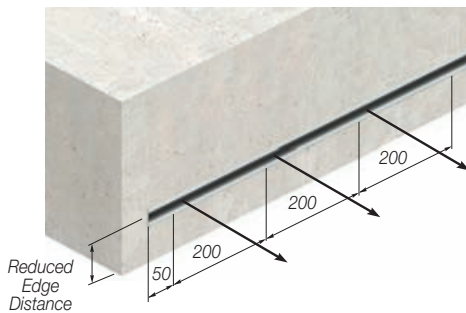

Design Resistances at Reduced Edge Distances

Channel Reference	Edge Distance (mm)	Tension (kN)	Shear (kN)	Longitudinal (kN)
28/15	40	5.4	5.4	1.4
38/17*	60	6.8	8.1	2.7
30/20*	60	8.1	8.1	2.7
40/25	80	10.1	12.2	2.7
41/27 - AnconLock	100	15.3	8.1	9.2
49/30	120	13.5	13.5	2.7
54/33	160	31.1	31.1	4.1
72/49	250	36.5	36.5	10.8

Note: The above values should be used in conjunction with the appropriate Eurocode safety factors. $\gamma_G=1.35$ $\gamma_Q=1.5$

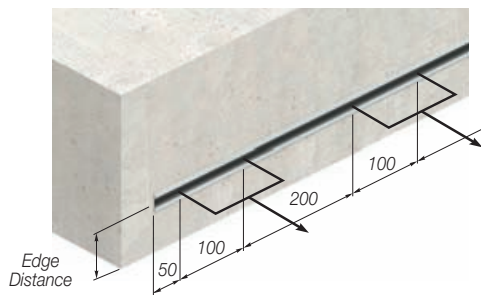

Design Resistances Bolt Pairs

Channel Reference	Edge Distance (mm)	Tension (kN)	Shear (kN)
28/15	50	9.5	9.5
38/17*	75	12.2	12.2
30/20*	75	13.5	16.2
40/25	100	16.2	16.2
41/27 - AnconLock	100	21.6	18.4**
49/30	150	20.3	20.3
54/33	160	33.8	33.8
72/49	250	36.5	36.5

** Longitudinal Load

Note: The above values should be used in conjunction with the appropriate Eurocode safety factors. $\gamma_G=1.35$ $\gamma_Q=1.5$

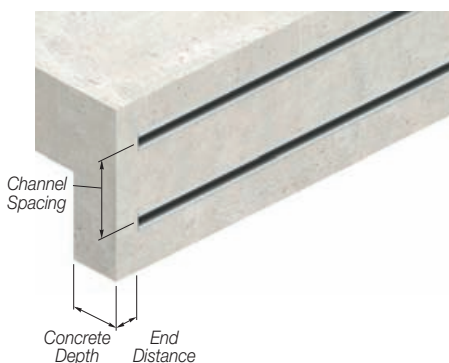

Minimum Channel Position Dimensions

Channel Reference	End Distance (mm)	Spacing (mm)	Concrete Depth (mm)
28/15	50	100	95
38/17*	50	150	95
30/20*	50	150	95
40/25	80	200	100
41/27 - AnconLock	50	200	100
49/30	130	300	105
54/33	175	320	165
72/49	225	500	185

Notes: The design resistances shown in the tables above are for channels using the standard bolts. *Ancon 30/20 should be used in preference to 38/17 channel. 30/20 is a high performance channel and its lower material content offers considerable cost benefits.

Design Example

Cast-in channel with combined tension and shear loads

Design Action Tension	=	3.7kN	
Design Action Shear	=	4.2kN	
Design Resistance Tension	=	10.1kN	
Design Resistance Shear	=	10.8kN	
Resultant Action	=	$\sqrt{3.7^2 + 4.2^2}$	= 5.60kN
Angle	=	$\tan^{-1} \times (3.7/4.2)$	= 41.38°

Note: Angle greater than 15° therefore compare Resultant Action with Design Resistance Tension.

Proof:

Design Action Tension	≤	Design Resistance Tension	OK
Design Action Shear	≤	Design Resistance Shear	OK
Resultant Action	≤	Design Resistance Tension	OK

Therefore use: 30/20 Cast-in channel with M12 T-head bolts.

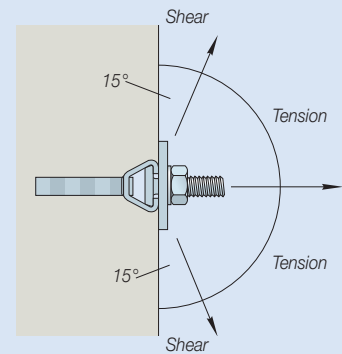

Installation Guidance

Cast-in Channels

Fixing to Timber Formwork

Ancon Cast-in Channels are normally supplied in 3000mm lengths with welded anchors, nail holes, and infill. Incorrect installation is likely to result in expensive remedial work. All nail holes need to be utilised (except with Omega Channel), to prevent excessive ingress of concrete fines between the formwork and the channel during casting.

Both nail holes should be utilised when fixing 21/18 Omega Channel 100mm long to timber formwork. Longer lengths of this channel should be nailed at each end and then fixed at 300mm centres.

Nails with a plain shank should be installed perpendicular to the channel to ensure the easy removal of the formwork and the retention of the channel in the concrete.

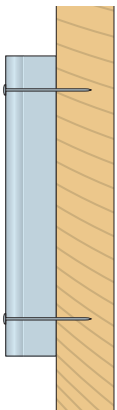

Channel Nailed to Formwork

Fixing to Steel Formwork

Channels can be secured to steel formwork by using standard 'T' head bolts in pre-drilled holes. Where metal deck floors are being used, Ancon CombiDeck has a built-in channel and will replace the standard edge trim.

Welded Fabrications

Where channels with welded anchors are cut on site, it is important to ensure that there is a whole anchor within 50mm from the end of the channel.

Where horizontal cast-in channel is used in conjunction with brickwork support systems, all external corners must incorporate a Welded Corner Fabrication. Release oil must not be applied to either the channel or the anchor.

Minimum Edge Distance

Care should be taken to ensure that the dimensions from the centre of the channel to the edges of the concrete are not less than the minimum edge distance shown on page 6. The channel must be lined and levelled correctly. In every situation, care must be taken to ensure a good fit is obtained between the face of the channel and the formwork.

Removal of Formwork

When the concrete is poured, care should be taken to ensure that it is fully compacted around the back of the channel and especially adjacent to anchors. After the concrete has cured and the formwork is removed, the nails should either be cut off or bent away from any tie or 'T' head bolt.



Correct installation where channels are butted together. Max. distance from end of channel to first lug is 50mm

Channel and Bolt Fixings



Surface-Fixed Channel with Welded Plate Bolted to Concrete

Surface-Fixed Channels

Ancon channels can be supplied with holes for surface fixing to concrete, steelwork and other materials. The design resistance will depend on the fixing centres, the type of fixing and the base material.

Channels are supplied plain-backed for surface fixing to either concrete or steelwork. When bolting channel to concrete or steelwork it is important to utilise all fixing holes (except with 25/14 channels), incorporating the square washer provided and ensuring its correct orientation to achieve the design resistances.

Bolt and washer specifications are shown below and bolts should be installed following the guides on page 9 and 10.



Surface-Fixed Channel Bolted to Concrete



Surface-Fixed Channel Fixed with a T-Head Bolt to Cast-in Channel

Bolt and Washer Specifications

Channel	Bolt Diameter	Washer
28/15	M8	25 x 25 x 3
38/17	M10	30 x 30 x 3
40/25	M12	40 x 40 x 4
41/27	M16	40 x 40 x 4
49/30	M16	50 x 50 x 5
54/33	M20	50 x 50 x 5

Design Resistances

The design resistances for surface-fixed channels in the table below assume partial fixity ($M=WL/6$) and are limited by either a maximum stress of $240N/mm^2$ or a deflection of $span/325$.

Design resistances for other spans and/or different end fixity can be calculated using the section properties shown on page 4.

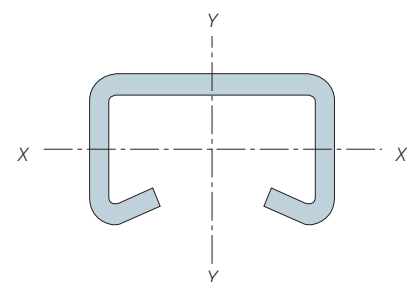

Surface-Fixed Channel References	Fixing Centres (mm)	28/15	38/17	40/25	41/27 AnconLock	49/30	54/33
Design Resistances (kN)	150	4.13	7.10	11.20	15.82	16.80	32.20
	200	3.10	5.33	9.94	12.46	16.80	28.44
	300	2.06	3.55	6.62	8.30	11.57	18.96
	450	1.38	2.37	4.42	5.54	7.71	12.64
	600	0.98	1.78	3.31	4.15	5.78	9.48

Expansion Bolts

FBNII Single Expansion Through Bolts

Single Expansion bolts fix into a hole which is similar to the diameter of the bolt. This allows the hole to be drilled through the hole in the item to be fixed. The Single Expansion bolt is a cost-effective anchor, available in grade A4 316 (1.4401 or 1.4571) stainless steel in a wide range of sizes.

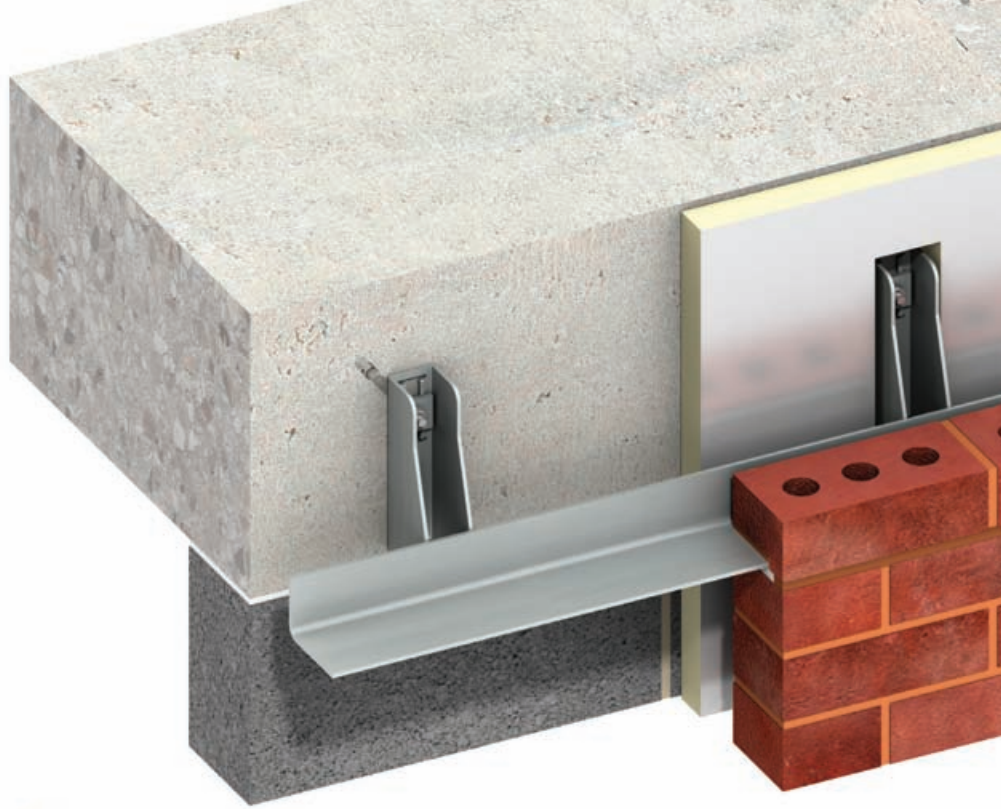

FBNII Expansion Bolts should be specified in accordance with the design procedures described in ETAG001 Annex C: Design Methods for Anchorages. FBNII bolts carry a European Technical Approval (ETA-07/0211) and are suitable for use in un-cracked concrete within the strength class range of C20/25 to C50/60. Design resistances should be calculated for each individual application. For guidance on specific applications please contact Ancon.

Bolt Reference	FBNII 6/10	FBNII 8/10	FBNII 10/20	FBNII 10/50	FBNII 12/20	FBNII 12/50	FBNII 16/25	FBNII 16/50
Thread Size	M6	M8	M10	M10	M12	M12	M16	M16
Overall Length (mm)	55	71	96	126	116	146	145	170
Hole Dia. In Concrete (mm)	6	8	10	10	12	12	16	16
Hole Dia. in Fixture (mm)	6.5	9	11	11	13	13	17	17
Min. Embedment (mm)	30	40	50	50	65	65	80	80
Width Across Nut (mm)	10	13	17	17	19	19	24	24
Tightening Torque (Nm)	4	10	20	20	35	35	80	80
Max. Fixing Thickness (mm)	10	10	20	50	20	50	25	50

Before Installation

The following checks must be carried out prior to the installation of Single Expansion Bolts.

- 1** The appropriate length and diameter drill bit is used.
- 2** The correct edge distance and spacing are used in accordance with the design requirements.
- 3** The anchor/fixing is the correct size.
- 4** The correct setting tools are used.

Installation

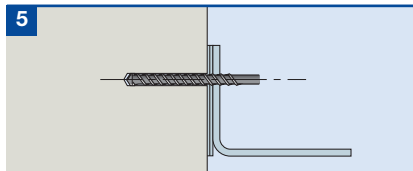

Drill the hole, through the pre-drilled hole in the fixture, into the concrete. This hole should be drilled perpendicular to the substrate surface, and to the correct diameter and depth. All dust and loose material should be removed from the hole using a wire brush or blow pump.

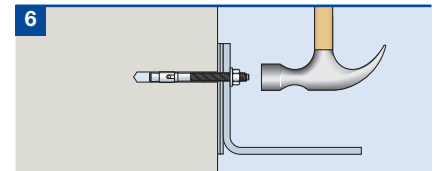

Lightly tap the throughbolt with a hammer through the fixture and into the hole, until the fixing depth is reached.

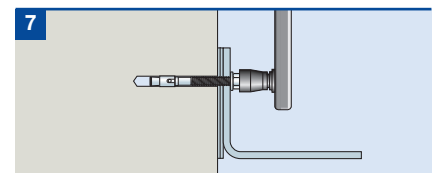

Tighten bolt to the recommended torque.

Channel and Bolt Fixings



FAZII High Performance Bolts

These are high performance through bolts manufactured in grade A4 316 (1.4401 or 1.4571) stainless steel. They have double expansion clips that reduce axial and edge spacing and achieve high performance even in cracked concrete.

They fix into a hole which is similar to the diameter of the bolt. This allows the hole to be drilled through the hole in the item to be fixed.



FAZII Expansion Bolts should be specified in accordance with the design procedures described in ETAG001 Annex C: Design Methods for Anchorages. FAZII bolts carry a European Technical Approval (ETA-05/0069) and are suitable for use in cracked and un-cracked concrete within the strength class range of C20/25 to C50/60. Design resistances should be calculated for each individual application. For guidance on specific applications please contact Ancon.

Bolt Reference	FAZII 8/10	FAZII 10/10	FAZII 10/30	FAZII 12/30	FAZII 12/50	FAZII 16/25	FAZII 16/50
Thread Size	M8	M10	M10	M12	M12	M16	M16
Overall Length (mm)	75	95	115	130	150	148	173
Hole Dia. In Concrete (mm)	8	10	10	12	12	16	16
Hole Dia. In Fixture (mm)	9	11	11	13	13	17	17
Min. Embedment (mm)	45	60	60	70	70	85	85
Width Across Nut (mm)	13	17	17	19	19	24	24
Tightening Torque (Nm)	20	45	45	60	60	110	110
Max. Fixing Thickness (mm)	10	10	30	30	50	25	50

Before Installation

The following checks must be carried out prior to the installation of High Performance Bolts.

- 1** The appropriate length and diameter drill bit is used.
- 2** The correct edge distance and spacing are used in accordance with the design requirements.
- 3** The anchor/fixing is the correct size.
- 4** The correct setting tools are used.

Installation

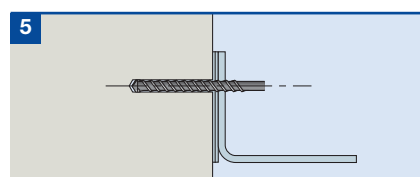

Drill the hole, through the pre-drilled hole in the fixture, into the concrete. This hole should be drilled perpendicular to the substrate surface, and to the correct diameter and depth. All dust and loose material should be removed from the hole using a wire brush or blow pump.

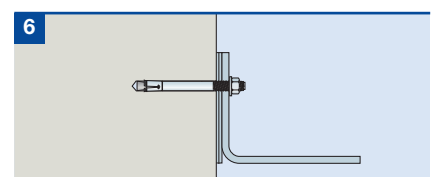

Insert the bolt through the component to be fixed and into the concrete. Add any packing shims that may be required.

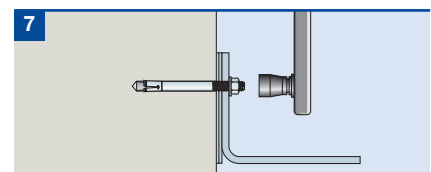

Tighten bolt to the recommended torque.

Bonded Anchors

Capsule Anchors

The capsule contains epoxy resin, quartz granules and a hardener, and provides an expansion-free anchorage for the stainless steel studs. These can be used in a variety of solid materials including un-cracked concrete, stone and masonry. Resin options are available for cracked and uncracked concrete.

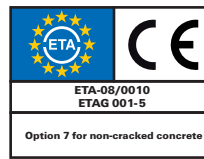

Bonded anchors should be specified in accordance with the design procedures described in EOTA Technical Report TR029: "Design of Bonded Anchors". Design resistance should be calculated for each individual application. For guidance on specific applications please contact Ancon.

Anchor Reference	FCS RM08/13-110	FCS RM10/20-130	FCS RM12/25-160	FCS RM16/35-190	FCS RM20/65-260
Thread Size	M8	M10	M12	M16	M20
Overall Length (mm)	110	130	160	190	260
Hole Dia. in Concrete (mm)	10	12	14	18	25
Hole Dia. in Fixture (mm)	9	11	13	17	22
Normal Embedment (mm)	80	90	110	125	170
Tightening Torque (Nm)	10	20	40	60	120
Max. Fixing Thickness (mm)	13	20	25	35	65

Injection Anchors

The cartridge contains a two-part system of vinylester resin and hardener which mixes in the nozzle during pumping. The general purpose resin can be used with most materials including un-cracked concrete, blockwork and brickwork. Resin options are available for cracked and uncracked concrete.

For guidance on specific applications please contact Ancon.

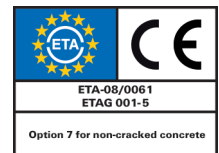

Anchor Reference	FIS VT06/10-75	FIS VT08/13-110	FIS VT10/20-130	FIS VT12/25-160	FIS VT16/35-190	FIS VT20/65-260
Thread Size	M6	M8	M10	M12	M16	M20
Overall Length (mm)	75	110	130	160	190	260
Hole Dia. in Concrete (mm)	8	10-12	12-14	14-16	18-20	24
Hole Dia. in Fixture (mm)	6.5	9	11	13	17	22
Normal Embedment (mm)	50	80	90	110	125	170
Tightening Torque (Nm)	5	10	20	40	60	120
Max. Fixing Thickness (mm)	17	13	20	25	35	65

Channel and Bolt Fixings



Fixings for Steel Frames

Ancon Steelgrip

Ancon Steelgrip is a high performance fixing, which simplifies the fixing of masonry support systems to hollow steel sections, or other applications where access is only available from one side.

This bolt is only available for use with Ancon systems. It features a serrated washer that corresponds with the serrations on all Ancon brackets. The serrated surfaces interlock, and as the head is tightened to the correct torque the sleeve expands.

The Steelgrip consists of a zinc plated sleeve and cone, and a stainless steel screw and serrated washer.



UK Patent No: 2410307

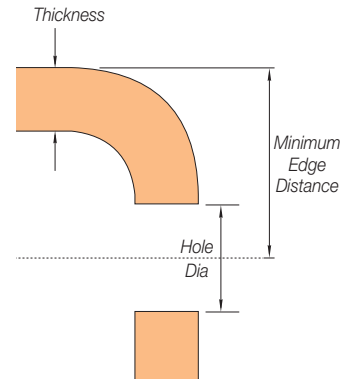

Minimum Edge Distance (mm)

Thickness (mm)	6	8	10
Ancon Steelgrip 12	24	26	28

Note: Minimum spacing 50mm

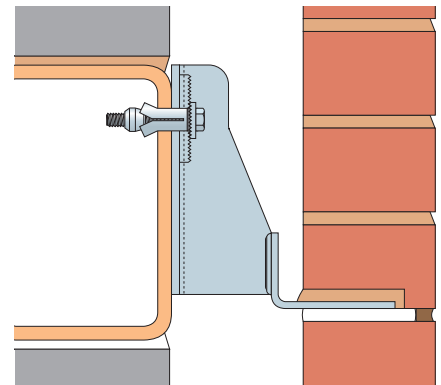

	Thread Size (mm)	Max. Shims (mm)	Overall Length (mm)	Resistance Tension (kN)	Resistance Shear (kN)	Steelwork Hole Dia. (mm)	Fixture Hole Dia. (mm)	Bolt Torque (Nm)
Ancon Steelgrip 12	M12	16	70	20.3	13.5	20	20	80

Note: Steelgrip is only for use with Ancon Systems.

Design Guidance

The design resistances shown are static loads in either tension or shear, however in many applications the anchor will be subject to a combination of shear and tension. The combined actions must satisfy the following equation:

$$\frac{\text{Design Action Tension}}{1.4 \times \text{Design Resistance Tension}} + \frac{\text{Design Action Shear}}{\text{Design Resistance Shear}} \leq 1.0$$

Before Installation

The following checks must be carried out prior to the installation of Ancon Steelgrip.

- 1** The appropriate diameter drill bit is used.
- 2** The correct edge distance is used in accordance with either the information in the table or that specified on drawings produced by Ancon Building Products.
- 3** The correct setting tool is used.

Installation

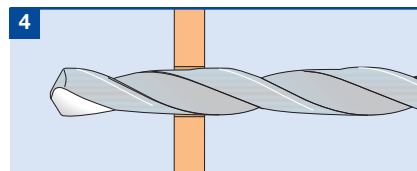

Drill hole to correct size as stated.

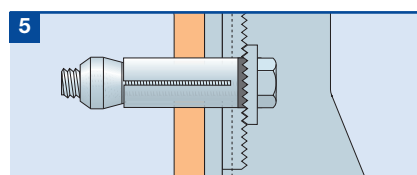

Insert the fixing through the fixture and into the pre-drilled hole ensuring the serrations are the correct orientation to interlock.

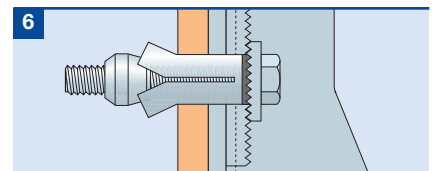

Begin to tighten with torque wrench. Adjustments to the line and level of the fixture can be made before the bolt has been fully tightened. Fully tighten to the recommended torque.

Set Screws

Ancon stainless steel set screws, nuts and washers are available in a range of thread sizes (M6 to M20) and are manufactured from grades A2 (1.4301) and A4 (1.4401) stainless steel, property class 70. Set screws can be shrink-wrapped and are supplied complete with nylon washers to prevent bi-metallic corrosion when fixing to steel.

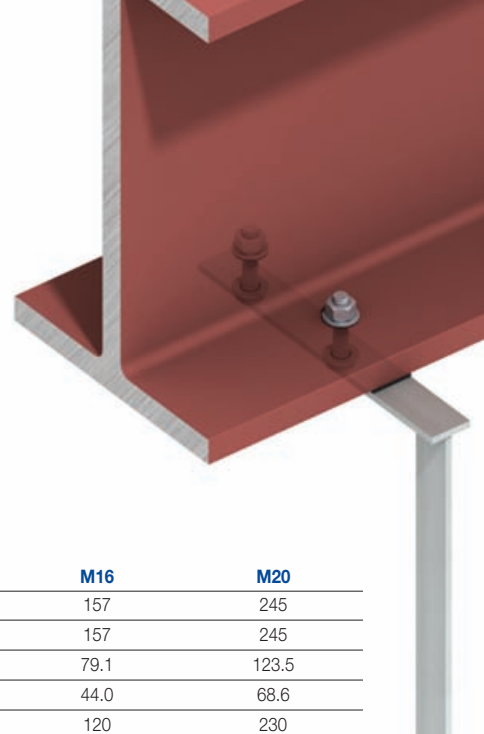

Bolt Reference	M6	M8	M10	M12	M16	M20
Area of Shank (mm ²)	28	36	58	84	157	245
Area of Root Thread (mm ²)	20	36	58	84	157	245
Resistance Tension (kN)	10.1	18.5	29.2	42.5	79.1	123.5
Resistance Shear (kN)	5.6	10.3	16.2	23.6	44.0	68.6
Tightening Torque (Nm)	6	14	27	48	120	230

Design Guidance

The design resistances above have been calculated in accordance with BS EN 1993-1-8: 2005. The values given make no allowance for prying effects.

The design resistances shown are static loads in either tension or shear, however in many applications the anchor will be subject to a combination of shear and tension. The combined actions must satisfy the following equation:

$$\frac{\text{Design Action Tension}}{1.4 \times \text{Design Resistance Tension}} + \frac{\text{Design Action Shear}}{\text{Design Resistance Shear}} \leq 1.0$$

Self-Drilling Screws

These screws feature a shaped drill tip of hardened steel that allows installation without pre-drilling. High thread screws accommodate insulation between a surface-fixed channel and the steel frame.

Self-drilling screws should be fixed using a driver with a speed of around 1800rpm. Drive sockets are available.



	Material Thickness	SDTSS-38-5PT	SDTCS-38-5PT-W	SDTSS-35-2PT	SDTSS-55-2PT
Material		Stainless Steel	Coated Steel	Stainless Steel	Stainless Steel
Diameter (mm)		5.5	5.5	5.5	5.5
Length (mm)		38	38	35	55
Drilling Capacity (mm)		4.0-12.0	4.0-12.0	1.2-3.2	1.2-3.2
Resistance Tension (kN)	1.2mm	-	-	1.16	1.16
	1.4mm	-	-	1.54	1.54
	1.6mm	-	-	1.68	1.68
	1.8mm	-	-	2.09	2.09
	2.0mm	-	-	2.60	2.60
	2.5mm	-	-	3.52	3.52
	3.0mm	-	-	4.10	4.10
	4.0-12.0mm	6.45	8.84	-	-
Resistance Shear (kN)		3.75	4.70	3.75	3.75
Insulation/Material Thickness		0-10mm	0-13mm	0-16mm	0-30mm

Material Thickness	High Thread Stainless Steel Screws					High Thread Carbon Steel Screws			
	HTSS-65-2PT-W	HTSS-82-2PT-W	HTSS-100-2PT-W	HTSS-115-2PT-W	HTSS-135-2PT-W	HTCS-65-2PT-W	HTCS-85-2PT-W	HTCS-115-2PT-W	HTCS-135-2PT-W
Material	Stainless Steel	Stainless Steel	Stainless Steel	Stainless Steel	Stainless Steel	Coated Steel	Coated Steel	Coated Steel	Coated Steel
Diameter (mm)	5.5	5.5	5.5	5.5	5.5	5.5	5.5	5.5	5.5
Length (mm)	65	82	100	115	135	65	85	115	135
Drilling Capacity (mm)	1.2-3.2	1.2-3.2	1.2-3.2	1.2-3.2	1.2-3.2	1.2-3.2	1.2-3.2	1.2-3.2	1.2-3.2
Resistance Tension (kN)	1.2mm	1.28	1.28	1.28	1.28	1.21	1.21	1.21	1.21
	1.4mm	1.63	1.63	1.63	1.63	1.58	1.58	1.58	1.58
	1.6mm	1.83	1.83	1.83	1.83	1.75	1.75	1.75	1.75
	1.8mm	2.12	2.12	2.12	2.12	2.08	2.08	2.08	2.08
	2.0mm	2.64	2.64	2.64	2.64	2.39	2.39	2.39	2.39
	2.5mm	3.79	3.79	3.79	3.79	3.86	3.86	3.86	3.86
	3.0mm	4.75	4.75	4.75	4.75	4.52	4.52	4.52	4.52
Resistance Shear (kN)	3.75	3.75	3.75	3.75	3.75	4.50	4.50	4.50	4.50
Insulation/Material Thickness	35-50mm	35-61mm	43-79mm	60-94mm	65-114mm	35-50mm	45-70mm	55-100mm	75-120mm

Notes: A factor of safety of 2.0 has been applied to ultimate values to determine design resistances

Channel and Bolt Fixings



Plug and Screw Fixings

The SX8 plug is manufactured from high quality nylon and is resistant to weathering, ageing and rotting. It requires an 8mm diameter hole and is suitable for use in various types of block as well as concrete. The fixing into the SX plug is a stainless steel hex head screw.



The load performance will depend on the substrate. Please contact Ancon for more information.

Cast-in Sockets

These sockets offer a simple solution to fixing into concrete for locations where adjustment is either unnecessary or can be provided elsewhere. Other sizes and lengths can be supplied in addition to the standard range. Ancon Cast-in Sockets should not be used as part of a lifting system.



Cast-in Sockets	10/75	12/75	16/75	20/75	24/100
Thread Size	M10	M12	M16	M20	M24
Overall Length (mm)	75	75	75	75	100
Design Resistance Tension (kN)	8.4	12.2	22.8	31.1	40.5
Design Resistance Shear (kN)	5.3	7.7	14.6	23.0	32.1
Outside Diameter (mm)	16	20	22	26	35
Cross Pin Length (mm)	50	75	75	88	100
Cross Pin Diameter (mm)	6	10	10	12	16
Centre of Cross Pin to End of Socket (mm)	10	12	15	16	20
Minimum Edge Distance (mm)	75	75	75	75	100
Minimum Spacing (mm)	150	150	150	150	200

Note: The published design resistances are based on tests using unreinforced concrete with a strength of 30N/mm², incorporating a dense gravel aggregate. However crushing strength is no guide to concrete strength in either shear or tension, and concrete with a similar compressive strength but with a different aggregate may not achieve the same performance. Providing suitable reinforcement is incorporated around the sockets, the published values will provide a sufficient factor of safety for concrete with different characteristics.

Applications



Retail Development
Buchanan Galleries, Glasgow, UK



Deutsche Bank
Sydney NSW, Australia



Magistrates Court
Mansfield, UK



Mixed-Use Development
Tottenham Court Road, London, UK

Other Ancon Products

Wall Ties and Restraint Fixings

Ancon manufactures ties in a variety of lengths and types for restraining brickwork, blockwork and stonework. These ties can be fixed to concrete and structural steelwork, as well as any type of masonry.



Masonry Support Systems

Masonry cladding on concrete or steel framed buildings is normally supported by stainless steel masonry support systems. Ancon has developed the most comprehensive range of stainless steel support systems and restraints. Products include AnconOptima, a standard system available from stock. A full design and drawing service accompanies our bespoke support systems.



Tension Systems

The use of tie bars in structures and buildings as an architectural as well as a structural element is increasing. Ancon Tension Systems comprise a range of components which can be supplied in carbon steel or stainless steel in a variety of sizes and finishes. The system looks particularly impressive when used with large areas of glazing or timber trusses.



Shear Load Connectors

Ancon DSD and ESD Shear Load Connectors are used to transfer shear across expansion and contraction joints in concrete. They are more effective than standard dowels at transferring load and allowing movement to take place, and can be used to eliminate double columns at structural movement joints in buildings.



Punching Shear Reinforcement

Used within a slab to provide additional reinforcement around columns, Ancon Shearfix is the ideal solution to the design and construction problems associated with punching shear. The system consists of double-headed studs welded to flat rails, positioned around the column head. The shear load from the slab is transferred through the studs into the column.



Reinforcing Bar Couplers

The use of reinforcing bar couplers can provide significant advantages over lapped joints. Design and construction of the concrete can be simplified and the amount of reinforcement required can be reduced. The Ancon range includes threaded and mechanically bolted couplers.



Masonry Support Systems

Lintels

Masonry Reinforcement

Windposts and Parapet Posts

Wall Ties and Restraint Fixings

Channel and Bolt Fixings

Tension and Compression Systems

Insulated Balcony Connectors

Shear Load Connectors

Punching Shear Reinforcement

Reinforcing Bar Couplers

Reinforcement Continuity Systems

Stainless Steel Fabrications

Flooring and Formed Sections

Refractory Fixings



Ancon Building Products

President Way, President Park
Sheffield S4 7UR
United Kingdom
Tel: +44 (0) 114 275 5224
Fax: +44 (0) 114 276 8543
Email: info@ancon.co.uk
Visit: www.ancon.co.uk
Follow on Twitter: @AnconUK

Ancon (Middle East) FZE

PO Box 17225
Jebel Ali
Dubai
United Arab Emirates
Tel: +971 (0) 4 883 4346
Fax: +971 (0) 4 883 4347
Email: info@ancon.ae
Visit: www.ancon.ae

Ancon Building Products

114 Kurrajong Avenue
Mount Druitt
Sydney
NSW 2770
Australia
Tel: +61 (0) 2 8808 1111
Fax: +61 (0) 2 9675 3390
Email: info@ancon.com.au
Visit: www.ancon.com.au

Ancon (Schweiz) AG

Gewerbezone Widalmi 10
3216 Ried bei Kerzers
Switzerland
Tel: +41 (0) 31 750 3030
Fax: +41 (0) 31 750 3033
Email: info@ancon.ch
Visit: www.ancon.ch

Ancon Building Products GesmbH

Puchgasse 1
A-1220 Vienna
Austria
Tel: +43 (0) 1 259 58 62-0
Fax: +43 (0) 1 259 58 62-40
Email: info@ancon.at
Visit: www.ancon.at

Ancon GmbH

Bartholomäusstrasse 26
90489 Nuremberg
Germany
Tel: +49 (0) 911 955 1234 0
Fax: +49 (0) 911 955 1234 9
Email: info@anconbp.de
Visit: www.anconbp.de

These products are available from:

© Ancon Building Products 2013

The construction applications and details provided in this literature are indicative only. In every case, project working details should be entrusted to appropriately qualified and experienced persons.

Whilst every care has been exercised in the preparation of this document to ensure that any advice, recommendations or information is accurate, no liability or responsibility of any kind is accepted in respect of Ancon Building Products.

With a policy of continuous product development Ancon Building Products reserves the right to modify product design and specification without due notice.



ISO 9001: 2008
FM 12226



ISO 14001: 2004
EMS 505377



OHSAS 18001: 2007
OHS 548992

