

Installation Guide

V 1.2 December 2014 © Amina Technologies Ltd

APU-RS8E

19" Rack Mount, 1U,
Multi-channel Loudspeaker
Protection Unit



Caution: Read before installing this product

- To ensure optimal performance, please read this guide carefully. Keep it in a safe place for future reference.
- Install this product in a cool, dry and clean place - away from direct sunlight, heat sources, vibration, dust and moisture.
- Do not expose this unit to sudden temperature changes or locate it in an environment with high humidity. This is to prevent condensation forming inside which may cause damage to this unit and possibly to devices connected to it.
- Do not clean this unit with chemical solvents as this might damage the finish. Use a clean, dry or damp cloth.
- Do not attempt to modify or repair this unit.
- Contact your distributor or the manufacturer if a fault should occur.
- This unit features internal jumpers that may be adjusted by the installer. Please take care when removing and re-fitting the lid not to damage the four machine screws. Ensure the screws are tight when re-fitting them.

Limited Warranty:

The APU-RS8E is designed to operate reliably for many years. Correctly installed and operated in accordance with these instructions, Amina warranties the APU-RS8E against defective materials and workmanship for a period of 1 year.



The APU-RS8E features only passive circuit components. It should NEVER be connected to the mains electrical supply.

Setting the internal jumpers

The APU-RS8E must be correctly configured for the model of Evolution Series loudspeakers it will be used with.



The APU-RS8E is a low voltage, passive device, however ALWAYS disconnect it from all speakers and amplifiers before adjusting the internal jumpers.

The circuit board inside the APU-RS8E comprises of eight separate audio channels. Each channel features three sets of pins and one connecting jumper.

There is an area on the product serial number label where the individual channel designation can be marked once the jumpers have been set.

Set the jumper for each channel according to the speaker model legend next to each jumper.

Jumper Legend	Compatible Speakers
AIW550E	AIW550E/ AIW550i, AIW450i
AIW350E	AIW350E/ AIW350i, AIW350E-S200, AIW350E-S200, iQ3, AIW250i
AIW150E	AIW150E/ AIW150i, AIW150E-S200, AIW150i-S200, iQ1, iQ2

IMPORTANT: no more than one jumper should be used per bank of 3 pins, e.g.

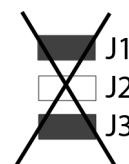

Note: unless specified otherwise jumpers are set for AIW550E/AIW550i as the factory default

Setting the internal jumpers - continued

Inside the APU-RS8E

To set the jumpers the lid of the APU-RS8E must be removed by carefully unscrewing the four machine screws on the sides of the chassis.

The jumpers for each channel are positioned as indicated in the diagram below.

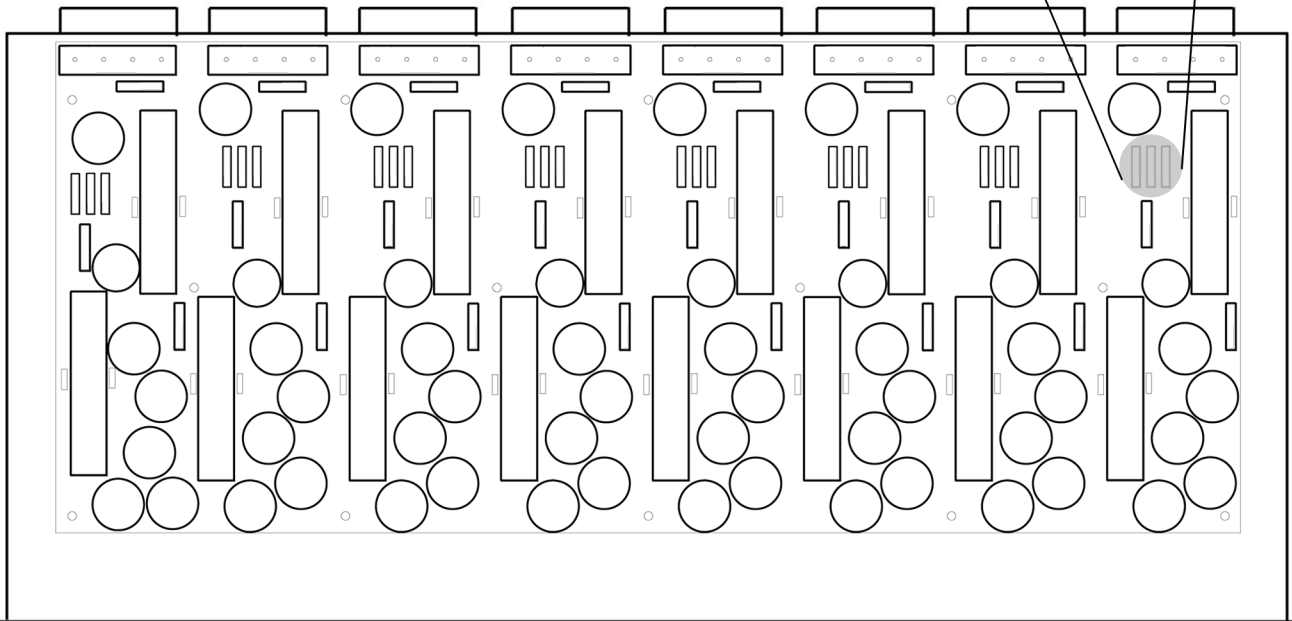
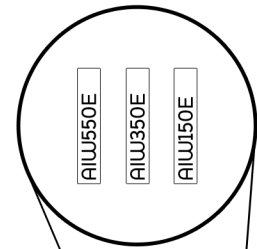

Diagram 1: Internal circuit board layout of APU-RS8E

Important:

Ensure that the jumpers are fully pushed down onto the pins.

Only remove and replace the lid fixing screws by hand. Always use the correct tool and do not over tighten.

Ensure the lid is securely fitted to the product before it is installed.

Mark each channel's fuse setting on the product serial number label for future reference.

Connecting the APU-RS8E

2 Channel example wiring schematic:

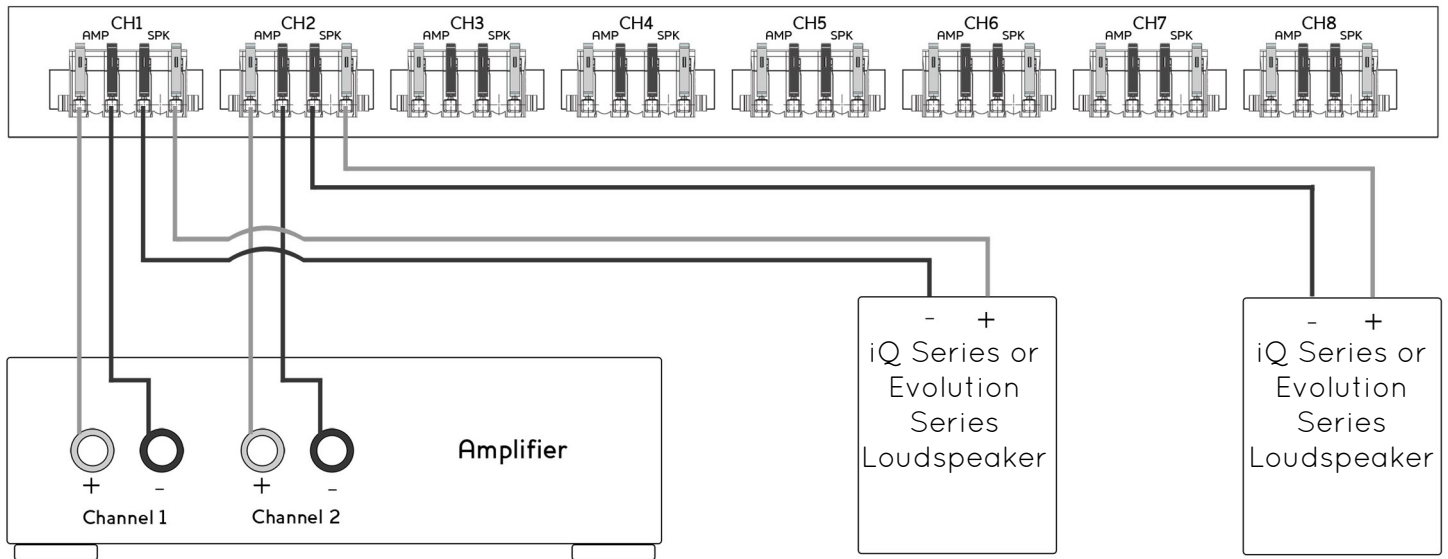
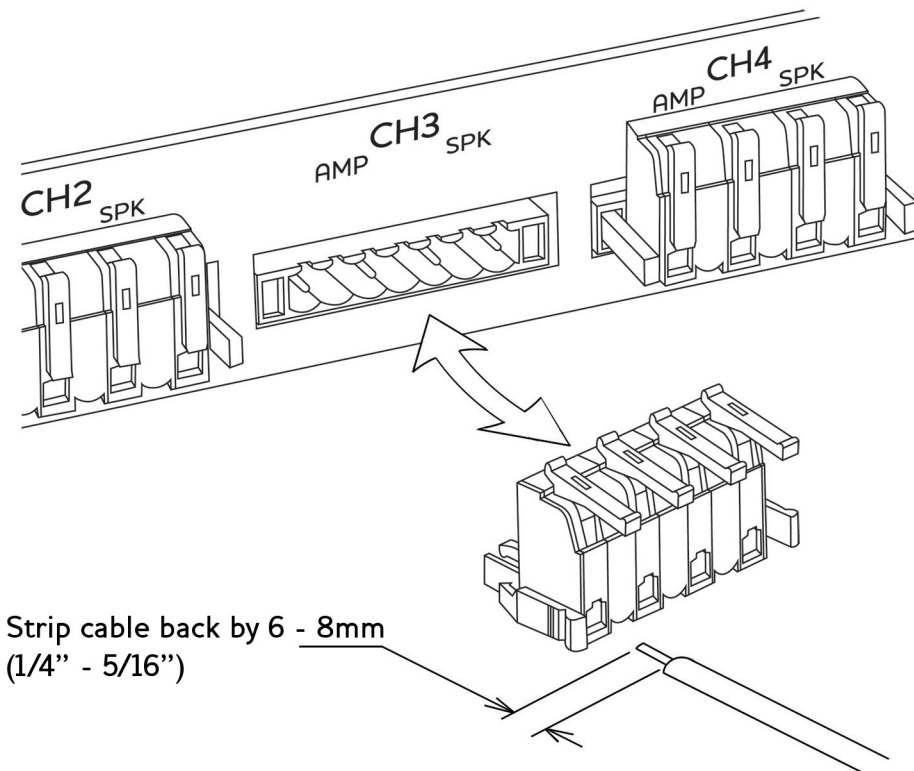

Diagram 2

Note:

In this example the red levers (shown as light grey in the diagram) on the Springcon[®] plugs are used for the “+” loudspeaker connections. Keep the connection polarity consistent on all channels.



Strip cable back by 6 - 8mm
(1/4" - 5/16")

Diagram 3

Note:

Ensure that cables are securely clamped when the Springcon[®] levers are down.

To remove the plugs from the connecting headers press the two clips on either side to release.

Positioning the APU-RS8E

The APU-RS8E is designed to fit into a standard 19 inch equipment rack via 4 mounting holes and has a height of 1U (45mm/1.75 inches).



Diagram 4: APU-RS8E front panel

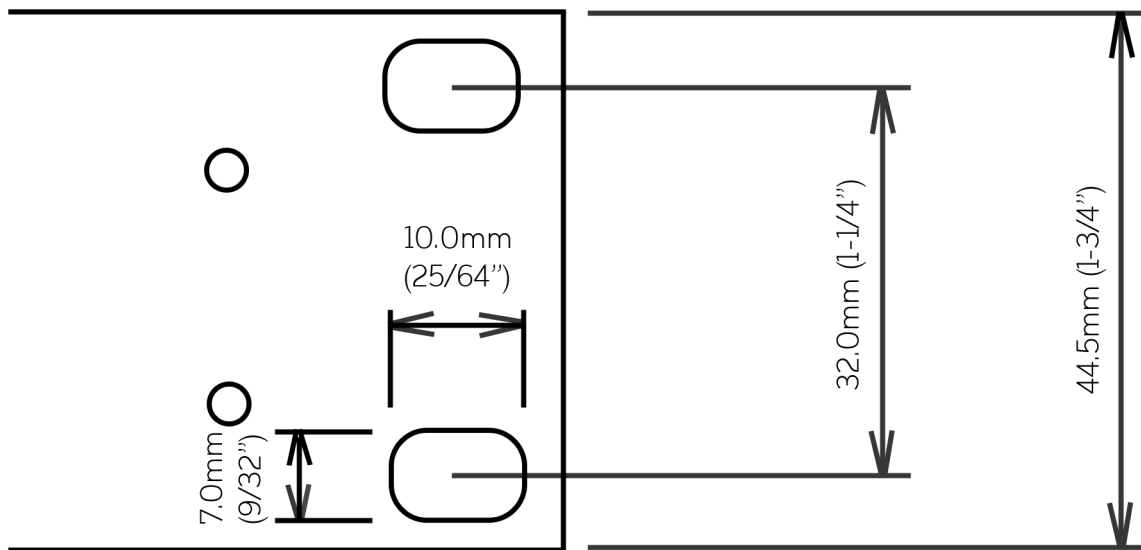

Diagram 5: APU-RS8E fixing points detail

Alternatively, the APU-RS8E can be placed on a shelf. Other equipment (up to 10kg/22lbs) may be placed on top if necessary. Take care not to scratch the top of the case and that any weight is not directly over the centre of the APU-RS8E.

Note:

The APU-RS8E does NOT require ventilation and therefore its installation position is not critical. However, the product should ALWAYS be installed in a dry environment that does not exceed 35 degree Centigrade (95 degree Fahrenheit).

The product's steel case provides all necessary shielding from magnetic fields generated by the APU-RS8E itself (these are very small) or from other equipment placed nearby.

Important information

The APU-RS8E has been designed specifically to enhance the reliability of your Evolution Series loudspeakers. It features a high-pass filter and a current sensing fuse to protect the loudspeaker from being over-driven and potentially damaged. If the APU-RS8E senses excessive drive current from the system's amplifier it will automatically reduce the sound level from the speaker until the amplifier's volume is reduced.

It is important to note the following:

- Ensure that the correct internal jumper setting is used on each channel. Failure to do so could result in speaker damage
- NEVER connect more than one Evolution Series loudspeaker to an output channel
- Be sure that all connections are made in accordance with this guide
- It is not recommended that you use amplifiers with power outputs that are far greater than the loudspeaker's peak power rating
- It is not recommended that you intentionally cause the APU-RS8E to automatically protect the loudspeakers by deliberately over-driving them
- If you find that the APU-RS8E automatically reduces the audio volume from the loudspeakers frequently it may suggest that the amplifier being used is too powerful or that the layer of plaster over the speakers is too thick.



WARNING: DO NOT switch on the amplifier unless both APU-RS8E and Evolution Series loudspeakers are connected to it. Damage may occur to the amplifier if it is operated without a loudspeaker connected to the output of the APU-RS8E.

THE APU-RS8E IS NOT SUITABLE FOR 100V/70V LINE SYSTEMS OR OTHER MANUFACTURER'S LOUDSPEAKERS

Specifications

Dimensions:	1U height front panel, 482mm x 44.4mm (19" x 1.75"), case depth, 213mm (8.375")
Weight:	3.6Kg (8lbs) Nett, 4.2Kg (9.2lbs) Gross
Fuse protection:	Self-resetting, current sensing type. Fuse threshold set via internal jumpers
Compatibility:	Suitable for use with Amina AIW150E/i; AIW150E/i-S200, AIW250i; AIW350E/i; AIW350E/i-S200; AIW450i; AIW550E/i; iQ1; iQ2; iQ3 only
Number of channels:	8
Connection type:	1x Springcon [®] 4 pole connector per channel. Connector carries input and output for each channel
Maintenance requirements:	Protection fuses can be set by installer if necessary. Repeated tripping of fuses may require fuse replacement by the manufacturer to ensure optimal speaker performance



European Union WEEE regulations:

The product is fully RoHS compliant, eliminating to a minimum the use of hazardous materials within its manufacture. At the end of its useful life it should be returned to the manufacturer for recycling according to the European Union's WEEE directive.

All products are subject to change without notification. E&OE

Amina Technologies Ltd
Cirrus House, Glebe Road,
Huntingdon, Cambridgeshire
PE29 7DL, UK

T: +44 1480 354390
E: sales@amina.co.uk
W: www.amina.co.uk