



# EVOLUTION SERIES AIW750i

High Performance  
Invisible Loudspeaker  
Product Data Sheet



- **Completely invisible, high end, 2-way audiophile loudspeaker**
- **Easy to install into cavity walls, solid walls or ceilings**
- **Simply skim over with a finishing coat of plaster or use under other surface materials such as, wood, wood veneer, high pressure laminates, leather, etc**
- **Suitable for high powered audio systems**
- **Features new technologies providing superior bass extension and outstanding mid-range and treble resolution**

The AIW750i Evolution Series loudspeaker takes invisible loudspeakers to a whole new territory with respect to sound quality. When the best sound quality is required the AIW750i will deliver bass, clarity and openness like no other invisible or discrete loudspeaker.

- **OptiDamping technology** delivers **increased low frequency extension and improved mid-range accuracy** by selectively tuning discrete vibrational modes that are generated in the loudspeaker's acoustic panel. The 750i utilises a brand new damping method for improved damping control.
- **OptiDrive technology** optimally distributes the audio signal to the speaker's exciters to **ensure exceptional high frequency clarity on and off-axis**
- **OptiModal technology** employs two separate acoustic panels, each operating over a different, fully optimised frequency range via an onboard passive crossover. This provides **greater bandwidth, clarity and focus** compared to other models within the range. In this case the narrow panel supplies the HF region and the large panel is optimised for the LF region of the entire frequency spectrum

## Specifications

	<b>AIW750i</b>
Nominal impedance	4 Ohms (APU750i connected)
Power handling (continuous/ peak)	100W/ 200W
Sensitivity (2mm plaster/ mud skim)	87dB 1m/ 2.83Vrms (APU750i connected)
Frequency response	50Hz - 20kHz (-6db) mounted in Backbox CV345 and CV200 (APU750i connected)
Electrical connection	Blue butt splice crimp terminals (14-16 AWG), AIW750i HF x1 AIW750i LF x2 (In to out)
Dimensions (LF Panel)	450mm x 345mm x 40mm
Dimensions (HF Panel)	(17 <sup>3/4</sup> " x 13 <sup>5/8</sup> " x 1 <sup>5/8</sup> ")
	450mm x 200mm x 40mm
	(17 <sup>3/4</sup> " x 7 <sup>7/8</sup> " x 1 <sup>5/8</sup> ")
Product weight	HF: 1.4Kg (3.09lbs) LF: 1.5Kg (3.31lbs)
Fixing requirements	Amina BackboxCV345 and CV200 / Back-boxSW345 and CV200 (Wood adhesive and fixing blocks available on request)
In-line protection unit	APU750i
Manufacturer limited warranty for residential applications	10 years

## Cabling Requirements

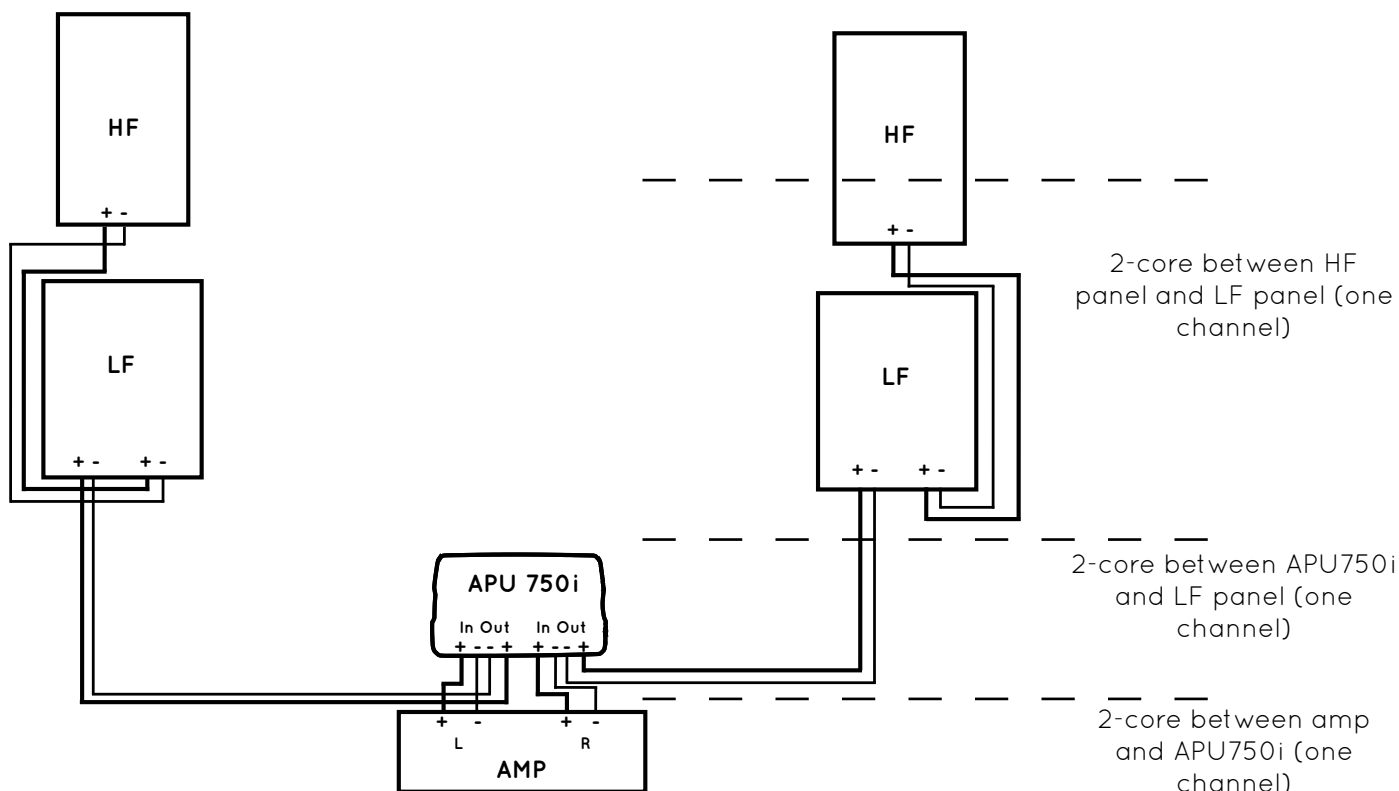

### International

Amina Technologies Ltd  
 Cirrus House, Glebe Road, Huntingdon  
 Cambridgeshire, PE29 7DL, UK  
 T: +44 (0)1480 354390  
 E: inspired@amina.co.uk  
 W: www.aminaco.uk

*amina*<sup>®</sup>  
 TECHNOLOGIES LTD

**EVOLUTION  
 SERIES**

### US

Amina Technologies Ltd  
 P: 1-866 462 6462  
 F: 1-888-329 2491  
 E: sales@aminatechnologies.com  
 W: www.aminaco.uk