



AMBIRAD

Vision

Radiant Tube Heating Systems





Vision



*

Radiant Tube Heating Systems

Renowned for its pioneering track record, AmbiRad, Europe's leading supplier of radiant tube heating systems, has yet again raised the industry standard in terms of innovation and technical performance.

The range of high efficiency Vision radiant tube heaters delivers exceptional performance in terms of efficiency and the potential to reduce energy costs.

VSX models 15% more effective than standard radiant tube heaters, with payback of 6 months achievable when redeeming ECA allowances.

* Applicable to certain models only

Model Range

There are three vision ranges:

- > The high efficiency VSX range, with recuperative heat exchanger, which is available as a 'U' tube model
- > The VS range, complete with stainless steel reflectors and endcaps, is available in 'U' tube, single linear and double linear models and can be mounted in linear or U tube herringbone configurations
- > The VSA range, complete with aluminised reflectors and endcaps, which is available in 'U' tube, single linear and double linear models and can be mounted in linear or 'U' tube herringbone configurations

Features & Benefits

Features:

New advanced burner technology

- > Choice of burner ratings from 15 to 50kW
- > NO_x emissions as low as 52ppm on certain models - 40% lower than standard radiant heater
- > Combustion occurs entirely within the firing tube. Not only does this reduce the size and weight of the traditional burner control housing but it also helps to reduce noise levels (as quiet as 47 dB(A) 3m field)

- > New slim-line burner head provides a long evenly distributed flame that dramatically improves temperature distribution along the entire length of the heater, delivering a more even floor coverage
- > The inclusion of a recuperative heat exchanger on VSX models (patent P308150GB), mounted adjacent to the burner housing, significantly increases thermal efficiencies up to 90% and enhances radiant efficiency above 60%.
- > All units CE approved

Benefits:

Easy to install and maintain

- > On forced gas burner models all electrical wiring is contained at one end of the product, which is particularly time saving when installing single linear (VSLF) heater models
- > All units require straightforward annual maintenance

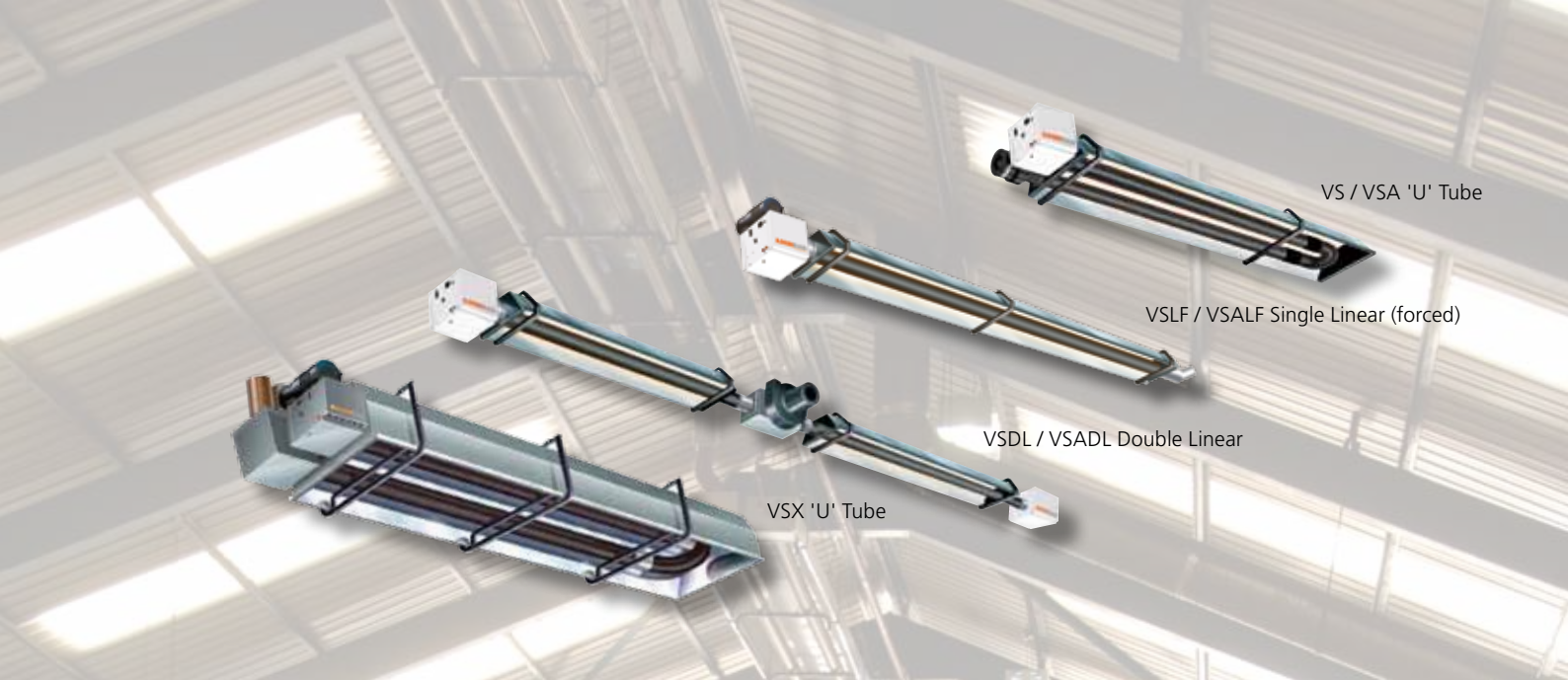

VS / VSA 'U' Tube

VSLF / VSALF Single Linear (forced)

VSDL / VSADL Double Linear

VSX 'U' Tube

Optimum economy and fuel savings

- > The elimination of both distribution and standby losses coupled with high operational efficiencies at the point of use enable fuel savings of up to 65% compared with conventional heating systems
- > Excellent radiant performance. More of the available heat generated is distributed to floor level thereby improving efficiency and reducing energy consumption
- > High efficiency VSX35 & VSX40 are included on the Government's Energy Technology List and may be eligible for Enhanced Capital Allowances (ECA)

Additional control at the touch of a button

All models are compatible with AmbiRad SmartCom control systems. SmartCom units incorporate a host of features such as self learning optimised start-up to ensure



SmartCom³ control panel



Radiant black bulb sensor

(Please refer to separate leaflet 'SmartCom Energy Management Control' for full details)



Herringbone Configuration

Herringbone systems are specifically designed to suit individual building requirements; they can incorporate up to ten 'U' tube or linear heaters on one exhaust manifold. The exhaust manifold may be terminated through the roof or wall

The particular benefits of herringbone systems are:

- > Optimised energy efficiencies
- > All units share a common internal flue thereby raising efficiency within the building

- > Uniform heat distribution within the space being heated
- > Improved aesthetics and minimal risk of water ingress - only one penetration of the building is required to enable the products of combustion to be expelled
- > Universal application - they are ideal for both new build and older premises (in particular where penetration of an asbestos roof is an issue)

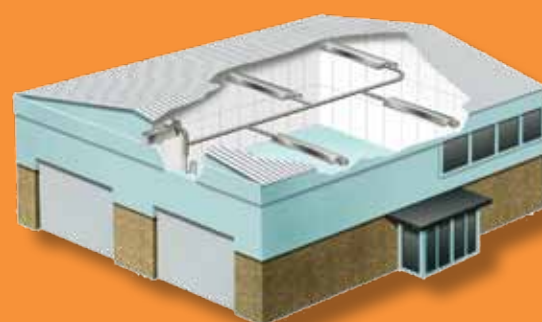

Specification

VSX model

Flueing

Units can be installed unflued or individually flued (including concentric flues to minimise building penetrations).

Fresh air intake

Fresh air can be ducted into the heat exchanger from outside the building to provide clean combustion air, required when there are contaminants in the atmosphere

Burner

Burner ratings range between 20 and 50kW in 5kW increments. The new burner head located within the firing tube leg provides a very long flame with even heat distribution. NO_x emissions are very low - as low as 52ppm on certain models.

Heat Exchanger

Mounted adjacent to the burner housing. Significantly increases thermal efficiencies up to 90% and enhances radiant efficiency above 62.5%.

Control housing

Burner controls are mounted within a chassis that incorporates hinged doors for ease of access for commissioning and maintenance.

Tube finish

CALCOAT® tubes – a high technology process that applies a tough, dense, highly emissive surface both inside and out that eliminates the need for painting. As a result CALCOAT® ensures a long lasting surface that will not rust or flake, protects welds and maintains the highest of emissivity factors throughout the entire life of the heater.

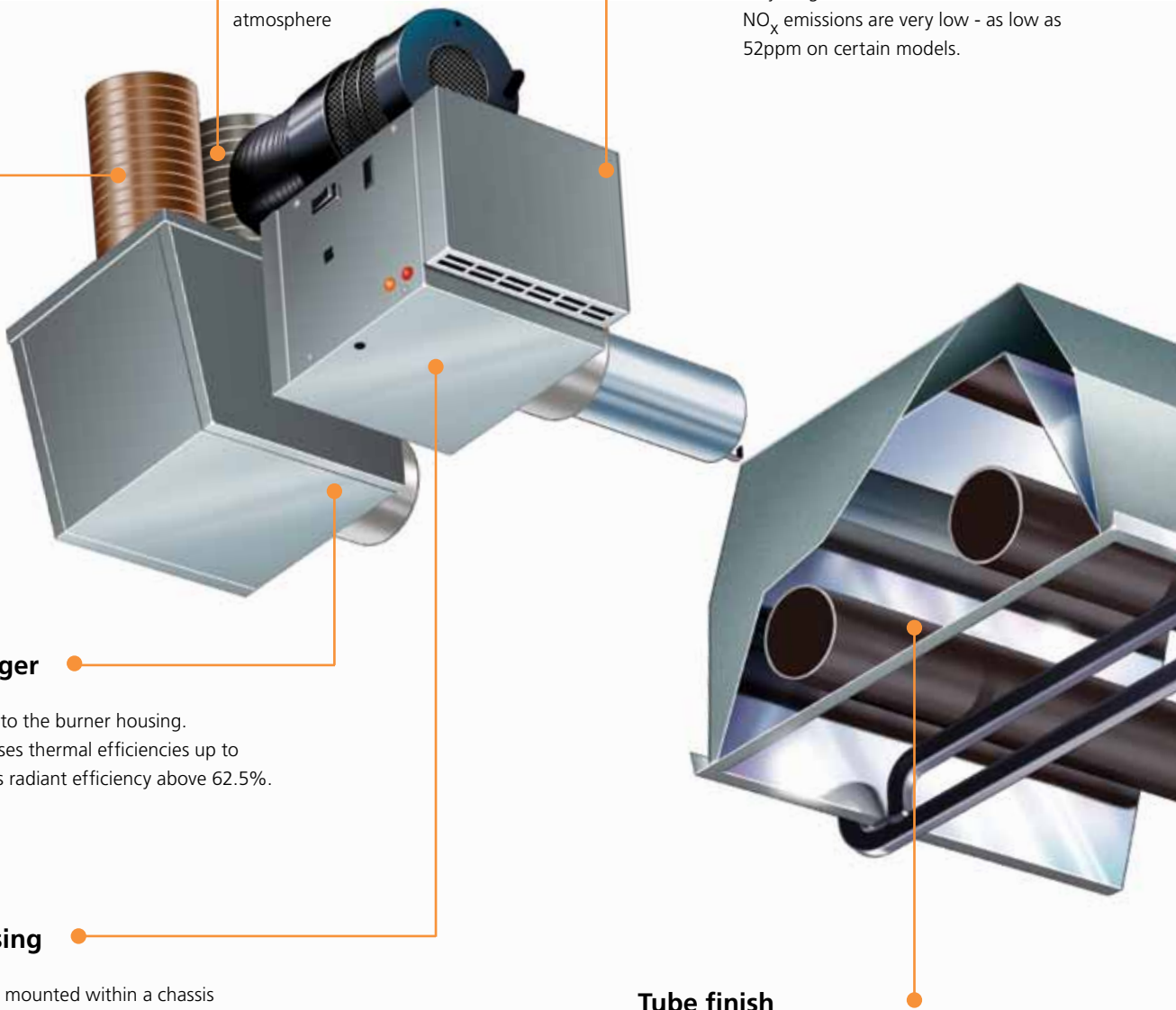

Standard radiant heater

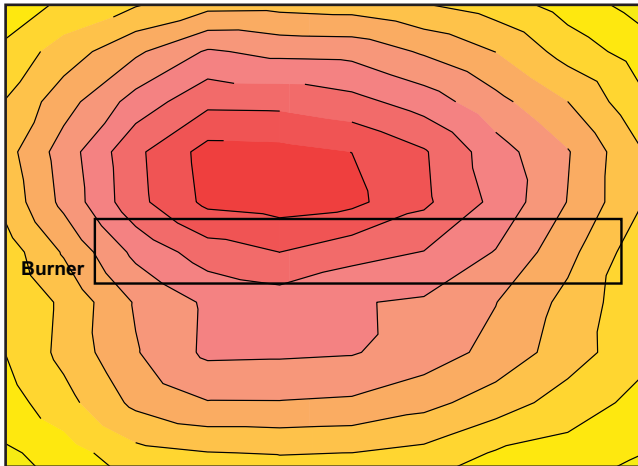

Vision (VSX)

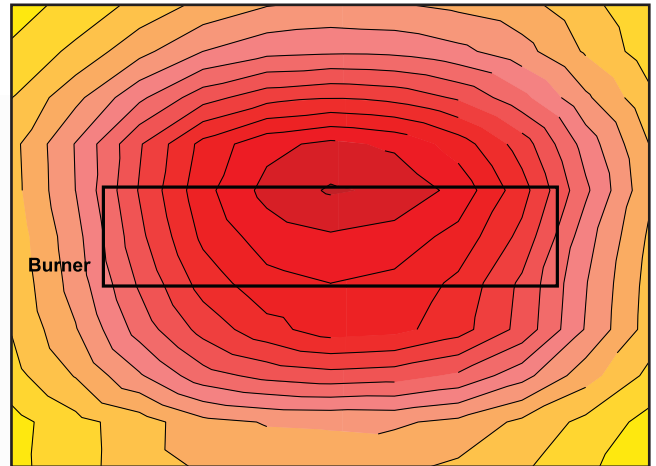

Vision improves temperature distribution along the entire length of the heater.

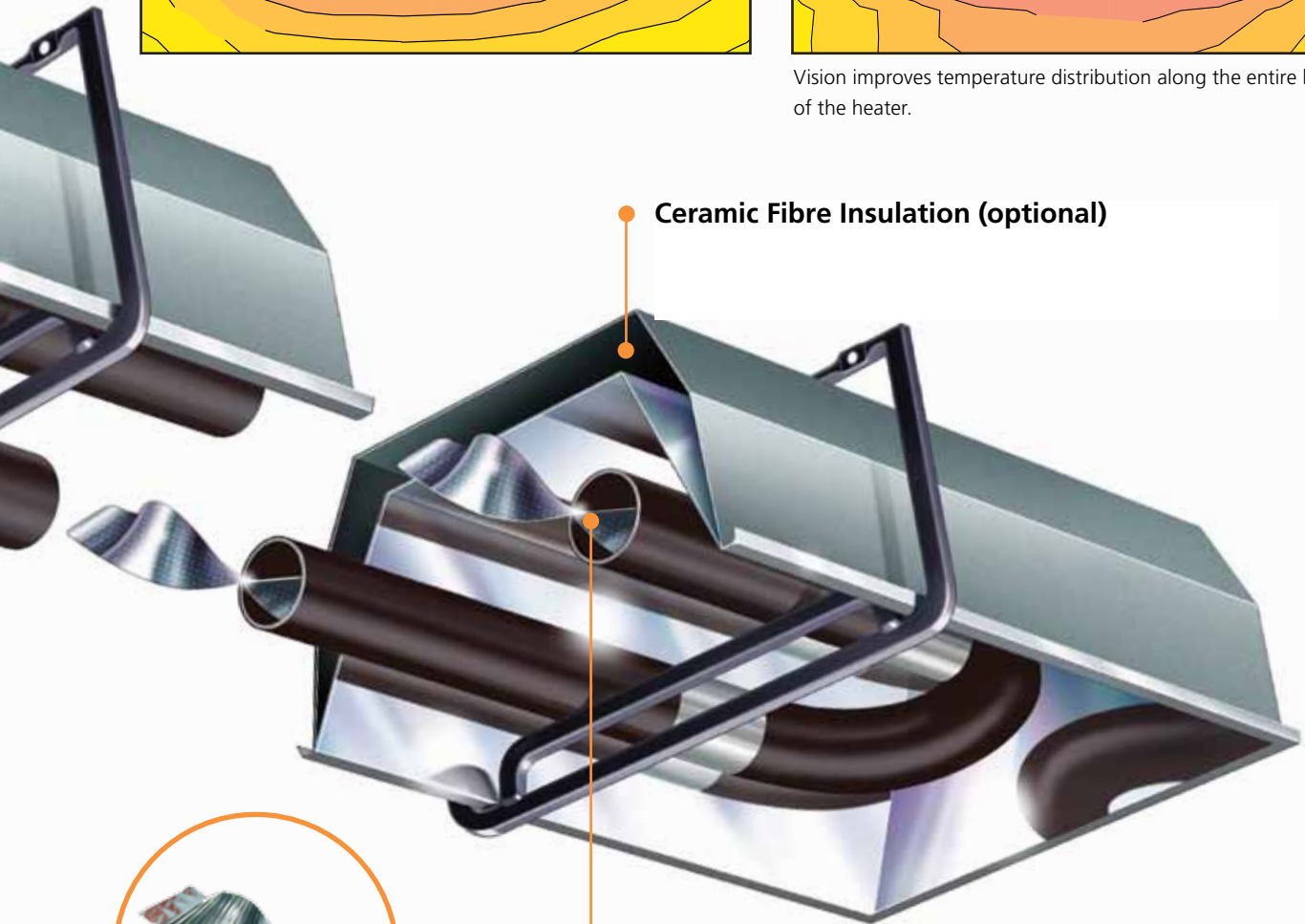

Ceramic Fibre Insulation (optional)

Turbulators

Stainless steel spiral turbulators optimise tube temperatures by 'scrubbing' the flue gases against the tube surface, maximising heat transfer and increasing radiant efficiency.



Radiant Heating

Working in the same way as the sun, radiant heat warms all solid objects and surfaces in its path through electromagnetic waves. Being mounted overhead, AmbiRad radiant heaters produce infrared heat that is directed downwards to low level by a reflector.

Infrared energy passes inertly through the air, dissipating as heat upon contact with people and surfaces thus creating a comfortable, all-round radiant warmth at lower air temperature. This reduces wasteful heating of empty space and makes substantial energy savings over conventional boiler and air systems.

Universal Application

Radiant heating has traditionally been predominant in industrial and commercial buildings, especially where there are large, high bay areas or where there are a high number of air changes within the environment.

Vision has been developed with these markets in mind and with a view to making radiant heating truly competitive within new smaller industrial and commercial buildings.

Its application is universal including environments with high air change, frequently opened doors, or where there is a need for zonal heating in very large premises.

The highly efficient performance of Vision provides greatly reduced running costs and improved capital payback, setting new industry standards.

Vision Applications

- > Aircraft hangars
- > Automotive workshops and showrooms
- > Factories
- > Retail outlets
- > Sports arenas and halls
- > Warehouses
- > Workshops

Enhanced Capital Allowances

The Government's Enhanced Capital Allowance scheme actively encourages industry and commerce to reduce energy consumption by promoting the use of energy efficient equipment. With radiant efficiencies of above 62.5% and thermal efficiencies of up to 91% (reducing fossil fuel consumption) a significant number of Vision models are included on the list.



This symbol verifies that the product has been independently assessed and qualifies for the ECA scheme, an upfront tax relief enabling businesses that invest in energy-saving equipment to claim 100% first-year capital allowances against their taxable profits.



Technical Data - All Models	
Gas supply	Connection 1/2 BSP internal thread
Electrical supply	230 volt 1 phase 50Hz
Current rating	1.0 amp max (inductive)
External fuse rating	3 amp external
Ignition	Electronic programme start up with spark ignition
Exhaust flue - twin wall diameter	127 mm (5")

Vision U Tube Models (induced burner) VSUT & VSAUT

Note: All technical details shown relate to VSUT & VSAUT models except for clearance distances as indicated.

Technical Data											
Model		VS15UT4	VS15UT	VS20UT	VS25UT	VS30UT	VS35UT	VS40UT	VS45UT	VS50UT	
Nominal gross heat input	kW	15.8	15.0	19.5	23.5	29.5	36.0	40.0	44.0	48.0	
Nominal gas rate per burner	m ³ /h	1.5	1.4	1.9	2.3	2.8	3.4	3.8	4.2	4.6	
Dimensional & weight data											
Length	mm	2219	3417	4142	5066	6029	5709	5709	7471	7471	
Overall height	mm	235	168	168	168	168	235	235	235	235	
Overall width	mm	675	500	500	500	500	675	675	675	675	
Total installed weight	kg	41	43	43	60	70	92	92	121	121	
Recommended mounting height range											
For mounting heights above or below those specified contact AmbiRad design office											
Horizontal	m	4 to 5	4 to 5	4.5 to 7	5 to 8	5.5 to 9	6 to 10	6.5 to 11	7 to 12	7.5 to 13	
Inclined / wall mounted	m	3.5 to 4.5	3.5 to 4.5	3.5 to 5	4 to 5	4 to 6	4.5 to 6.5	5 to 7	5.5 to 8	6 to 9	
Minimum Clearance Distances To Combustible Surfaces											
Model		VS15UT4	VS15UT	VS20UT	VS25UT	VS30UT	VS35UT	VS40UT	VS45UT	VS50UT	
Above reflector VS models with end caps	mm	All models 180									
Above burner & fan assembly flued	mm	All models 500									
Beneath tubes	mm	1500			1700			2100			
To the sides	mm	900			1000			1100			
Horizontally from fan outlet unflued	mm	All models 1200									
End of the heater to the wall	mm	All models 500									

Vision Recuperative Heat Exchange U Tube Models (forced burner) VSX

Technical Data										
Model		VSX20UT	VSX25UT	VSX30UT	VSX35UT	VSX40UT	VSX45UT	VSX50UT		
Nominal gross heat input	kW	20.0	25.0	32.0	36.0	40.0	44.0	49.5		
Nominal gas rate per burner	m ³ /h	1.9	2.4	3.1	3.4	3.8	4.2	4.7		
Dimensional & weight data										
Length	mm	4047			5927			7692		
Overall height	mm	All models 450								
Overall width	mm	All models 746								
Total installed weight	kg	114			158			205		
Recommended mounting height range										
For mounting heights above or below those specified contact AmbiRad design office										
Horizontal	m	4.5 to 7	5 to 8	5.5 to 9	6 to 10	6.5 to 11	7 to 12	7.5 to 13		
Inclined / wall mounted	m	3.5 to 5	4 to 5	4 to 6	4.5 to 6.5	5 to 7	5.5 to 8	6 to 9		
MINIMUM CLEARANCE DISTANCES TO COMBUSTIBLE SURFACES										
Above reflector	mm	All models 100								
Above burner & heat exchanger assembly	mm	All models 500								
Beneath tubes	mm	2300			2500					
To the sides	mm	All models 1300								
Horizontally from heat exchanger outlet unflued	mm	All models 1200								
End of the heater to the wall	mm	All models 700								

Vision Linear Models (forced burner) VSLF & VSALF

Note: All technical details shown relate to VSLF & VSALF models except for clearance distances as indicated.

Technical Data									
Model		VS15LF	VS20LF	VS25LF	VS30LF	VS35LF	VS40LF	VS45LF	VS50LF
Nominal gross heat input	kW	13.8	19.5	23.5	29.5	36.5	40.0	45.0	50.0
Nominal gas rate per burner	m ³ /h	1.3	1.9	2.3	2.8	3.5	3.8	4.3	4.8
Dimensional & weight data									
Standard length option	Nominal metres	6	7	8	10.5	10.5	13.5	13.5	13.5
Total installed standard length weight option	kg	43	49	53	72	103	126	126	126
Extended length option	Nominal metres	8	10.5	10.5	12.5	13.5	16	16	16
Total installed extended length weight option	kg	53	72	72	84	126	147	147	147
Overall height	mm	174				235			
Overall Width	mm	304				470			
Recommended mounting height range For mounting heights above or below those specified contact AmbiRad design office									
Horizontal	m	4 to 5	5 to 7	5 to 7	5 to 9	5 to 11	5 to 11	6 to 12	7 to 13
Inclined / wall mounted	m	3.5 to 4.5	4 to 5	4 to 5	4 to 6	4 to 7	4 to 7	5 to 8	6 to 9
Minimum Clearance Distance To Combustible Surfaces									
Above reflector VSLF models with end caps	mm	All models 150							
Above reflector VSLF models no end caps	mm	All models 280							
Above burner	mm	All models 500							
Beneath tubes	mm	1500	1700			2100			
To the sides	mm	All models 750							
Horizontally from heater outlet unflued	mm	All models 1200							
End of the heater to the wall	mm	All models 500							

Vision Linear Tube Models (induced burner) VSLI & VSALI

Note: For all dimensional, weight and clearance details please refer to Vision Linear forced burner section detailed above

Technical Data									
Model		VS15LI	VS20LI	VS25LI	VS30LI	VS35LI	VS40LI	VS45LI	VS50LI
Nominal gross heat input	kW	15.0	19.5	23.5	29.5	36.0	40.0	44.0	50.0
Nominal gas rate per burner	m ³ /h	1.4	1.9	2.3	2.8	3.4	3.8	4.2	4.8

Vision Standard Double Linear Models (induced burner) VSDL & VSADL

Note: For clearance details please refer to Vision Linear forced burner section detailed above

Technical Data									
Model		VS15DL	VS20DL	VS25DL	VS30DL	VS35DL	VS40DL	VS45DL	VS50DL
Total nominal gross heat input both burners	kW	30.0	39.0	47.0	59.0	72.0	80.0	88.0	100.0
Total nominal gas rate both burners	m ³ /h	2.8	3.8	4.6	5.6	6.8	7.6	8.4	9.6
Dimensional & weight data									
Standard length option	Nominal metres	12	14	16	21	21	27	27	27
Total installed standard length weight option	kg	86	98	106	144	206	252	252	252
Extended length option	Nominal metres	16	21	21	25	27	32	32	32
Total installed extended length weight option	kg	106	144	144	168	252	294	294	294

Document reference number: GBA/S/191/0613

AMBIRAD LIMITED
Fens Pool Avenue
Brierley Hill
West Midlands DY5 1QA
United Kingdom

Tel: 01384 489 700
Fax: 01384 489 707

ambiradsales@nordyne.com
www.ambirad.co.uk



AMBIRAD AIRBLOC NORDAIRNICHE BENSON