



BENSON

ULTRA

Condensing Gas Fired Unit Heaters

AMBIRAD
HEATING AND VENTILATION SOLUTIONS





ULTRA

Condensing Gas Fired Unit Heaters

Benson continue their tradition of manufacturing high efficiency warm air heating equipment with the introduction of the new high efficient ULTRA series of energy saving condensing gas fired unit heaters.

The ULTRA range provides the highest efficiency levels and substantially reduced CO, CO₂ & NO_x emissions (under 25ppm).

The units exceed the requirements of current Building Regulations L2, with thermal efficiencies up to 109% to provide exceptional levels of seasonal efficiency. Also the extremely low NO_x emissions enable BREEAM points to claimed (when applicable).

These 4th generation units utilise tubular primary heat exchanger and a secondary condensing heat exchanger with an aerodynamic profile and 4-pass flue gas circuit.

Model Range

The ULTRA condensing units consisting of five models is available with heat outputs ranging from 25kW to 95kW for use on natural gas or propane.

Features & Benefits

- > Thermal efficiency of 99% at full load and up to 109% at minimum load for lower operational costs
- > Substantially reduced CO, CO₂ and NO_x emissions (under 25 ppm) considerably lower than the emissions of the previous generation of unit heaters, and already exceeding European standards
- > Reduced energy bills
- > Ideal for new low carbon buildings
- > Up to 35% energy saving on replacement heaters
- > Burner with new "pull through" combustion technology. Negative pressure ensures that no gas or flue gas can escape into the heated space
- > Versatile flue options (top or rear connections) for ease of installation
- > High flow axial fan for a powerful air throw, decreases stratification and improves heat distribution
- > 5:1 turn down ratio for close temperature control. Reduced temperature gradients help prevent stratification

Advanced Heat Exchanger Technology

Superior heat exchanger using patented MacroChannel multipass heat exchanger technology offers optimum heat transfer.

As the flue gases pass through the heat exchanger the extra surface area and high thermal conductivity of the aluminium MacroChannel (many times greater than steel) cools the flue gases below 45°C causing the water vapour to condense and release its latent heat.

This heat, which would normally be lost to the atmosphere via the flue, is instead transferred into the building hence less fuel is used to achieve the same heat output.

The high efficiency levels are not dependent on the firing rate and the units are permanently condensing, with constant low flue gas temperatures.

This results in far lower energy consumption and carbon emissions compared to other types of condensing units which only achieve comparable efficiency levels at reduced heat outputs.

Optimum Economy and Fuel Savings

In times of rapidly increasing energy costs, reducing energy consumption makes sense both financially and environmentally since this also significantly reduces CO₂ emissions.

Although condensing air heaters require a higher initial capital investment they are very economical and can repay the extra initial cost in fuel savings in 2-4 years depending on usage.

When replacing traditional units more than 10 years old, savings of 30% can be achieved.

Applications

- > Automotive workshops
- > Factories
- > Retail outlets
- > Sports facilities and halls
- > Warehouses
- > Workshops

Comparative Energy Consumption

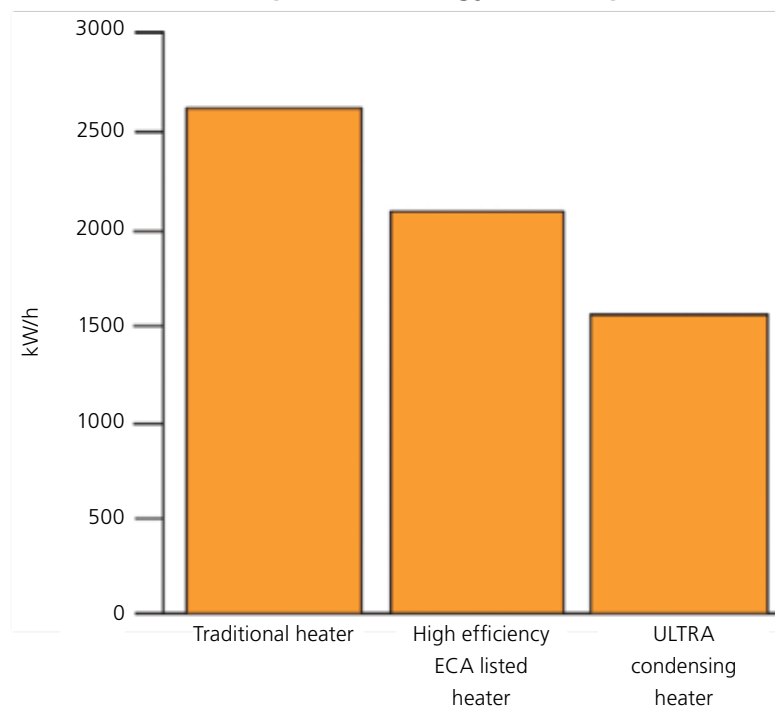

Enhanced Capital Allowances

The Government's Enhanced Capital Allowance scheme actively encourages industry and commerce to reduce energy consumption by promoting the use of energy efficient equipment. The high thermal efficiency of ULTRA units (up to 109%), significantly exceeds the 101% threshold for Enhanced Capital Allowances.

This symbol verifies that the product has been independently assessed and qualifies for the ECA scheme, an upfront tax relief enabling businesses that invest in energy-saving equipment to claim 100% first-year capital allowances against their taxable profits.



BENSON

Condensing Gas Fired Unit Heaters

Primary Heat Exchanger

Manufactured from high quality corrosion resistant steel, the entirely new primary heat exchanger reduces thermal stress for enhanced life expectancy.

This tubular heat exchanger is welded to the burner box using the newest robotic welding technology to form a highly resistant and durable assembly.

Secondary Heat Exchanger

The secondary heat exchanger, made from titanium stabilised alumised steel, or optional stainless steel is constructed weld-free. This heat exchanger constitutes the second part of the flue gases which condenses in a 4-pass circuit in order to release their latent heat.

The streamlined aerodynamic profile of the secondary heat exchanger results in minimal resistance to airflow to give longer throws and improved air distribution, which reduces energy consumption.

Originally, used as a primary heat exchanger in other Benson unit heaters, this proven design is now integrated into the ULTRA's new assembly as a secondary heat exchanger.

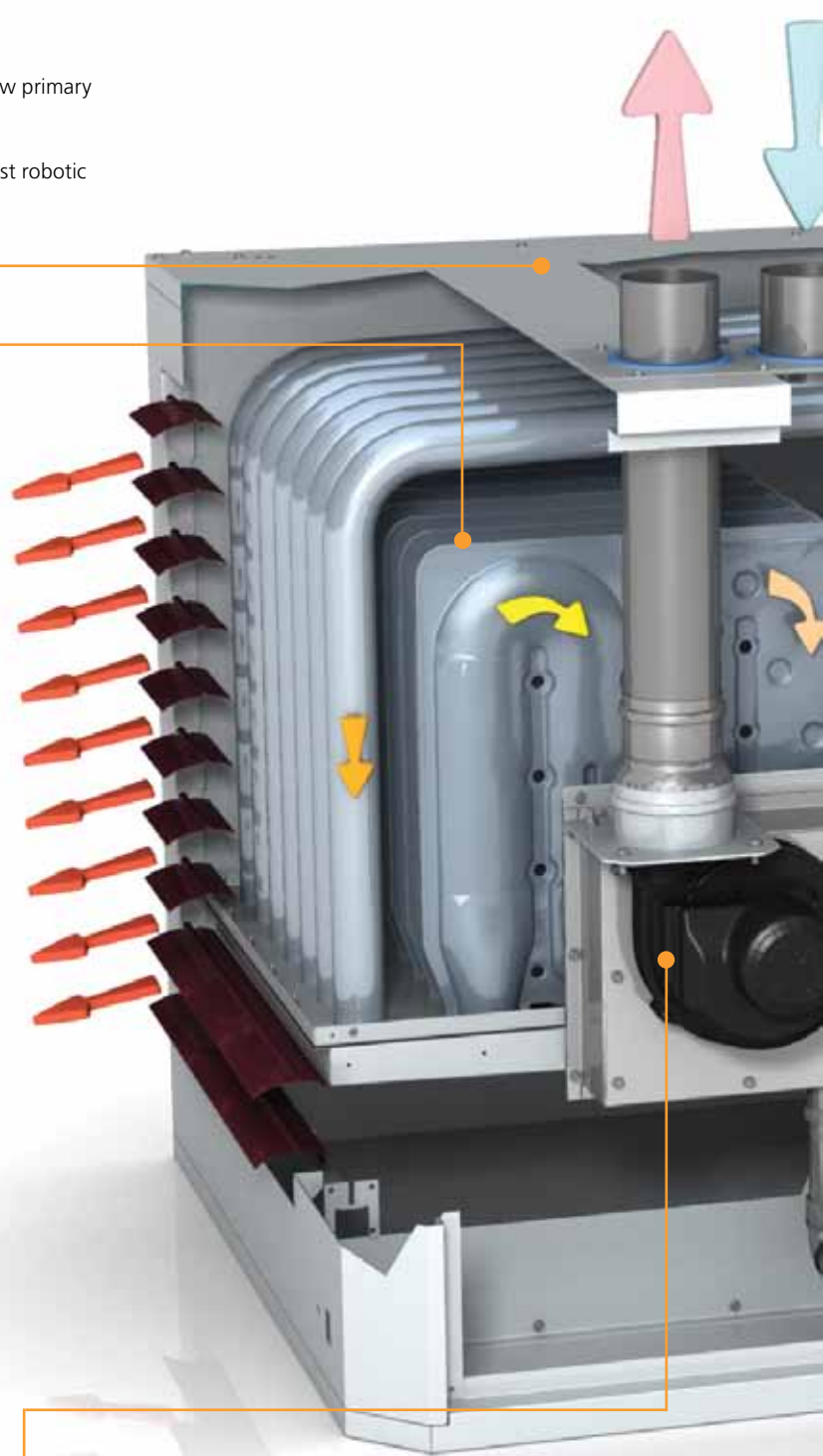

Traditional unit heater

Higher roof space temperatures increase heat loss through roof

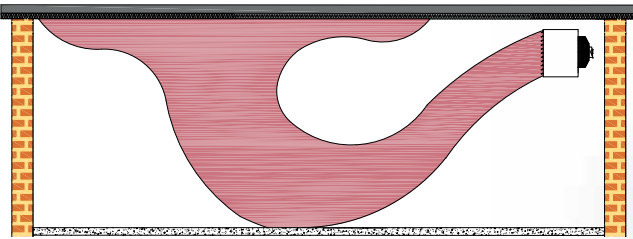

Shorter air throws reduce air distribution efficiency and require longer pre-heat times

ULTRA heater

Reduced floor to ceiling temperature gradients

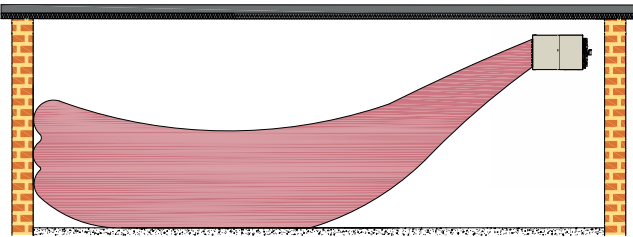

Longer air throws provide even heat distribution and reduce pre-heat times

Venter fan

The flue fan provides a negative pressure that ensures that gases can not escape and can only be exhausted through the flue system. The aluminium corrosion resistant flue fan is housed in a separate compartment.

Units are fully room sealed to prevent dirt or dust from entering the combustion system. A differential pressure switch shuts down the unit in the vent of inadequate air, blocked flue or flue fan failure



Air Distribution

A high capacity axial flow fan is fitted to all units for improved air throws and reduced stratification.

The fan operation is controlled by an integral controller which delays the fan start up until the heat exchanger has reached operating temperature and continues to run the fan after the burner has switched off until all useful heat has been dissipated.

An optional economy thermostat may be fitted to heaters installed at high level to recirculate warm air down to working level when the burner is switched off.

Controls

To further maximise efficiency, the ULTRA unit is equipped with integrated controls that allow 5:1 modulation. The reduced temperature gradients will prevent stratification.

Electrical Components

All electrical components are accessible from one side of the unit heater through a full width hinged door. The electrical components are housed in the same compartment as the flue fan in order to facilitate installation and service.

Condensate Drain

All units are supplied complete with condensate trap (loose) and condensate drain point to the heater and the flue.

Burner

Advanced single burner, with multi-try ignition for and ease of maintenance and optimum reliability. This clean pre-mix burner technology guarantees very low emissions.

Installation

Units may be suspended or alternatively mounted on a suitable non-combustible support. Four integral suspension points complete with an M10 female thread are provided to each heater.

The balanced flue terminal provides both the combustion air inlet and flue outlet from a single building penetration. The terminals are ordered separately from the heaters to suit either a wall or roof outlet. Additional flue and combustion air pipes may be added, up to a maximum of nine metres of flue pipe, plus nine metres of combustion air pipe. (This reduces by 1.5 metres for every 90° bend fitted.)

To comply with CE approvals, balanced flue appliances must be used with the manufacturer's balanced flue system. The units are also certified for fan assisted flue installations, where the combustion air is to be drawn from within the heated space; an alternative wall or roof terminal is required for this application.

A single phase electrical supply is required to each unit. This supply should not be switched off except for maintenance.

Units must not be installed in atmospheres containing highly flammable or explosive vapours, combustible dust, halogenated hydrocarbons or chlorinated vapours. They are also unsuitable for areas where contaminants may affect electrical motors or connections.

A condensate drain must be installed in accordance with local regulations. Condensate traps are supplied with each heater, additional pipework must be supplied by the installer.

Enhanced Reliability and Safety

A microprocessor burner control provides full safety monitoring and multi-try ignition control for enhanced reliability.

Limit stats monitor the operating temperature within the heater unit and shut down the burner in the event of overheating. For additional safety all models are fitted with dual limit stats.

A differential pressure switch shuts down the unit in the event of inadequate combustion air, blocked flue or flue fan failure.

Ease of Maintenance

All controls are accessible from a single side and are housed behind a hinged door, situated on the left hand side of the unit when viewed from the rear. The hot gas exhaust fan is housed in a separate adjacent compartment.

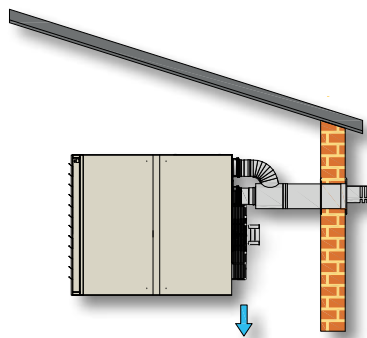

Condensate Drain Required

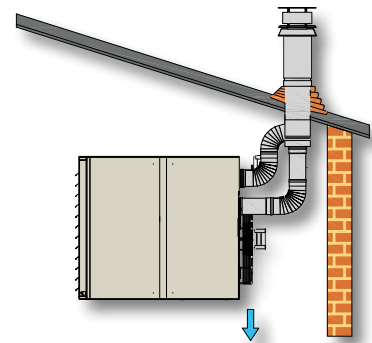

Condensate Drain Required

Balanced flue wall outlet (type C12) eliminates expensive roof opening and flashing

Balanced flue roof outlet (type C32)

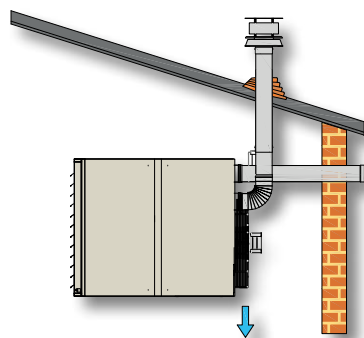

Condensate Drain Required

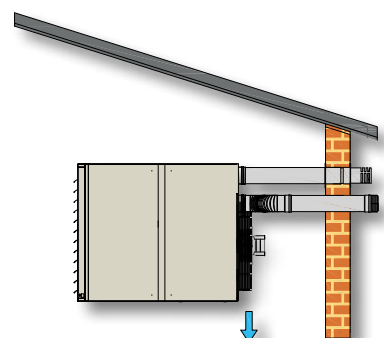

Condensate Drain Required

Combustion air through wall, flue outlet through the roof (C52)

Separate combustion air and flue pipes (type C12) for applications where wall thickness exceeds maximum length shown in flue dimension table

Heater positions and flue arrangements are indicative. For heater and flue clearances please refer to our sales leaflets.

SmartCom

Environmental issues dictate that buildings need to operate as effectively and efficiently as possible. Initiatives such as the Climate Change Levy and the subsequent introduction of the Government's Energy Technology List (ECA scheme), together with upgrading Part L of the Building Regulations, have resulted in consulting engineers, contractors and end users becoming increasingly energy conscious.

Benson SmartCom, the intelligent energy management controller satisfies the growing need for higher efficiencies and to complement the development of energy efficient heating systems.

Simple to program and operate, SmartCom³ provides cost-effective energy management for small single heater installations through to large multi-zone applications requiring centralised control.

Touch of a Button

To complement the high efficiency ULTRA units a versatile range of SmartCom control panels are available.

- > Self-adapting optimum start and stop
- > Simple user-friendly programming
- > Individual seven day programming
- > Day, night and frost (5°C) temperature settings
- > Three on/off periods per day
- > Easy set overtime and holiday periods
- > Remote burner reset facility
- > Password protection to prevent unauthorised adjustment
- > Hours run and service data logging
- > Battery back up in the event of mains failure
- > High / low or modulating burner control (Multi-zone version req

Multi-zone Control

Allows up to 16 units to be centrally controlled. Functions controlled by the master unit include:

- > Clock updating
- > Updating temperature functions and programme settings
- > Viewing the current temperature and target
- > Setting holiday, overtime and vent only functions for the entire network
- > Centralised burner lock out reset



TECHNICAL DATA				Model				
				ULSA 25	ULSA 35	ULSA 50	ULSA 75	ULSA 100
Nominal heat input		kW		25.0	32.7	49.7	69.6	94.4
Maximum thermal efficiency at minimum heat input		%		109.2	108.8	108.7	106.5	108.9
Airflow		m ³ /h		2900	3700	5600	7900	10500
Temperature rise		°C		25.3	25.7	25.9	25.7	26.2
Throw ¹		m		20	23	30	30	36
Noise level (free field @ 5m)		dB(A)		47	51	55	53	58
Gas Consumption ²	Natural gas G20	m ³ /h		2.59	3.39	5.07	7.27	9.76
	Propane G31	kg/h		1.99	2.60	3.93	5.51	7.47
Gas connection ³		Rc		½"	½"	¾"	¾"	¾"
Mounting height ⁴		m		3	3.5	3.5	4	4
Total electrical load		kW		0.29	0.32	0.69	0.75	1.25
Net weight		kg		112	129	141	197	243

1 Throw is dependent on mounting height, building height, room temperature and louvre settings.

2 Natural gas G20 Calorific value 10.48kW/m³ GCV, inlet gas pressure maximum 50mbar, minimum 17.5mbar.
Propane G31 Calorific value 14.0kW/kg GCV, inlet gas pressure maximum 50mbar, minimum 37mbar.

3 Not supply line size.

4 Recommended height to underside of heater for standard horizontal discharge units. Downturn nozzles are recommended for units installed at higher mounting heights. For buildings over 4 metres high, air re-circulation fans are recommended in conjunction with the heaters.

DIMENSIONS

		Model				
		ULSA 25	ULSA 35	ULSA 50	ULSA 75	ULSA 100
Unit height	A	885	885	885	885	885
Unit length	B	1207	1207	1214	1214	1214
Unit width	C	738	738	865	1177	1433
Base to gas inlet	D	222	222	222	222	222
Top to air inlet	E	231	231	231	203	203
Top to flue outlet	F	351	351	351	343	343
Side to air inlet and flue outlet	G	135	135	140	143	143
Flue and combustion air collars	Ø mm	80	80	80	100	100
Suspension centres	H	449	449	576	860	1144
	I	760	760	760	760	760
	J	105	105	105	105	105
	K	55	55	50	78	50
Top clearance		100	100	100	100	100
Rear clearance		400	400	400	500	500
Bottom clearance*		100	100	100	100	100
Side clearance		100	100	100	100	100
Service panel clearance		820	820	820	820	820

*Heaters may be base mounted directly onto non-combustible supports adequately sized to support the unit weight

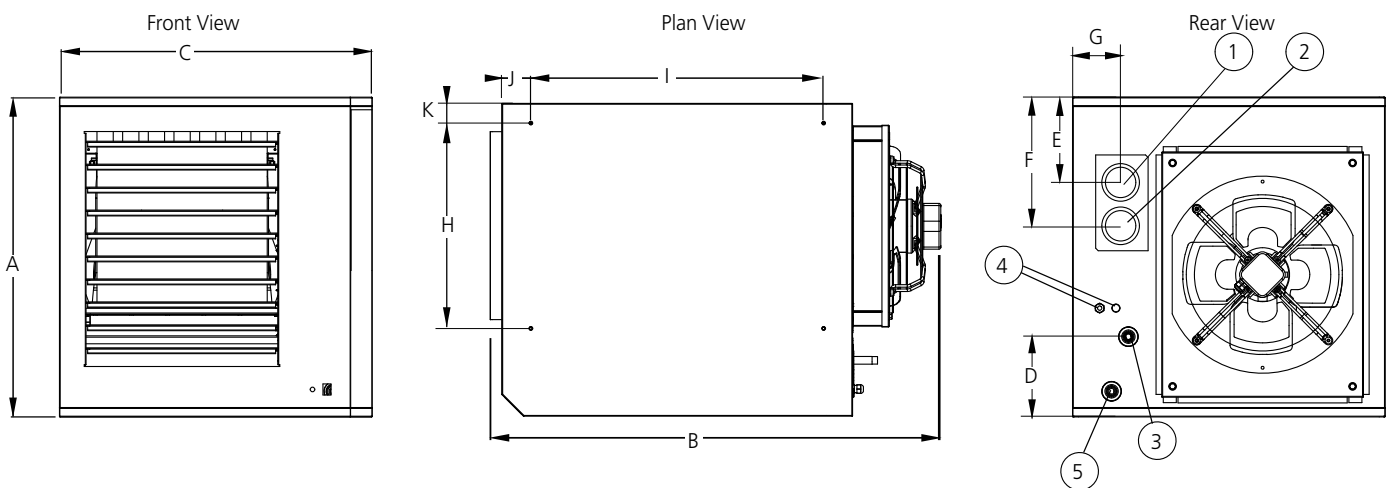

1. Combustion air inlet
2. Flue connection
3. External Gas Connection
4. Electrical connections
5. Condensate drain dia 32mm female

GB/BEN/020/1113

AMBIRAD LIMITED

Fens Pool Avenue
Brierley Hill
West Midlands DY5 1QA
United Kingdom

Tel: 01384 489 700

Fax: 01384 489 707

ambiradsales@nordyne.com

www.ambirad.co.uk



AMBIRAD AIRBLOC NORDAIRNICHE BENSON