



# BENSON

---

## DS Series

De-stratification Fans

---



**AMBIRAD**  
HEATING AND VENTILATION SOLUTIONS



# DS Series

## De-Stratification Fans

With any conventional air heating system warm air will rise to roof level by natural convection. In high buildings such as factories, warehouses and sports centres, this can result in high temperature gradients and consequently increased energy usage.

Benson de-stratification fans reverse the natural convection process, re-circulating warm air back to working level providing a permanent reduction in roof space temperature and uniform temperature distribution.

### Model Range

De-strat fans are available in five sizes, with mounting heights ranging from 4m to 18m and air volumes from 3,000 m<sup>3</sup>/h up to 11,000 m<sup>3</sup>/h.

DS units are supplied with a high efficiency axial fan with mesh finger guard, robust double skin cabinet with four point suspension and four way discharge with adjustable louvers.

Frost protection unit excluding integral thermostat also available.

## Features

- > Heat recovery by re-circulating high level hot air back to occupancy level
- > Reduced fuel bills by eliminating excess heat loss through the roof
- > Heat reclaim from lighting and machinery
- > Improved comfort level for occupants
- > Reduced pre-heat time

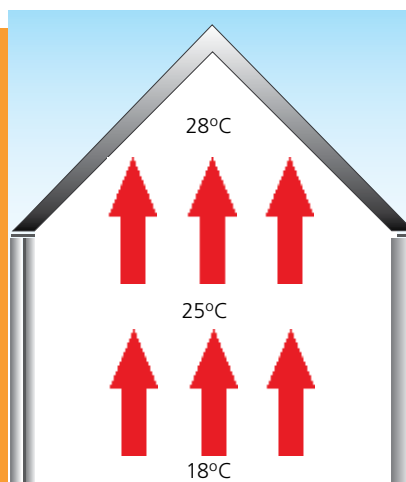

Without de-stratification heat rises resulting in poor distribution, increased heat loss and running costs.



The DS fan returns heat to the working zone for improved comfort and reduced running costs.

### Potential savings by reducing excess of heating stratification

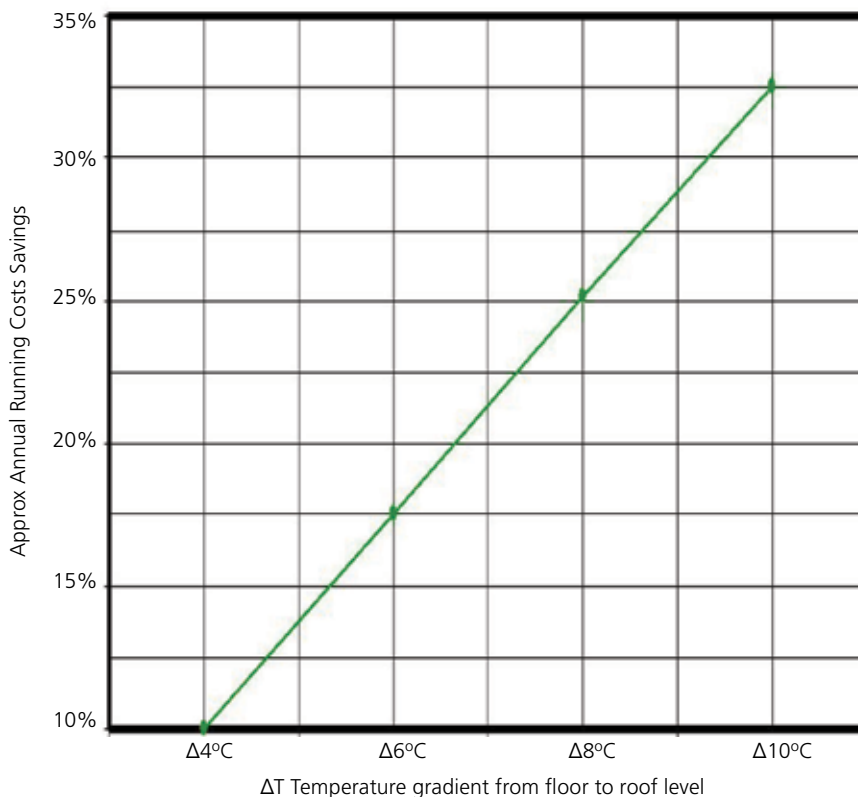

For effective de-stratification, sufficient fans must be installed to re-cycle heat from the full roof area.

### Installation

DS units are supplied ready for automatic operation with installation only requiring mounting and connection to a single phase electrical supply.

Standard units are supplied with an integral thermostat to operate the fan as soon as the roof space temperature rises above the set point.

For frost protection applications units are supplied without thermostats to be linked to frost protection controls.

The four-way adjustable outlet blades allow the air direction and terminal velocity to be set to suit the application and mounting height.

### Design Data

Select the DS unit to suit the mounting height required, ideally the units should be installed approximately 1 metre below the apex.

Calculate the volume of the building and multiply by two to determine the amount of air that needs to be re-circulated for effective de-stratification. Divide by the primary air volume of the unit to determine the number of units required.

### Technical Data

		Model Ref				
		DS3	DS4	DS6	DS8	DS10
Mounting height	m	4 - 8	6 - 12	6 - 12	10 - 18	10 - 18
Approx mounting centres <sup>1</sup>	m	13 - 16	15 - 20	15 - 20	16 - 21	17 - 23
Air volume	m <sup>3</sup> /h c.f.m	3000 1765	4250 2500	6500 3826	7650 4500	11000 6475
Maximum throw	m	8	12	12	18	18
Velocity	m/s	3.77	3.63	4.72	6.53	5.73
Electrical supply		230V 50Hz 1Pha				
Motor size	W	160	230	245	600	725
Operating current	A	0.7	0.8	1.1	2.0	3.5
Starting current	A	1.5	1.9	2.4	6	6.7
Fuse rating	A	6	6	6	10	10
Thermostatic control		Included				
Sound pressure level <sup>2</sup>	Lp dB(A)	51	54	56	62	65
Net weight	kg	15	23	20	23	30

<sup>1</sup> Mounting centres depend on mounting height

<sup>2</sup> Sound level @ 4m

## Dimensions

Model Ref	DS3	DS4/DS6/DS8	DS10
A	470	570	720
B	470	570	720
C	358	370	602
D	358	370	462
E	300	400	400
F	200	260	260

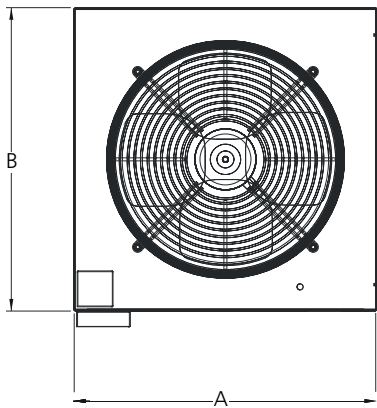

Top view

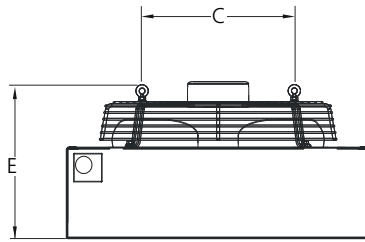

Side view

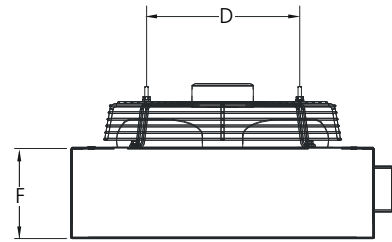

Front view

## Wiring Details

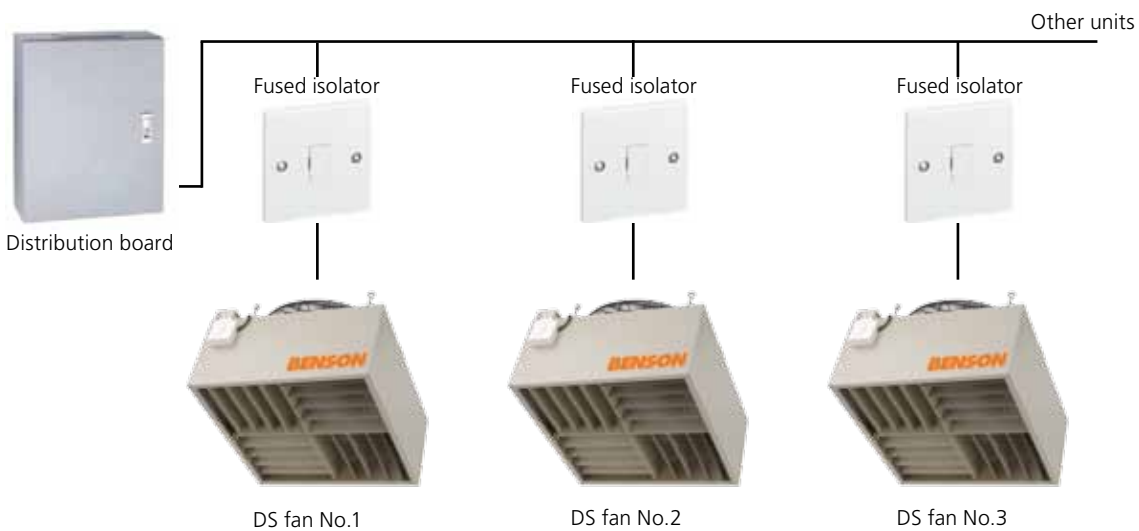

Document reference number: GB/BEN/013/0213

### AMBIRAD LIMITED

Fens Pool Avenue  
Brierley Hill  
West Midlands DY5 1QA  
United Kingdom

Tel: 01384 489 700  
Fax: 01384 489 707

ambiradsales@nordyne.com  
www.ambiradgroup.co.uk



**AMBIRAD AIRBLOC NORDAIRNICHE BENSON**