

Universal user module, PLURIMOD

Centralised domestic water CONTECA heat metering



7000 series



BS EN ISO 9001:2008
Cert. n° FM 21654



UNI EN ISO 9001:2000
Cert. n° 0003



Specifications

Current regulations and provisions regarding the design of centralised domestic water/heating systems require the application of user modules.

The user module (independent flame-free mini-boiler) offers independent heating control and therefore keeps a record of direct consumption data, both in terms of thermie/refrigeration units and domestic hot/cold water.

The user module incorporates multiple hydraulic solutions which can be actuated directly on-site.

- **Three-way zone valve**, equipped with by-pass setting.
- **Two-way zone valve** (by-pass in closed position).
- Vertical or horizontal positioning with left side or right side connection.
- AUTOFLOW® arrangement.
- Possibility for aggregation of 3 domestic water outlets.

Standard functions

- On/off zone regulation
- Heat metering in conformity with directive 2004/22/EC (MID) with arrangement for centralised transmission.
- Insulation.

Optional functions

- Possibility for aggregation of 3 domestic water outlets (DHW, DCW and any dual water).
- AUTOFLOW® automatic flow rate regulator.
- Mix function with mechanical thermostatic mixing valve 5217 series.

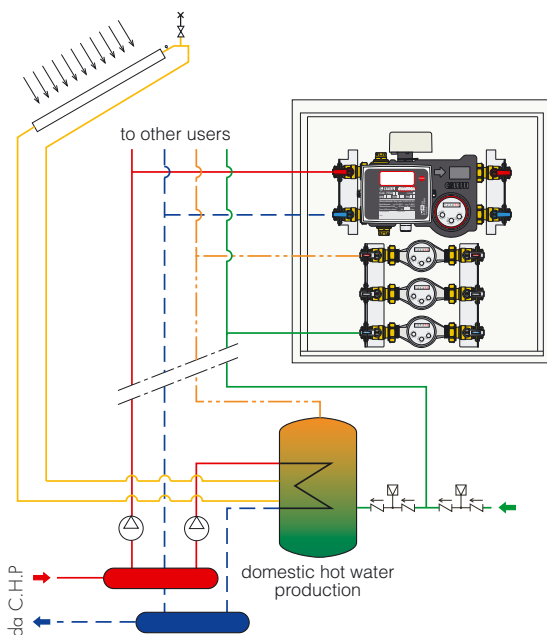

Technical specifications

Materials

Components: brass EN 12165 CW617N; CW614N; CW602N
Connecting pipes: copper

Performance

Max. working pressure: 10 bar
Temperature range: 3–90°C
Medium: water, glycol solutions
Maximum percentage of glycol: 30%
Connections: 3/4" M

Insulation

Material: semi-rigid expanded polyurethane
Temperature range: 0–90°C
Reaction to fire (DIN 4102): class B2

Characteristic components

- 520x520 galvanised plate box adjustable depth between 110 and 150 mm
- door made of painted plate **for interiors** (RAL 9010)
- actuator, 6440 series
- one-piece zone valve
- bracket template with 2 pairs of ball shut-off valves and flushing pipes
- CONTECA heat meter, 7554 series
- template for positioning of triple-function domestic water outlet, 700050/700051 series
- meter template connection point.

PLURIMOD hydraulic module - code 70015-70016

Fig. 1

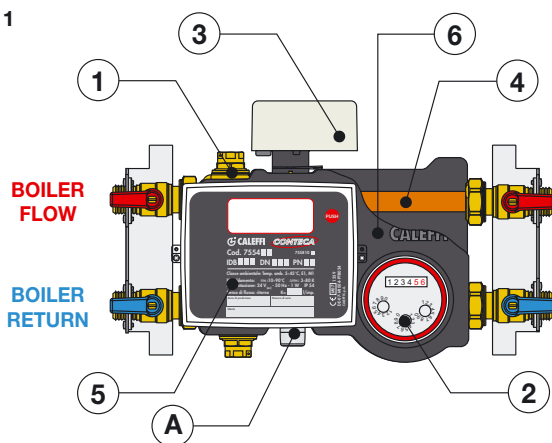

The hydraulic module includes:

- 1) zone valve assembly complete with temperature probe pockets
- 2) volume meter Ø 3/4", 7554 series
- 3) actuator, 6440 series
- 4) template for AUTOFLOW®, code 700075
- 5) CONTECA electronic panel, 7554 series
- 6) insulation

700015 - hydraulic module DN 3/4", actuator 230 V

700016 - hydraulic module DN 3/4", actuator 24 V

Note: By adjusting the by-pass knob (A), the module can be changed from a two-way module (by-pass closed) to three-way module with adjustable by-pass.

The hydraulic module can be connected via the left-hand connection or the right-hand connection, provided that the direction of flow is respected.

Actuator specifications

3-contact actuator.

Auxiliary microswitch.

Power consumption: 4 VA.

Ambient temperature range: 0–55°C.

Protection class:

IP 44 (vertical control stem),

IP 40 (horizontal control stem).

Operating time: 40 s (90° rotation).

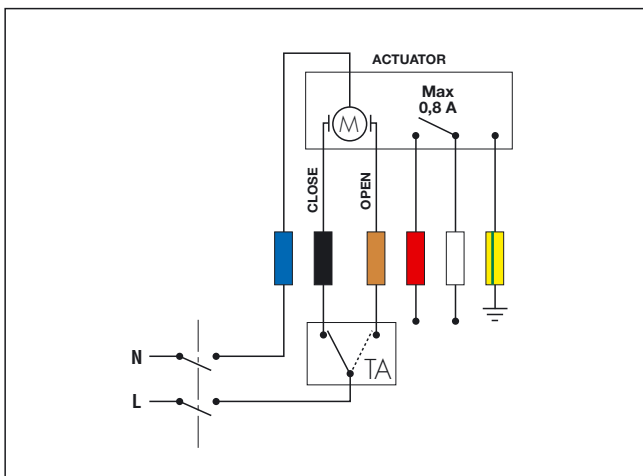

Note: For further details, please see

broch. 01131

Bracketing the electronic metering panel

The PLURIMOD hydraulic module code 700015/16 is supplied for hydraulic installation as shown in Fig. 1 (LHS riser).

If installation on the RHS riser is required, the following steps will be necessary:

1. Remove the CONTECA electronic panel (5) by turning it anticlockwise and remove the metal plate (B) by loosening the fixing screws.
2. Open the electronic panel and disconnect the pulse cable of the flow rate gauge (terminal 9/10). Remove the insulation (6).

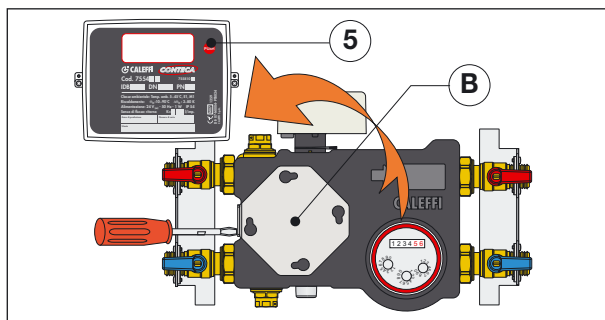

3. Disconnect the module from the ball valves.
4. Turn the module by 180° in relation to the zone valve axis. Remove the closure disc (C).

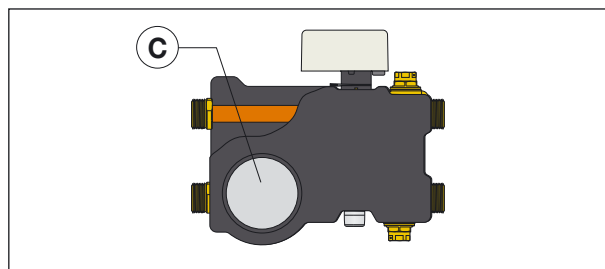

5. Turn the flow water by 180°, observing the flow direction.

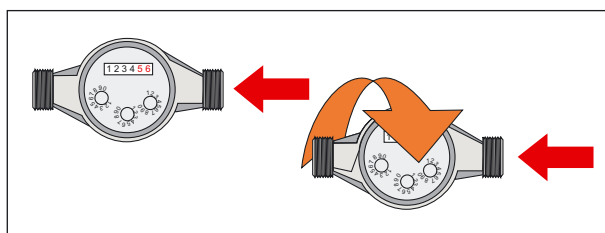

6. Replace the insulation and the closure disc.
7. Fix the locking plate in place.

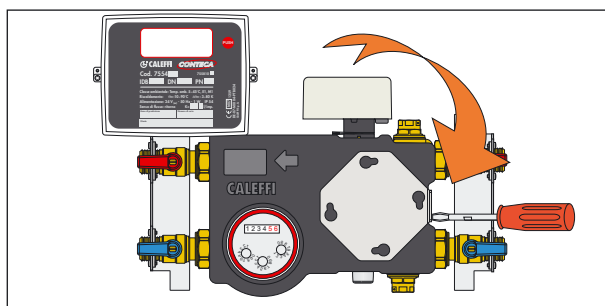

8. Reconnect the module to the ball valves.
9. Reattach the electronic panel and connect the pulse cable for the flow meter.
10. Close the CONTECA electronic panel again.

Hydraulic characteristics

A) Hydraulic module with open zone valve

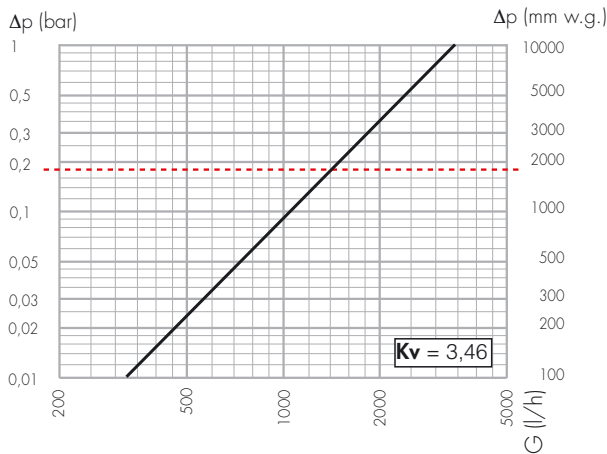

Operating range (noise)

To protect users from noise which may be generated inside the plumbing unit it is necessary to ensure a flow rate value which is below the noise threshold relating to differential pressures. The following values are provided as an indication.

Noise limits - Δp (mm w.g.)	
$\Delta p \leq 1800$	Noise unlikely
$1800 < \Delta p < 2200$	Noise likely
$\Delta p \geq 2200$	Noise very likely

The dotted red line in diagram A indicates the max. limit of the operating flow rate

$$G = 3,46 \sqrt{0,18} = 1460 \text{ l/h}$$

which corresponds to a velocity, reached by the medium, of approximately 1,2 m/sec.

Inspecting the strainer

Loosen cap A (with 24 mm wrench) to access the filter easily for regular inspection and maintenance.

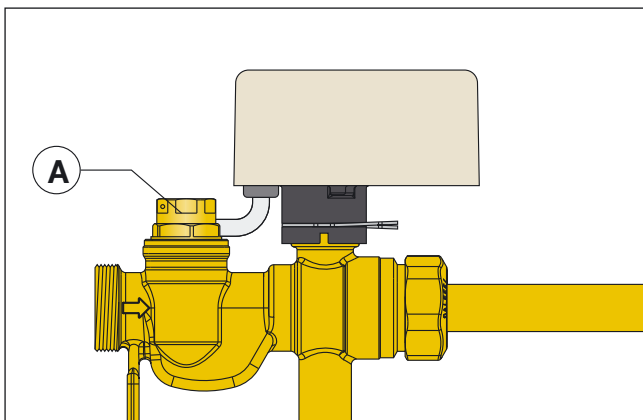

B) Hydraulic module with closed zone valve

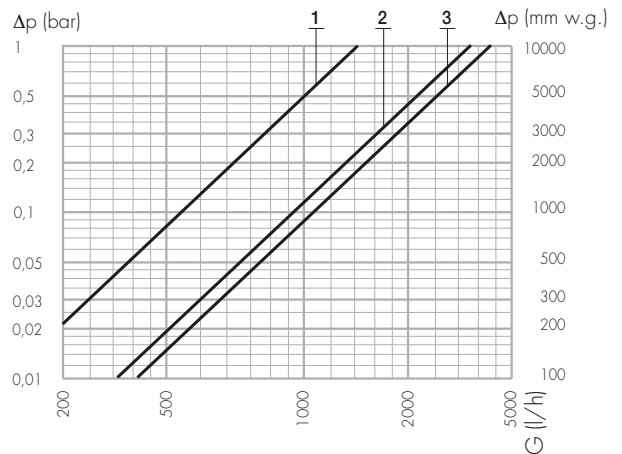

- 1 By-pass open by 1 turn; $K_v = 0,72$
- 2 By-pass open by 2 turns; $K_v = 1,47$
- 3 By-pass completely open; $K_v = 1,77$

700075... Compact automatic flow rate regulator



By removing the template sleeve ((4) in Fig. 1), it is possible to connect the flow rate regulator code 700075...

... To complete the code, please consult the table below:

with range Δp 15–200 kPa													
m ³ /h	...	digit	m ³ /h	...	digit	m ³ /h	...	digit	m ³ /h	...	digit		
0,12	M12		0,25	M25		0,40	M40		0,70	M70		1,00	1M0
0,15	M15		0,30	M30		0,50	M50		0,80	M80		1,20	1M2
0,20	M20		0,35	M35		0,60	M60		0,90	M90		1,40	1M4

Example: maximum flow rate required 600 l/h, code 700075 M60

HYDRAULIC OPTIONS

700050 - 700051 Domestic water function



700050 DHW / DCW function with local reading 3/4" M x 3/4" M

700051 DHW / DCW function with pulse output 3/4" M x 3/4" M

Characteristic components:

- BALLSTOP valve with built-in check valve Ø 3/4" M
- Template connection point
- Shut-off ball valve Ø 3/4" M with male terminal
- Domestic water meter (supplied)
2004/22/EC certification

Technical data domestic water function

In conformity with directive 2004/22/CE (MID 001)

Dimensions	COLD WATER		HOT WATER	
	1/2"	3/4"	1/2"	3/4"
Single jet meter	PN 16			
Permanent flow rate Q ₃	1.600 l/h	2.500 l/h	1.600 l/h	2.500 l/h
Overload flow rate Q ₄	2.000 l/h	3.125 l/h	2.000 l/h	3.125 l/h
Working temperature range	0,1–30°C		30–90°C	
Horizontal installation (H)				
Minimum flow rate Q ₁	32 l/h	50 l/h	32 l/h	50 l/h
Transitional flow rate Q ₂	128 l/h	200 l/h	128 l/h	200 l/h
Vertical installation (V)				
Minimum flow rate Q ₁	64 l/h	100 l/h	64 l/h	100 l/h
Transitional flow rate Q ₂	160 l/h	250 l/h	160 l/h	250 l/h
Max % error	per Q ₂ ≤ Q ≤ Q ₄		±2%	
	per Q ₁ ≤ Q ≤ Q ₂		±5%	
			±3%	
			±5%	

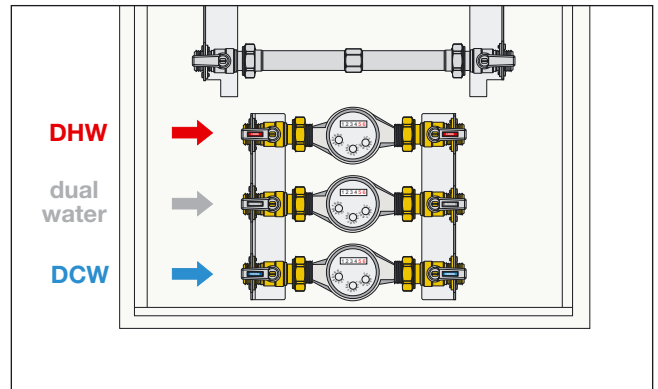

- Notes:**
- before bracketing the domestic hot water function onto the template supports, check the flow direction indicated on the BALLSTOP body valve.
 - before bracketing the water meter, check the flow direction marked on the meter body itself.

To prevent dripping caused by condensation, it is wise to position the domestic cold water (DCW) or dual water (DW) gauge on the lower part of the template supports.

Note: the DHW/DCW functions are supplied separately. The template connection point allows **the hydraulic water network to be flushed** before installation takes place. The positive displacement meter is **supplied**, for subsequent hydraulic bracketing and any necessary electrical wiring on the electronic panel.

700055 Mix function



Components:

Mixing valve 5217 series with anti-scald safety function, certified to NF 079 standard with temperature adjustment 30–50°C

Copper pipes and fittings: Max. working pressure: 10 bar
Max. inlet temperature: 85°C

User connections 1/2" M with union

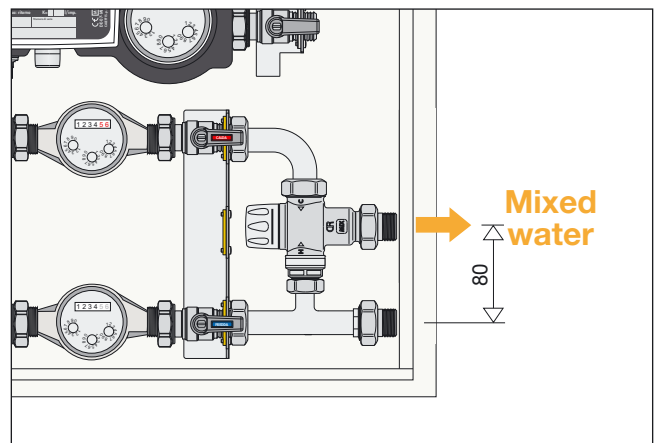

Note: The mix function requires the presence of two domestic water functions (DHW - DCW) code 700050/700051 and excludes the option of a third domestic water function.

Note: for further details, please see  [broch. 01092](#)

CONTECA heat meter, 7554 series

Conforms to directive 2004/22/EC/MID

Accuracy class: 3 according to EN 1434



Terminal board - electric cables and signals

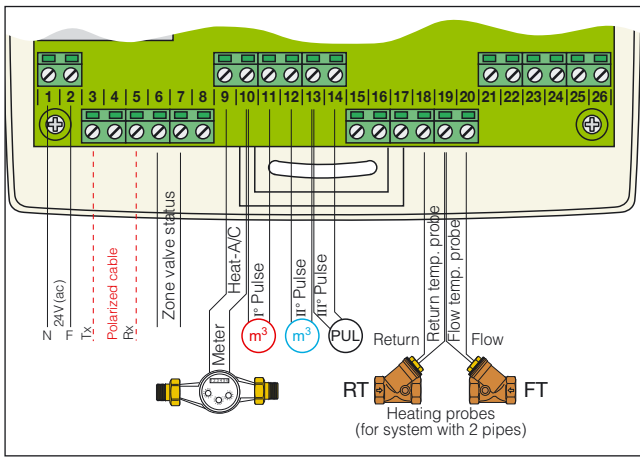

The CONTECA heat meter features various metering configurations referring to two-pipe and aggregated pulse acquisition systems that determine set connection positions.

1) Thermie and/or refrigeration unit metering

- 6 7 Zone valve status*
- 9 -10 Mass meter
- 19 -20 Flow probe (TA)
- 18 -19 Return probe (RT)

2) Pulse acquisition (Type OA-OC)

2.1) One single pulse meter

- 10 -11 DHW or DCW (1st pulse consumption)

2.2) Two pulse meters

- 10 -11 DHW (1st pulse consumption)
- 12 -13 DCW (2nd pulse consumption)

2.2) Three pulse meters

- 10 -11 DHW (1st pulse consumption)
- 12 -13 DCW (2nd pulse consumption)
- 13 -14 Generic/Dual (3rd pulse consumption)

Technical specifications

Temperature probe

Type: NTC
 Temperature difference limit: 3-80 K
 Measurement sensitivity: $\leq 0,05^{\circ}\text{C}$

Water meter

Nominal pressure: PN10
 Maximum temperature of the medium: 90°C
 Lowest flow rate Q_l : 50 l/h
 Nominal flow rate Q_p : 2500 l/h
 Installation: horizontal / vertical

Calculation unit

Metrological specifications: conformity to EN 1434-1
 2004/22/EC MID
 Centralised transmission: in M-Bus mode
 Ambient classification: MID 2004/22/EC E1-M1
 Supply: 24 V (ac) - 1 W - 50 Hz
 Protection class in accordance with DIN 40050: IP 54

User information cycle

The heat meter is equipped with a liquid crystal display. The display is activated by pressing the button on the front **PUSH**. By repeatedly pressing the button briefly it is possible to scroll through the various information windows. In order to extend the battery life, the display is switched off 30 s after the sensor button was last pressed.

Heating - Energy (Thermie)

E 1+ 0 kWh

Cooling - Energy (Refrigeration units)

E 1- 0 kWh

Carrier medium volume

0 04 m³

1st pulse consumption

1 1

2nd pulse consumption

2 0

3rd pulse consumption

3 0

Flow rate

1 8000 m³/h

Power

1 00 kW

Flow temperature

1 r 29.1 °C

Return temperature

1 r 28.6 °C

Note: for further details, please see broch. 01111

*Compulsory connection for consumption certification

ELECTRIC-ELECTRONIC OPTIONS

755890 Remote energy totaliser



Electronic 8-digit LCD totaliser equipped with cover plate for three-slot **recessed electric box**, for **remote monitoring of thermie or refrigeration unit consumption**.
Lithium battery: duration 8 years - max. frequency 20 Hz.
Cable section (2x1 mm²), max. length 150 m.

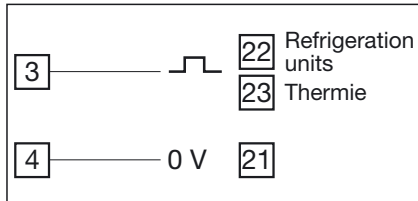

755810 Refrigeration unit metering

The CONTECA meter, via software, is able to **keep a record of the thermie and refrigeration units in separate registers through the evaluation of the thermal gradient inversion**.

75588. Pulse output

The pulse output can be used to transfer the thermie and/or refrigeration unit energy values to a generic acquirer. **The pulse weighs 1 kWh**.

The pulse output with no potential is an **open collector** with pulse period 120 ms - Vmax 24 V (dc).

Code

755881	Single pulse output - THERMIE
755882	Double pulse output - THERMIE/REFRIGERATION UNITS

DATA CENTRALISATION

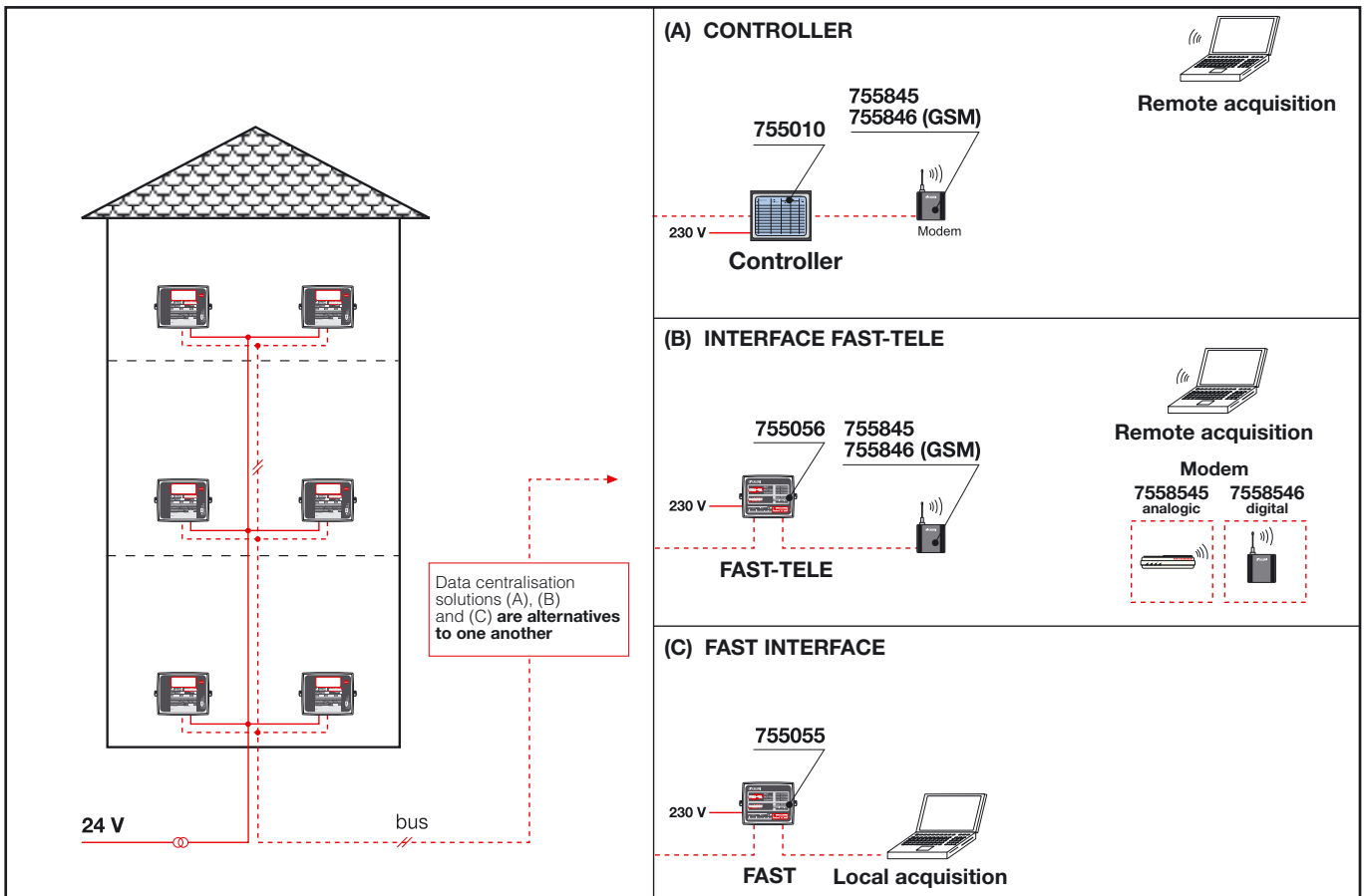

N.B.: The transmission bus code 755855/N is a two-way device (section 2 x 1 mm²).
The controller allows a **maximum of 250 users**. The laying methods are in accordance with the tree distribution (star).
The **maximum length** of each individual section is **1200 m**.
It is possible to lay up to a **maximum of 4 separate sections**.

Note: for further details, please see [broch. 01111](#)

SPECIFICATION SUMMARY

Code 700005

Template for PLURIMOD universal positioning user module, consisting of:

- Box made of painted plate for interiors (RAL 9010) with universal closure door.
(w = 520 - h = 520 - d = 110-150 mm).
- Two pairs of ball shut-off valves 3/4" M.
- Flushing pipes for checking water tightness and washing the system.
- Triple domestic water function positioning flaps (DHW - DCW - Dual water or technical function).

Code 700015/16

PLURIMOD universal positioning hydraulic module with adjustable configuration from two-way to three-way, with adjustable by-pass. Equipped with:

- Hydraulic unit with ball zone valve and pockets for temperature gauges.
- Actuator, 6440 series, supply 230 V for code 700015 or 24 V (ac) for code 700016.
- CONTECA heat meter - EC 2004/22 certification (MID).
- Template for AUTOFLOW®.
- Insulation.

Code 700050/51

Domestic cold water (DCW) function, domestic hot water (DHW) function and dual water (DW) or technical function equipped with:

- BALLSTOP shut-off ball valve with built-in check valve.
- Water meter without pulse output (K 10) Ø 3/4" code 700050; with pulse output code 700051.
- Shut-off ball valve with male terminal.
- Template connection point for water meter.

Code 700055

Domestic water MIX function consisting of:

- Thermostatic mixing valve, 5217 series, Ø 3/4" certified to standard NF 079 doc. 8.
- Copper pipes and quick push-fit connections.

Code 700075...

Compact automatic flow rate regulator, AUTOFLOW®. Quick push-fit connections. Brass body. High resistance polymer cartridge. Stainless steel spring. EPDM seals. Medium water and glycol solutions. Maximum percentage of glycol 50%. Maximum working pressure 16 bar. Working temperature range 0-100°C. Range Δp 15-200 kPa. Range of available flow rates 0,12-1,4 m³/h. Accuracy $\pm 10\%$.

Code 700010

Compact touch-screen CONTECA controller, with RS232 - RS485, USB and LAN ports, user monitoring function (maximum 250) and daily logging of consumption data. Enabled for SMS message alarm and remote activation management, and for automatic transmission of data via FTP server. Supply 230 V (ac).

We reserve the right to change our products and their relevant technical data, contained in this publication, at any time and without prior notice.



CALEFFI S.P.A. · S.R.229, N.25 · 28010 FONTANETO D'AGOGNA (NO) · ITALY · TEL. +39 0322 8491 · FAX +39 0322 863723

· www.caleffi.com · info@caleffi.com ·

© Copyright 2009 Caleffi