

521331CST, 521332CST & 521931CST

thermostatic mixing valve
tmv2

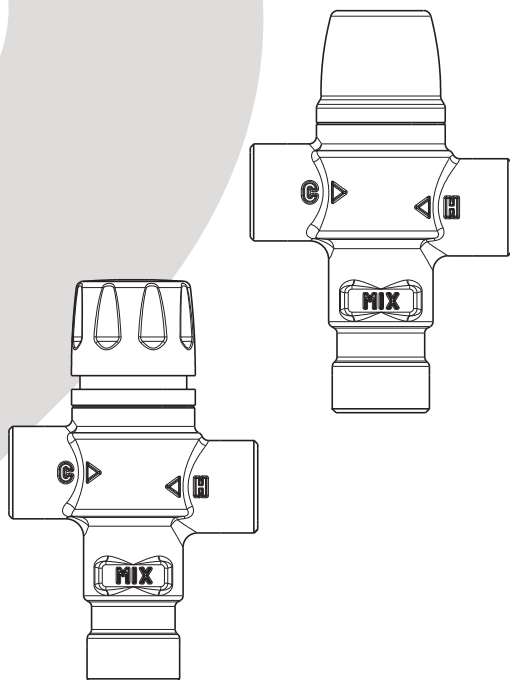

installation guide



web: www.caleffi.com
email: info@caleffi.it

altecnic

521331CST, 521332CST & 521931CST tmv2 thermostatic mixing valve

These installation instructions are for the Altecnic 521331CST - preset valve @ 61°C, 521332CST - preset valve @ 51°C and the 521931CST - adjustable valve 35 to 65°C

The following information is required for use when the Altecnic 521331CST, 521332CST and 521931CST thermostatic mixing valves are used in a TMV2 Applications under the requirements of BS EN 1111: 1999 "Sanitary tap ware – Thermostatic Mixing Valve (PN 10) – General Technical Specification".

General Technical Specification and BS EN 1287: 1999 "Sanitary tapware. Low pressure thermostatic mixing valves. General technical specifications".

Introduction

The Altecnic range of thermostatic mixing valves have been specifically designed and manufactured to meet the requirements of BS EN 1111: 1999, BS EN 1287: 1999 and TMV2 Type Scheme. The valve has been independently tested and approved as a TYPE 2 valve under the Buildcert TMV2 scheme by WRC - NSF Limited / Buildcert Limited.

Technical Specification / Conditions for use TMV2 Valves

	High Pressure BS EN 1111	Low Pressure BS EN 1287
Max. Static Pressure	10 bar	10 bar
Flow Pressure, Hot & Cold	0.5 - 5 bar	0.1 - 1.0 bar
Hot Supply Temperature	55°C - 65°C	55°C - 65°C
Cold Supply Temperature	≤25°C	≤25°C
Temperature Stability	±2°C	±2°C
Min. Temp Differential (Mix to Hot) for fail-safe	10°C	10°C
Max. Pressure Inlet Differential	5:1	5:1

NOTE: Valves operating outside these conditions cannot be guaranteed by the Scheme to operate as Type 2 valves.

Approvals

Buildcert Scheme Approval Number:

Details Available on Request

WRAS Scheme Approval Number:

Details Available on Request



521331CST, 521332CST & 521931CST tmv2 thermostatic mixing valve

Dimensions

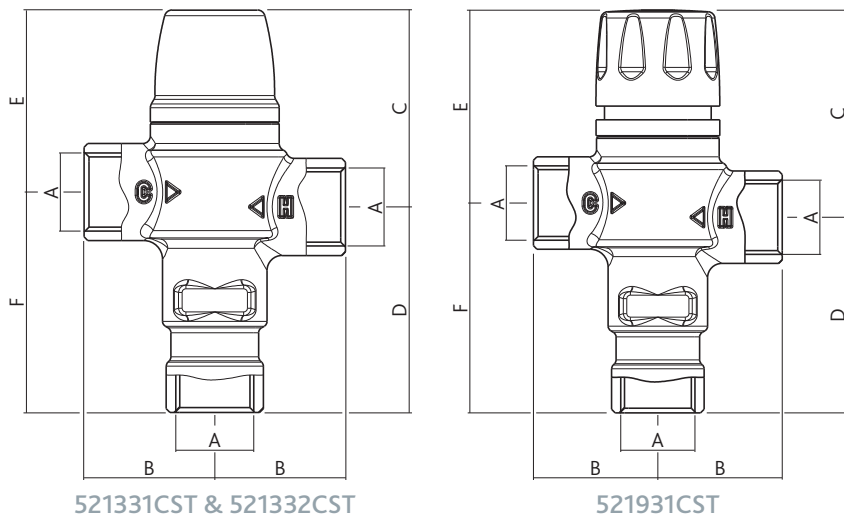

Code	A mm	B mm	C mm	D mm	E mm	F mm
521931CST	G½	35	53	55	49	59
521331CST	G½	35	55 to 59	55	51 to 55	59
521332CST	G½	35	55 to 59	55	51 to 55	59

Flowrates

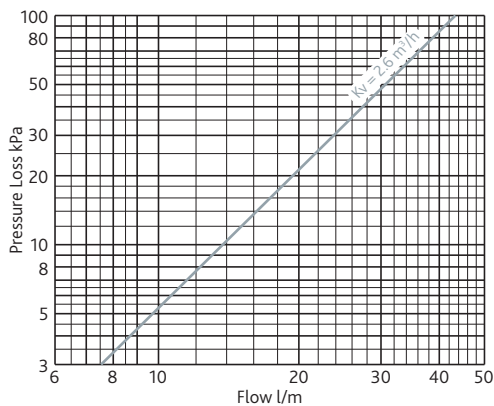

altecnic

Application

The valves designation of use, LP if tested against BS EN 1287, HP if tested against BS EN 1111 and HP and LP if tested against both standards.

The Altecnic range of thermostatic mixing valves have been independently tested by WRC and certified as meeting the requirements of the BS EN 1111:1999 and BS EN 1287: 1999 under the TMV2 Scheme as being suitable for use on the following designations.

This product is designed and certified for the following designations

Wash Hand Basin	HP & LP
Shower	HP & LP
Bidet	HP & LP

If a water supply is fed by gravity then the supply pressure should be verified to ensure the conditions of use are appropriate for the valve. The installation of thermostatic mixing valves must comply with the requirements of the Water Supply (Water Fittings) Regulations 1999..

Recommended Outlet Temperatures

The Buildcert TMV scheme recommends the following set maximum mixed water outlet temperatures for use in all premises:

Application	Recommended Set Mixed Water Temp.
Wash Hand Basin	41°C
Shower	41°C
Bidet	38°C

The mixed water temperatures must never exceed 46°C. The maximum mixed water temperature can be 2°C above the recommended maximum set outlet temperatures.

NOTE: 46°C is the maximum mixed water temperature from the bath tap. The maximum temperature takes account of the allowable temperature tolerances inherent in the thermostatic mixing valves and temperature losses in metal baths. It is not a safe bathing temperature for adults or children.

The British Burns Association recommends 37°C to 37.5°C as a comfortable bathing temperature for children. In premises covered by Care Standards Act 2000, the maximum mixed water outlet temperature is 43°C.

Installation

IMPORTANT - The following instructions must be read prior to the installation of any Altecnic thermostatic mixing valve, the installer should also be aware of their responsibility and duty of care to ensure that all aspects of the installation comply with all current regulations and legislation. It has been brought to our attention that flushing through water systems using certain chemicals may wholly or partially remove the lubricant from the internal workings of the valve, which may adversely affect its performance. We recommend that following flushing of the system with chemicals; valves are checked for correct operations.

The installation of thermostatic mixing valves must comply with the requirements of the Water Supply (Water Fittings) Regulations 1999.

Installation

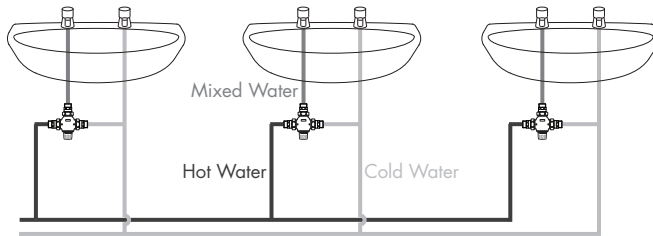

The Altecnic range of thermostatic mixing valves MUST be installed in an accessible position to ensure that maintenance, commissioning and testing of the Thermostatic Mixing Valves can be undertaken easily.

- 1 It is essential that before installing any of the Altecnic range of thermostatic mixing valves ensure that the supply conditions of the system to which the valve is intended to be fitted are checked to confirm compliance with the parameters as quoted within the Technical Specification and conditions on which the approval is granted i.e. verify supply temperatures, supply pressures, risk assessment.
- 2 Consideration must be made for the possibility of multiple / simultaneous demands being made on the supply system whilst the Altecnic thermostatic mixing valves is in use, all practical precautions must be made to ensure that the valve is not affected. Failure to make provision within the pipe sizing etc. will affect the performance of the valve.
- 3 The supply system to which the Altecnic thermostatic mixing valve is to be installed into must be thoroughly flushed and cleaned to remove any debris, which may have accumulated during the installation. Failure to remove any debris will affect the performance and the manufacturer's warranty of the product. Independent filters / check valves and isolation valves must be fitted in conjunction with the valve. In areas that are subject to aggressive water, provision must be made to treat the supplies prior to the supplies entering any Altecnic product.
- 4 The maximum flow rate of the valve will only be achieved when the supply conditions are achieved as quoted within the Technical Specification, with a flow condition under 1 bar differential pressure.
- 5 The Altecnic range of thermostatic mixing valves have been designed to ensure that the valve can be installed in any position whether vertical or horizontal, it can be surface mounted or within a supply duct. It is essential that access to the valve is not obstructed for any future maintenance that may be required to the valve or associated fittings.
- 6 We recommend that the Altecnic thermostatic mixing valve be installed as close as practically possible to the outlet, which it is serving. In this situation attention must be paid to the maximum distance of pipe work from the mixed water outlet of the valve to any terminal fitting.
- 7 Current guideline recommended a maximum distance of 2m from the outlet of any mixing valve to the furthest terminal fitting / outlet to which the mixing valve is to serve.
- 8 The hot and cold water supplies must be connected to the valve strictly in accordance with the indications on the body of the valve i.e. hot water supply to the hot port of the valve.
- 9 In a situation where one or both of the water supplies are excessive, it is possible to fit a pressure reducing valve to reduce the pressure(s) to within the limits as quoted previously.
- 10 Any thermostatic mixing valve must be fitted with a back flow prevention device, such as check valves to prevent the cross contamination of supplies.

Installation

- 11 Y Pattern strainers and full-bore isolation valves must be installed in conjunction with the Altecnic range of fail-safe thermostatic mixing valves – the Y Pattern Strainers and isolation ball valves must be fitted as close a practically possible to the valve.
- 12 It is essential that the Altecnic range of thermostatic mixing valves should not be installed in situations where there is a possibility of the valve being deprived of water or where demands for water are greater than the actual stored supplies.
- 13 To ensure that the performance levels of the Altecnic range of thermostatic mixing valves are maintained (in the event of cold water failure), the temperature of the hot water supply at the point of entry to the valves must be a minimum of 15°C above the commissioned mixed water discharge temperature.
- 14 The Altecnic range of fail-safe thermostatic mixing valves must not be subject to any extreme temperature variations either during the installation or under normal operating conditions.

Method of Adjusting the Mixed Water Outlet Temperature

IMPORTANT - The following instructions must be read and understood prior to the adjustment of the mixed water outlet temperature and this action **MUST** only be carried out by a suitably qualified person.

- 1 521331CST & 521332CST - Remove the cap from the valve.
- 2 521331CST & 521332CST - Remove the temperature locking ring from the spindle using a suitably sized spanner.
- 3 Open the outlet to which the mixing valve is supplying and establish as stable flow and temperature.
- 4 Using a calibrated thermometer place the sensing part of the thermometer probe under the flowing water.
- 5 521331CST & 521332CST - Using the hexagonal recess in the inverted cap, turn the temperature adjustment spindle clockwise to increase the mixed water temperature or anti close wise to reduce the mixed water temperature – at all times ensuring the probe of the thermometer is under the flowing water.
- 6 521931CST - Rotate the cap to turn the temperature adjustment spindle clockwise to increase the mixed water temperature or anti close wise to reduce the mixed water temperature – at all times ensuring the probe of the thermometer is under the flowing water.
- 7 521331CST & 521332CST - Once the desired temperature is reached – replace the temperature locking ring on the spindle and refit the cap of the valve.
- 8 Set the mixed water temperature to the required temperature. The temperature at the terminal fitting must never exceed 46°C.

Commissioning

IMPORTANT - The following instructions must be read and understood prior to the commissioning the Altecnic range of thermostatic mixing valves. When measuring any mixed water outlet temperature reading, the sensing part of the thermometer probe must be fully submerged in the water. If under any circumstances there are aspects to the installation / system which do not comply with the specification laid down, the valve **MUST NOT** be put into operation until the system / installation complies with our specification. However if all these conditions are met, proceed to set the temperature as follows;

- 1 Ensure the designation of thermostatic mixing valves matches the application and that the system is thoroughly cleaned and free from any debris prior to the commissioning of the Altecnic range of thermostatic mixing valves. The supply temperatures and pressures are within the valves operating range specified. Providing that all of these conditions are met, please follow the following steps to commission this product.
- 2 The commissioning of the temperatures must be carried out using a suitably calibrated thermometer – preferably a digital thermometer the sensing part of the thermometer probe must be fully submerged in the water when testing.

Commissioning

- 3 Each Valve must be commissioned taking into consideration any fluctuations, which may occur within the system due to simultaneous demands. It is advisable that any outlets which are connected to the same supply as the mixing valve is connected to, open during the setting of the mixed water temperature. During commissioning it is advisable to ensure that the water temperatures are established before any attempt to commission.
- 4 Once the supply temperatures are stable and the normal operating conditions are established, the valve can be commissioned, – the temperature setting can be adjusted by removing the cap and temperature locking ring from the valve body (see section method of adjusting mixed water temperature). We suggest that the following sequence is followed when commissioning the valve;
 - 4.1 Set the mixed water temperature to the required temperature, the temperature at the terminal fitting must never exceed 46°C.
 - 4.2 Measure and record the temperature of the hot and cold water supplies at the connection to the valve.
 - 4.3 Measure and record the temperature of the water discharging from the valve.
 - 4.4 Isolate the cold water supply to the valve and monitor the mixed water temperature.
 - 4.5 Measure and record the maximum mixed water temperature and the final temperature. The final temperature found during the test should not exceed the values quoted.
 - 4.6 Record all the equipment used during the commissioning.
 - 4.7 The mixed water temperature at the terminal fitting must never exceed 2°C above set temperature.
 - 4.8 The maximum mixed water supply temperature at the terminal fitting should not exceed 46°C.
- 5 Once the desired temperature is established remove the cap and secure the temperature spindle with the locking ring and replace the cap into its original position to prevent tampering by unauthorized persons. Ensure that the application, in which the valve will be used in, is appropriate for the approved designation.
- 6 The above information must be recorded and updated on every occasion when any work is carried out on the valve.

In Service Testing

The Altecnic range of thermostatic mixing valves should be tested against the original set temperature results once a year. It is a requirement that all TMV2 approved valves shall be verified against the original set temperature results once a year. When commissioning/testing is due the following performance checks shall be carried out. When measuring any mixed water outlet temperature reading the sensing part of the thermometer probe must be fully submerged in the water.

When testing is due the following performance checks shall be carried out;

- 1 Measure the mixed water temperature at the outlet.
- 2 Carry out the cold water supply isolation test by isolating the cold water supply to the TMV, wait for five seconds if water is still flowing check that the temperature is below 46°C.
- 3 If there is no significant change to the set outlet temperature ($\pm 2^{\circ}\text{C}$ or less change from the original settings) and the fail-safe shut off is functioning, then the valve is working correctly and no further service work is required.
- 4 If there is a residual flow during the commissioning or the annual verification (cold water supply isolation test), then this is acceptable providing the temperature of the water seeping from the valve is no more than 2°C above the designated maximum mixed water outlet temperature setting of the valve. Temperature readings should be taken at the normal flow rate after allowing for the system to stabilise.
- 5 If the Altecnic range of thermostatic mixing valves has been adjusted or serviced it must be re-commissioned and re-tested in accordance with these instructions.

Problem Solving

The following details are supplied for on site queries, should you require any further assistance our Technical Department can be contacted directly on 01785 218 200.

- 1 **Hot water at the cold tap**
 - Operation of the insert check valves is hindered, check the valve is seated correctly.
 - Check Valves not fitted.
 - Unbalanced hot/cold supply pressure.
- 2 **Fluctuating mixed water temperature**
 - Erratic supply temperatures at the inlets of the valve.
 - Starvation of the water supplied at the inlets of the valve.
 - Incorrect commissioning of the valve.
- 3 **Erratic flow**
 - Insufficient water supplies.
 - Fluctuations in the supply pressures/temperatures.
 - Adverse effect created by other draw off points on the system.
- 4 **No flow/reduced flow from valve**
 - In line filters are blocked.
 - Insufficient supply pressure.
 - Debris obstructing valve operation.
 - Valve requires servicing (Servicing kits available on request).
- 5 **Valve does not fail safe when tested**
 - Installation not in accordance with our recommendations.
 - The minimum temperature differential not achieved.
 - Internal mechanism hindered by debris.

Please leave this Manual for the User

In this procedure document we have endeavoured to make the information as accurate as possible. We cannot accept any responsibility should it be found that in any respect the information is inaccurate or incomplete or becomes so as a result of further developments or otherwise.

E & O.E

Altecnic Ltd Mustang Drive, Stafford, Staffordshire ST16 1GW
T: +44 (0)1785 218200 E: sales@altecnic.co.uk
Registered in England No: 2095101

altecnic.co.uk

IOM 005 03-12-15

The logo for Altecnic, featuring the word "altecnic" in a lowercase, sans-serif font. The letter "a" is stylized with a circular dot in the center.