



**ARCHITECTURAL ALUMINIUM
GLAZING SYSTEMS**





Company Profile	2
Doors and Framing Systems	4
Curtain Wall Systems	5
Window Systems	6
Our Network	7

Value through Design

ACS Limited specialise in the design, manufacture and supply of architectural aluminium glazing systems.

Our systems are suitable for all types of low-rise applications in a variety of markets.

ACS is part of Alcoa, the world's leading producer of primary aluminum, fabricated aluminum, and alumina, with 127,000 employees in 40 countries and \$20 billion in annual revenues. Alcoa's values begin with integrity, respect for our people, their safety and health, and for the environment within which we live and work, anywhere in the world. Today, Alcoa is growing worldwide, creating value for customers through innovation, technology and operational expertise.

ACS' product range includes doors, framing systems, curtain wall and window systems, all offering practical solutions at a realistic price. We pride ourselves in our understanding and focus on our customers' requirements, which allows us to develop flexible applications for a wide range of uses.

ACS distribution service is designed with our customers in mind, offering fast and efficient

response times to help give you the edge over your competition. Our dedicated support team have experience of providing you with the service that you require to meet your critical deadlines, full details of delivery schedules are listed later in this brochure.

Versatility through Application

Retail

Customers include many national companies such as Boots, Safeway and Iceland as well as many regional retailers.

Public Sector

ACS regularly works in partnership with housing associations, local authorities, housing consortia, health trusts and public utilities, advising on both refurbishment and new build projects.

Commercial

The ACS range of doors, framing systems, curtain wall and window systems can be applied to a wide range of commercial properties. All of our systems are designed with safety and security in mind.



Designer Outlet Village, Tillicoultry
Architect: Dalziel Design Partnership

10D Light/Medium Duty Commercial Entrance Door

Dedicated product development has created the ACS 10D Door System that is designed to offer flexibility of design, durability and ease of installation. The system is ideally suited to light/medium traffic areas and can be used for a wide range of applications offering a choice of access options, including manual and automatic.

The ACS 10D Door System is currently used across a variety of markets, including the retail, commercial and public sectors.

- Square cut aluminium sections
- Mechanically joined using tie-rod construction for compressive strength
- Single glazing options from 6mm to 12mm
- Double glazing options from 18mm to 24 mm
- Internally drained



Transfer Technology Centre, Grimsby
Architect: North East Lincolnshire County Council



Section showing relationship between the Lock and Flush Bolt stile for the ACS 10D

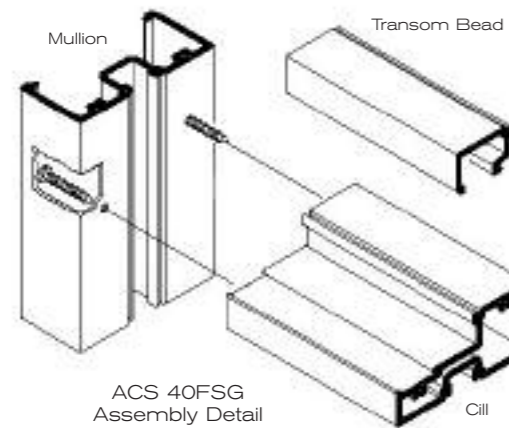

ACS 40FSG Assembly Detail

Framing Systems

The ACS 40FSG and ACS 40FDG framing systems have been designed for a wide range of applications and will accommodate numerous glazing options for both single and double-glazing. The double glazed option offers a cost effective solution for larger span applications. The system is internally drained and any moisture infiltration is directed to the outside of the building.

- Single glazed option has 100mm depth and 45mm width
- Single glazing up to 12mm thickness
- Double glazed option has 114mm depth and 51mm width
- Double glazing up to 26mm thickness
- Shear block and Screw Spline construction
- Flush glazed for ease of application



Designer Outlet Village, Tillicoultry
Architect: Dalziel Design Partnership

Curtain Wall Systems

Practicality of application was a fundamental requirement that was considered during the design and development of the ACS 20CW. Designed for low-rise vertical use, the ACS 20CW provides an inexpensive yet effective solution to architects, specifiers and fabricators alike. Its slim sight lines and range of face-cap options allow architects and designers the flexibility to create exciting and attractive building solutions, whatever the market.

- Mullion drained so there are no visible drainage slots
- Several standard mullion depths to suit individual project requirements
- Glazing options from 6mm to 39mm
- Slim 50mm sight lines



Kingswood Retail Park, Hull
Architect: David Lyons & Associates

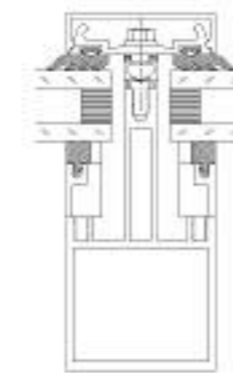

ACS 20CW Vertical Mullion

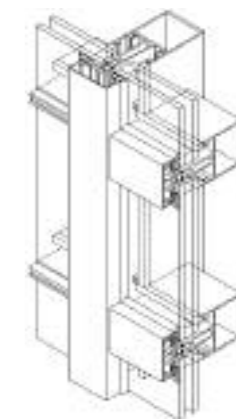

ACS 20CW Facecap Installation Assembly Detail

Window Systems

ACS window systems provide a comprehensive range of design options for the architect and specifier, suitable for both new build and replacement work. They are thermally broken, with casement, tilt-before-turn and pivot options.

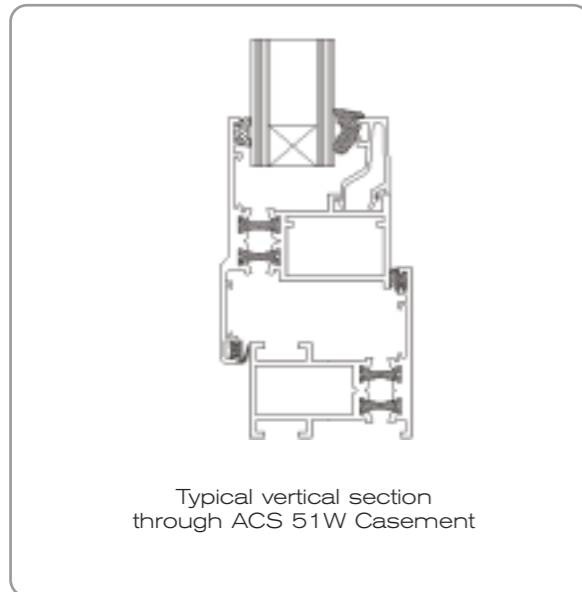

ACS 51W

The ACS 51W system offers a combination of maximum design flexibility and enhanced thermal performance.

A polyamide thermal break provides the architect and specifier with even more opportunities for new build projects. Available in casement, tilt before turn and pivot options.

- Glazing from 6mm to 32mm can be accommodated
- Weather performance in accordance with British standards
- Excellent aesthetics due to slim sightlines

Our Network

We have expertise in a broad range of markets and our technical team are happy to offer complete assistance throughout any stage of your project.

Representatives from ACS Ltd regularly visit architectural practices, fabricators premises and installation sites to provide advice and technical support to give every assistance necessary in the smooth progression of any project.

Support from ACS includes:

- A state of the art CAD system, to solve design problems quickly and efficiently, allowing computer generated drawings of aluminium sections to be integrated with building design drawings
- Extensive ex-stock service, supported by on-line hourly stock update facility
- Profile drawings for use on the majority of CAD systems are available in electronic format
- Product training and on-site support
- Comprehensive delivery services throughout the UK
- Delivery times from receipt of order:
 - Mill finish - 7 working days
 - Painted non-thermal - 7 working days
 - Painted and Thermally broken profiles - 14 working days





ACS Ltd
Alcoa, Astmoor Industrial Estate, Runcorn, Cheshire WA7 1QQ
Tel: 01928 502500 Fax: 01928 502501

www.kawneer.co.uk

Kawneer's continuous development and engineering programmes may bring about product changes. Kawneer reserves the right to introduce without notice such changes which will not detract from the product's performance
© KAWNEER UK LTD February 2009

