

1 Bay (3 Louvers)

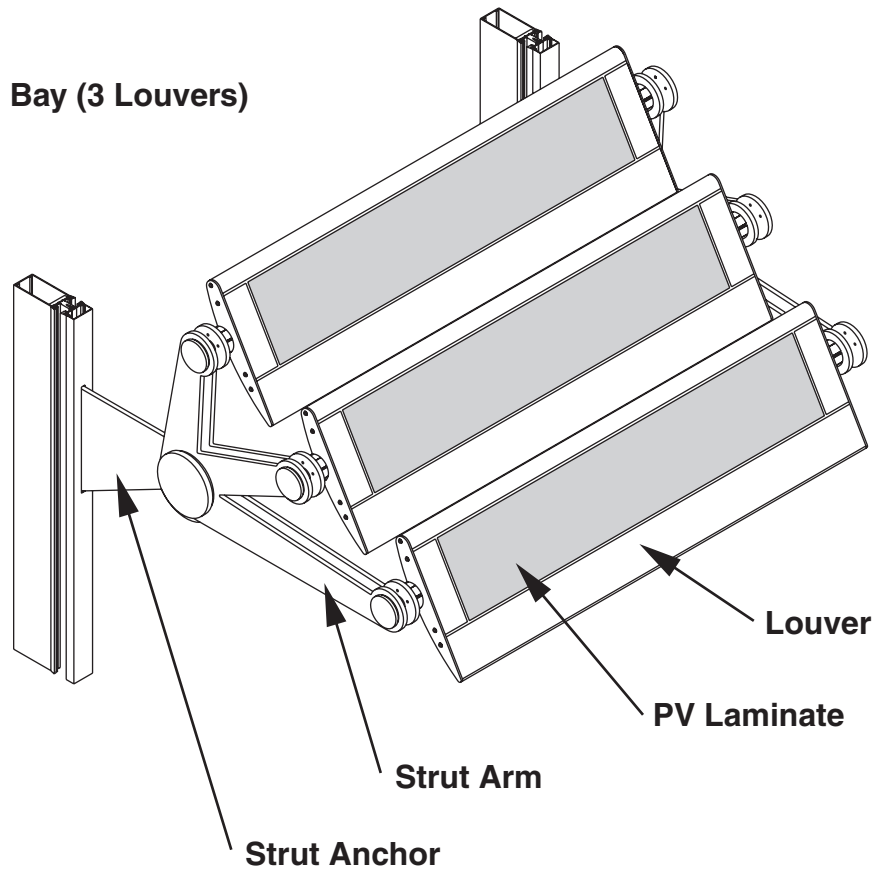

Features

- Clean lines complement curtain wall aesthetics and contemporary architectural applications
- Engineered to meet rigorous structural loads while minimizing material requirements
- Overall design addresses the need for environmentally responsible architecture
- 75 watts of electrical generation per bay (at peak performance)
- Laminate with crystalline photovoltaic (PV) cells structurally glazed into aluminum substrate
- High performance finish on all aluminum components; designed to endure for the life of the building
- Two non-articulating pivot points set tilt to optimize electrical generation and minimize unwanted solar heat gain
- Pre-fabricated Bay Assemblies are efficiently and quickly erected on-site
- No moving parts... Requires little or no maintenance

For specific product applications,
Consult your Kawneer representative.

Laws and building and safety codes governing the design and use of glazed entrance, window, and curtain wall products vary widely. Kawneer does not control the selection of product configurations, operating hardware, or glazing materials, and assumes no responsibility therefor.

Kawneer reserves the right to change configuration without prior notice when deemed necessary for product improvement.
© Kawneer Company, Inc., 2009

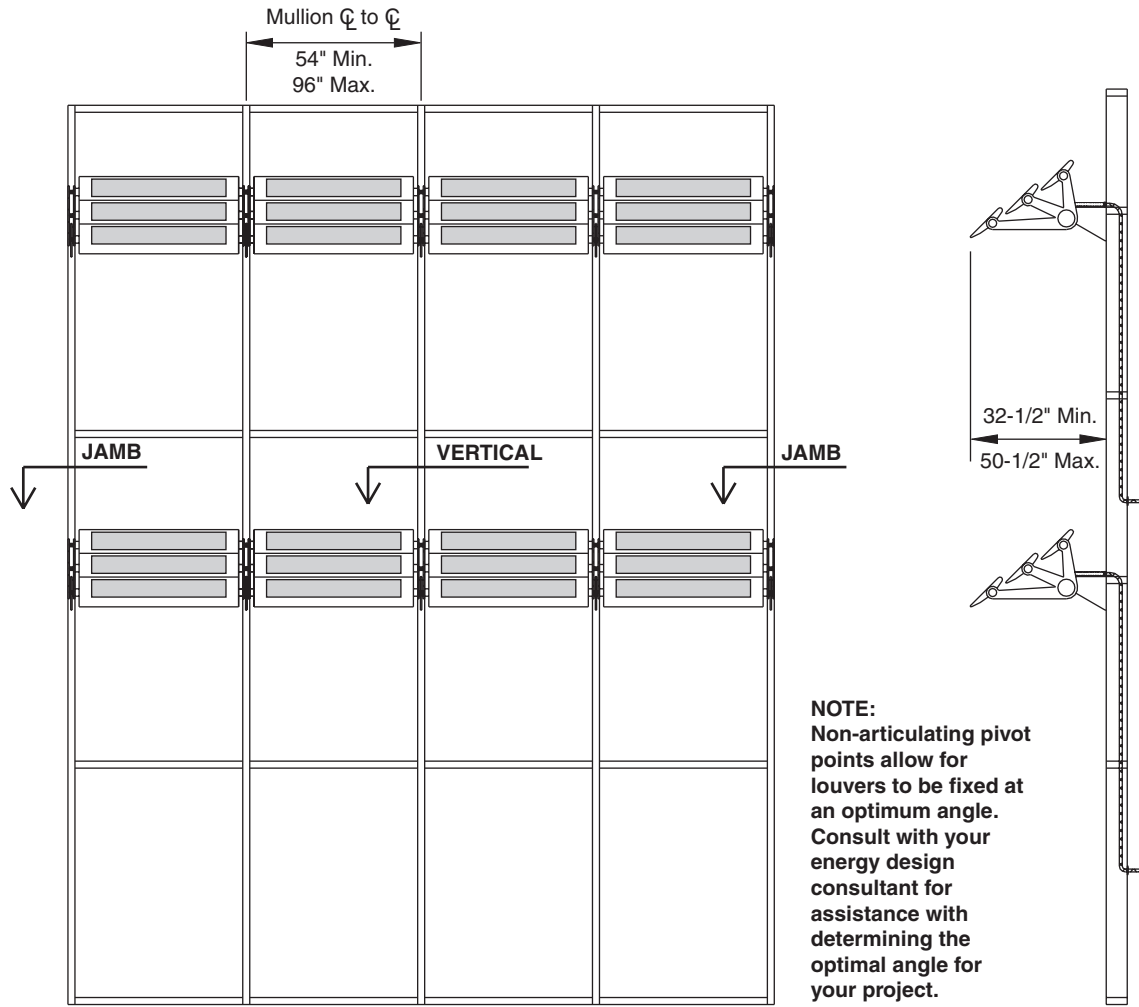

TYPICAL ELEVATION FACING SOUTH

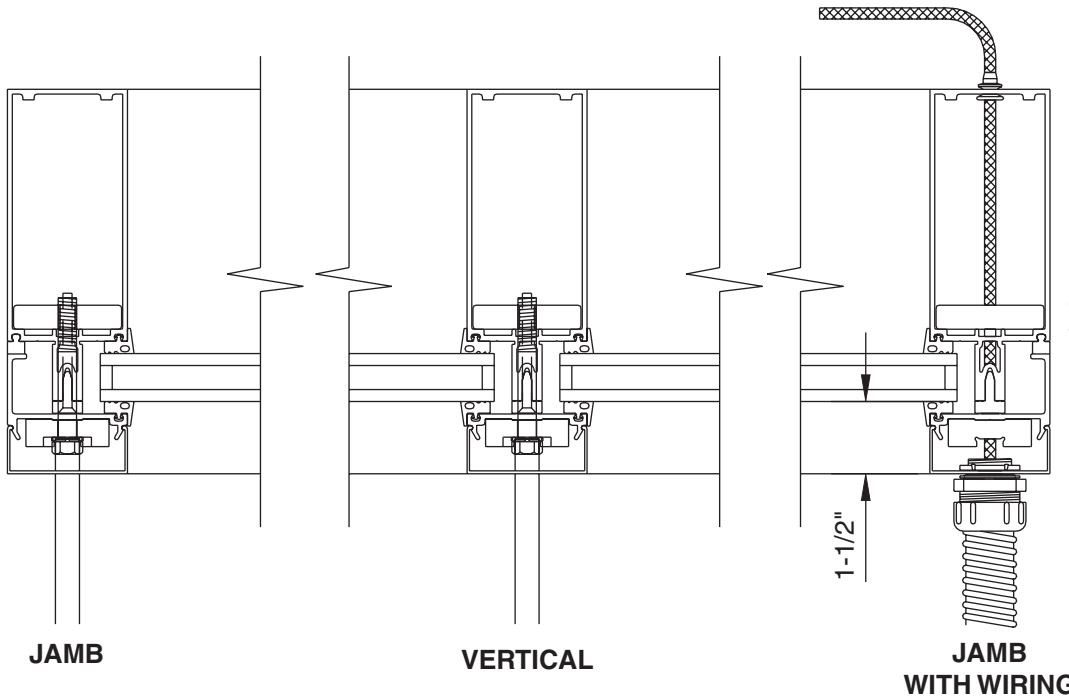

NOTE: Structural attachment is not shown in this view in order to highlight wiring integration.

Laws and building and safety codes governing the design and use of glazed entrance, window, and curtain wall products vary widely. Kawneer does not control the selection of product configurations, operating hardware, or glazing materials, and assumes no responsibility therefor.

Kawneer reserves the right to change configuration without prior notice when deemed necessary for product improvement.
© Kawneer Company, Inc., 2009

POSITIONING EXAMPLES

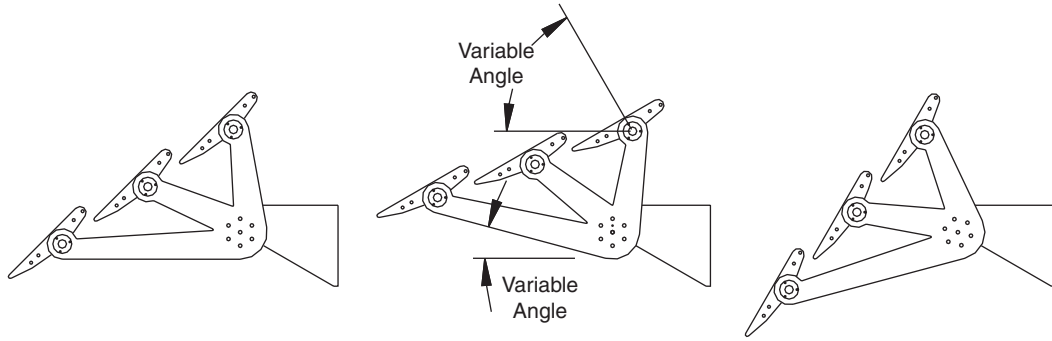

NOTE: BLADES ARE NON-ARTICULATING.

LOUVER OPTIONS

LOUVER CROSS SECTION WITH PHOTOVOLTAIC PANEL

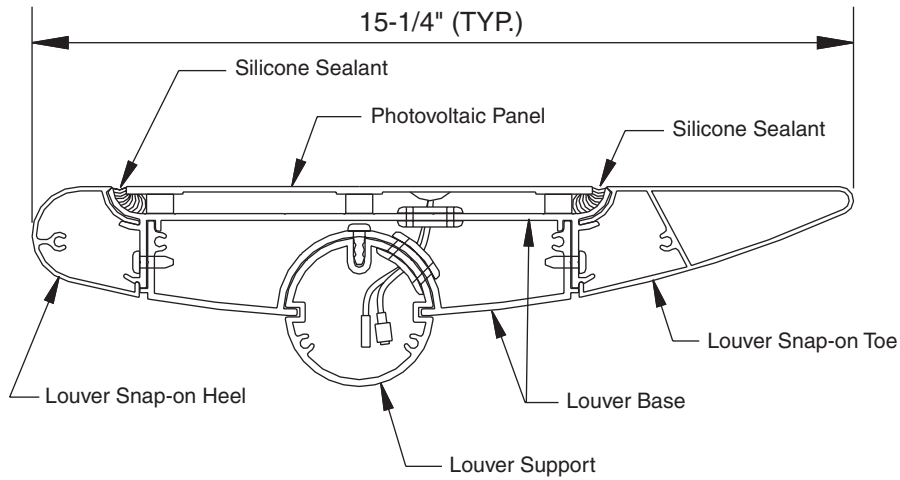

LOUVER CROSS SECTION WITH ALUMINUM PANEL

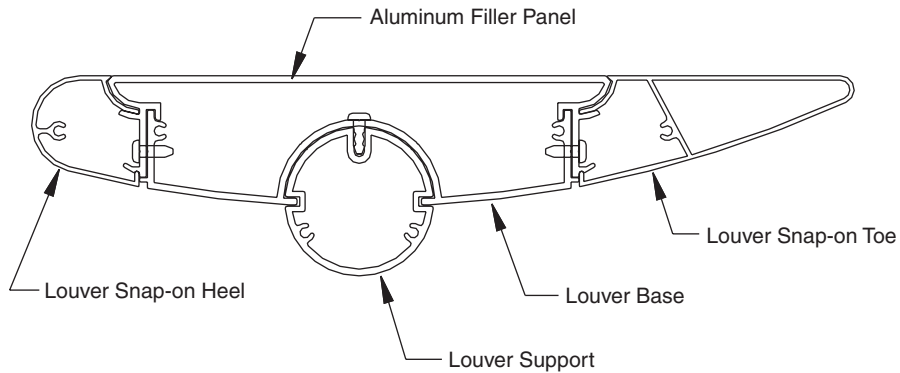

Laws and building and safety codes governing the design and use of glazed entrance, window, and curtain wall products vary widely. Kawneer does not control the selection of product configurations, operating hardware, or glazing materials, and assumes no responsibility therefor.

Kawneer reserves the right to change configuration without prior notice when deemed necessary for product improvement.

© Kawneer Company, Inc., 2009

TYPICAL SYSTEM SCHEMATIC

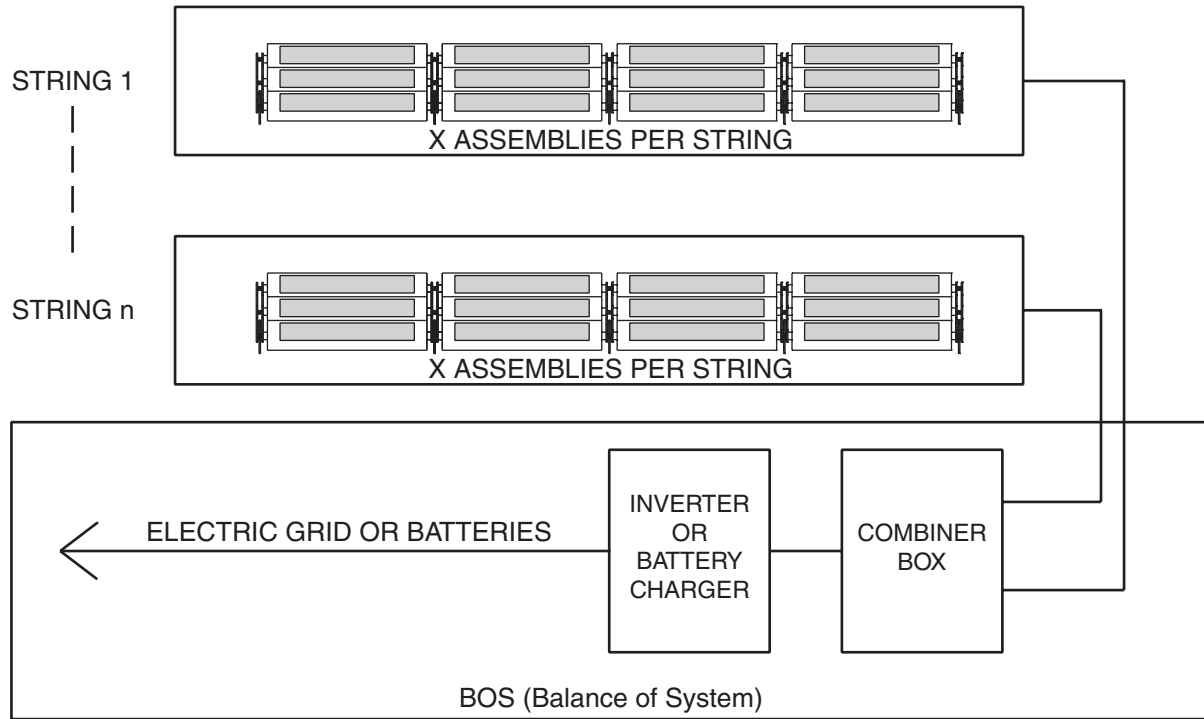

Laws and building and safety codes governing the design and use of glazed entrance, window, and curtain wall products vary widely. Kawneer does not control the selection of product configurations, operating hardware, or glazing materials, and assumes no responsibility therefor.

Kawneer reserves the right to change configuration without prior notice when deemed necessary for product improvement.
© Kawneer Company, Inc., 2009

PRODUCT NOTES

A. General

1. 1600 PowerShade® has been designed to be integrated into 1600 Wall System®1 ONLY.
2. A minimum of 15 bays of 1600 PowerShade® is required per order.
3. 1600 PowerShade® is also available with aluminum filler panels in lieu of photovoltaic panels for areas of the building or other applications in which power generation is impractical or not required.
4. Maximum bay width is 96". Minimum bay width is 54".
5. Strut Anchors and Strut Arms are painted only and can be painted to match anodized finishes. Louvers can be painted or anodized.
6. Due to the wide variety of building codes, load restrictions, and deflection criteria, the use of 1600 PowerShade® should be analyzed and approved by Kawneer Application Engineering on a project specific basis.
7. As with all photovoltaic systems, electrical engineering expertise is required to select appropriate balance of system hardware.

B. Electrical

1. Kawneer must be provided with:
 - A wiring diagram showing the number of PowerShade® assemblies in series (string).
 - Detailed elevation drawings showing proposed 1600 PowerShade® placement.
 - A wiring plan for the system from the facade to the inverters or battery chargers.
2. Inverters or other power conversion devices must be specified by a licensed PV systems integrator.
3. It is recommended that a shading study be undertaken to ensure that the 1600 PowerShade® will not be shaded during hours of peak production.
4. Inverters should be located as close as possible to reduce power losses through wiring.
5. Strings of PowerShade® assemblies should be separated by at least one bay to allow for wiring returns. Failure to do so may lead to power losses due to excessive wiring.
6. 1600 PowerShade® bonding (grounding) solutions vary by project and must be approved by a licensed professional engineer and/or authorities having jurisdiction.
7. 1600 PowerShade® is not UL certified.

FAQ

1. Do the 1600 PowerShade® blades move?

No, 1600 PowerShade® blades are set at an optimum angle based on the latitude and or other design requirements.

2. What kind of power is provided by 1600 PowerShade®?

1600 PowerShade® provides DC power which is then converted to AC power using an inverter. If a DC only system is required please contact a Kawneer representative.

3. Does the output of each assembly change with its width?

The maximum output is fixed at 25 Watts per louver, which totals to 75 Watts per three louver assembly.

4. Can I specify my own PV panel to be used with 1600 PowerShade® or buy extrusions and fabricate myself?

1600 PowerShade® is factory assembled and is engineered to work with a specific panel sourced by Kawneer.

5. What is the maximum and minimum width of a PowerShade® bay?

The width of a PowerShade® bay can range from 54" to 96". However, use of the PowerShade® at any bay width must be verified by Kawneer Application Engineering.

6. What type of solar photovoltaic technology is used in 1600 PowerShade®?

1600 PowerShade® captures the sun's energy using polycrystalline photovoltaic cells.

7. What color are the solar photovoltaic panels?

Each panel is made up of blue polycrystalline cells on a black backsheet.

8. Can 1600 PowerShade® be specified without solar PV panels?

Yes, 1600 PowerShade® has the option of being specified with an aluminum filler panel instead of a solar PV laminate.