

Albion

SECTIONS

TECHNICAL MANUAL
www.albionsections.co.uk

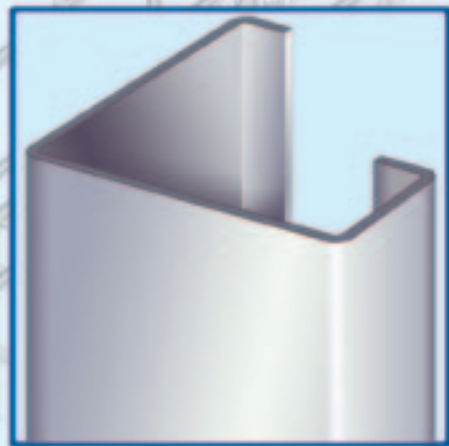
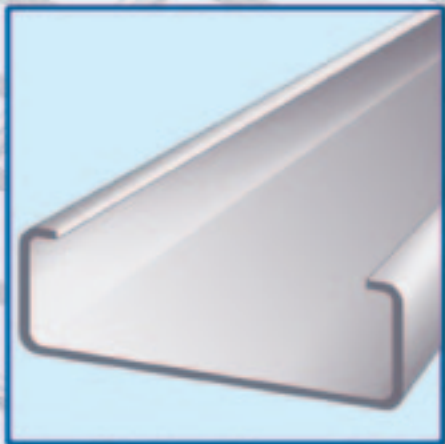
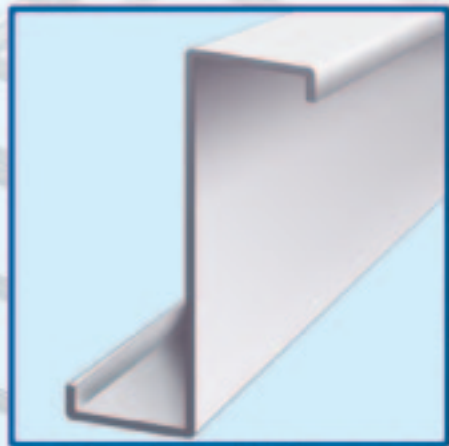
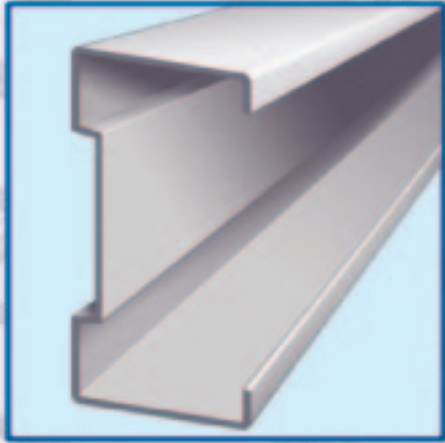

Z Purlins
C Sections
Eaves Beams

RAISING YOUR EXPECTATIONS

Albion

SECTIONS



Introduction

Dear Valued Customer,

Welcome to the Albion Sections Technical Manual.

Our latest brochure is the result of advancements made in our ongoing Development Program.

Driven by commercial economy and using the higher grade S450 material, extensive full scale testing has been undertaken at Birmingham University, under the supervision of Dr Jian Yang.

Although section depths remain the same, some flange widths have been reduced, to provide a more efficient strength/weight ratio. This, coupled with relatively minor changes to our standard sleeve details, provides a better cost effective solution.

Additional gauges are now incorporated within our range, keeping Albion Sections as the cold rolled solution providing the largest choice of economically designed sections available. The standard zed and lipped channel section range offers products from 120mm to 400mm deep and 1.2mm to 3.2mm thick.

Due to investment in state of the art rolling and punching facilities we are able to offer a solution using both M12 and M16 bolts, with you, the customer, able to specify your preference in bolt diameter in sections up to 245mm deep.

Our fully dynamic pre-punch facilities also provide alternatives when considering non standard details, when using specialised cladding systems and in and around door and window openings.

We at Albion are proud of our market leading delivery commitment. Planned expenditure this year has been commissioned and will provide an additional 6000 tonnes of capacity at our headquarters here in West Bromwich. We also offer a full manufacturing facility in Lisburn, Northern Ireland. This facility, opened January 2009, has capacity to support the comprehensive Albion range independently.

The Albion Sigma Purlin System, launched early 2009, provides a purlin solution with a high strength/weight ratio and reduced accessory requirements. Our market leading stud and track system provides effective options for infill panelling and specialised rainscreen claddings. We also offer design, detailing and installation of the system via our Associate Companies.

Our in-house designers and sales personnel will be happy to discuss particular projects. Brochure and software downloads, together with further information about Albion Sections, can be found at www.albionsections.co.uk

We encourage any feedback regarding the experience of choosing Albion products; please feel free to contact us.

Thank you for your interest in Albion Sections.

Yours Sincerely,

Albion
SECTIONS



Part of the Sebden Group

Z Purlins, C Sections & Eaves Beams

zed section dimensions.....	3
C section dimensions.....	3
eaves beams dimensions.....	4
component weights.....	5
product range.....	6 & 7
connections.....	8
typical jointing layouts.....	8 & 9
zed standard details and dimensions.....	10 & 11
C section standard details and dimensions.....	12 & 13
standard cleat details.....	13
eaves beam standard details and dimensions.....	14
cleats.....	15
mono pitched roof, typical layout.....	16
tiled roof, restraint recommendations.....	17
non restraining cladding system.....	18
anti sag bars.....	19 & 20
long roof slopes.....	20
side rail supports/eaves struts.....	21 & 22
diagonal tie wires.....	23 & 24
cleader angles and rafter stays.....	25
firewall rail system/sleeve details.....	26
horizontal cladding support systems.....	27, 28 & 29
vertical rail assemblies.....	30
window trimmers & door posts/counterformed holes.....	31
typical eaves/gutter details.....	32
examples of C section applications.....	33
top hat profile.....	34
cladding material weight.....	35

Albion Sections zed and c section are manufactured by cold roll forming pre-hot dipped galvanised steel S450 having a guaranteed minimum yield strength of 450N/mm² and a Z275 galvanised coating.

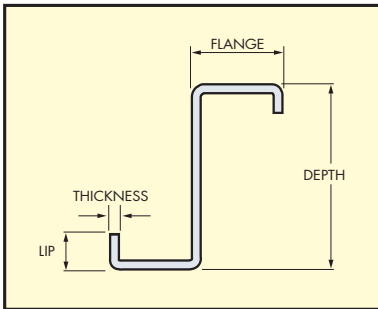

Sections marked * are available with 'Polycat' or Z600 galvanised coating finish. Contact Albion for details.

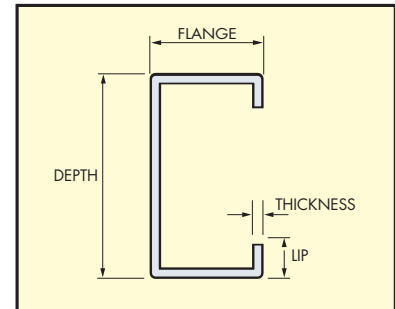

Zed section dimensions

SECTION REF	WEIGHT Kg/m	DEPTH mm	FLANGE mm	LIPS mm	THICKNESS mm
Z12515	2.80	120	50	15	1.5
Z12516	2.98	120	50	15	1.6
Z14613	3.06	145	62.5	20	1.3
Z14614	3.28	145	62.5	20	1.4
*Z14615	3.51	145	62.5	20	1.5
Z14616	3.73	145	62.5	20	1.6
Z14618	4.18	145	62.5	20	1.8
*Z14620	4.62	145	62.5	20	2.0
Z17613	3.36	175	62.5	20	1.3
Z17614	3.61	175	62.5	20	1.4
*Z17615	3.86	175	62.5	20	1.5
Z17616	4.11	175	62.5	20	1.6
Z17618	4.60	175	62.5	20	1.8
*Z17620	5.09	175	62.5	20	2.0
Z17623	5.81	175	62.5	20	2.3
Z17625	6.28	175	62.5	20	2.5
Z20613	3.67	200	65	20	1.3
Z20614	3.94	200	65	20	1.4
*Z20615	4.22	200	65	20	1.5
Z20616	4.49	200	65	20	1.6
Z20618	5.02	200	65	20	1.8
*Z20620	5.56	200	65	20	2.0
Z20623	6.35	200	65	20	2.3
Z20625	6.87	200	65	20	2.5
Z22614	4.22	225	65	20	1.4
Z22615	4.51	225	65	20	1.5
Z22616	4.80	225	65	20	1.6
Z22618	5.38	225	65	20	1.8
Z22620	5.95	225	65	20	2.0
Z22623	6.80	225	65	20	2.3
Z22625	7.36	225	65	20	2.5
Z24615	4.69	240	65	20	1.5
Z24616	4.99	240	65	20	1.6
Z24618	5.59	240	65	20	1.8
Z24620	6.19	240	65	20	2.0
Z24623	7.07	240	65	20	2.3
Z24625	7.65	240	65	20	2.5
Z24630	9.09	240	65	20	3.0
Z26616	5.30	265	65	20	1.6
Z26618	5.94	265	65	20	1.8
Z26620	6.58	265	65	20	2.0
Z26623	7.52	265	65	20	2.3
Z26625	8.14	265	65	20	2.5
Z26630	9.68	265	65	20	3.0
Z30718	6.72	300	75	20	1.8
Z30720	7.44	300	75	20	2.0
Z30723	8.51	300	75	20	2.3
Z30725	9.22	300	75	20	2.5
Z30730	10.97	300	75	20	3.0
Z34118	8.35	345	100	30	1.8
Z34120	9.25	345	100	30	2.0
Z34123	10.59	345	100	30	2.3
Z34125	11.48	345	100	30	2.5
Z34130	13.68	345	100	30	3.0
Z40120	10.11	400	100	30	2.0
Z40123	11.58	400	100	30	2.3
Z40125	12.56	400	100	30	2.5
Z40130	14.98	400	100	30	3.0
Z40132	15.94	400	100	30	3.2

C section dimensions

SECTION REF	WEIGHT Kg/m	DEPTH mm	FLANGE mm	LIPS mm	THICKNESS mm
C12515	2.80	120	50	15	1.5
C12516	2.98	120	50	15	1.6
C14613	3.06	145	62.5	20	1.3
C14614	3.28	145	62.5	20	1.4
*C14615	3.51	145	62.5	20	1.5
C14616	3.73	145	62.5	20	1.6
C14618	4.18	145	62.5	20	1.8
*C14620	4.62	145	62.5	20	2.0
C17613	3.36	175	62.5	20	1.3
C17614	3.61	175	62.5	20	1.4
*C17615	3.86	175	62.5	20	1.5
C17616	4.11	175	62.5	20	1.6
C17618	4.60	175	62.5	20	1.8
*C17620	5.09	175	62.5	20	2.0
C17623	5.81	175	62.5	20	2.3
C17625	6.28	175	62.5	20	2.5
C20613	3.67	200	65	20	1.3
C20614	3.94	200	65	20	1.4
*C20615	4.22	200	65	20	1.5
C20616	4.49	200	65	20	1.6
C20618	5.02	200	65	20	1.8
*C20620	5.56	200	65	20	2.0
C20623	6.35	200	65	20	2.3
C20625	6.87	200	65	20	2.5
C22614	4.22	225	65	20	1.4
C22615	4.51	225	65	20	1.5
C22616	4.80	225	65	20	1.6
C22618	5.38	225	65	20	1.8
C22620	5.95	225	65	20	2.0
C22623	6.80	225	65	20	2.3
C22625	7.36	225	65	20	2.5
C24615	4.69	240	65	20	1.5
C24616	4.99	240	65	20	1.6
C24618	5.59	240	65	20	1.8
C24620	6.19	240	65	20	2.0
C24623	7.07	240	65	20	2.3
C24625	7.65	240	65	20	2.5
C24630	9.09	240	65	20	3.0
C26616	5.30	265	65	20	1.6
C26618	5.94	265	65	20	1.8
C26620	6.58	265	65	20	2.0
C26623	7.52	265	65	20	2.3
C26625	8.14	265	65	20	2.5
C26630	9.68	265	65	20	3.0
C30718	6.72	300	75	20	1.8
C30720	7.44	300	75	20	2.0
C30723	8.51	300	75	20	2.3
C30725	9.22	300	75	20	2.5
C30730	10.97	300	75	20	3.0
C34118	8.35	345	100	30	1.8
C34120	9.25	345	100	30	2.0
C34123	10.59	345	100	30	2.3
C34125	11.48	345	100	30	2.5
C34130	13.68	345	100	30	3.0
C40120	10.11	400	100	30	2.0
C40123	11.58	400	100	30	2.3
C40125	12.56	400	100	30	2.5
C40130	14.98	400	100	30	3.0
C40132	15.94	400	100	30	3.2

Albion Sections eaves beams have been designed symmetrically so that they can be used in many different situations. They can be effectively used as gutter supports, parapet rails, fixed in pairs as compound beams or valley beams, column ties and wall restraints.

dimensions of eaves beams

SECTION REF	WEIGHT Kg/m	a mm	b mm	t mm
EB20018	6.38	200	45	1.80
*EB20020	7.03	200	45	2.00
EB20025	8.64	200	45	2.50
EB20030	10.17	200	45	3.00
EB24020	7.66	240	65	2.00
EB24025	9.42	240	65	2.50
EB24030	11.12	240	65	3.00
EB30020	8.76	300	75	2.00
EB30025	10.79	300	75	2.50
EB30030	12.76	300	75	3.00

* EB20020 is available with 'Polycoat' or Z600 galvanised finish. Contact Albion for details.

Using the Albion Eaves Beam avoids the need for counterformed holes and packing plates.

Albion Tip

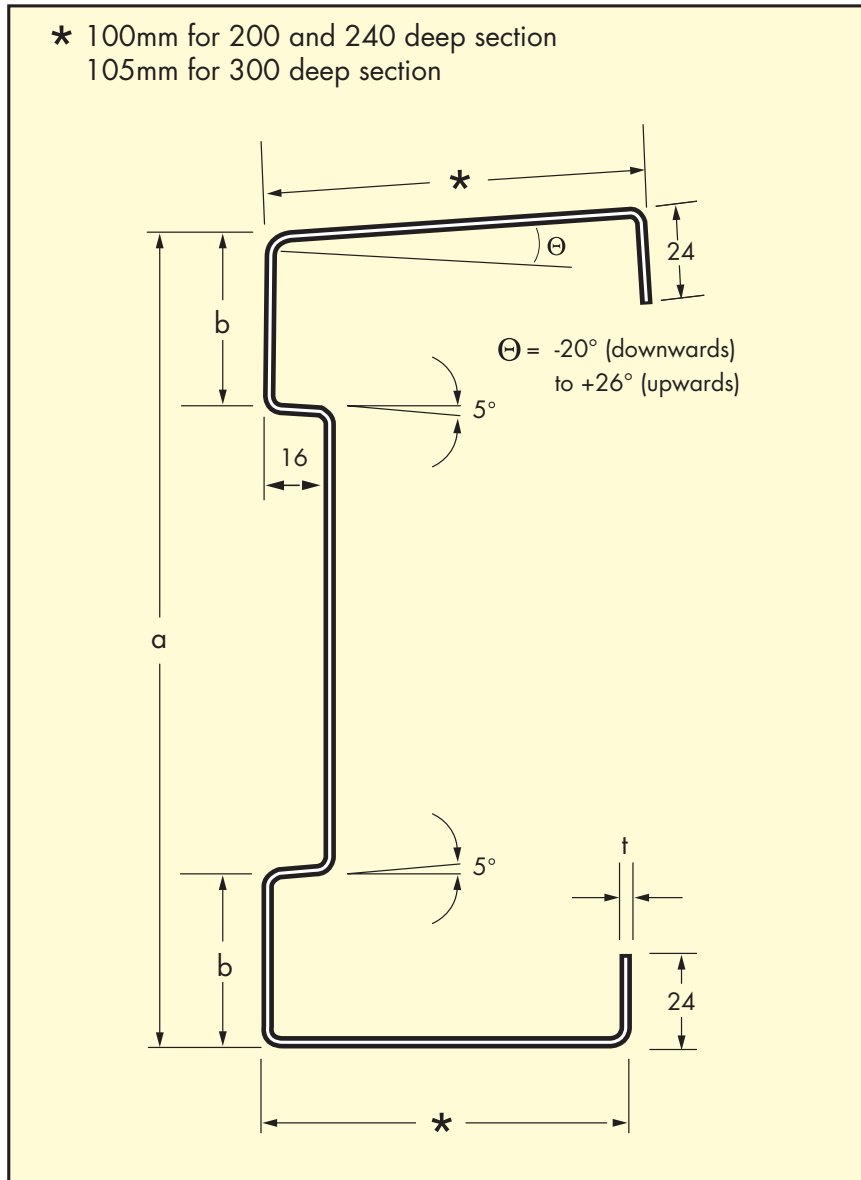

section profile

zed and channel sections

Z or C SECTION REF	DEPTH mm	SECTION WT. Kg/m	Z STD SLEEVE WT. Kg each	HEB SYSTEM		C STD SLEEVE WT. Kg each
				INNER BAY	END BAY	
12515	120	2.80	1.13			1.0
12516	120	2.98	1.20			1.1
14613	145	3.06	1.20	1.80	2.29	1.5
14614	145	3.28	1.29	1.93	2.46	1.7
14615	145	3.51	1.38	2.06	2.63	1.8
14616	145	3.73	1.47	2.19	2.79	1.9
14618	145	4.18	1.64	2.45	3.12	2.1
14620	145	4.62	1.82	2.71	3.45	2.3
17613	175	3.36	2.00	2.32	3.13	2.2
17614	175	3.61	2.14	2.49	3.37	2.4
17615	175	3.86	2.29	2.66	3.60	2.5
17616	175	4.11	2.44	2.83	3.83	2.7
17618	175	4.60	2.73	3.17	4.28	3.0
17620	175	5.09	3.02	3.50	4.73	3.4
17623	175	5.81	3.44	4.00	5.40	3.9
17625	175	6.28	3.72	4.32	5.84	4.2
20613	200	3.67	2.19	3.13	4.06	2.4
20614	200	3.94	2.35	3.36	4.36	2.6
20615	200	4.22	2.52	3.59	4.66	2.8
20616	200	4.49	2.68	3.82	4.96	3.0
20618	200	5.02	3.00	4.28	5.56	3.4
20620	200	5.56	3.31	4.73	6.15	3.7
20623	200	6.35	3.78	5.40	7.02	4.3
20625	200	6.87	4.09	5.84	7.59	4.6
22614	225	4.22	2.53	3.61	4.69	3.5
22615	225	4.51	2.70	3.86	5.01	3.7
22616	225	4.80	2.88	4.10	5.33	4.0
22618	225	5.38	3.22	4.60	5.97	4.4
22620	225	5.95	3.56	5.08	6.61	4.9
22623	225	6.80	4.07	5.81	7.55	5.6
22625	225	7.36	4.40	6.28	8.17	6.1
24615	240	4.69	3.26	4.36	5.84	4.2
24616	240	4.99	3.47	4.64	6.22	4.5
24618	240	5.59	3.88	5.20	6.96	5.0
24620	240	6.19	4.30	5.75	7.70	5.6
24623	240	7.07	4.91	6.58	8.80	6.4
24625	240	7.65	5.32	7.12	9.53	6.9
24630	240	9.09	6.31	8.45	11.31	8.3
26616	265	5.30	4.76	5.10	7.44	5.3
26618	265	5.94	5.33	5.72	8.33	6.0
26620	265	6.58	5.90	6.33	9.22	6.6
26623	265	7.52	6.75	7.23	10.54	7.6
26625	265	8.14	7.30	7.83	11.41	8.2
26630	265	9.68	8.67	9.30	13.55	9.8
30718	300	6.72	6.87	7.89	10.74	6.7
30720	300	7.44	7.61	8.74	11.89	7.4
30723	300	8.51	8.70	10.00	13.60	8.5
30725	300	9.22	9.42	10.83	14.73	9.3
30730	300	10.97	11.21	12.89	17.53	11.1
34118	345	8.35	9.43	10.93	14.81	8.3
34120	345	9.25	10.44	12.11	16.41	9.2
34123	345	10.59	11.96	13.87	18.79	10.6
34125	345	11.48	12.96	15.03	20.37	11.5
34130	345	13.68	15.44	17.91	24.27	13.7
40120	400	10.11	13.63	15.57	21.41	13.5
40123	400	11.58	15.61	17.84	24.53	15.5
40125	400	12.56	16.92	19.34	26.60	16.9
40130	400	14.98	20.18	23.06	31.71	20.2
40132	400	15.94	21.47	24.53	33.73	21.5

eaves beam

SECTION REF	DEPTH mm	WEIGHT Kg/m
EB20018	200	6.38
EB20020	200	7.03
EB20025	200	8.64
EB20030	200	10.17
EB24020	240	7.66
EB24025	240	9.42
EB24030	240	11.12
EB30020	300	8.76
EB30025	300	10.79
EB30030	300	12.76

purlin/rail cleats

TO SUIT DEPTH	FLAT Kg/ each	ANGLE Kg/each
120	0.71	1.10
145	0.79	1.18
175	0.96	1.35
200	1.09	1.48
225	1.16	1.55
240	1.73	2.24
265	2.36	2.97
300	2.68	3.30
345	3.11	3.72
400	3.63	4.24

accessories

	WEIGHT Kg/m
side rail supports	1.6
eaves struts	1.6
speed fix anti sag rods	0.5
diagonal tie wires	0.1 + (0.8Kg end cleats)
cleader angle 45x45x2	1.34
cleader angle 75x75x2	2.30
rafter/column stays	1.34
M12 all thread	0.71

Albion product range

SECTIONS

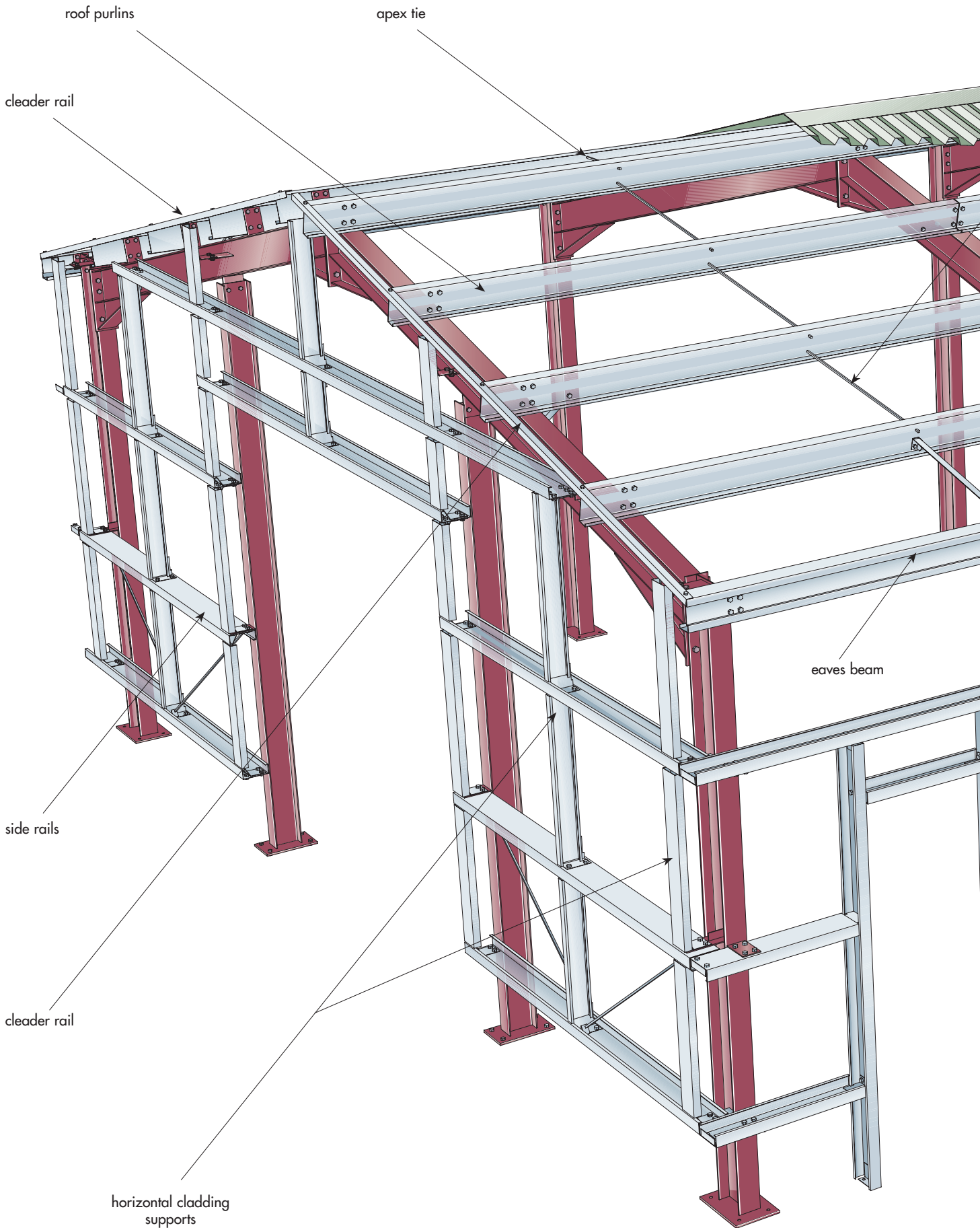

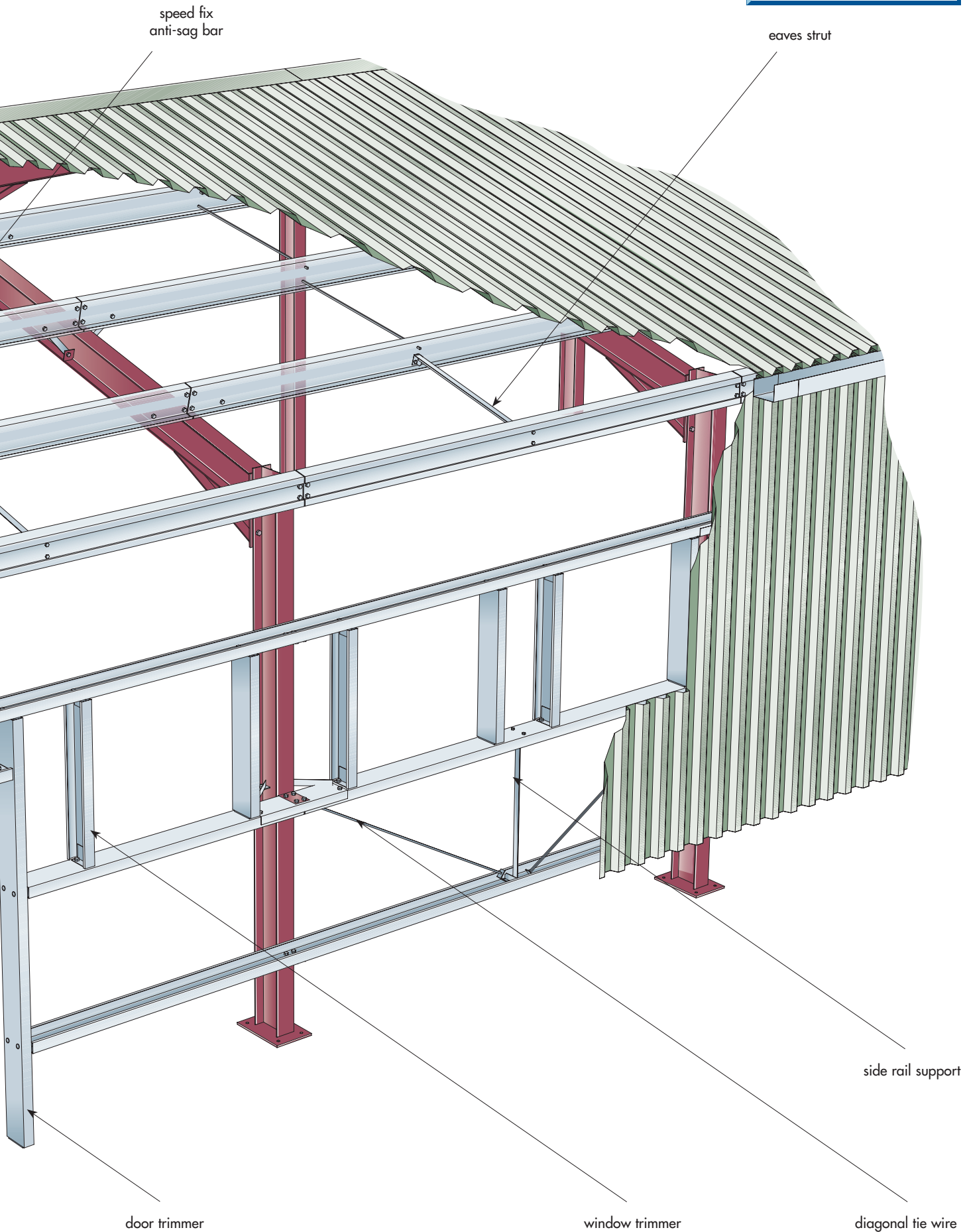

connections

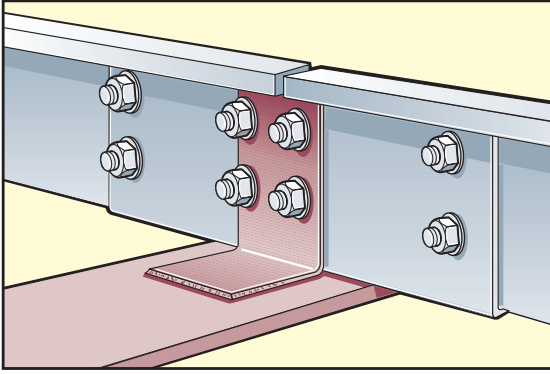

sleeved connection

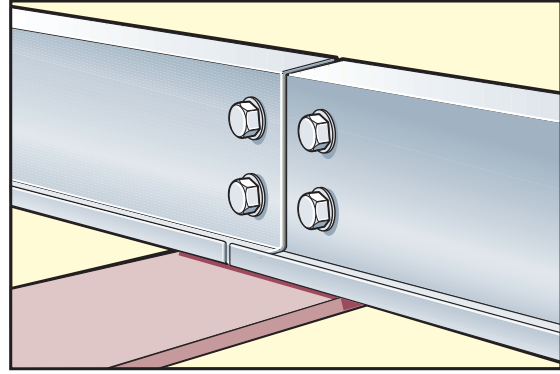

butted connection

system & jointing layouts

Note: That in both sleeve systems, sleeves are provided to all purlins on the penultimate rafter

sleeved system (purlins & rails)

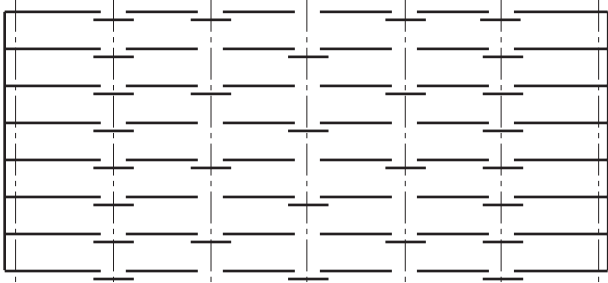

single span with staggered sleeve arrangement

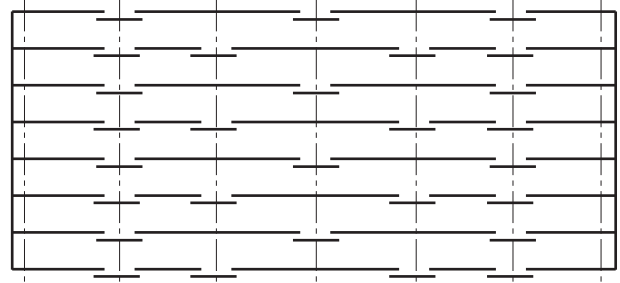

single/double span with staggered sleeve arrangement

The sleeved system is the most popular and widely specified system for buildings of 2 bays or more.

It provides a cost effective solution combined with ease of detailing to many building designs.

double span butt joint system (purlins & rails)

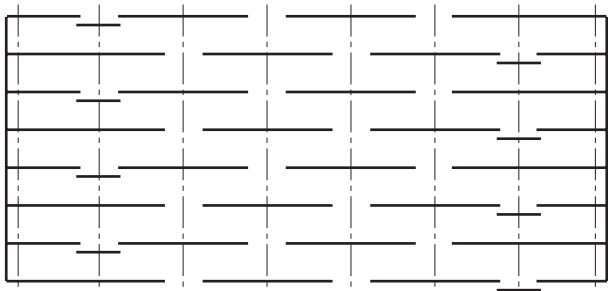

The double span butt joint system is not as efficient in load carrying capacity when compared to the sleeved system, however, when load criteria allows choice of system then this is the more cost effective, saving on component parts and site erection time.

single span butted system (purlins & rails)

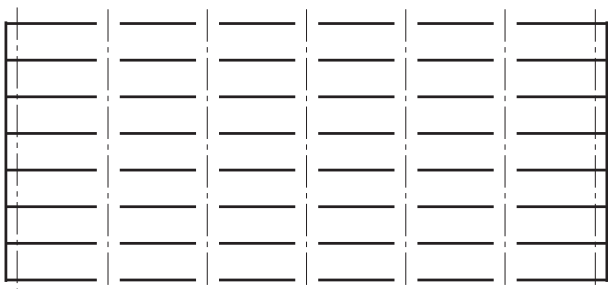

The single span butted purlin/rail (non continuous system) is the most simple of all the systems. Used generally for shorter spans or where lighter loads apply as in agricultural buildings. It is economical, easily detailed and purlins can be fitted either over the rafters or between the rafter webs.

heavy end bay system & jointing layouts (purlins only)

All end bay purlins single span.
Inner bay purlins single span or double span.
All joints to be fully sleeved.

typical sleeving arrangement

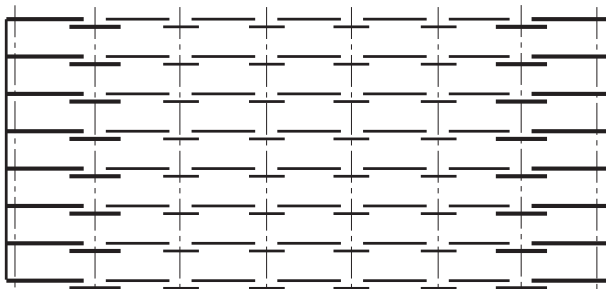
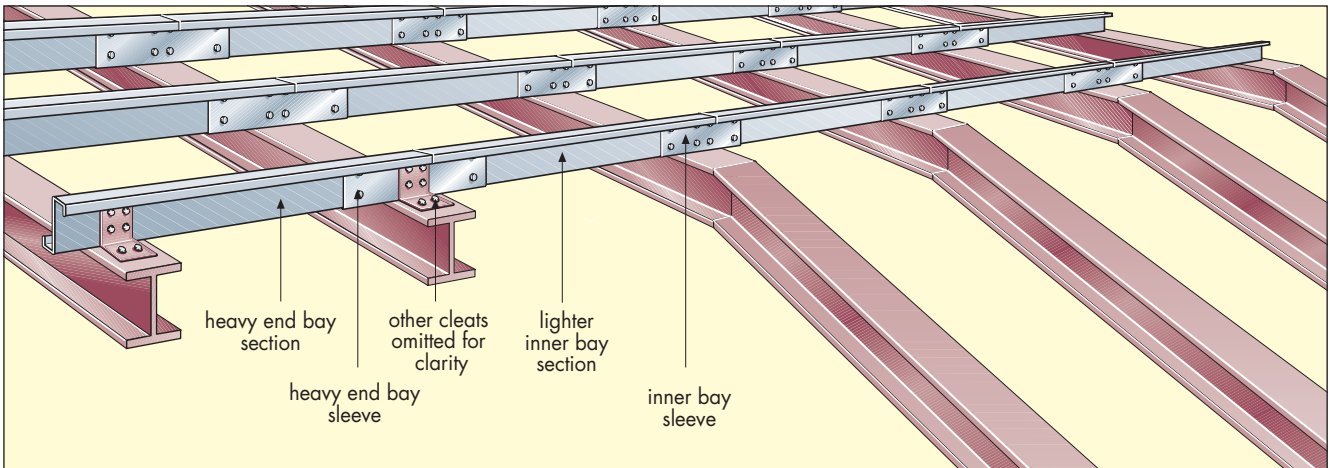

all purlins single span

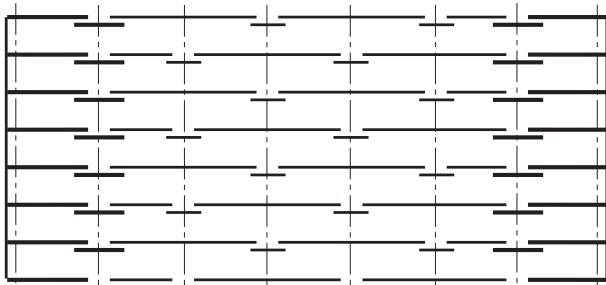

inner bay purlins double span

The heavy end bay system offers an economic solution to the larger and multispan type building, with the inner bays being of a lighter gauge material.

The system caters for spans up to 15m dependant on loading criteria, and is a fully continuous purlin system, with sleeves at every joint.

The penultimate rafter is sleeved with a longer sleeve of a heavier gauge equal to the end bay purlins to cater for the higher moments in the end bay. The inner bay sleeves are slightly longer than standard sleeves with double hole punchings for sleeve connection, and are of the same lighter gauge as intermediate purlins.

For the system to perform economically only buildings with a minimum of five bays should be considered.

The heavy end bay system can also be supplied with the inner bay purlins double spanning with single span purlins introduced to stagger the rigid joints; as shown in the diagram.

Note: Rigid joint of double span purlins can be in line but rafters need to be checked for extra stress.

If in any doubt of any system please contact our technical design department

zed purlins/side rails

Holes and dimensions for typical single span sleeved purlins and rails with central sag bar holes.

Butted purlins and rails are identical except only two bolt end connections required. Purlins and rails are available up to 16 meters maximum, but it is recommended that because of transportation and handling, 120 and 145 series be limited to 10m maximum.

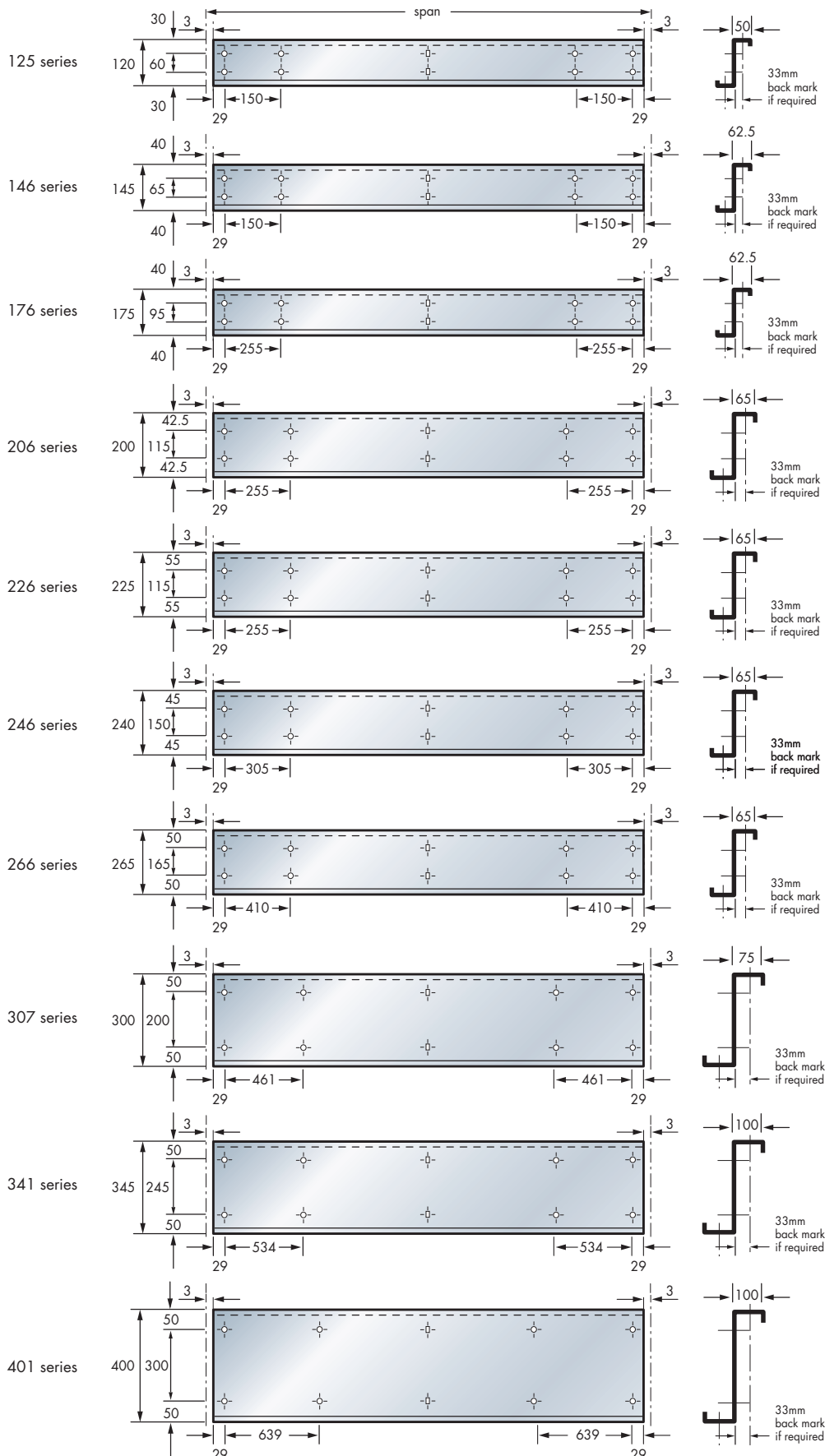

Purlin and rail assembly bolts:-
For Sections up to and including 246 series either M12 grade 8.8 or M16 grade 4.6 may be used. Sections 266 series and above M16 grade 4.6 only.
Holes 14mm for M12 bolts and 18mm for M16 bolts.

Clearance between purlins and rails at joints is 6mm. All sag rod and side rail support holes are rectangular 20mm x 14mm top and bottom. Flange holes 14mm diameter at backmark shown. Facility to offer firewall slots, counter formed holes (18mm diameter only).

zed purlin sleeves

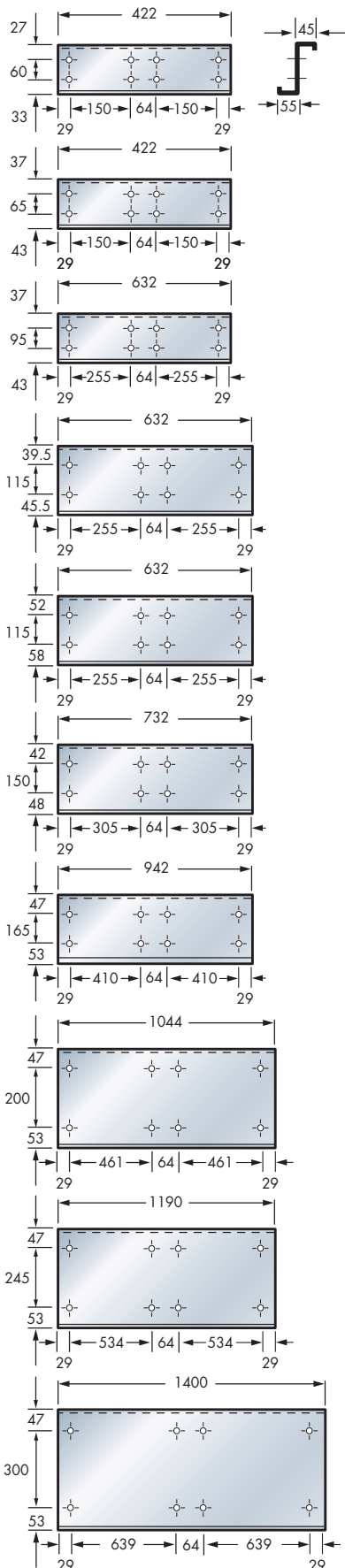

end bay heavy gauge

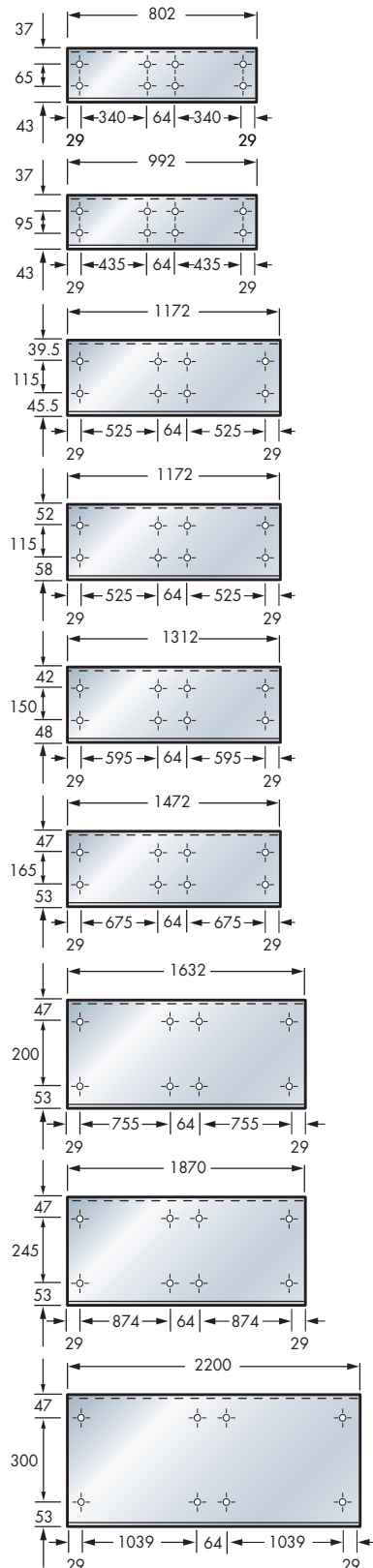

inner bay lighter gauge

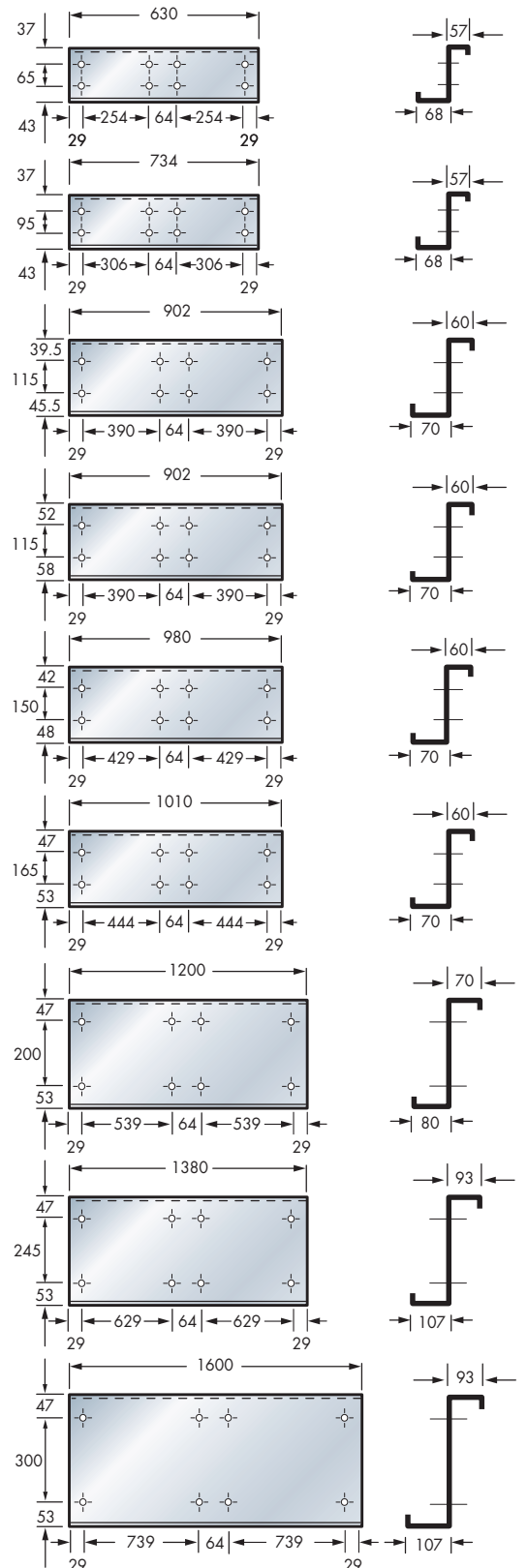

Sag rod holes:

Purlins at mid, $\frac{3}{8}$ and $\frac{5}{8}$ span as required
 Rails at mid or third points as required

Holes and dimensions for standard single bay spanning channel sections, double bay spanning channel sections available up to a maximum of 16m overall length. Flange holes are 14mm diameter. All holes on standard gauge lines. Facility to offer firewall slots and counter formed holes (18mm diameter only).

All sag rod and side rail support holes are rectangular 20mm x 14mm top and bottom to suit M12 bolts.

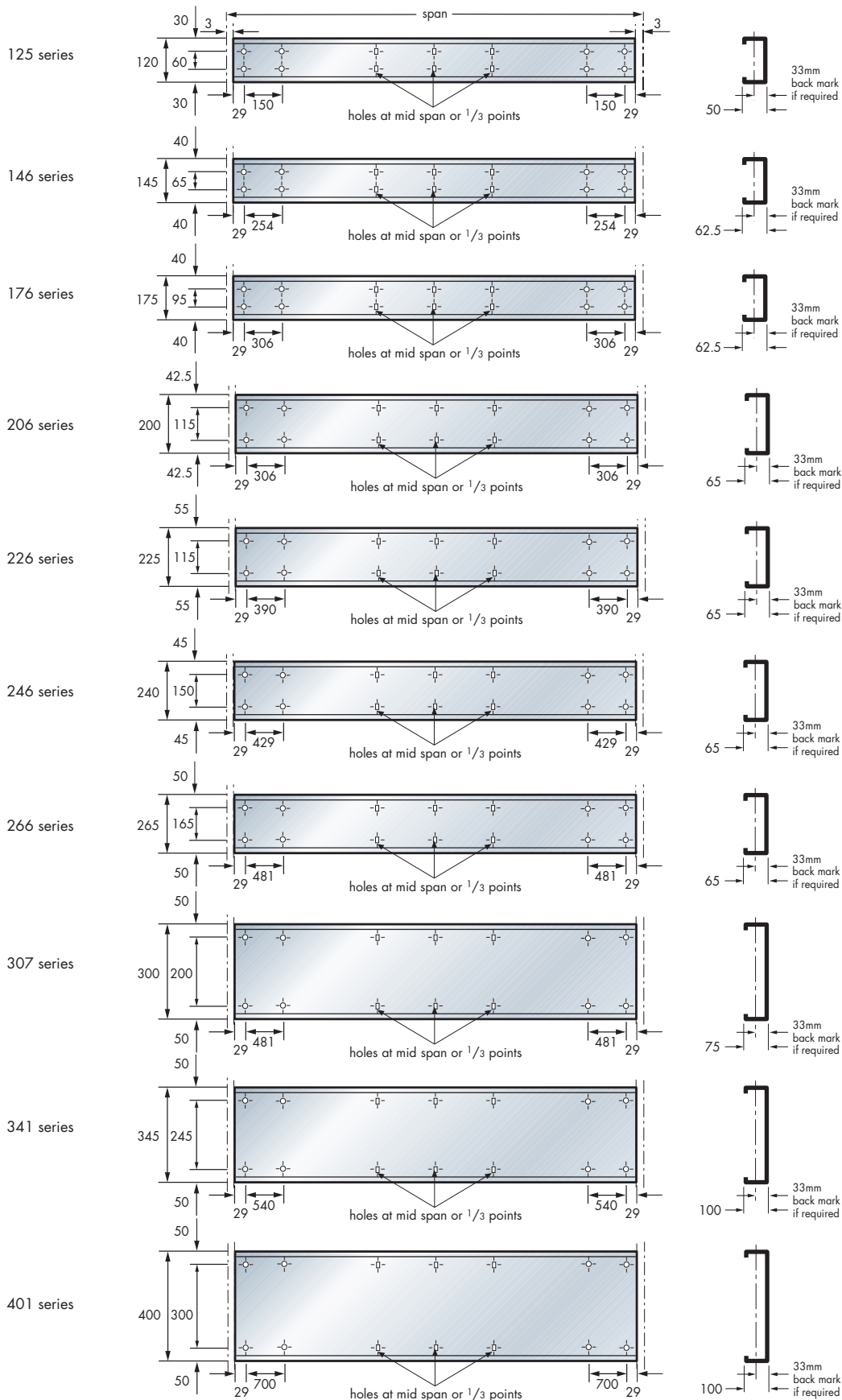

Purlin and rail assembly bolts:-

For Sections up to and including 246 series either M12 grade 8.8 or M16 grade 4.6 may be used. Sections 266 series and above M16 grade 4.6 only.

Holes 14mm for M12 bolts and 18mm for M16 bolts.

C sleeve details

cleats to suit zed and channel sections (see also page 15)

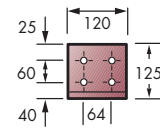
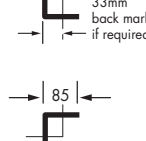
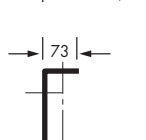
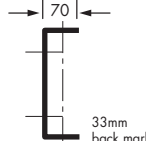
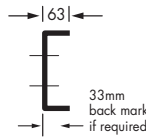
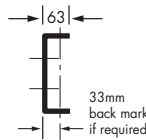
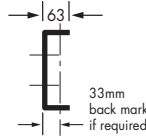
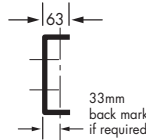
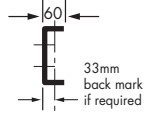
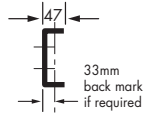
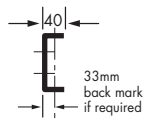
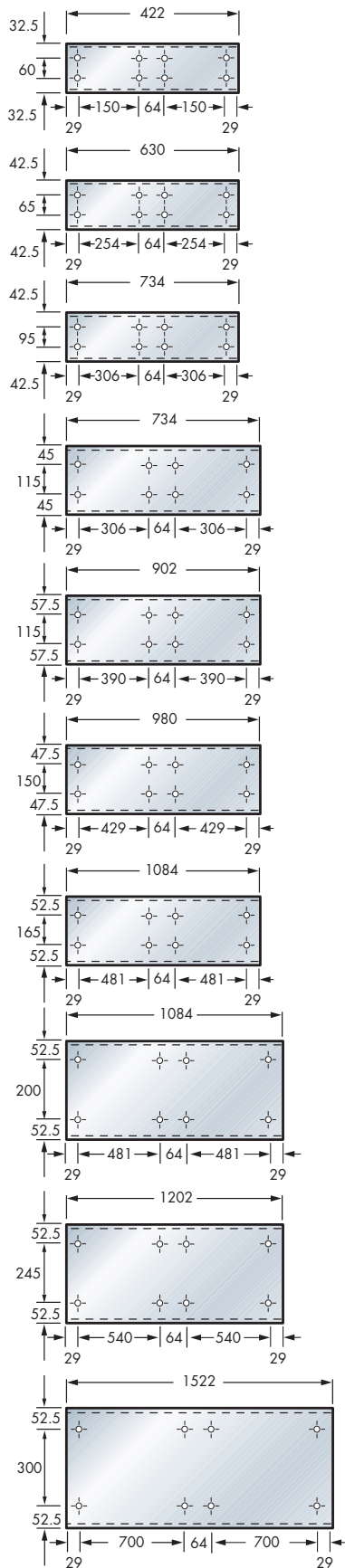

125 series

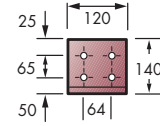

146 series

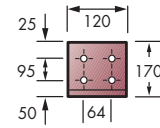

176 series

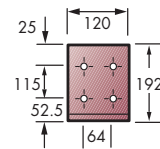

206 series

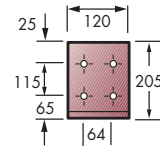

226 series

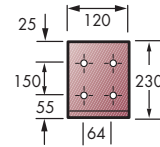

246 series

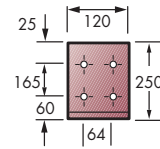

266 series

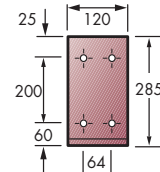

307 series

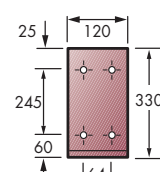

341 series

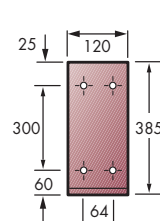

401 series

standard dimensions

Holes and dimensions for eaves beams.

All web holes 18mm dia. for 16mm dia. bolts.

Clearance between eaves beams at joints is 6mm.

Top flanges may be angled from -20° (downwards) to 26.5° (upwards).

Maximum length of section is 15m.

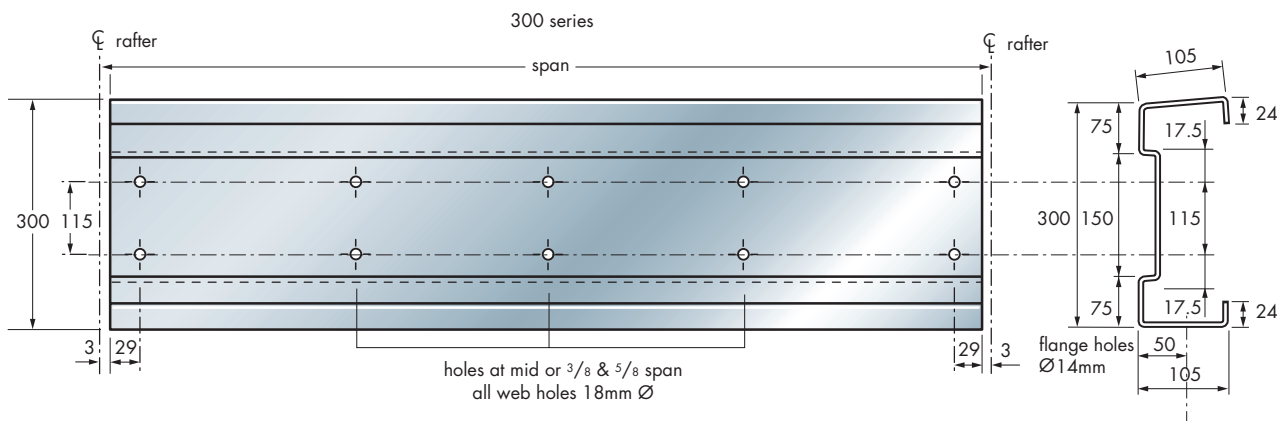
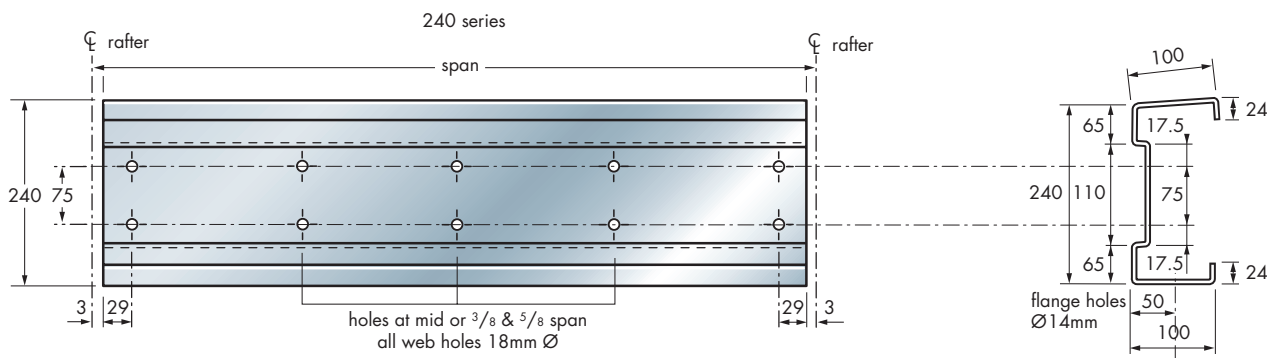
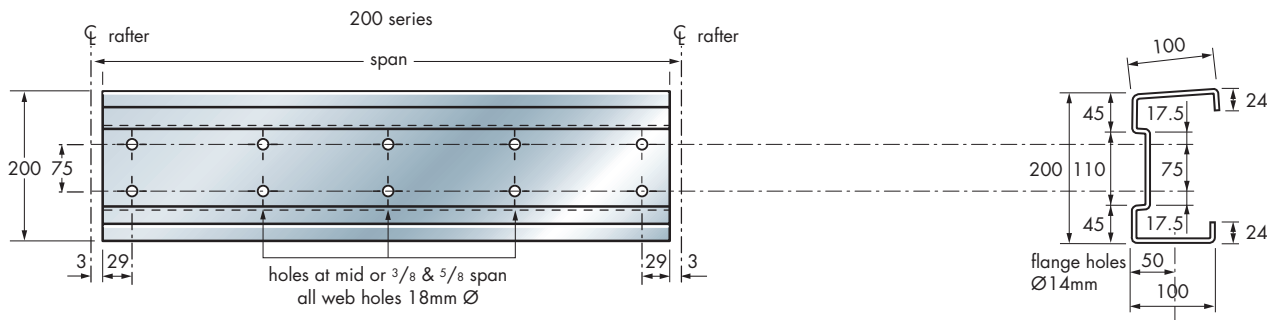

cleats

weld-on cleat

Section Ref	A mm	B mm	C mm	t mm
C & Z 125	60	40	125	6
C & Z 146	65	50	140	6
C & Z 176	95	50	170	6
C & Z 206	115	52.5	192	6
C & Z 226	115	65	205	6

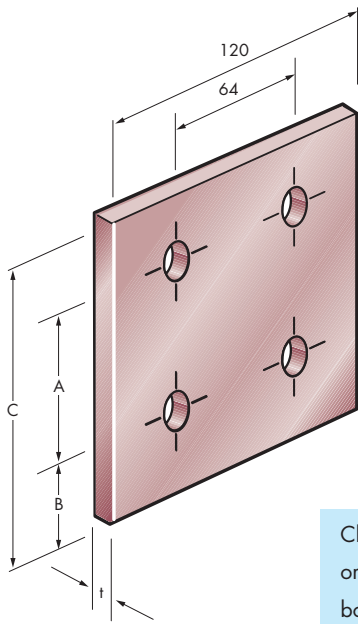

Cleats up to 246 series 14mm or 18mm holes dependant on bolt choice (see pages 10 & 12).
Cleats 266 series and above 18mm holes.

weld/bolt-on cleat

Section Ref	A mm	B mm	C mm	t mm
C & Z 125	60	40	125	6
C & Z 146	65	50	140	6
C & Z 176	95	50	170	6
C & Z 206	115	52.5	192	6
C & Z 226	115	65	205	6
C & Z 246	150	55	230	8
C & Z 266	165	60	250	10
C & Z 307	200	60	285	10
C & Z 341	245	60	330	10
C & Z 401	300	60	385	10

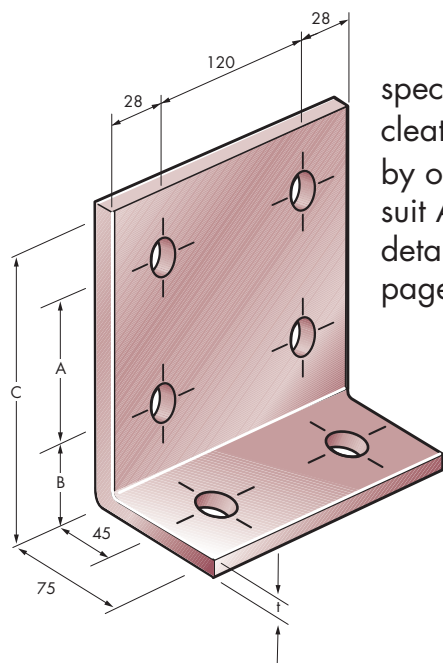
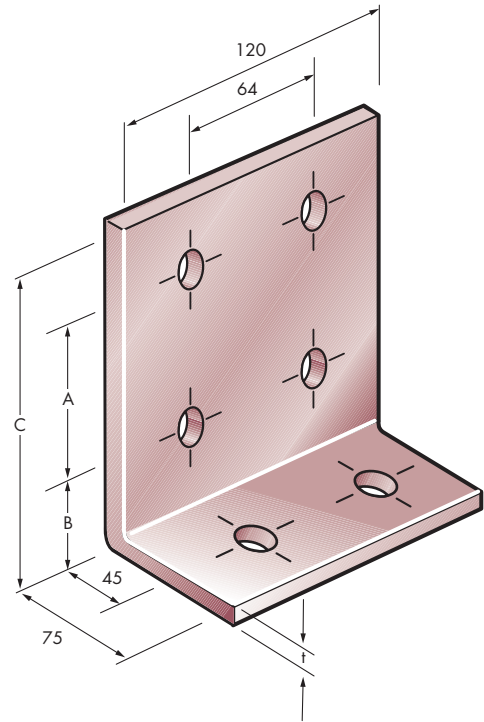

special fire wall cleat supplied by others (and to suit Albion Firewall details see page 26)

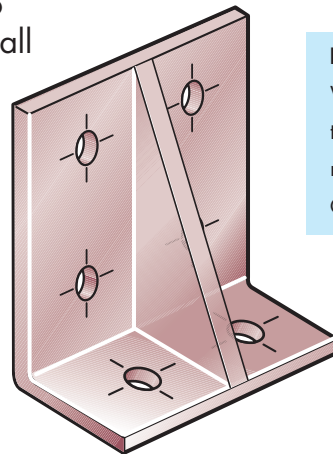

stiffened cleat supplied by others

Note:

Where long spans/abnormal loads in tiled roofs or steep slopes purlin cleats may require stiffening. Consult our Technical Department.

mono pitched roof

typical mono pitched roof layout
side elevation

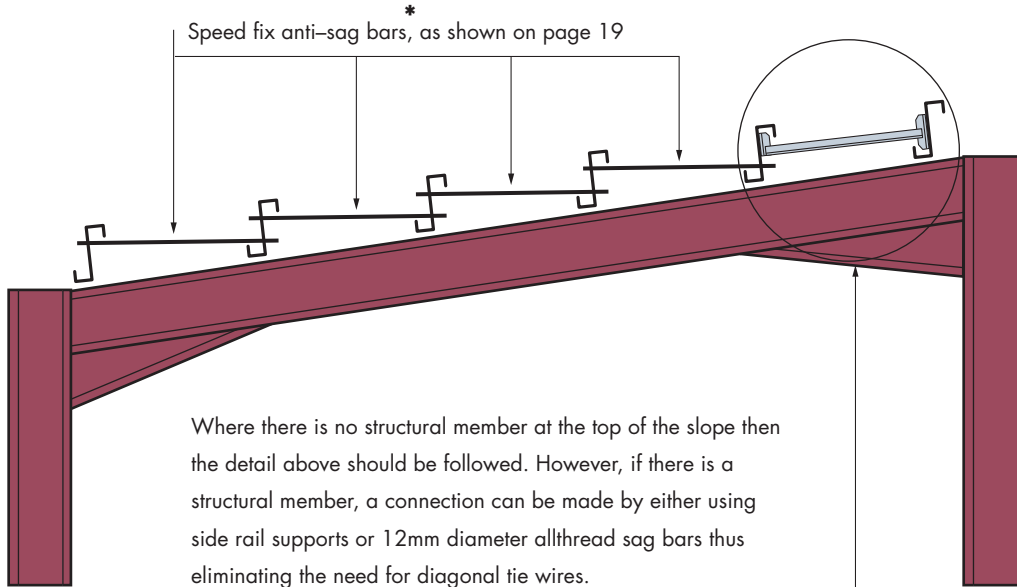

* Use side rail struts for sections 300 to 400 deep

roof plan

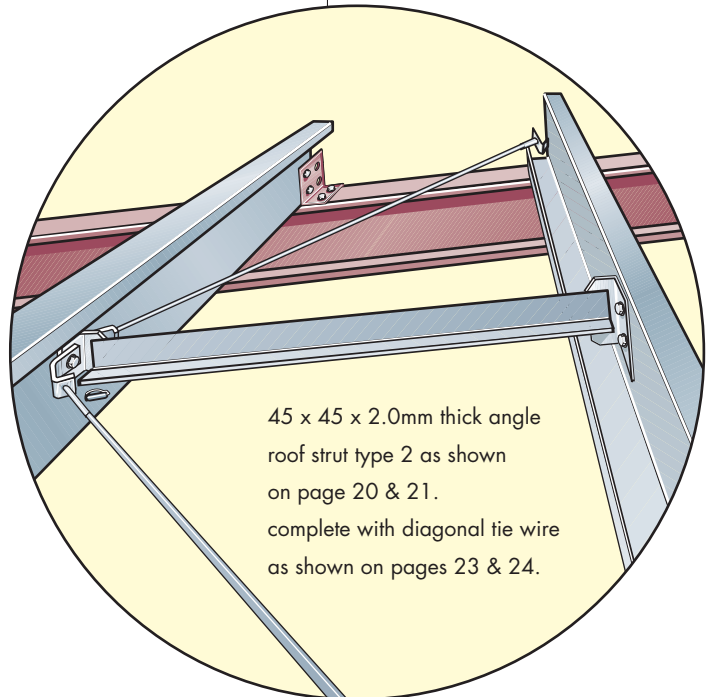
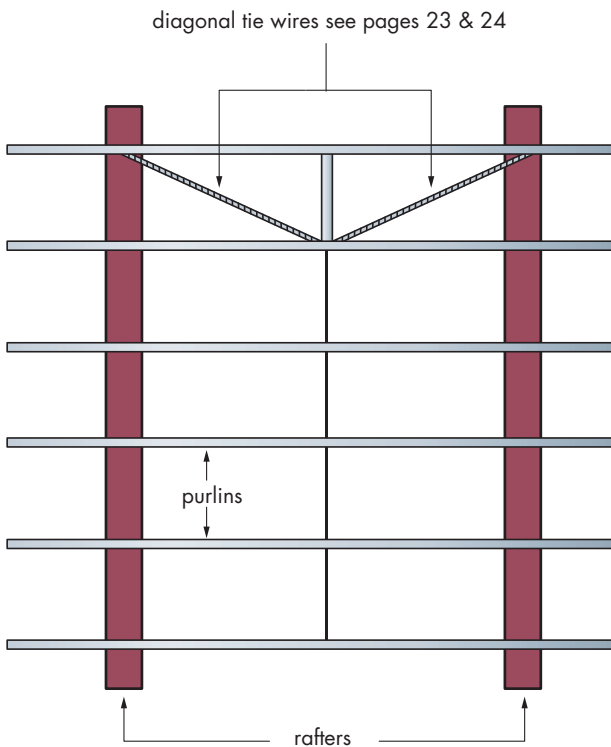

Diagonal tie wire brackets, one bracket fixed between purlin and lateral support cleat, other bracket fixed on top of lateral support cleat.

Note: Where span exceeds 7.6m supports are at $\frac{3}{8}$ & $\frac{5}{8}$ points and not as shown.
For spans in excess of 9m contact our Technical Department.

Note: Ensure 5mm bracket thickness is deducted from length of lateral support.

tiled roof

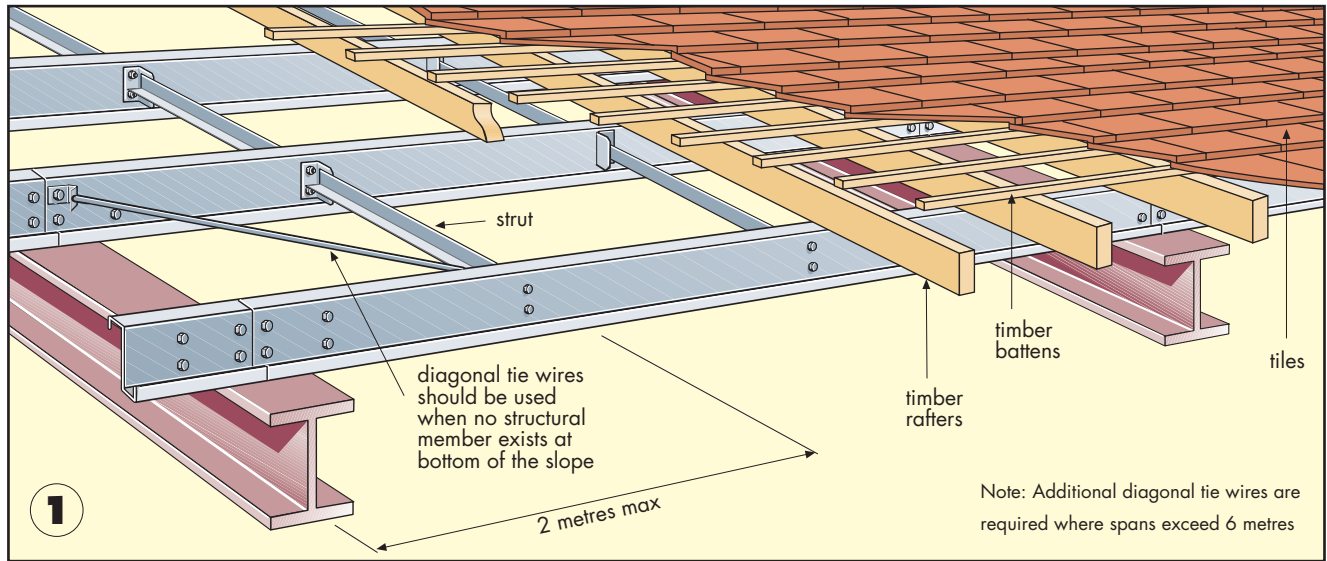

Diagrams 2,3 & 4: typical examples of fixing battens to the purlins.

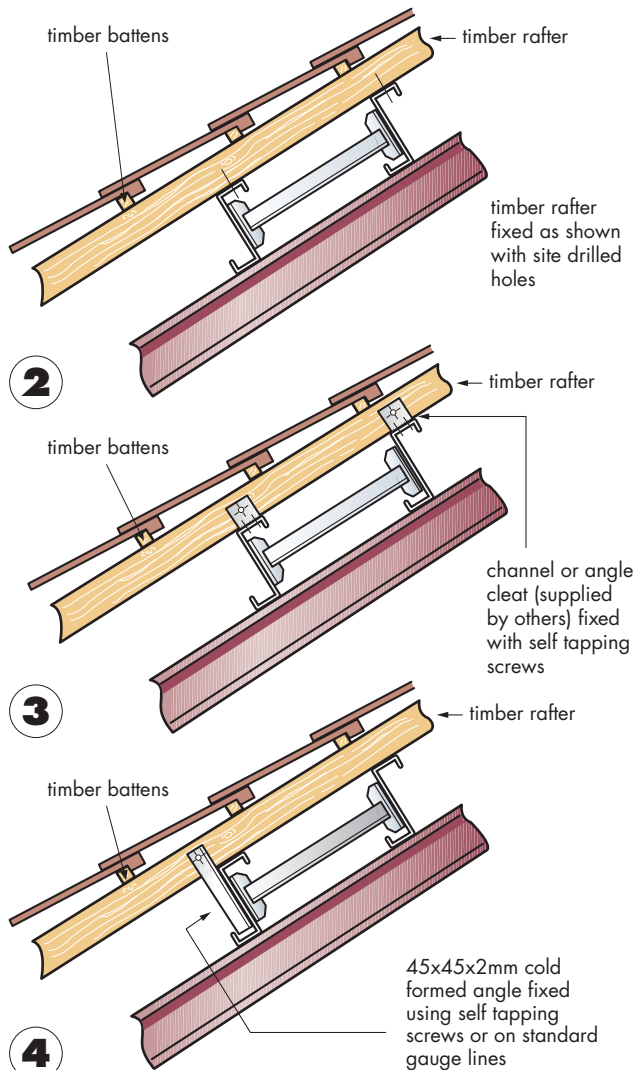

The use of traditional tiled roof construction on steel framed buildings is becoming increasingly popular. Typical examples of this are new supermarkets which are required to blend into an existing townscape.

However due to the high rotational forces imposed on the purlins caused by the high load and steep slope factors normally encountered in roofs of this type, it is essential that adequate restraining methods are employed. This can be achieved by adopting the layout shown in diagram 1 and the following points be adhered to.

1. Side rail support type struts are fixed between the purlins with a maximum unrestrained length of 2m. For spans in excess of 6m contact our Technical Department for tie wire arrangement.
2. At the bottom of the slope the struts should be fixed back to a structural member. Where no structural member exists then diagonal tie wires should be used as shown in diagram 1.
3. The maximum length of slope unsupported via diagonal tie wires or structural member should not exceed 5.4m.
4. Rigid type restraints are continued over the apex.

Note:

Provided the rafters are spaced at no more than 600mm centres along the purlin length the load may be assumed to be uniformly distributed.

When tiles/battens incorporate a steel deck which is screw fixed to purlins contact our technical department for restraint details.

Deflection should be taken into consideration to prevent tiles lifting, check with tile manufacturer, and recommend that deflection ratio is limited to span/250 in a vertical plain.

purlins with non-restraining cladding

With the increase in secret fix standing seam roofing systems which do not give lateral restraint to the top flange of the purlins it is necessary to introduce the use of lateral supports. The lateral supports are the same as the side rail supports shown on page 21 with specials manufactured at the apex to suit the required roof slope and centres.

Provided the unrestrained purlin length does not exceed 2 metres, the standard relevant load tables can be used i.e. sleeved, single span, double span, or heavy end bay.

Where liner panels are used and fixed directly to the top flange of the purlins and are a strong enough section to provide lateral restraint then standard sag bars can be used if required.

If in any doubt contact our technical department.

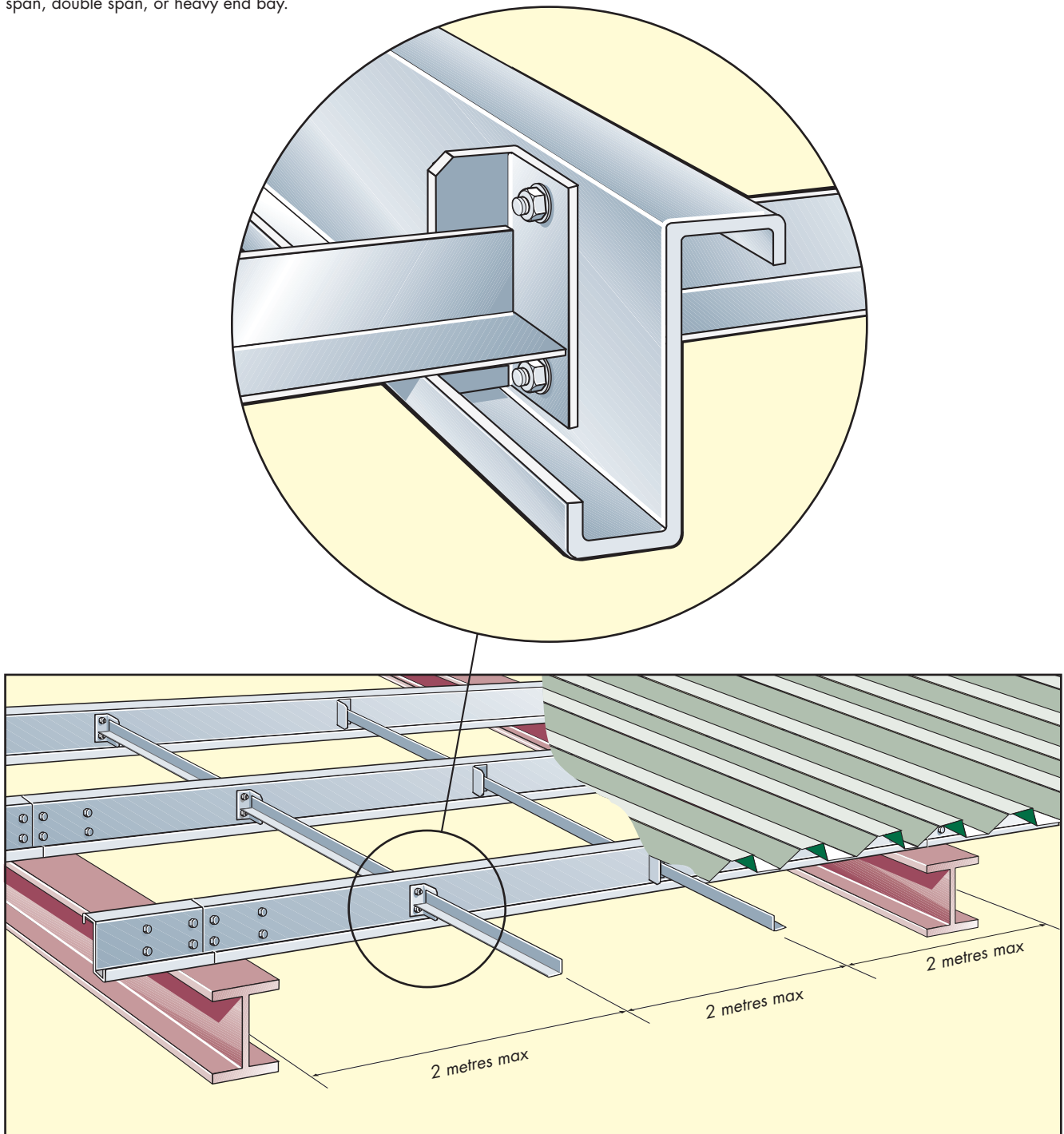

anti-sag rods (sections 125 - 266 series)

speed fix anti-sag bars

Speed fix anti-sag bars and apex ties are manufactured from 1.6mm thickness pre-hot dipped galvanised mild steel and cold roll formed into a channel section. Each end is notched to locate in the standard pre-punched holes at mid or $\frac{3}{8}$ ths & $\frac{5}{8}$ ths span and held in position with a spring. Alternative apex ties are manufactured from 12mm diameter allthread zinc plated finish.

anti-sag bars serve two main purposes:

- To stop the purlin twisting during erection. (once sheeting is fixed the purlin derives a large measure of stiffness from the roof membrane).
- To provide lateral restraint to the bottom flange under uplift conditions.

for roof slopes of 10° or more

The purlin tries to roll backwards. This is prevented by fixing anti-sag bars bottom hole to top hole down the slope as shown.

Note: These details apply to roof slopes up to and including 25°. For roof slopes greater than 25° consult our Technical Department.

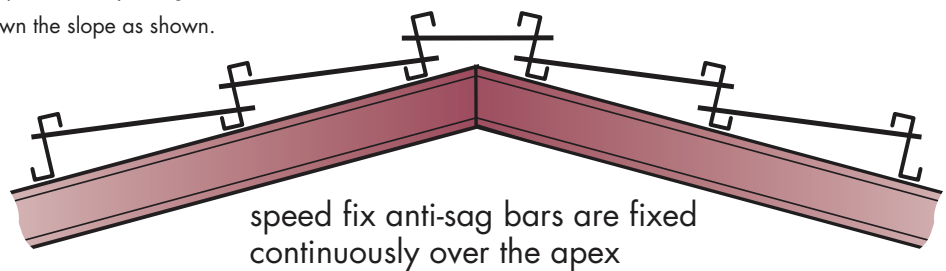

for roof slopes of 1.5° to 10°

The purlin tries to roll forwards. Anti-sag bars should be fitted top hole to bottom hole down the slope as shown.

Note: For sections 300mm deep and over 45mm x 45mm x 2mm angle struts should be used in lieu of speed fix sag rods.

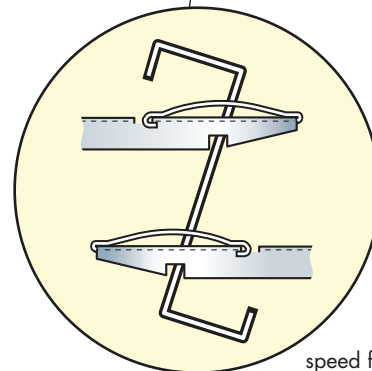
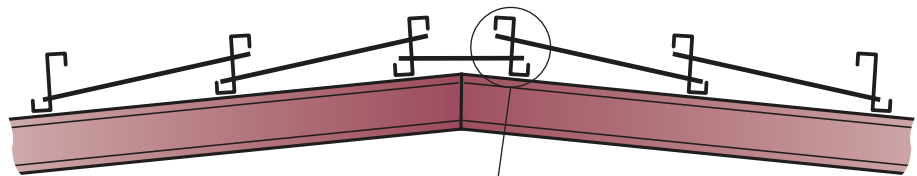

speed fix detail

for roof slopes up to 1.5°

For pitches at this level conventional anti-sag bars become ineffective and therefore speed fix anti-sag bars should be replaced with our side rail supports. We recommend that purlins are fixed as opposing pairs and the side rail supports fixed between the pairs.

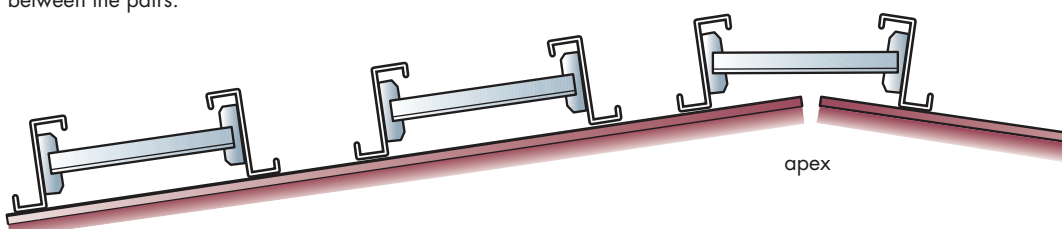

long roof slopes

For roof slopes in excess of 20m it is recommended that additional supports are fitted along the roof slope in the form of diagonal tie wires and side rail supports to reduce the down slope loading.

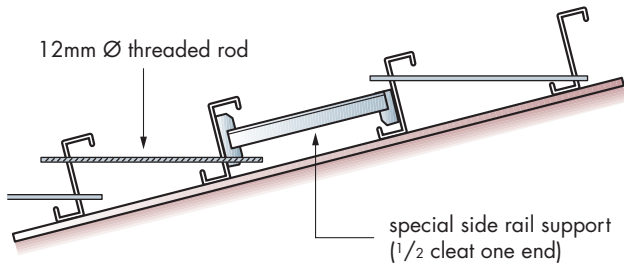

For 300mm to 400mm deep sections replace threaded rod and anti-sag bars with side rail struts.

The maximum span without anti-sag rods (or angle struts 300mm to 400mm deep sections) is as shown in the table opposite.

If no anti-sag bar or struts are provided temporary propping may be required during the roof cladding operation (by others).

Wind uplift loading may however be critical - refer to wind uplift tables.

typical bay plan

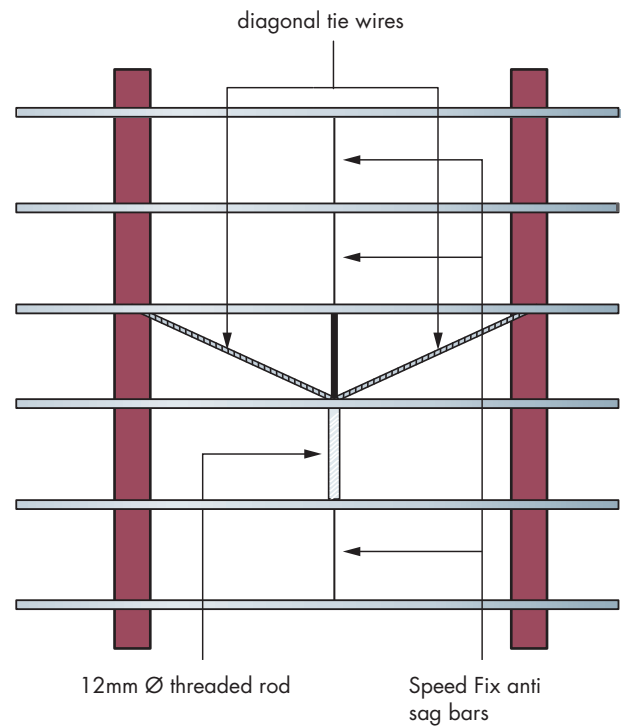

maximum span without anti sag bars:

Purlin Ref	Span
125	5.5m
146	6.1m
176	6.5m
207,227	7.0m
247, 267, 307, 341, 401	7.5m

side rail supports/eaves struts

Side rail supports are manufactured from pre-hot dipped galvanized mild steel and cold roll formed into an angle section 45 x 45 x 2.0mm thick.

Only side rail supports fabricated as shown will give the necessary stability under wind pressure or suction loads.

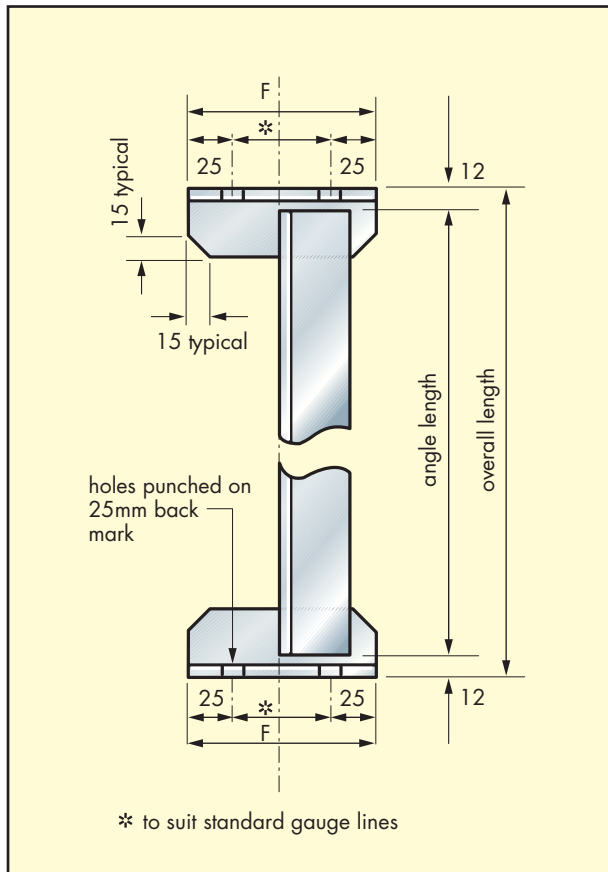

standard gauge line details

Section Ref	Standard Gauge Line Centres * mm	Dim F mm
125	60	110
146	65	115
176	95	145
206	115	165
226	115	165
246	150	200
266	165	215
307	200	250
341	245	295
401	300	350

Note:

When side rail supports are used in conjunction with diagonal tie wires at a mid point location (see page 23) the actual overall length will be rail centres less 7mm. For side rail supports used at intermediate and third point location (see page 24) the actual overall length will be rail centres less thickness of rail.

end cleat types

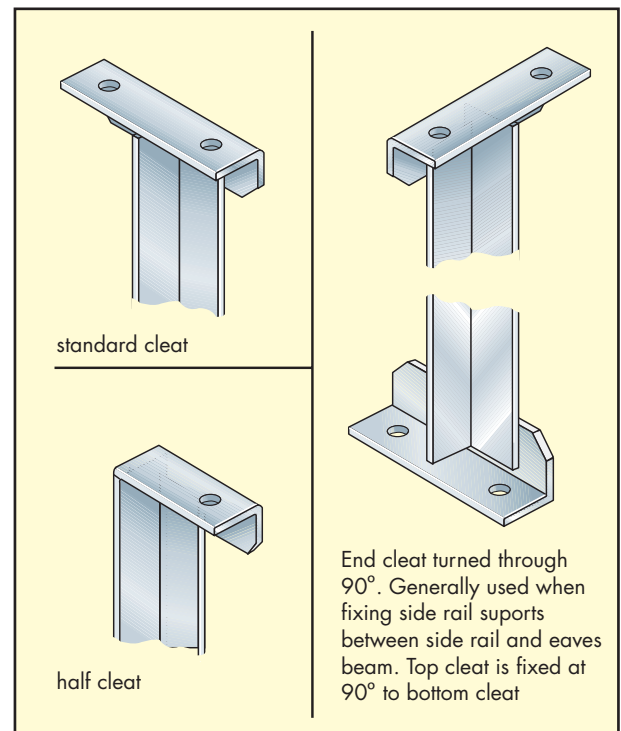

Note:

All holes in the side rail support strut are 14mm diameter except when the strut is attaching to a C section via a countersunk bolt (see page 31).

At this position only the hole should be 18mm diameter to suit the 16mm diameter countersunk bolt.

eaves struts

Eaves struts are fitted between the eaves beams and bottom purlin to give restraint to the eaves beam and additional support to the bottom purlin. Two types of eaves strut are available as per detail shown. Type required should be stated when ordering.

eaves struts typical fixing section through welded end connections

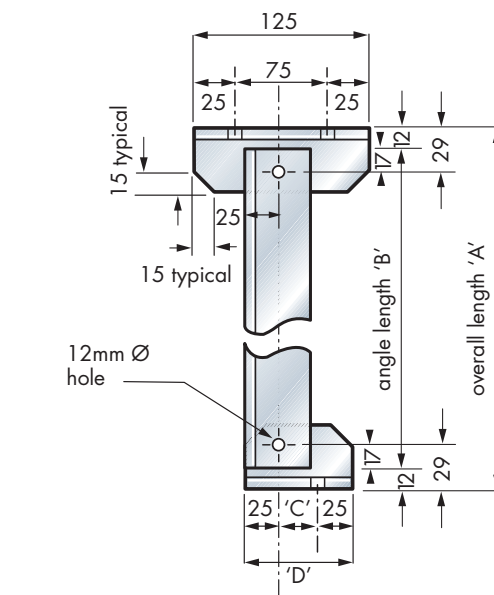
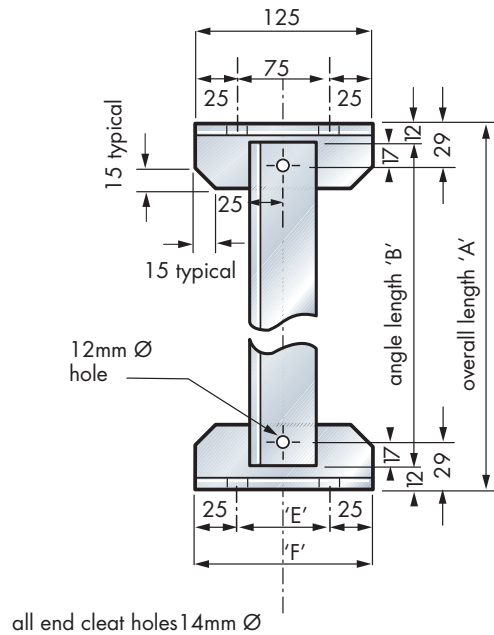
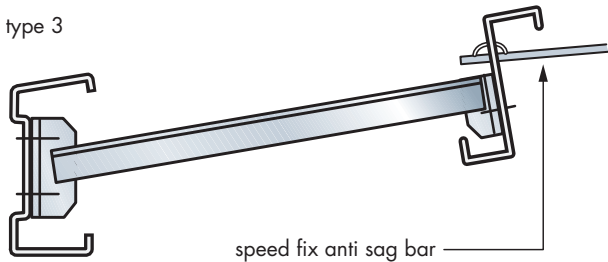
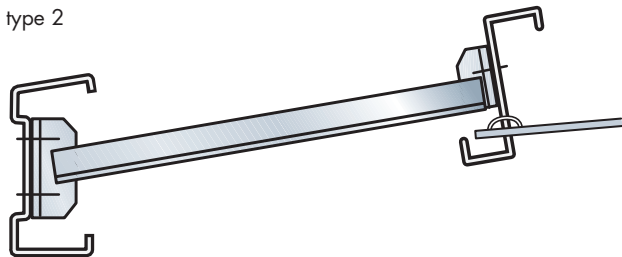
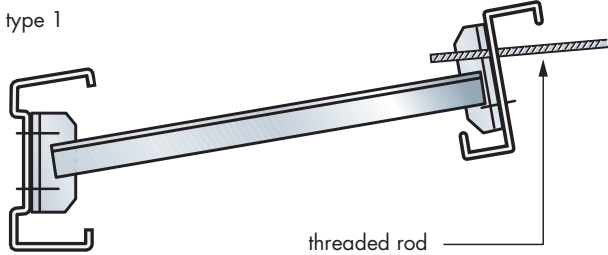

angle length = overall length minus 24

Note: For struts used with countersunk holes in C sections see page 31.

Section Ref	C	D	E	F
125	30	80	60	110
146	32	83	65	115
176	47	98	95	145
206/226	57	108	115	165
246	75	125	150	200
266	82	133	165	215
307	100	150	200	250
341	122	173	245	295
401	150	200	300	350

Note:

We recommend end cleats are welded at pre-determined angles as standard. Alternatively, end cleats supplied bolted as shown on request. Refer to detail sheet.

diagonal tie wires mid point support

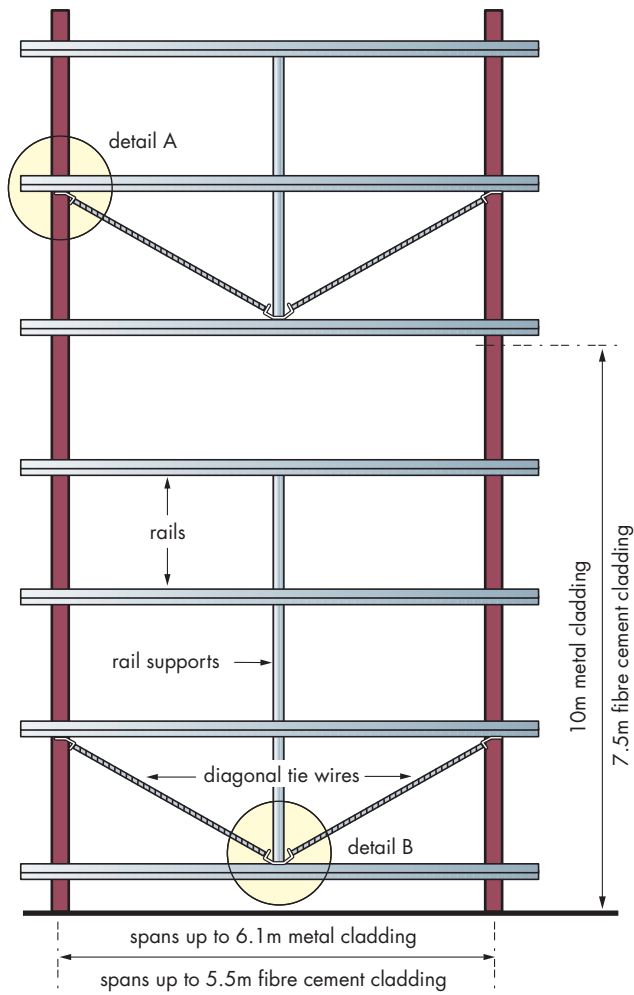

The drawings on the following pages show typical applications of a side rail support system for mid and third point supports which will suit most conditions

Diagonal tie wires should be used where there is not a suitable structural eaves member for supporting the side rail system, or where the height of the structural eaves member exceeds that shown on the diagram. Where diagonal tie wires are used, they can be fixed as shown between the bottom two lines of rails ensuring a straight line is achieved, and progressively working up the side of the building with rails and rail supports so the rail supports are in compression.

Alternatively diagonal ties can be fitted at eaves level between the top two lines of rails and work down the building so the rail supports are in tension.

Either way diagonal ties must be spaced so that the maximum distance between each run does not exceed 10m for metal cladding or 7.5m for fibre cement cladding.

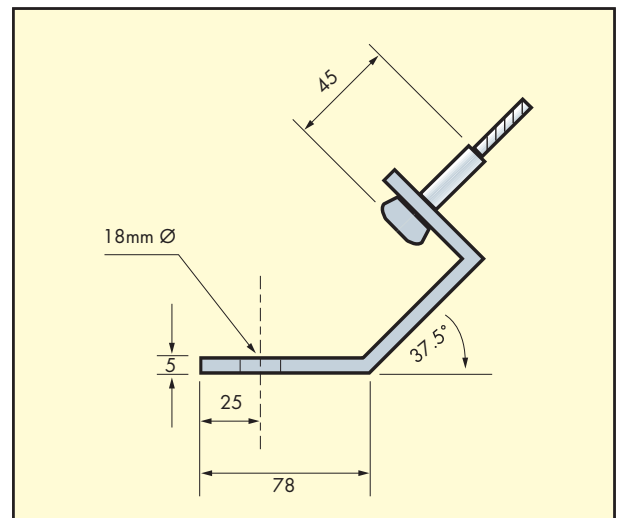

detail A

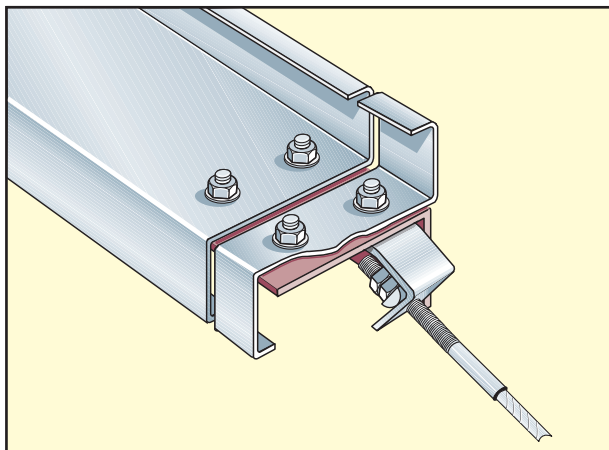

detail B

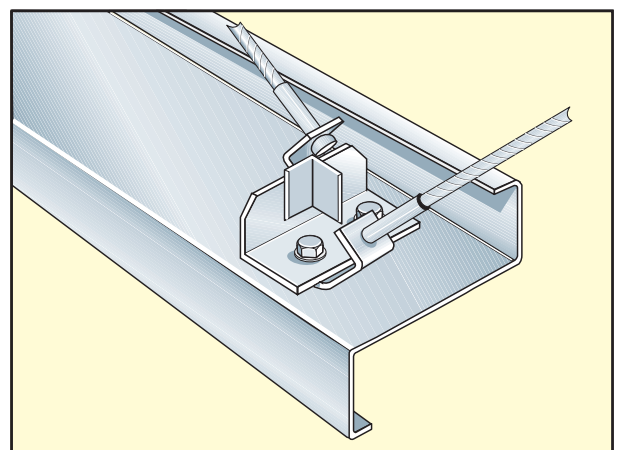

Albion side rail system

SECTIONS

diagonal tie wires third point support

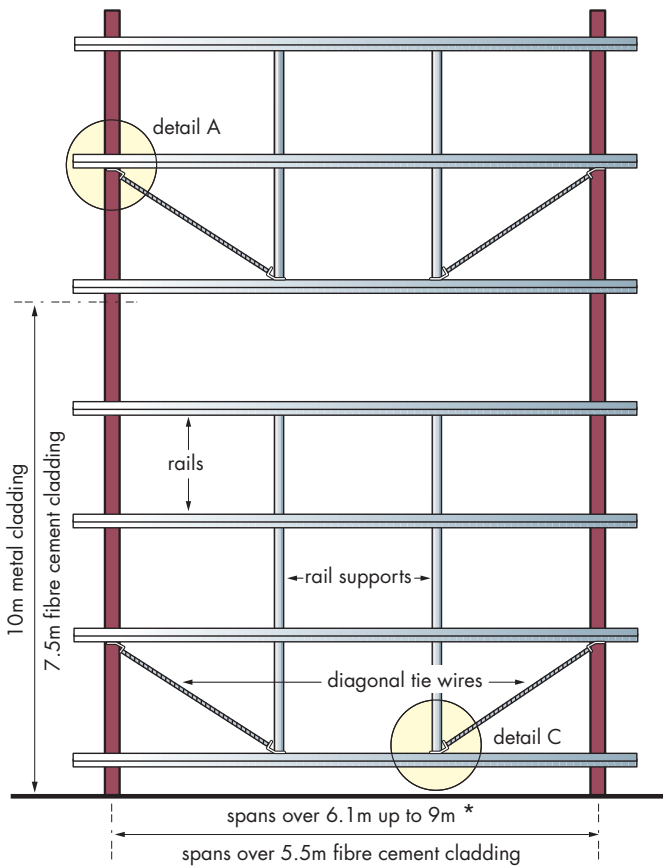

Diagonal tie wire complete assembly consists of 2 standard galvanised brackets, length 49 strand (7 x 7) galvanised steel wire rope with fixed and adjustable swaged connectors at either end. The wire rope has a guaranteed breaking strain of 1.72 tonnes with a swaged termination considerably stronger. There is a 75mm adjustment on length and an angular movement with a minimum of 20° up to a maximum of 60°. If an angle falls below 20° then additional side rail supports are required.

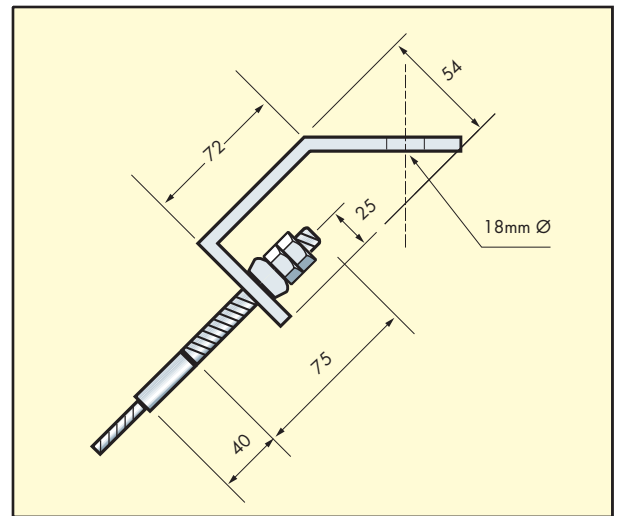

* Spans over 9m contact our Technical Department.

detail A

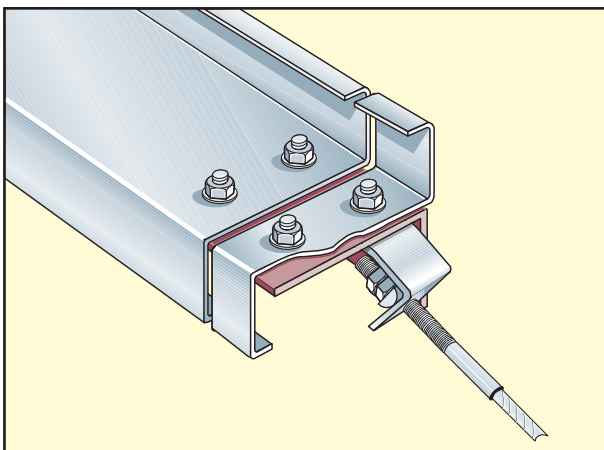

detail C

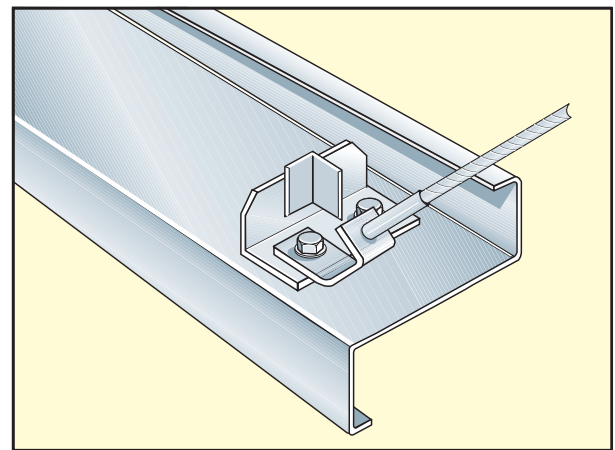

see page 22 for calculating side rail support length

cleader angles & rafter stays

Cleader angles are manufactured from pre-hot dipped galvanized mild steel and cold roll formed into an angle section 45 x 45 x 2.0mm thickness and 75 x 75 x 2.0mm thickness.

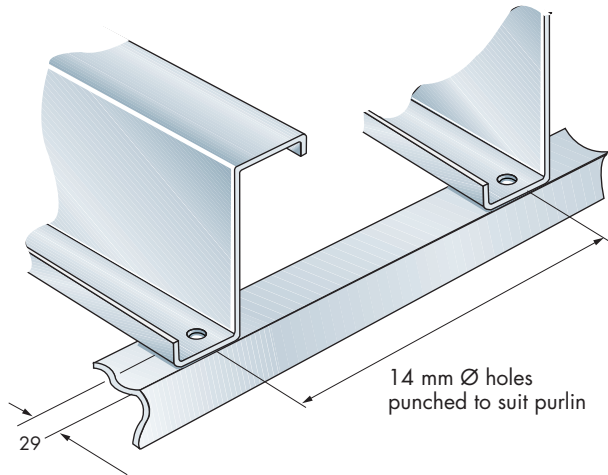

14mm Ø hole 29mm from end of purlin in bottom flange only.
Alternatively leave plain and use Tek screw attachments.

cleader joint detail

Detail shows typical Albion Sections connections. Other arrangements can be supplied to suit individual requirements.

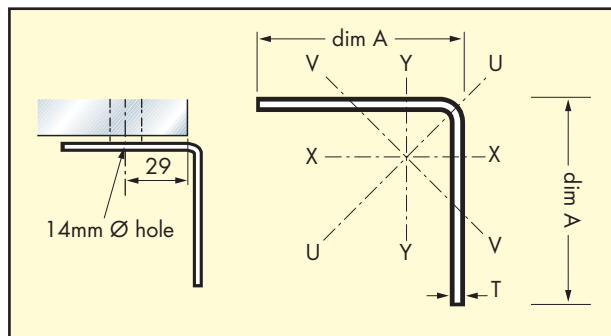
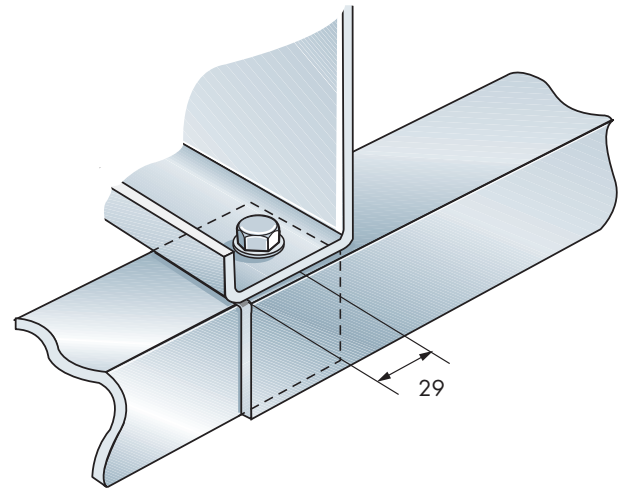

section properties

dim. A mm	t mm	wt Kg/m	lxx/lyy cm ⁴	lvv cm ⁴	luu cm ⁴	Zxx/Zyy cm ³
45	2	1.36	3.52	1.35	5.68	1.07
75	2	2.29	16.80	6.57	27.02	3.04

rafter stays/column stays

Rafter stays are manufactured from pre-hot dipped galvanized mild steel and cold roll formed into an angle section 45 x 45 x 2.0mm thickness.

Rafter stays are normally fixed to the outer sleeve hole, but additional holes in purlins can be added to suit requirements.

- * Standard dimension of 25mm alternatively can be punched to individual requirements.

Holes in rafter stays can be either 14mm or 18mm to suit purlin assembly bolts (but note that **both** holes in the stay are the same diameter).

- ▲ Dimensions to suit either standard sleeve punchings or individual requirements.

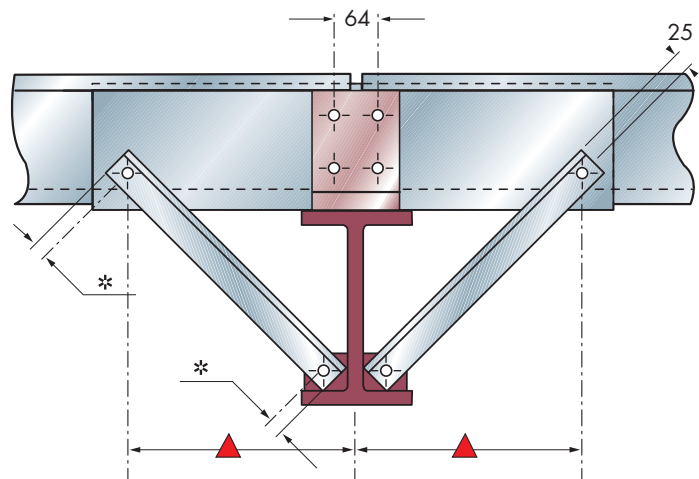

horizontal cladding systems

Horizontally fixed cladding provides the architect with increased versatility in the use of profiled sheeting. Albion Sections rails and fittings can provide an effective and versatile method of support. The following shows two systems which cater for individual forms of cladding used.

use of horizontal and vertical rails

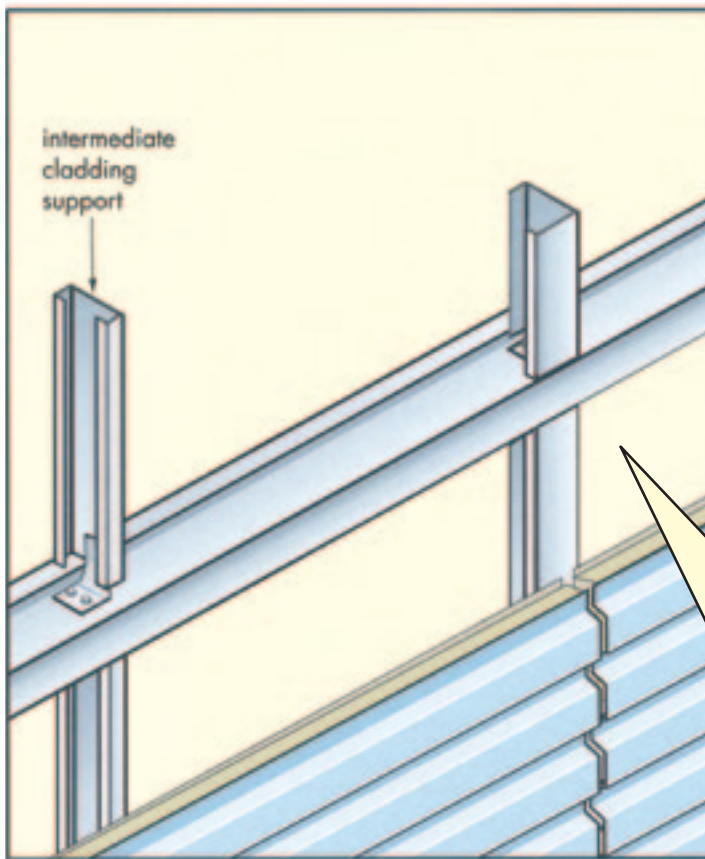

use of horizontal and vertical rails

The diagram shows a typical method of horizontal and vertical rail construction to accommodate the fixing of horizontal cladding.

The horizontal rails can be selected from the relevant load tables, i.e. sleeved, butted or double span. The safe working loads for the systems may be used provided that the vertical rails are spaced at no more than 2m centres. This method gives a vertical member to which the horizontal cladding is fixed and also acts as a side rail support.

Note:

If four or more rows of vertical rails are used per bay additional diagonal tie wires may be required.

Details shown are diagrammatic only, both vertical and horizontal rails can be either zed or channel sections.

Fixing cleats to vertical rails can be pre-fabricated to suit hole patterns and spot welded to vertical rails on request.

Cleats are fabricated from 3mm thick galvanized mild steel.

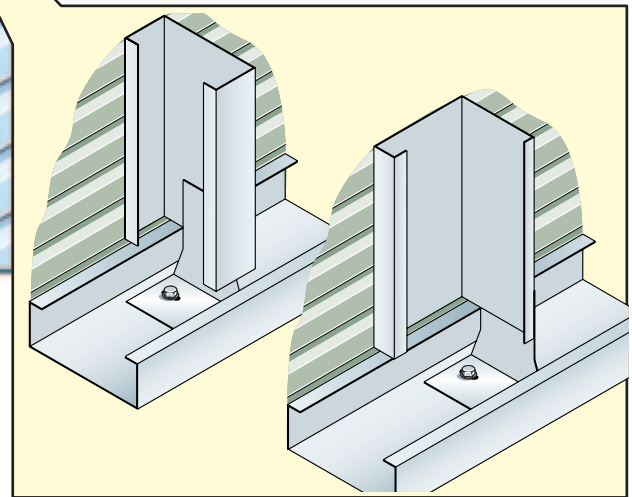

use of vertical rails

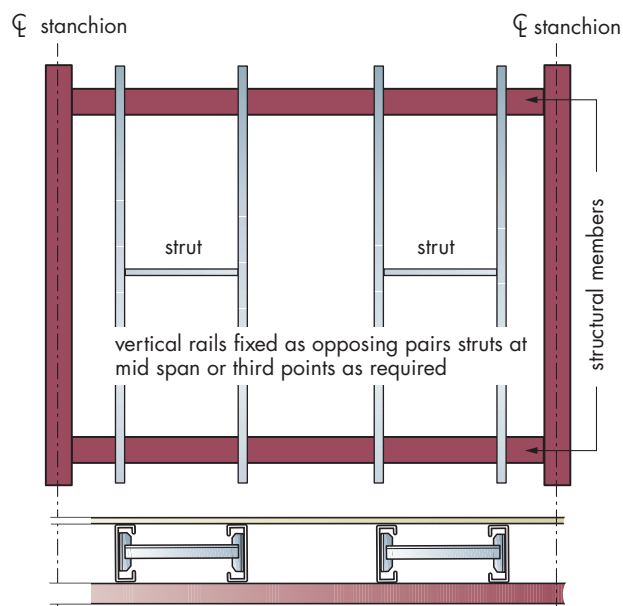

use of vertical rails

This method employs vertical rails spanning between a structural top and bottom member. The rails should be fixed as opposing pairs and side rail supports fixed between the pairs at mid or third points (dependant on span). The vertical rails should be selected from the single span load tables.

If height to eaves exceeds available rail capacity additional structural rail supports should be provided or horizontal and vertical rail system used.

Where height exceeds 6m consult our Technical Department.

horizontal cladding support systems

Due to the increasing use of horizontal cladding within the construction industry special attention has to be paid to the cold rolled support required. In particular where the cladding joint requires a minimum sheeting face of 140mm. For this requirement Albion Sections offer two solutions which can be fixed at column centres or within the span without affecting the structural layout of the building.

option 1: use of standard channels

Albion Sections standard range of channel sections used with special cleats as detailed below. Use Albion 145 deep channels (minimum) at cladding joints with standard 'C' sections as intermediate supports.

channel joint rail working load capacity UDL (kn)

channel ref	horizontal rail centres in metres				
	1.0	1.5	2.0	2.5	3.0
H14516	8.44	5.58	3.40	2.15	1.73
H14520	10.41	6.90	5.01	3.12	2.10
H17616	13.76	9.12	6.82	5.33	3.62
H17620	17.11	11.35	8.47	6.51	4.40

deflection restriction spot/150

Note: H' denotes channel sections with web as sheeting face

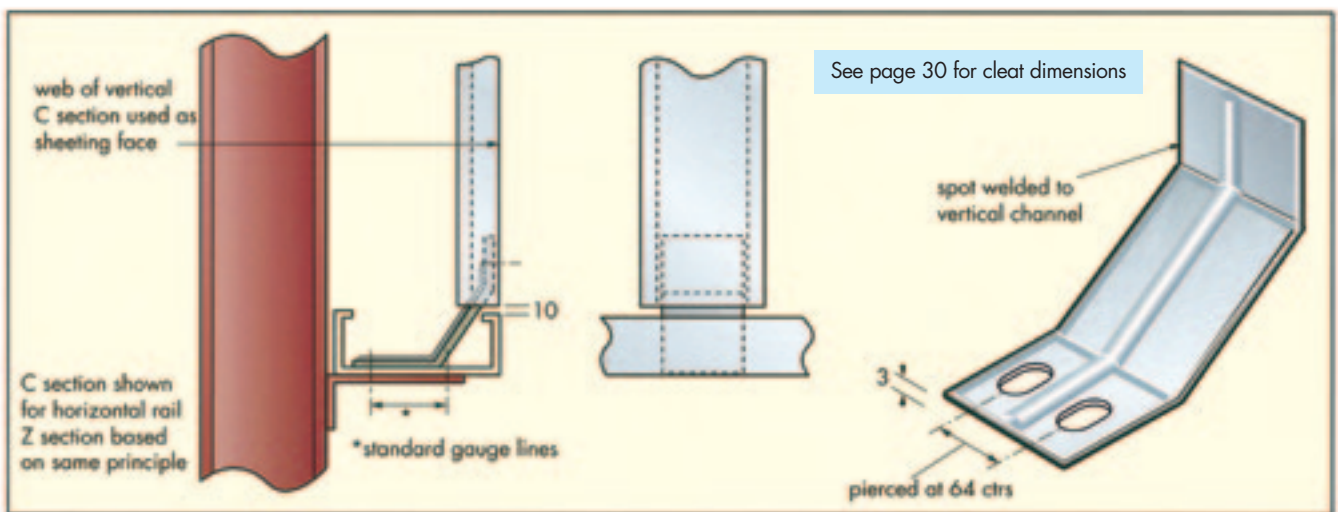
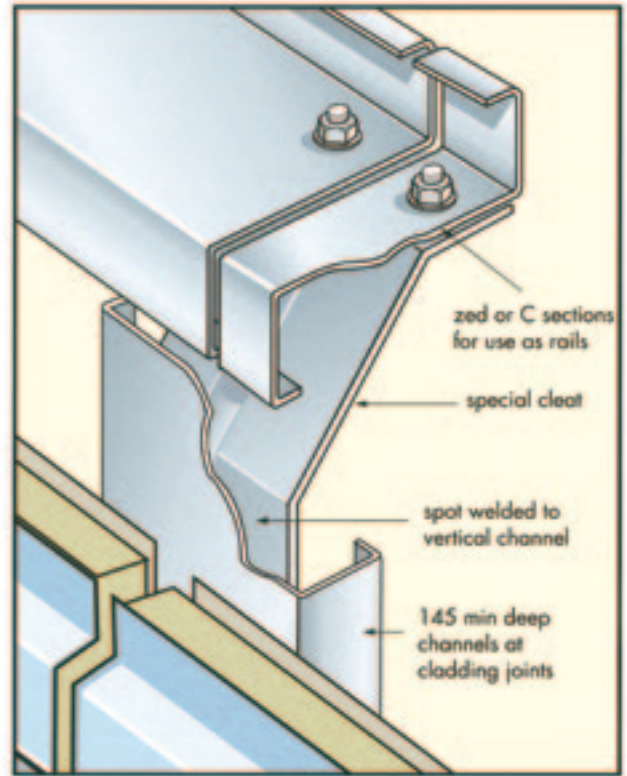

option 2: use of cladding joint rail

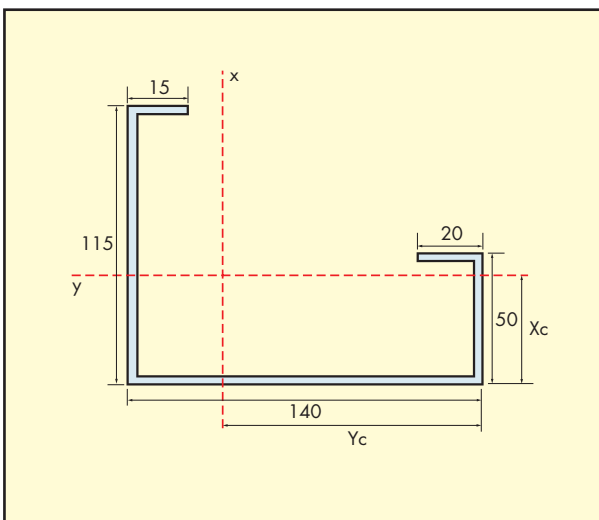
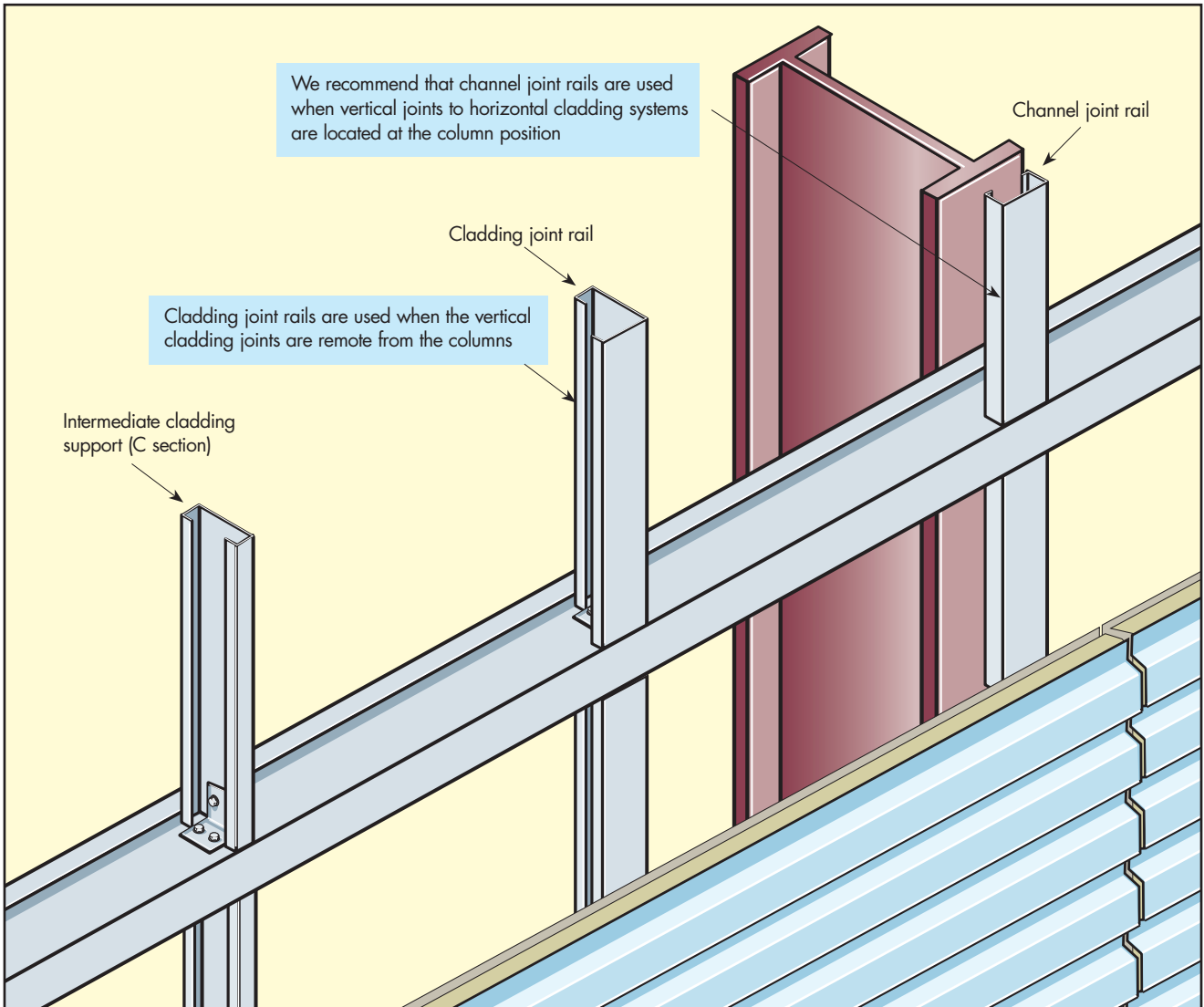

Note: Maximum length of section for cladding joint rail 3m.

section properties (cladding joint rail section)

reference	weight kg/m	l _{xx} cm ²	l _{yy} cm ²	X _c mm	Y _c mm	M _{cy} kN-m	M _{cx} kN-m
CJR 1.6	4.16	170.52	70.92	31.20	82.70	3.21	5.81
CJR 2.0	5.18	210.75	87.48	31.21	82.72	4.41	8.15

cladding joint rail working load
capacity UDL (kN)

reference	horizontal rail centres in meters				
	1.0	1.5	2.0	2.5	3.0
CJR 1.6	16.07	10.71	8.03	6.43	5.36
CJR 2.0	22.07	14.72	11.04	8.83	7.36

Note: 1. Deflection restriction span/150
2. a load factor of 1.6 has been applied

Albion vertical rail assemblies

SECTIONS

Vertical rail cleats are provided with slot holes to enable 'lining up' of side rail system

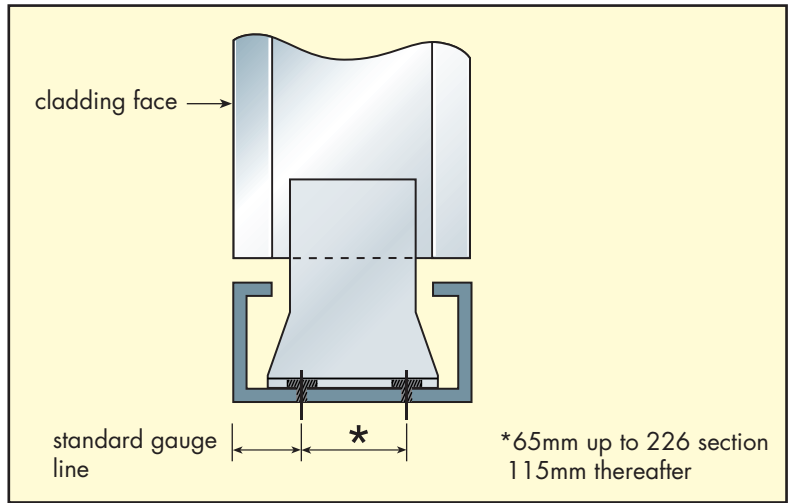
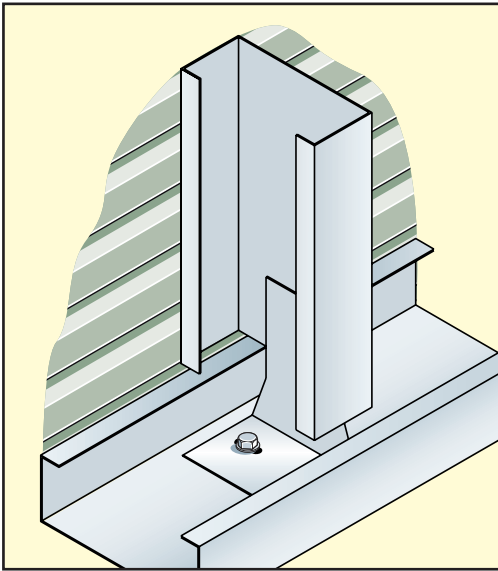

standard weld on cleats

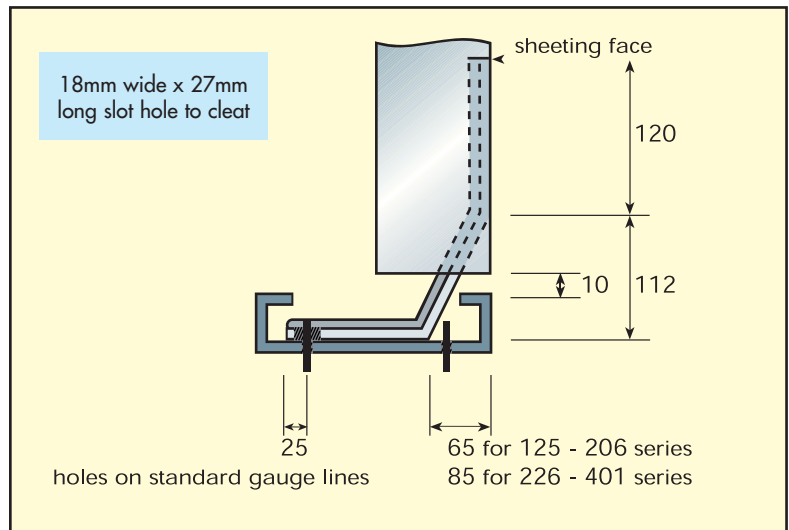
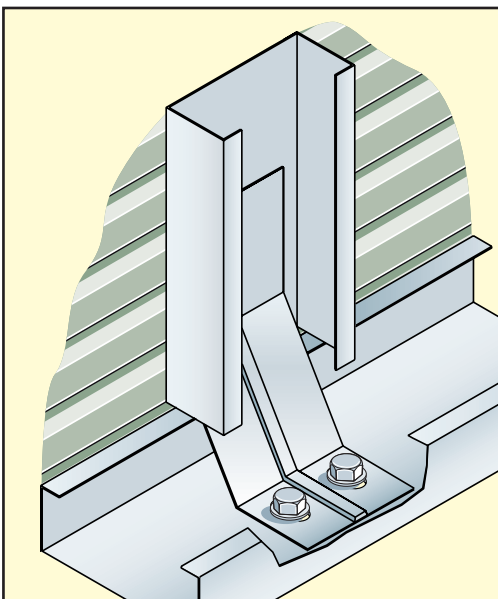
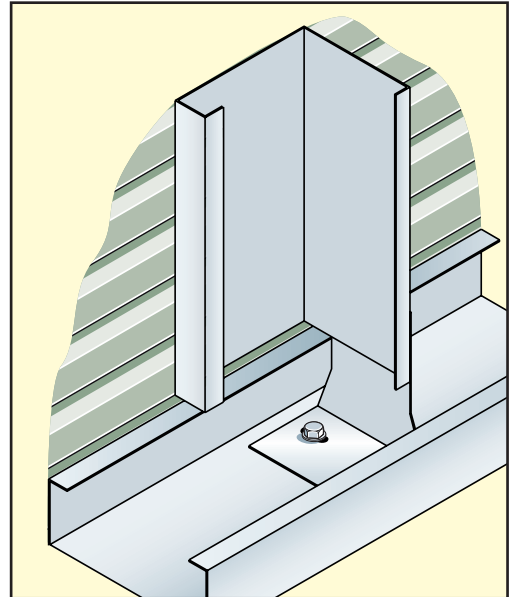
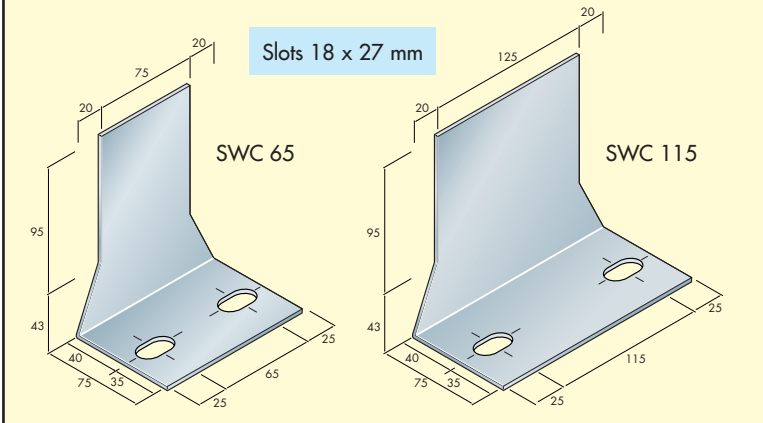

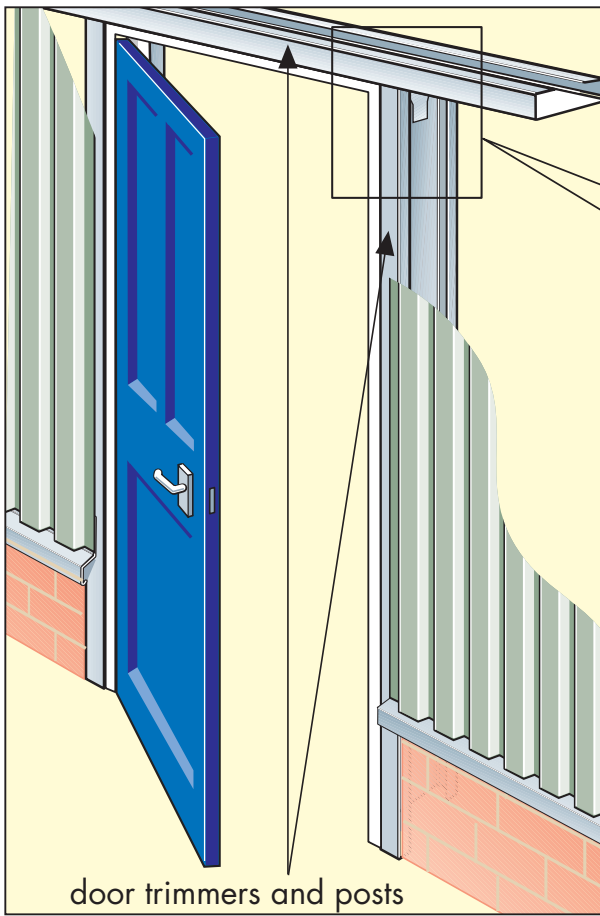

Albion channel sections are suitable for use as window trimmers and door framing. Details of typical applications and connections are as shown.

Trimmer cleats support manufactured from 3mm material. Pierced to suit relevant gauge lines. Bolted or spot welded to vertical channel.

Standard fixing cleat

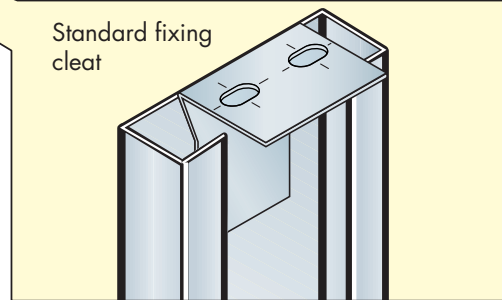

Examples of end cleat types available.

Other cleats can be fabricated to required specification.

Non-standard fixing cleats - where standard fixing cleats are not satisfactory.

type 1

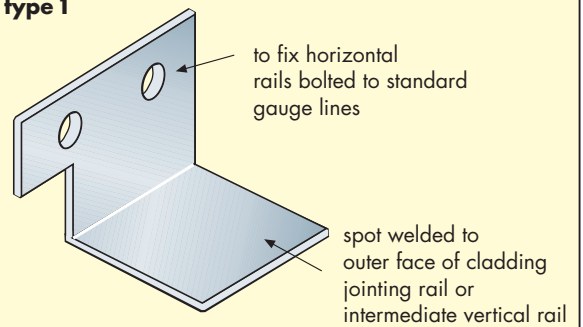

type 2

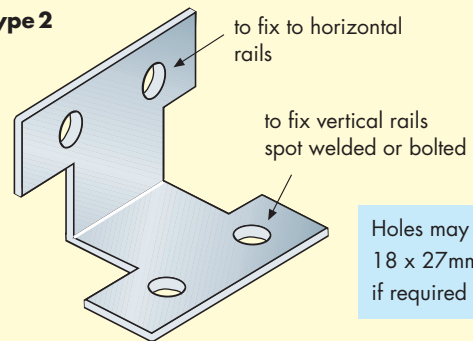

Holes may be 18 x 27mm slots if required

type 3

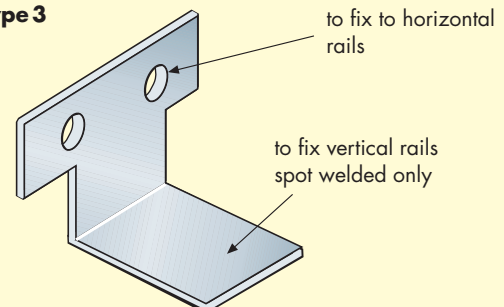

cleat dimensions to suit rail size

counterformed holes (Available 18mm diameter only)

All channel sections can be punched with counterformed holes on standard gauge lines, to accommodate flush fixing face when required.

Where side rail struts are used in this application ensure 18mm dia. holes are used in the strut end cleat.

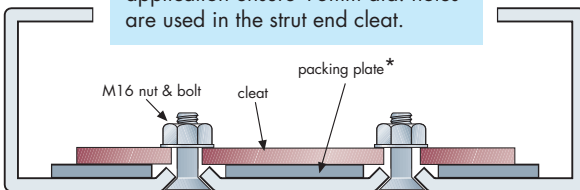

*packing plate

When using counterformed holes a packing plate is required to enable connections to be made to vertical supports.

Plate thickness 6mm.

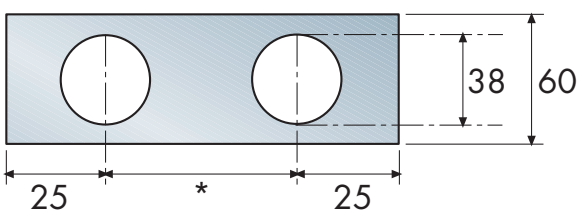

*to suit standard gauge lines

1 typical exposed eaves gutter detail

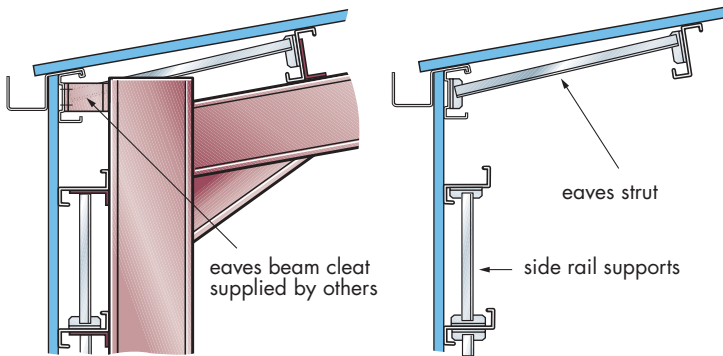

Eaves beams can be fixed as shown in typical corner detail outside the stanchion, or alternatively inside the stanchion when the cladding needs to be flush. In either case a minimum clearance is required of 6mm between eaves beams outside stanchions and 3mm each end when fitted inside. Load tables should be consulted for purlin and eaves beam capacity, and eaves strut requirements, ie mid span or third points.

Note: Where there is only one row of rails to the side of the building, special side rail supports can be used to hang from the eaves member. If the rails are being hung from a cold rolled eaves beam then the capacity needs to be checked for extra load. Eaves struts are required on spans 4m and above to resist twisting from combined loads of gutter weight and wind.

2 typical concealed eaves gutter detail

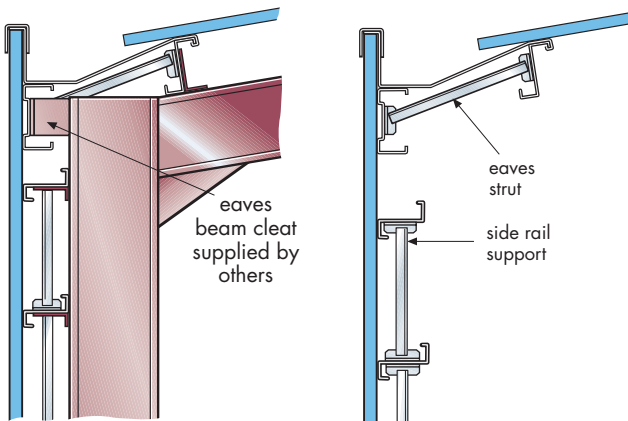

3 typical curved eaves with concealed gutter detail

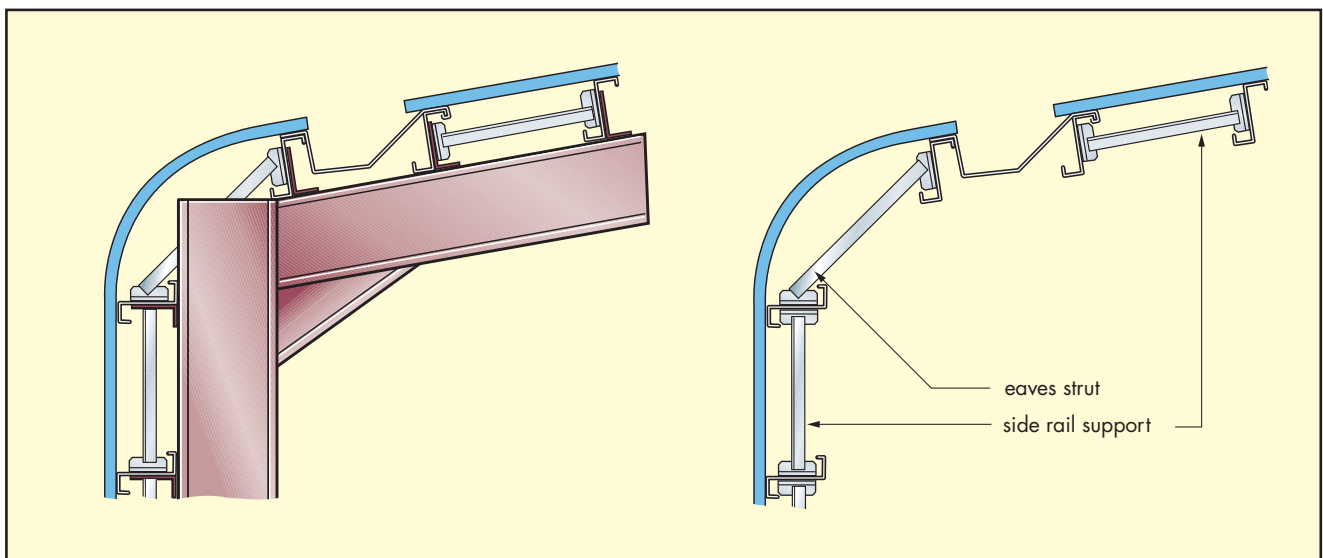

When gutter straps are fitted to the top flange of eaves purlin additional bracing is required to prevent excessive torsion. In most cases side rail supports acting as struts at mid or third points are sufficient, however, depending on design criteria such as size of gutter and distance from eaves purlin additional bracing may be required utilising diagonal tie wires. Please contact our design department for further information.

Highlighted below are various applications showing the growing use of C sections within the building industry.

vertical sheeting rails

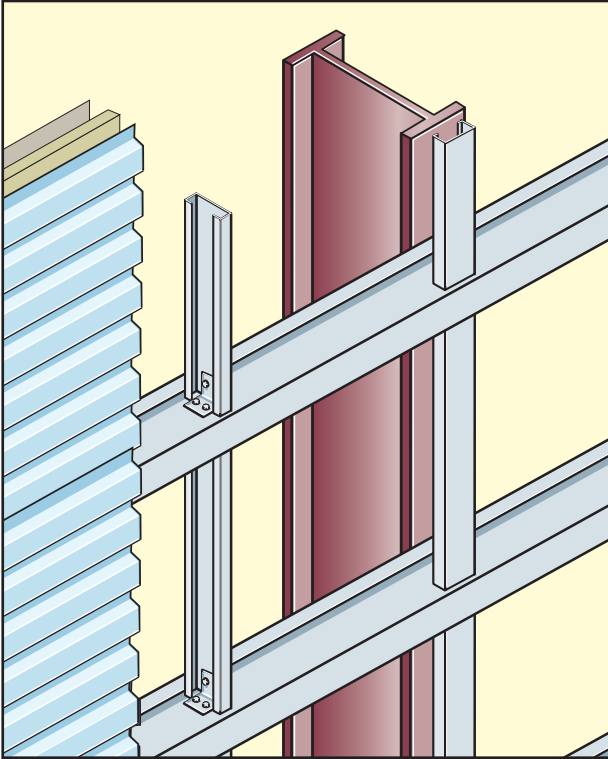

brickwork restraints

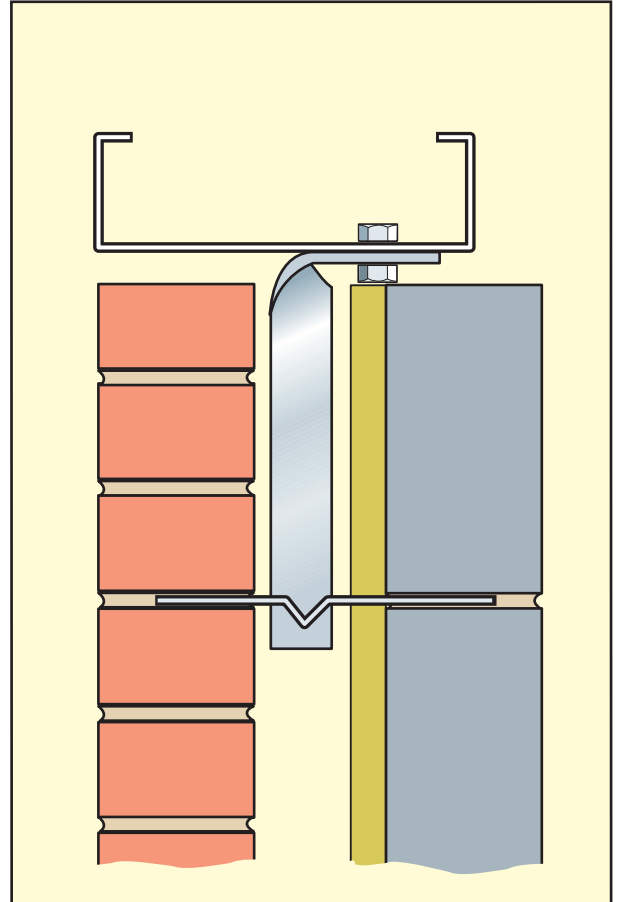

mezzanine floors

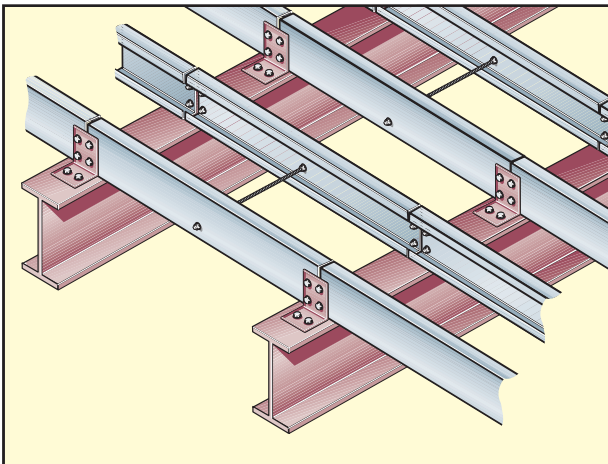
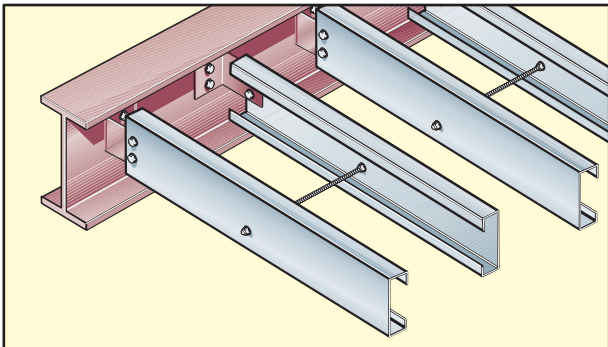

suspended ceiling system

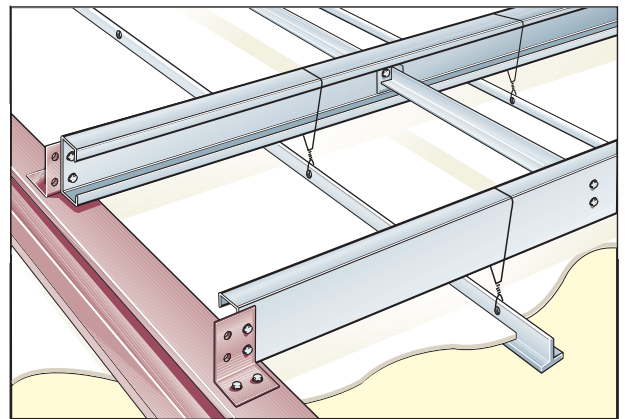

Albion top hat profile

SECTIONS

Albion Top Hat profile section is designed to span between horizontal cladding rails and provide intermediate support to horizontally spanning cladding panels.

Manufactured from pre-galvanised steel strip, grade S450, with a Z275 galvanised coating.

The Top Hat is provided in 1.5mm thickness, and in standard lengths of 4m.

section properties

Weight Kg/m	Area cm ²	I _{xx} cm ⁴	Z _{xx} cm ³
2.31	2.94	16.57	5.13

safe working loads (pressure or suction) (Kn)

Safe working loads are noted below for given span conditions and centres of horizontal rails.

A load factor of 1.4 is used (wind loads) and limiting deflection of L/150.

single spanning

1.0	1.5	1.8	2.0
12.0	5.0	2.9	2.15

double spanning

1.0	1.5	1.8	2.0
11.7	7.79	6.49	5.84

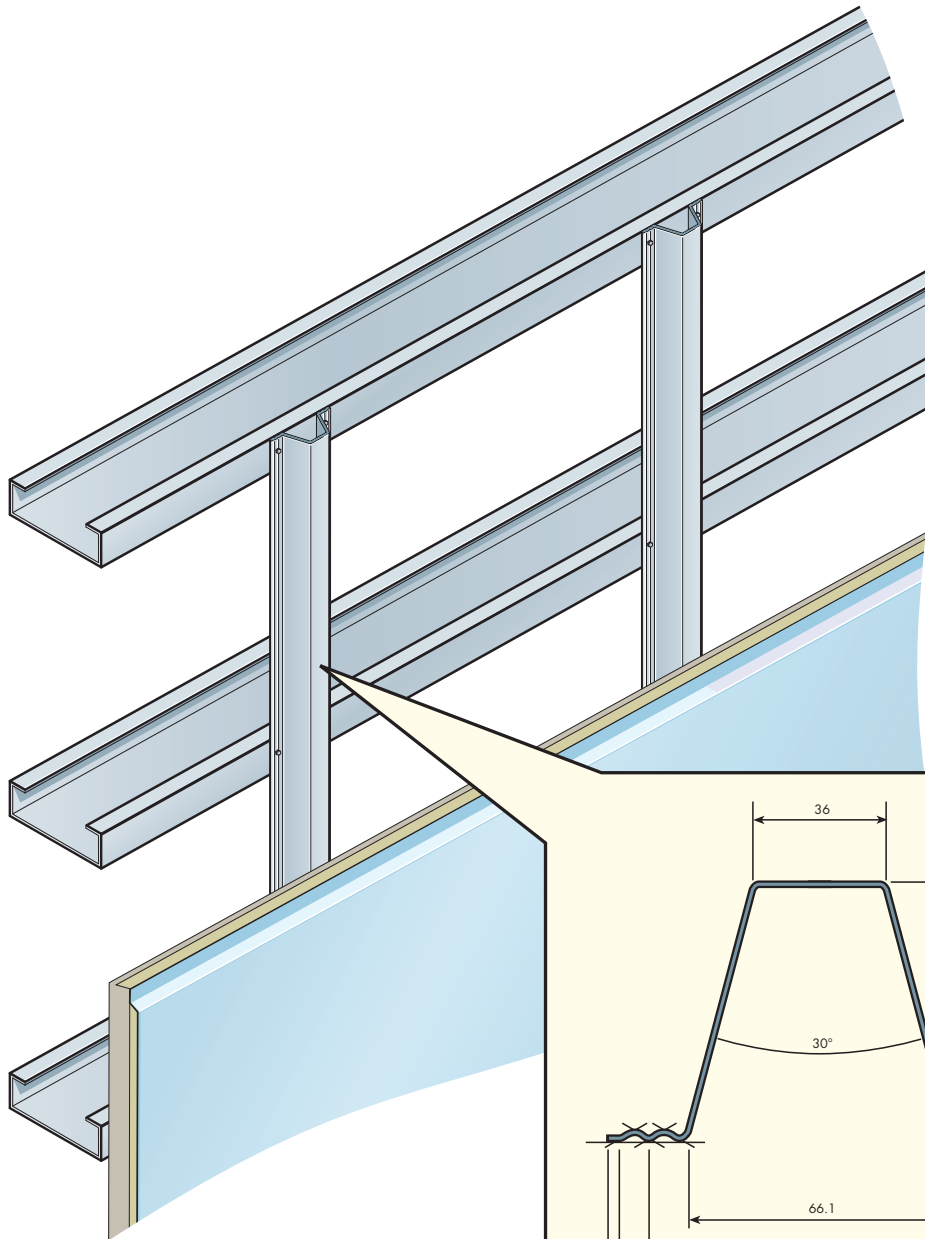

The working loads noted apply to the main section only. Fixings would need to be checked separately.

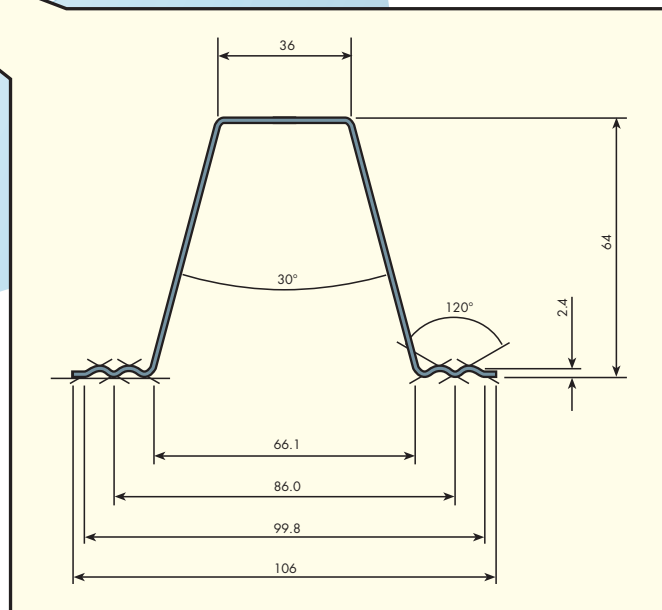

steel cladding

thickness mm	Kg/m ²	Kn/m ²
0.30	3.1	0.030
0.40	3.6	0.035
0.50	4.8	0.047
0.55	5.5	0.054
0.60	6.2	0.061
0.70	7.1	0.070

steel liner panels

thickness mm	Kg/m ²	Kn/m ²
0.40	4.00	0.040
0.45	4.60	0.046

fibre cement/asbestos (single skin)

	Kg/m ²	Kn/m ²
standard three	14.70	0.145
standard six	16.00	0.157
profile 6 m	17.00	0.167

fibre cement/asbestos (double skin)

	Kg/m ²	Kn/m ²
profile 6 *	30.00	0.295
profile 6 *	32.00	0.314
panel sheet *	27.80	0.273

*including insulation & battens

slate roof tiles

weights shown are 'as laid'	Kg/m ²	Kn/m ²
400 x 200	20.64	0.202
500 x 250	20.38	0.199
600 x 300	19.98	0.196
concrete tiles	67.00	0.670

composite cladding

sheet mm	foam mm	Kg/m ²	Kn/m ²
0.55	28	9.67	0.095
0.55	46	10.30	0.101
0.70	28	11.02	0.109
0.70	46	11.65	0.115

aluminium

thickness mm	Kg/m ²	Kn/m ²
0.55	1.86	0.019
0.70	2.37	0.024
0.90	3.05	0.030
1.20	4.07	0.040

non-restraining cladding

	thickness mm	Kg/m ²	Kn/m ²
steel	0.6	7.0	0.069
steel	0.7	8.1	0.080
steel	0.8	9.2	0.091
aluminium	0.9	3.5	0.035

over purlin linings

	thickness mm	Kg/m ²	Kn/m ²
glass wool	60	0.70	0.007
glass wool	80	0.90	0.009
aeroliner	30	1.55	0.016
aeroliner	50	2.20	0.022
plaster board	10	8.26	0.087
plaster board	12	11.22	0.110
fibre board	12	4.38	0.043
fibre insulating board	10	7.85	0.077

Section Properties and Load Tables

For Engineer or Specifier, this brochure provides section properties for Albion's range of zed, cee and eaves beam profiles based on S450 material. Also load span tables for purlin, rail and eaves beam systems. To be read in conjunction with the Technical Manual.

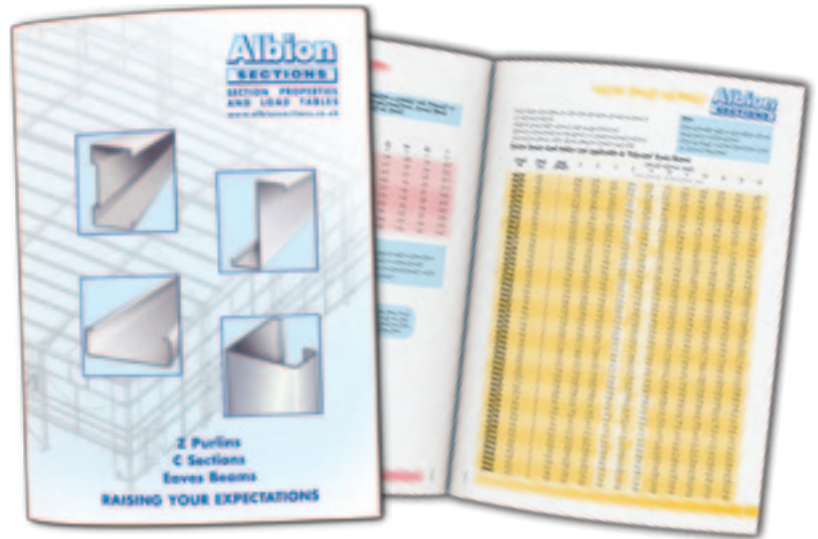

Sigma Purlins

The Sigma purlin has been developed to provide an efficient purlin system both in strength/weight ratio and requirement for accessories (sleeves, sag rods etc). This brochure provides detailed information on section dimensions and properties, typical system details and load/span tables. Design in accordance with BS EN: 1993-1-3:2006.

Structural Framing Systems: External Walling

This brochure provides information for the Engineer or Specifier on Albion's stud and track range. Section properties, typical system details and load/span tables are included. Typical applications of the system are external cladding support and internal partitions.

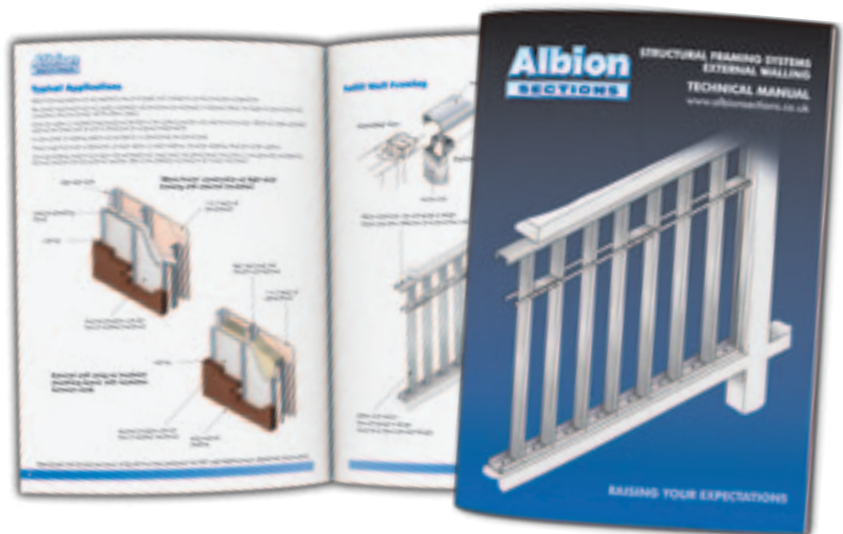

Brochures are available for download at www.albionsections.co.uk
or contact us for a hard copy

Why Choose Albion Sections:

- High strength steel grade S450, as standard
- Extensive range of Zed, Cee and Eaves Beam sections
- Lead time 5-7 working days
- Fully dynamic punching facility
- In house Technical support backed up by PI Insurance
- Free Albion Engineer design software
- Free Albion detailing software

Albion
SECTIONS

ALBION SECTIONS LIMITED

COLD ROLLED SECTIONS FOR THE CONSTRUCTION AND ENGINEERING INDUSTRIES

MAINLAND U.K.

ALBION ROAD,
WEST BROMWICH,
WEST MIDLANDS.
B70 8BD

NORTHERN IRELAND

UNIT 1, RATHDOWN ROAD,
LISSUE INDUSTRIAL ESTATE,
LISBURN, COUNTY ANTRIM.
BT28 2RE

Tel: +44 (0) 121 553 1877

Fax Sales/General: +44 (0) 121 553 5507

Email: sales@albionsections.co.uk www.albionsections.co.uk