



# Duplexvent DV65/DV82/DV130 Entro-V

Part No: 90001243/90001244/90001245

RESIDENTIAL HEAT RECOVERY UNITS

User, maintenance and installation manual



# Table of content

<b>1. TABLE OF CONTENT</b> .....	2
<b>2. WARNINGS &amp; SAFETY INFORMATION</b> .....	3
<b>3. MAIN COMPONENTS</b> .....	4
<b>4. TECHNICAL DATA</b> .....	5
<b>6. UNIT DIMENSIONS</b> .....	6
<b>7. UNIT LABELS</b> .....	7
<b>8. INSTALLATION</b> .....	8
8.1. Wall and Floor Mounting.....	8
8.2. Discharge Condensate Installation.....	9
<b>9. OPTIONAL SPIGOT INSTALLATION</b> .....	10
<b>10. CONTROL OPTIONS</b> .....	11
10.1. Filter Function.....	11
10.2. By-pass Function (Optional).....	12
10.3. Frost Protection Function.....	12
10.4. Boost Function.....	12
10.4. Warnings.....	13
10.5. Child Proof Protection Function.....	13
10.6. Sensor (VDD) (Optional).....	13
10.7. Basic controller Functions .....	14
<b>11. MAINTENANCE INSTRUCTIONS</b> .....	15
11.1 Heat Exchanger Maintenance .....	15
11.2 Filter Maintenance .....	16
11.3 Fan Maintenance .....	16
<b>12. OPERATING INSTRUCTIONS</b> .....	17
<b>13. CONTROL FEATURES</b> .....	18
<b>14. TROUBLESHOOTING</b> .....	19

# 1. WARNINGS & SAFETY INFORMATION



***Please read this important safety information before proceeding to the manual.***

- 🌀 Install this product in an environment where the temperature ranges from 0 °C to +40 °C and the relative humidity is less than 80%. If condensation is expected to form, heat up the fresh outside air by a duct heater etc.
- 🌀 This unit is designed for the indoor installation only, it is not suitable for outdoor installation.
- 🌀 It is recommended that no packaging should be removed until the unit reaches the installation point so that no damage occurs on the unit. Select an adequately sturdy position for installing the product and install it properly and securely.
- 🌀 This unit must only be used and installed according to the installation, user and maintenance manual.  
(Otherwise all guarantees and warranties will be void.)
- 🌀 Electric supply to unit should be isolated before performing any maintenance or repair work.
- 🌀 Any work on the unit apart from basic maintenance should be carried out by a suitably qualified person.
- 🌀 It is recommended protective gloves to be worn during installation.
- 🌀 Only original manufacturer replacement on spare parts should be used.
- 🌀 Unit should not be operated without all external panels in place.
- 🌀 Do not touch the hot surfaces during the operation of the unit.
- 🌀 This product must not be disassembled under any circumstances. Only authorized repair technicians are qualified to conduct disassembly and repairs.
- 🌀 Perform the preliminary inspections before starting-up the unit.
- 🌀 By not following these instructions when carrying out routine maintenance of the unit may result in damage to the unit and/or injury of the operator.
- 🌀 Dirty filters should be placed in a sealed container and be destroyed in compliance with local solid waste procedures.
- 🌀 Care should be taken to not damage the fans when cleaning. It is recommended that a soft brush or vacuum cleaner to be used.

## 2. THE UNIT'S PACKAGE INCLUDES

- ✓ Unit
- ✓ Bracket x 1
- ✓ Drainage x 1
- ✓ M8 Chock x 4
- ✓ M8 Lock Nut x 4
- ✓ 10 mm Frame Fixing Anchor x 3
- ✓ M6\*70 Chipboard Screw x 3
- ✓ User Guide x 1
- ✓ Control Panel and Guide x 1
- ✓ Panel Trunnion (Spare) x 3
- ✓ M6\*15 Imbus Bolt (Spare) x 2

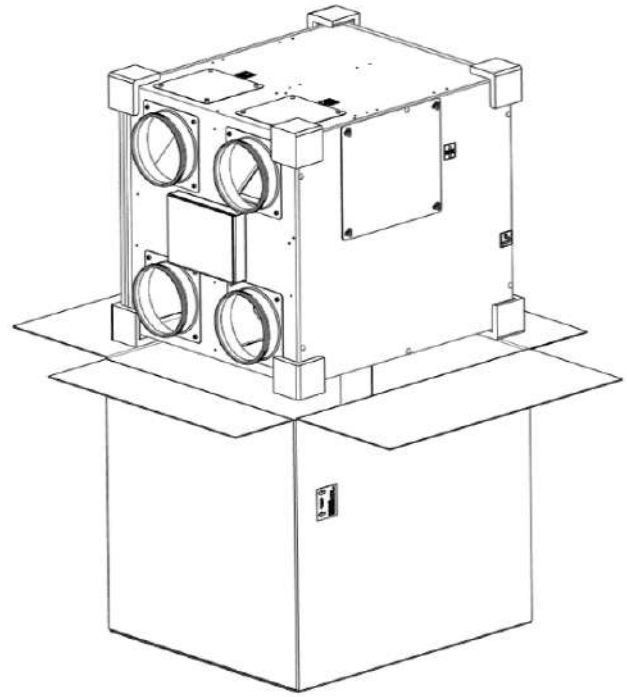

## 3. MAIN COMPONENTS

The unit is designed to recovering thermal energy from the exhausted air in a ventilation system. The recovered energy is directly transferred to the incoming fresh air supply, this can reduce load on the property heating systems.

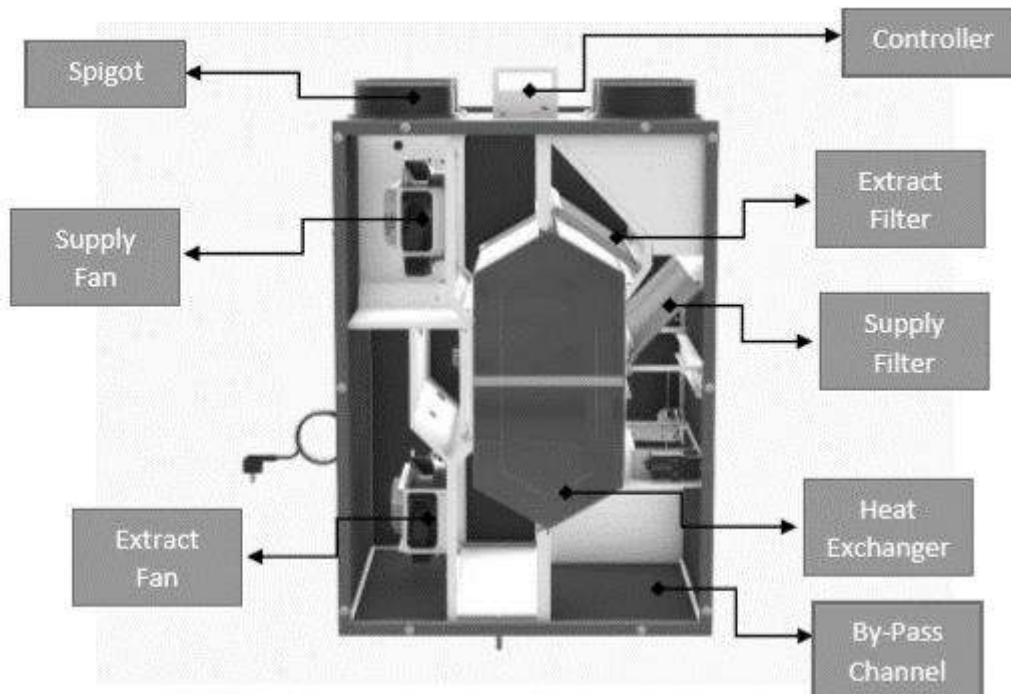

## 4. TECHNICAL DATA

Specification	DV65 Entro-V	DV82 Entro-V	DV130 Entro-V
Air flow m <sup>3</sup> /h / l/s @100Pa	242 / 67.2	300 / 83.3	460 / 127.7
For dwelling floor area up to (m <sup>2</sup> )	116	184	277
Reference dwelling	3 bed house	4 / 5 bed house	5 / 6 bed house
Thermal efficiency	84 - 88%	83 - 86%	84 - 87%
Heat exchanger	Counterflow (Plastic)	Counterflow (Plastic)	Counterflow (Plastic)
SEC class	A+	A	A
Electrical supply	230V / 1ph / 50Hz	230V / 1ph / 50Hz	230V / 1ph / 50Hz
Max power consumption	100 W	166 W	230 W
Sound level @ 3m (dB(A))	32 - 43	35 - 48	36 - 48
Specific Power Input (SPI) (W/ (m <sup>3</sup> /h))	0.295	0.27	0.267
Fans	EC	EC	EC
Electric heater	2 x 50 W	2 x 83 W	2 x115 W
IP classification	IP54	IP54	IP54
Weight (kg)	45	50	65
Dimensions (LxDxH) (mm)	580 x 430 x 690	580 x 530 x 795	716 x 690 x 795
Controls	4 - speed manual controller Optional digital controller	4 - speed manual controller Optional digital controller	4 - speed manual controller Optional digital controller
Duct diameter (mm)	160	160	200
Condensate discharge	1/2 inch BSP thread	1/2 inch BSP thread	1/2 inch BSP thread
Summer Bypass damper	100% Automatic	100% Automatic	100% Automatic
Frost protection	Yes	Yes	Yes
Filter class	(G4) ISO Coarse 55%, optional (F7) ISO ePM1 55%	(G4) ISO Coarse 55%, optional (F7) ISO ePM1 55%	(G4) ISO Coarse 55%, optional (F7) ISO ePM1 55%
Optional BMS Connectivity	Communication through I2C-Modbus	Communication through I2C-Modbus	Communication through I2C-Modbus
Casing	Galvanised steel. Powder paint. (20mm insulation)	Galvanised steel. Powder paint. (20mm insulation)	Galvanised steel. Powder paint. (20mm insulation)
Mounting	Wall, Floor	Wall, Floor	Wall, Floor
Orientation of unit	Right or Left-handed	Right or Left-handed	Right or Left-handed
Part no.	<b>90001243</b>	<b>90001244</b>	<b>90001245</b>

## 6. UNIT DIMENSIONS

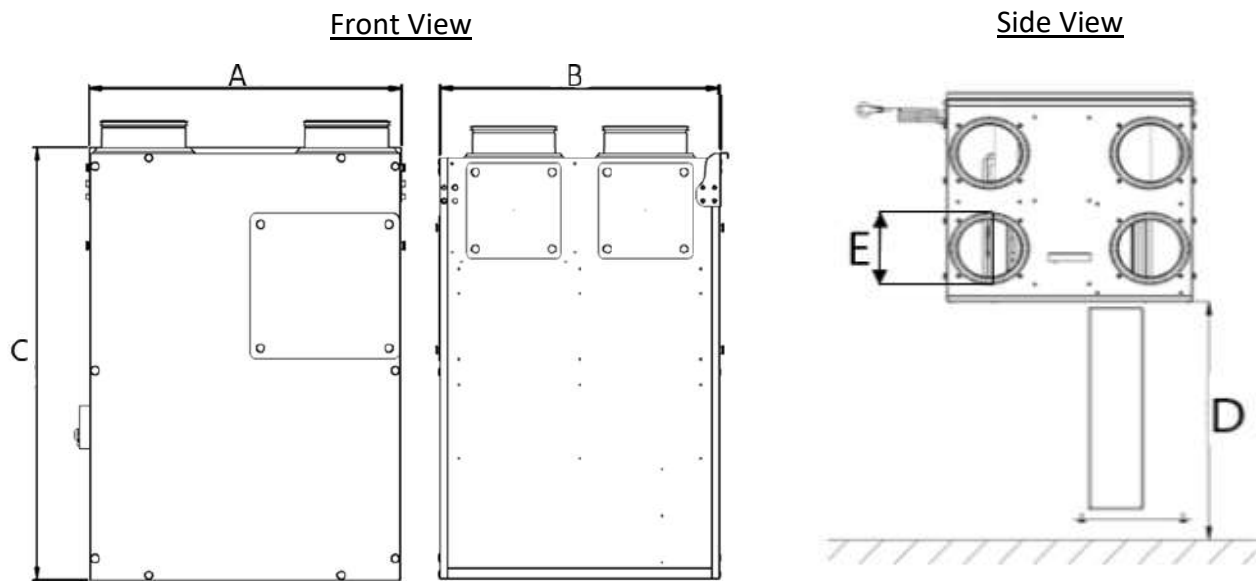

MODELS	A	B	C	D	E
DV65 Entro-V	580	430	690	400	160
DV82 Entro-V	580	530	795	600	160
DV130 Entro-V	716	690	795	800	200

### Service Space:

- ☛ All measurement values are mm.
- ☛ A clear space must be provided in front of the unit for service.
- ☛ E is the spigot diameter.
- ☛ D is the minimum service space required.

## 7. UNIT LABELS

Please see product labels and their individual definitions:

ORDER NO			
DEVICE NAME	<b>DV65 Entro-V</b>		
DEVICE MODEL	K29.35.1.1.1.0.00		
AIR FLOW	275	m <sup>3</sup> /h	
EXTERNAL STATIC PRESSURE	150	Pa	
SUPPLY/EXHAUST FILTER	G4 PANEL		
FAN TYPE, NOMINAL MOTOR POWER, CURRENT, VOLTAGE	TYPE	W	A
	EC PLUG	83	0,75
HEAT RECOVERY TYPE	Counter Flow		
PRODUCTION DATE	MAY 2019		
SERIAL NUMBER	19.29.0005		

Product Label

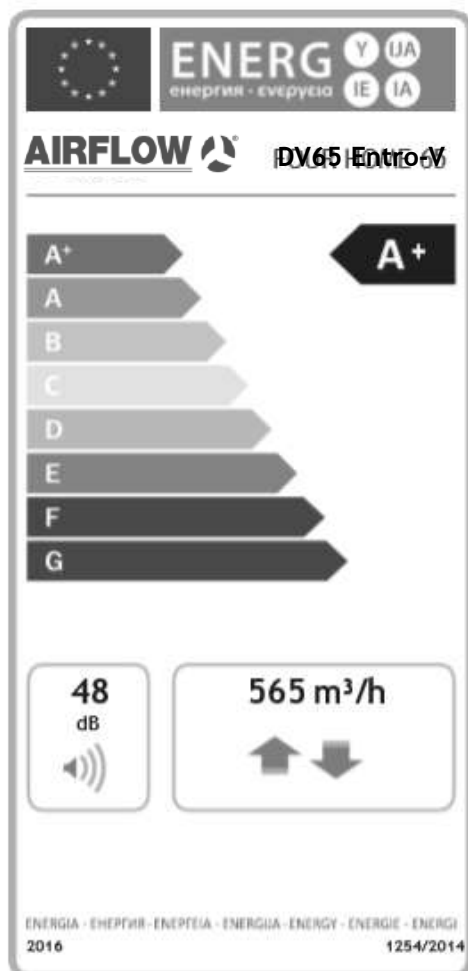

Energy Label



Return Air



Supply Air

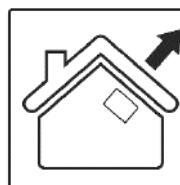

Exhaust Air



Outside Air



Drainage

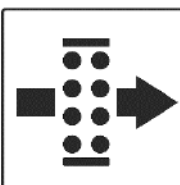

Filter



Electric Panel

# 8. INSTALLATION

## 8.1. Wall and Floor Mounting

When wall mounting, consider the wall's strength and its suitability.

When floor mounting, please ensure that there is enough space below the unit to accommodate the condensate drain.

Take into consideration the position of the unit and ensure there is adequate access for installation, operation and maintenance (see page 6).

Care should be taken when choosing the location of the unit. Although the unit has been designed to minimise noise output, some mechanical noise is unavoidable and may be transmitted through the unit. It is not recommended the unit to be mounted against noise sensitive rooms.

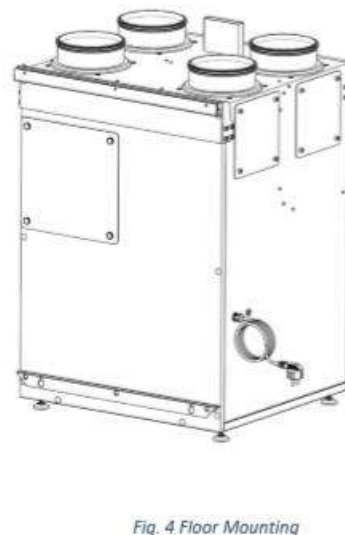
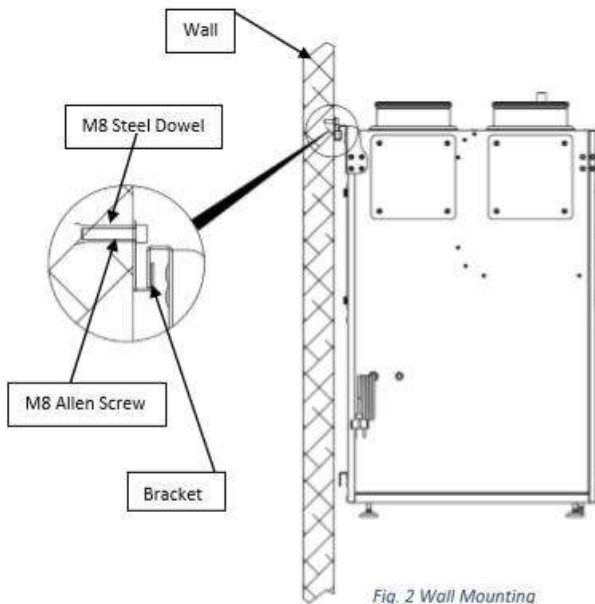
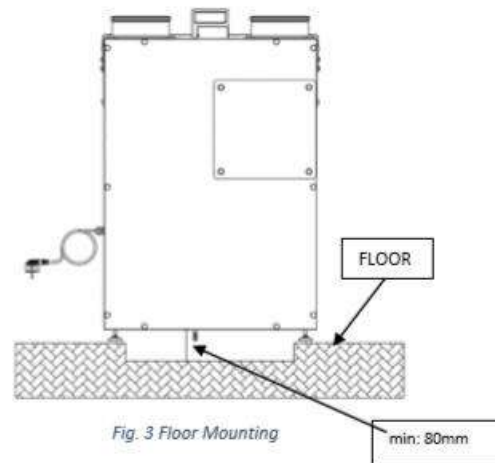
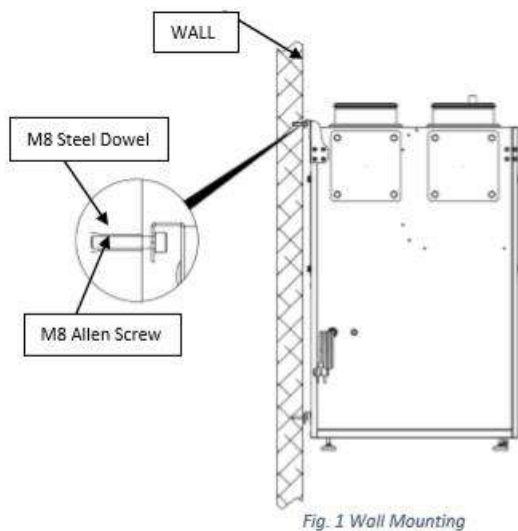

- ⦿ M8 flush steel dowel is fixed to wall.
- ⦿ The M8 imbus bolt is compressed so that it passes through the hanger.
- ⦿ Hang the device onto the bracket.
- ⦿ Must be horizontal balanced when wall and floor mounting.

## 8.2. Discharge Condensate Installation

Moisture condensed water should be drained out of the unit, to prevent water damage inside heat recovery unit and ductwork system.

The following precautions should be observed:

- I. Condensate pipe connections to main drainage line should not be less than the diameter of the drainage outlet connection (Not less than a diameter of 1/2 inch BSP).
- II. A pipe coupling should be fitted at the pipe connections enabling easy disconnection for service and maintenance.
- III. Suitable water trap measures should be taken (see below). Pipe runs should slope away from the unit enabling condensation to drain away.

\*Apply a fixing adhesive to the drain connection part for sealing.

\*Install the condensation connection part in the allocated drainage space.

\*Tighten it well by using a spanner.

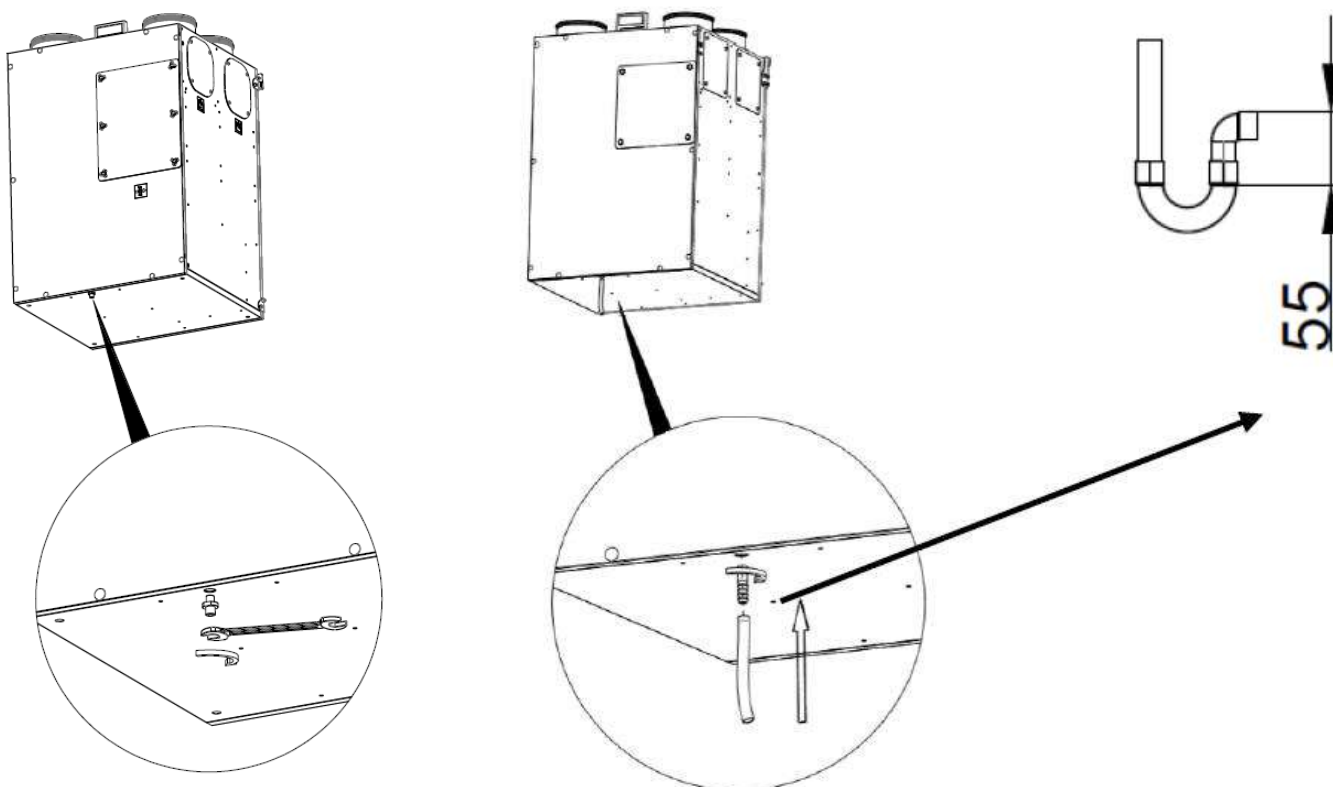

## 9. OPTIONAL SPIGOT INSTALLATION

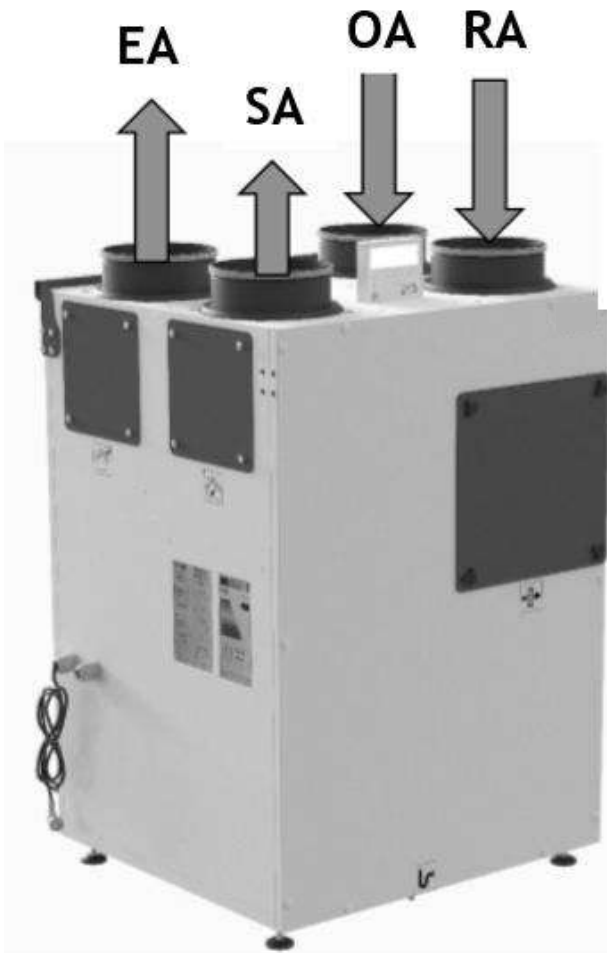

- EA: Exhaust Air  
RA: Return Air (from room)  
OA: Outdoor Air  
SA: Supply Air (to room)

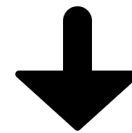
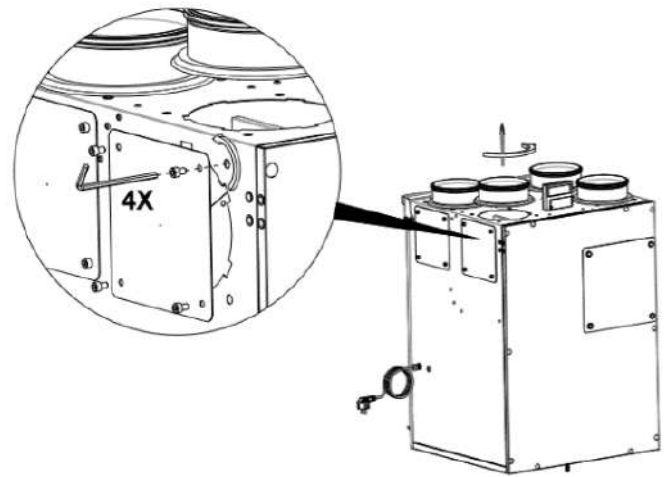

1. To remove side spigots: remove the retaining screws on relevant spigots lift off the unit.
2. Remove the blanking plates by unscrewing the 4 screws and lift off.
3. Install spigots to the relevant position on the side of the unit and secure with the 4 retaining screws.
4. Install the blanking plates to the exit hole on the upper side and secure with the 4 retaining screws.

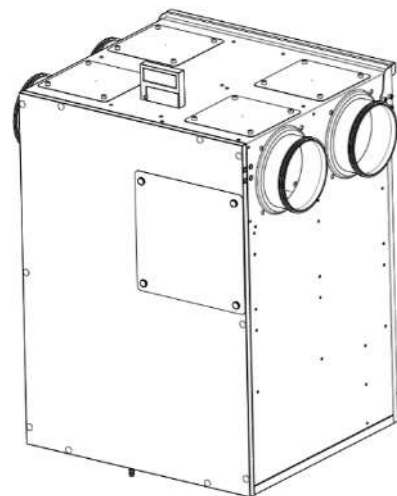





# 10. CONTROL

Operation	Description	Basic controller	Pro controller
Fan Speed Control	3 steps fan speed control of supply and exhaust fan is available.	3 steps (2 fans) (High/Med/Low)	3 steps (each fan) (High/Med/Low)
Boost Function	<b><u>Increases the fan speed:</u></b>  Alternative-1: Via boost button on the control board  Alternative-2: Via dry contact or light power input (230V) (like kitchen light, bathroom light etc.) on PCB board.	Standard	Standard
Filter Function	<b><u>There are 2 alternatives to control filters:</u></b>  Alternative-1: Records the run time of the unit and set time expires, the control board gives an alert for filter change.  Alternative-2: Filter change time can be controlled with pressure switch mechanically. With this method, when filter needs to be changed control board gives an alert .	Standard  Optional	Standard  Optional
By-Pass Function	Filtered fresh air is supplied indoor without passing in heat exchanger.	Standard	Standard
Sensor (VOD)	Fans are running continuously in accordance with CO2 sensor, air quality sensor or humidity sensor.	-----	Optional
Frost Protection Function	Where outdoor air is too low, this function is a protection method to prevent heat exchanger from freezing.	Standard	Standard
Modbus Function	It controls all functions of unit via PC or central automation board.	Standard	Standard
Weekly Timer Function	Unit can be programmed to operate on certain periods of the week. All possible working	-----	Standard
Warnings	- Filter change - Fan Fault - Pre-Heater Fault - Heater Fault	Standard (LED indicator)	Standard (Display error code)
Child-Proof Protection Function	It is used to lock the keypad.	Standard	Standard

## 10.1. Filter Function

This function controls filter change time. There are 2 options available:

1. Basic run time. The filter maintenance change time is factory set at particular run time by factory settings. When set time expires, controller will give an alert (red warning light flashes) for filter change. After filter maintenance/change is done, filter setting time can be reset by pressing simultaneously  and  on the digital controller; and hold  and  for 3 sec to reset filter time on the basic controller.

Note: Default run time set value is changeable when using the digital controller which is an optional controller.









2. Filter change time can be controlled by optional extra pressure switch mechanically. With this method, when filter needs to be changed, control board gives an alert (red warning light flashes). After changing/cleaning is completed, warning light goes off automatically.

## 10.2. By-pass Function

It is used when filtered fresh air is supplied indoors without passing through heat exchanger (hot seasons). The unit's PCB has built-in parameters to control the by-pass module which will be opened or closed by monitoring outdoor air temperature, return air temperature and set temperature values.







### Digital Controller

#### BUTTONS

Function	Button	Activity
Service operation	  	Press for 3 seconds
By-Pass function on/off [BYP]		Press for 3 seconds
Equipments function on/off (Heater, preheater) [HTI]		Press for 3 seconds
BMS function on/off [BMS]		Press for 3 seconds
Exit	  	Press for 3 seconds or Wait 10 seconds

### Basic Controller

#### LEDS

Led	Status	Status	Function
H	 On	 Off	By-Pass function [BYP]
M	 On	 Off	Equipments function (Heater, preheater) [HTI]
L	 On	 Off	BMS function [BMS]

 Led is off     Led is on     Blink



## 10.3. Frost Protection Function

Condensation occurs inside the unit where outdoor air temperature is below 0°C. The heat exchanger can be damaged if condensation water freezes inside it. The units PCB adjusts fan speeds periodically to protect freezing.

**Note:** This function is active when outdoor air temperature is below -3°C. Set temperature value is changeable using the digital controller only.

## 10.4. Boost Function

This function is used to increase supply and extract air flow when high levels of contamination are being produced (when cooking or taking a shower, etc.). There are 2 boost options available on controller. One of them is by using the controllers, the other one is through remote switches/boost switches wired in the unit's PCB.

1. "Boost" function is activated by pressing  on basic controller and  on digital controller for 3 seconds. When activated the unit runs at boost speed (maximum speed) for 15 minutes, after which the unit will return to its commissioned everyday running rate fan speed.

2. Remote switches can be connected to unit PCB (See wiring diagram). To activate and deactivate the boost function caution should be taken as this connection is rated at 230 V AC.



**Note 1:** Boost speed and boost time are changeable when using the digital controller only.

**Note 2:** During operating at boost function on basic controller, “high” (H), “medium” (M) and “low” (L) speed led are on at the same time.

## 10.4. Warnings

There are three types of warnings on basic controller:

1. If red warning signal light is continuous, this indicates fan failure or outdoor air thermistor failure. (Unit is not working.)
  2. If red warning signal and fan speed led lights simultaneously, this indicates failure of components. (Only fans are running.)
  3. If red warning signal flashes, it is an alarm of dirty filter.
- Screen failure code is “ERR” on digital controller. (See failure code list.)

**Note:** After troubleshooting, press  on basic controller and  on digital controller for 3 seconds.

## 10.5. Child Proof Protection Function

It is used to lock the keypad of the controller. (See use of keypad.)

**Note:** Child proof protection is available on digital controller.

## 10.6. Sensor (VOD) (Optional accessories)

Sensor (VOD) function is available on digital controller only. It runs with CO2 sensor, air quality sensor or humidity sensor. The fan speed changes automatically according to the information coming from these sensors.

The dry contact represents a volt free contact which is used, in this case, to boost the unit.

There is one dry contact relay input on the PCB. If the input is activated from a switch installed (turn on the switch), the unit will run at “boost” speed. When the input is passive again (turn off the switch), the unit runs at the speed value it was set before the switch was turned on. See input output connection below. For light switch connection, see relay contact connection below.

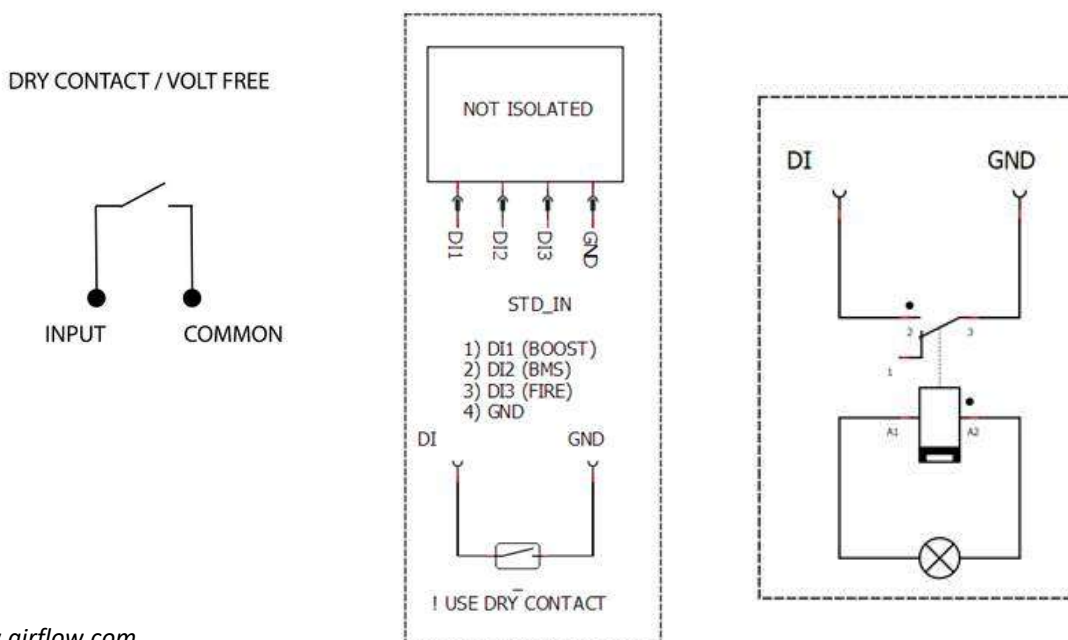

## 10.7. Basic Controller Functions



1. **ON/OFF:** Press for 3 seconds.

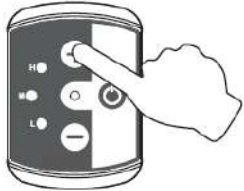

2. Press to increase fan speed.



3. Press to decrease fan speed.



4. Press to activate "boost" function.

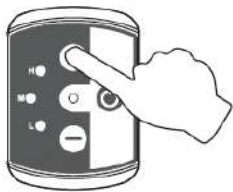

5. **Single Fan Mode (OA):** If you press for 3 seconds, RA fan will be off and OA fan will continue to run. At which step the fan is running, light of that fan speed starts to flash. To deactivate this mode, press or for 3 seconds.



6. **Single Fan Mode (RA):** If you press for 3 seconds, OA fan will be off and RA fan will continue to run. At which step the fan is running, light of that fan speed starts to flash. To deactivate this mode, press or for 3 seconds.



7. To reset the duration of filter contamination depending time, press and .

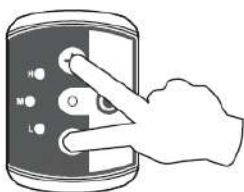

8. **Child Proof Protection:** To activate this function, press and for 3 seconds. When child proof protection is active, keypad is locked and buttons do not work. To deactivate this function press and for 3 seconds.



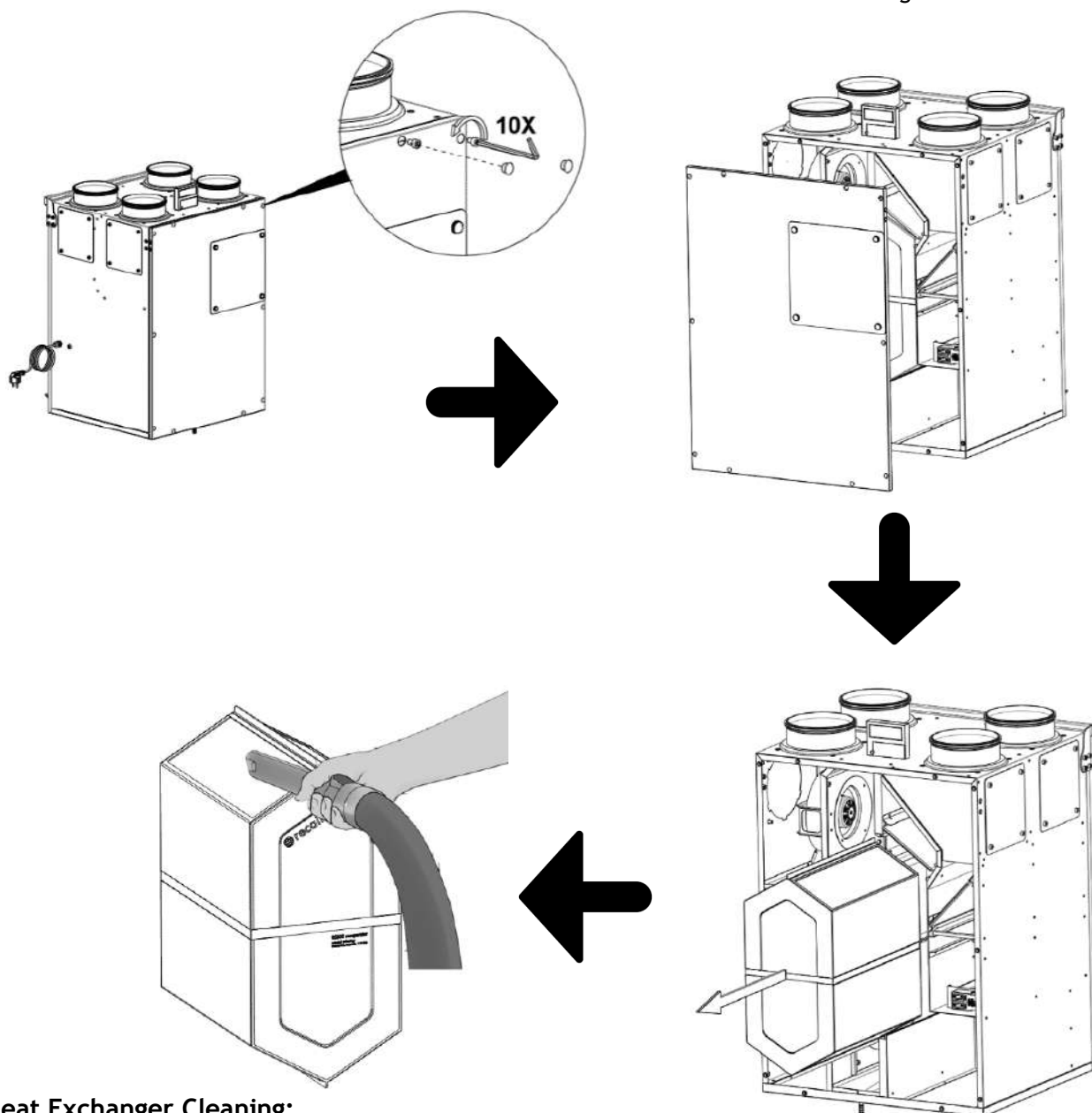

# 11. MAINTENANCE INSTRUCTIONS

## 11.1 Heat Exchanger Maintenance

The counter-flow heat exchangers installed in these units have no movable parts or metal connections; therefore, very little maintenance is required. It is recommended that the heat exchanger core to be cleaned on a regular basis. This will keep the efficiency of the unit at a high level. (Recommend inspection of core when filter maintenance/change takes place). Cleaning can be carried out by using a nozzle connection to a vacuum cleaner or by flushing with a warm mild detergent solution. Care should be taken not to damage the heat exchanger core.



### Heat Exchanger Cleaning:

-  Isolate unit before carrying out any work.
-  Work to be carried out only by a competent person.
-  Do not use corrosive, or aggressive cleaning agents.
-  Dust can best be removed from air inlet and outlet areas by using a normal vacuum cleaner.

## 11.2 Filter Maintenance

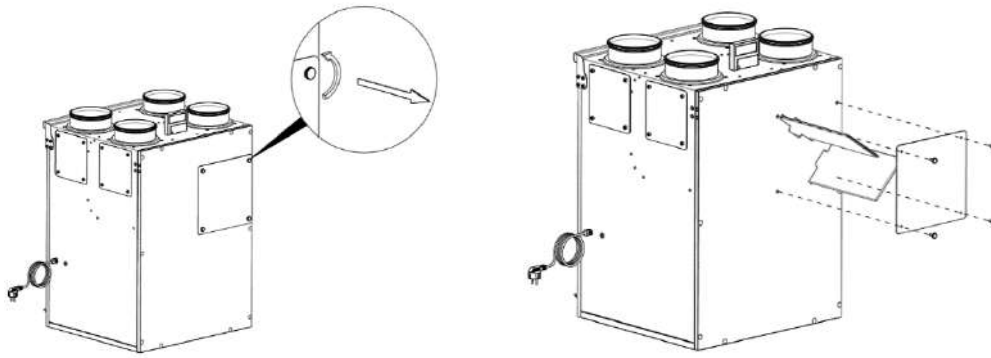

**Remove the air filter.** Turn the unit off. Clean the area around the service cover with a soft brush or vacuum before opening the vent indicated by labels. Remove the screw(s) Vacuum the encasement area, and take out the air filter.

**Cleaning the air filter.** Do not wash the filters. Clean the filters with vacuum. Filters must be changed after 3 cleanings. Change any damaged filters. If there are F7 filters, do not clean to F7 filters, and change them straightaway.

Install the filter into the chamber with the same instructions.

## 11.3 Fan Maintenance

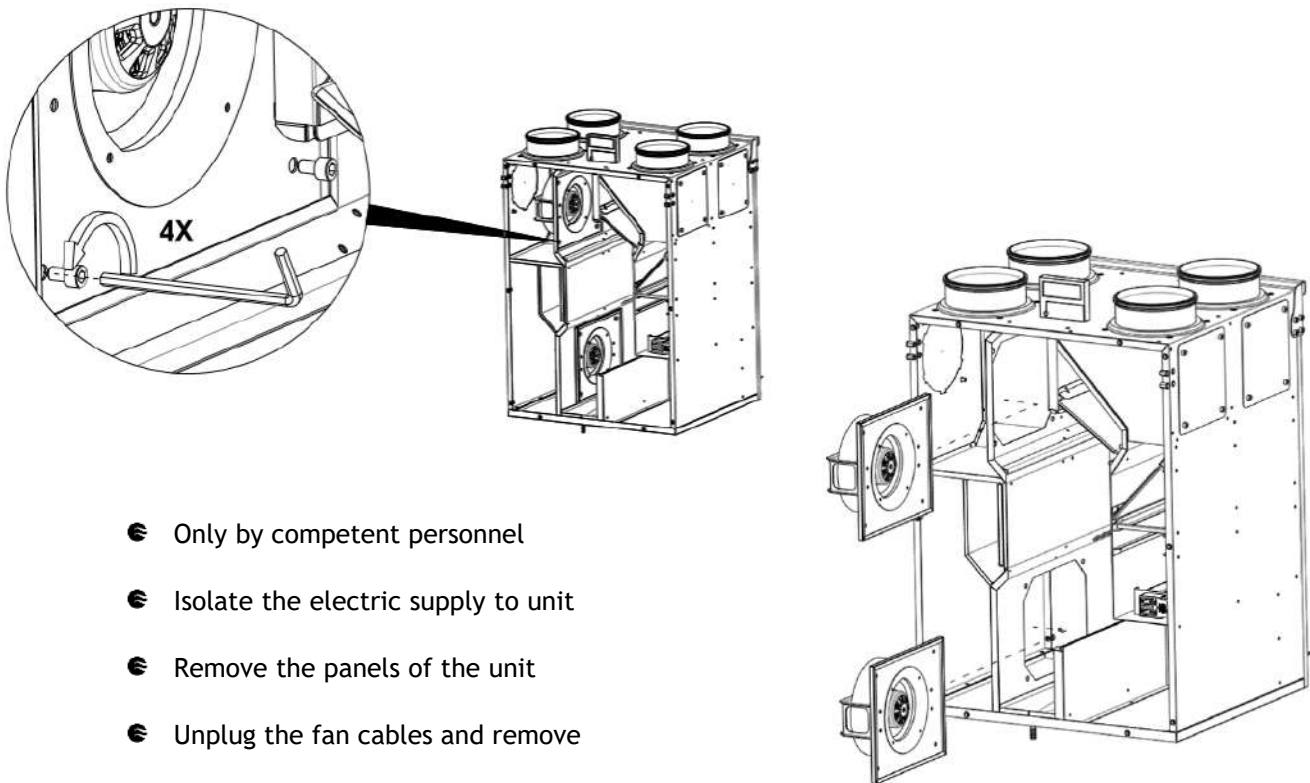

- ☛ Only by competent personnel
- ☛ Isolate the electric supply to unit
- ☛ Remove the panels of the unit
- ☛ Unplug the fan cables and remove the fans
- ☛ Clean fans with soft brush or vacuum

## 12. OPERATING INSTRUCTIONS

Continuous ventilation is necessary to ensure a healthy indoor air quality and to maintain the building fabric in good condition at all times. Even with prolonged absence of residents (i.e. holiday) it is not recommended to switch off the ventilation unit since indoor contaminants are still being produced and entering the air, causing the air to get stuffy and a high possibility of moisture damage due to excess humidity during the heating season.

The ventilation unit works properly when the flow rates are adjusted in accordance with the above regulations to ensure optimum ventilation of the house.



### Electrical Connections

Mains supply voltages (230 V AC) are present in this equipment which may cause death or serious injury by electric shock. Only a qualified electrician or installer should connect the power supply to this unit. This unit must be correctly earthed. Do not connect any accessories or ancillaries, such as the controller or any additional sensors unless the unit is down powered and isolated from mains electricity supply.

By default, the fans are set-up at the following speeds:

Basic controller	Fresh air fan speed	Exhaust air fan speed
High	80%	60%
Medium	55%	40%
Low	30%	20%

## 13. CONTROL FUNCTIONS

Operation	Description	Availability
ON / OFF	Control panel or external start-stop function is available.	Standard
Display	Digital control panel is available.	Standard
Display	Wireless controller is available as option.	Optional
Fan Speed Control	3 steps fan speed control of supply and exhaust fan is available.	Standard
Fan Speed Control	Constant air flow is available with pressure sensors.	Optional
Fan Speed Control	Airflow control based on the air quality sensor is available.	Optional
Bypass Damper Function	Free cooling is available by controlling the indoor and outdoor air conditions.	Standard
Front Protection Function	Where outdoor temperature is low, this function will be active by receiving information humidity and temperature sensors.	Standard
Modbus	It controls all functions of unit via PC or central control system board.	Standard
Filter Function	<p><b>There are 2 alternatives to control filters:</b></p> <p><b>Alternative 1:</b> It records run time of the unit and when set times expires, control panel gives an alert for filter change.</p> <p><b>Alternative 2:</b> Filter change time can be controlled with pressure switch mechanically. By this way, control panel gives alert when filters need alert when filter needs to be changed.</p>	Standard
Boost Function	<p><b>It is used in order increase fan speed:</b></p> <p><b>Alternative 1:</b> Via boost button on the control panel.</p> <p><b>Alternative 2:</b> Via dry contact or light power input(230 V) on PCB board.</p>	Standard
Safety	It automatically stops operating in case of interfering to the unit while at.	Standard
Fire Alarm Function	It will be active case of fire	Standard
Wireless Sensors	Upon request, wireless CO2 differential pressure, temperature and humidity sensors are available.	Optional

## 14. TROUBLESHOOTING

Failure	Reason	Solution
Outdoor air coming into the dwelling is cold.	<ul style="list-style-type: none"> <li>•Air cools down in the attic ducts"</li> <li>•The heat exchangers frozen which is why extract air cannot heat the incoming air.</li> <li>•The extract fan is not running.</li> <li>•The extract air filter or the heat exchanger is clogged.</li> </ul>	<ul style="list-style-type: none"> <li>✓ Check the duct insulation</li> <li>✓ If the heat exchanger frozen contact your supplier/installer to reduce the set point of the frost protection facility</li> <li>✓Contact your supplier/installer.</li> <li>✓ Check that the filters and the heat exchanger are clean.</li> </ul>
The unit has been switched off unexpectedly.	<ul style="list-style-type: none"> <li>•Mains voltage failure</li> </ul>	<ul style="list-style-type: none"> <li>✓Consult a qualified electrician to check mains power supply to units.</li> </ul>
The unit makes a lot of noise.	<ul style="list-style-type: none"> <li>Rumbling/Ratting noise</li> <li>Fan motor fault</li> </ul>	<ul style="list-style-type: none"> <li>✓Contact your supplier/installer.</li> </ul>
Water leakage near the unit.	<ul style="list-style-type: none"> <li>Condensate trap is clogged of frozen.</li> <li>Condensate pipe is has come loose.</li> </ul>	<ul style="list-style-type: none"> <li>✓Check the condensate drain and clean it, if necessary change it.</li> </ul>
Unpleasant smell near the unit.	<ul style="list-style-type: none"> <li>Condensate trap (U-bend) below the unit is empty.</li> <li>The condensate pipe is not completely in the trap.</li> <li>The condensate pipe or condensate trap is blocked of frozen.</li> </ul>	<ul style="list-style-type: none"> <li>✓Fill the condensate trap with water.</li> <li>✓Push the pipe deeper into the trap.</li> <li>✓Check the condensate drain and clean it, if necessary</li> </ul>

# WIRING DIAGRAM

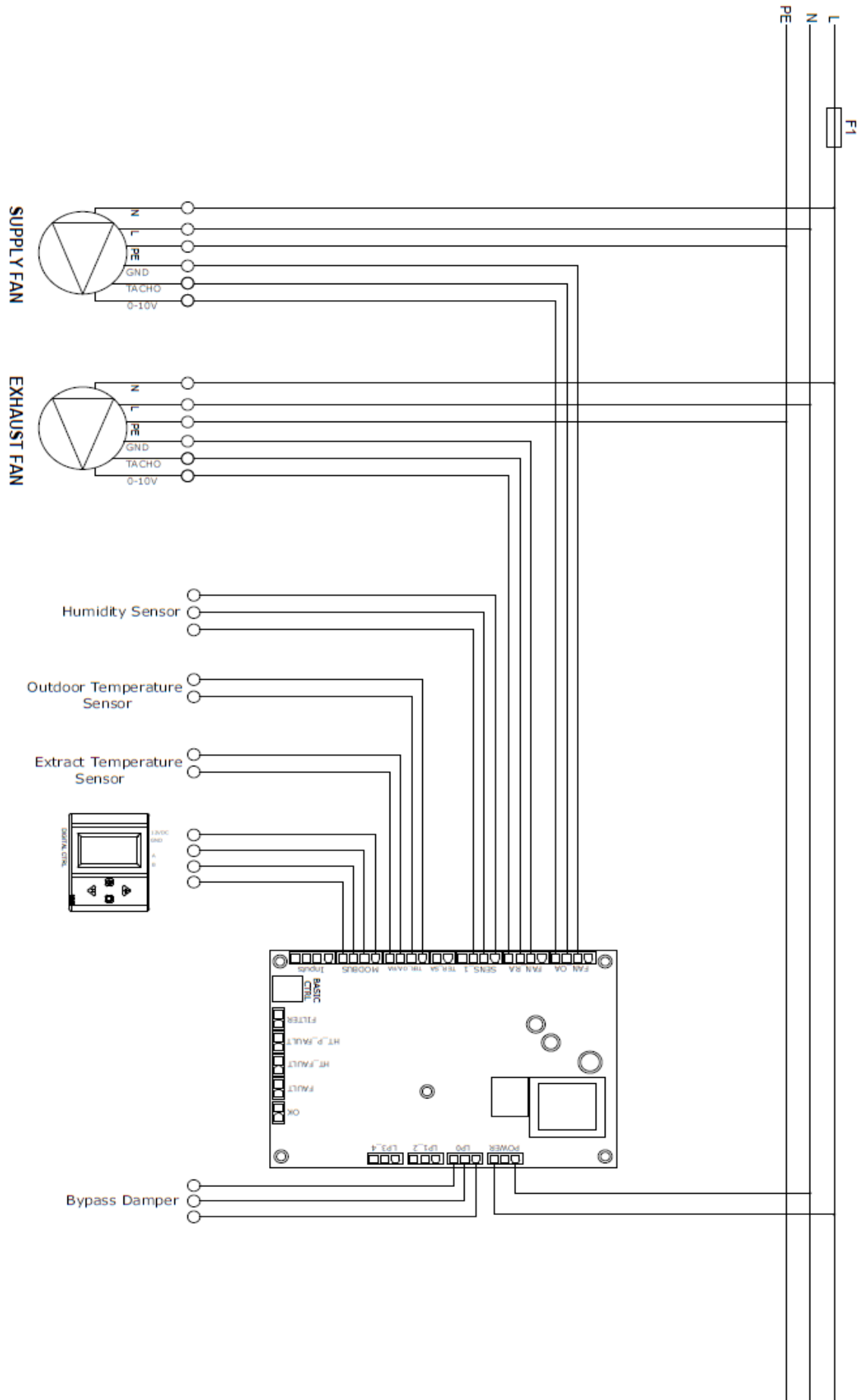



**Airflow Developments Limited**  
Aidelle House, Lancaster Road  
Cressex Business Park, High Wycombe  
Buckinghamshire, HP12 3QP, U.K

E: [infor@airflow.com](mailto:infor@airflow.com)  
T: 44(0)1494 525252  
W: [airflow.com](http://airflow.com)