

YOUR INSTALLATION GUIDE



GLASS UNLIMITED

INTERIOR GLASS APPLICATIONS

COMPANY

Based in Brussels, AGC Glass Europe produces, processes and distributes flat glass for the construction industry (external glazing and decorative indoor glass), the automotive industry, the solar industry, and specialist industries⁽¹⁾. It is the European branch of AGC Glass, one of the leading producers of flat glass.

Its baseline "Glass Unlimited" reflects the possibilities offered by:

- glass as a material to meet a growing variety of needs (comfort, energy control, health & safety, aesthetics);
- innovation in products and processes, derived from sustained research into advanced glass technology;
- industrial facilities comprising 18 float plants, 6 automotive glass plants and more than 100 processing and distribution units throughout Europe, from Spain to Russia;
- a worldwide marketing network;
- the resources of its personnel, motivated by operational excellence and innovation.

AGC Glass Europe currently employs some 15,000 people.

GLASS ACCESSORIES

AGC⁽²⁾ develops and manufactures its products under modern, advanced and scientifically controlled conditions. This, combined with AGC's ongoing efforts to continually improve quality, means that the company can offer a 5-year warranty on Lacobel, Matelac and Mirox products, and a 10-year warranty on Lacobel T. This warranty applies only if FIX-IN products have been used in full

compliance with this Installation Guide. AGC is not responsible for products or materials produced or supplied by third parties.

This Installation Guide reflects AGC's knowledge and experience at the time of publication. Every version of the Installation Guide bears a reference to its publication date. The newest version of the Installation Guide replaces all previous versions. Customers should be aware that the newest version may contain technical changes that must be taken into account when using FIX-IN products with the above-mentioned glass products.

The latest version of the Installation Guide and our warranty may be consulted on www.yourglass.com or obtained from your local AGC representative. Customers should always check whether an updated version of the Installation Guide is available before using AGC glass products.

AGC's warranty on glass products shall only apply if the latest version of this Installation Guide, which may be updated from time to time, is used by the customer and if all relevant requirements, standards and regulations have been taken into account by the customer for the use of the glass products.

AGC has made every effort to ensure the accuracy of the information in this Installation Guide, but it cannot be held liable for any oversights, inaccuracies or typographical errors.

The Installation Guide and our warranty terms are available in multiple languages. Please consult www.yourglass.com or contact your local AGC representative to view or receive the Installation Guide in other languages.

RAW MATERIALS

Flat glass used in buildings is made from a mixture of soda lime (soda + lime) and silica (silica or sand) obtained by melting the materials at high temperature.

Soda-lime-silica glass is made of:

Silica sand

- used to give the glass its texture. This is known as the glass former or SiO₂ network former.

Soda

- used as a melting agent to lower the melting point of the silica and as a fining agent to homogenise the mixture and eliminate bubbles.

Calcium carbonate

- used as a stabiliser, giving the glass its chemical resistance.

Fining agents

- designed to agitate the mixture, thereby releasing gases and standardising quality.

Metal oxides

- used to enhance the mechanical characteristics of the glass, its resistance to atmospheric agents and give it any colouring it might have.

AGC Glass Europe
Avenue Jean Monnet 4
1348 Louvain-la-Neuve, Belgium

(1) Transport industry (glazing for ships and railway/subway carriages), domestic appliances and high-tech applications

(2) In this document, AGC means AGC Glass Europe with registered offices at Avenue Jean Monnet 4, 1348 Louvain-la-Neuve, Belgium, registered with the register of legal entities (Nivelles) under No. 0413.638.187, or a controlled undertaking (as defined under Article 2.1(f) of European Directive 2004/109/EC) of AGC Glass Europe to the extent such controlled undertaking has sold the products referred to herein



CONFERENCE AND OFFICE BUILDING

1 INTERIOR GLASS PRODUCTS

1.1	Glass and the endless interior applications	4
1.2	Product description	5
1.3	Colours and textures	6
1.4	Lacobel - Opaque painted glass	10
1.5	Matelac - Matt surface - Opaque painted glass	12
1.6	Mirox - Silver coated Mirrors	14
1.7	Lacobel T / Matelac T - Temperable - Opaque enamelled glass	16
1.8	Product Data	18
1.9	Additional treatment - AntiBacterial™ Glass	19
1.10	Additional treatment - SAFE and SAFE+ backing film	21

2 SAFETY

2.1	Safety - Tests and Regulations	22
2.2	Fire Performance	22

3 PREPARATION AND FINISHING

3.1	Substrates and Substructures	23
3.2	Edge finishing	25
3.3	Corners	26
3.4	Cutting and Drilling	27

4 FIXING SYSTEMS

4.1	Installation Systems	28
4.2	Fitting Systems	30

5 SILICONE FIXING

5.1	FIX-IN SL silicone	31
5.2	FIX-IN SL silicone for Mirox	36

6 SILICONE APPLICATIONS

6.1	FIX-IN SL silicone for furniture	38
6.2	FIX-IN SL silicone for humid areas	40
6.3	FIX-IN SL silicone for splashbacks	41
6.4	FIX-IN SL silicone for elevators	42
6.5	FIX-IN SL silicone for prefabricated panels	44
6.6	FIX-IN SL silicone for renovation	46

7 MECHANICAL FITTING

48

8 CLEANING

50

9 MISTAKES

52

10 PRESCRIPTION - GLASS PRODUCTS

10.1	Specifications	54
10.2	Specifications - Functional Description and Installation	56

11 APPENDIX

11.1	Disclaimer	57
11.2	Index of Sections	58



SPECIAL GLASS



SOLAR PANELS



EXTERIOR CLADDING

INTERIOR GLASS APPLICATIONS

The purpose of these guidelines is to inform architects, designers and glaziers about the interior applications of painted and silvered glass.

We focus on the most important information you need to plan and execute your project perfectly.

However, project owners are responsible for ensuring their plans conform to local requirements, standards and regulations.

IMPORTANT

Lacobel, Matelac and Mirox (with and without SAFE and SAFE+ backing film) have been designed for use in interior applications exclusively.

The production process, tested applications and AGC's recommended bonding systems are ideal for interior use.

LACOBEL T / MATELAC T

Lacobel T / Matelac T can be used in both interior and exterior applications. The obligatory heat treatment not only makes Lacobel T / Matelac T highly resistant to heat differences within the sheet, but also enhances their mechanical and thermal strength. Lacobel T / Matelac T will not break as a result of thermal shock caused by solar radiation or other heat sources, such as gas stoves.

RESTRICTIONS

Restrictions may apply to some applications, even interior applications. Glass subjected to heat or extended contact with water and corrosive substances cannot be expected to offer full performance.

Lacobel, Matelac and Mirox should not be installed near open fires and heat sources (such as gas stoves), nor in or near pools and saunas. These glass types should not be used as a flooring material nor be immersed in water.

Lacobel, Matelac and Mirox cannot be used in double glazing, insulated glass or laminated glass. Since the glass cannot be tempered, it is sensitive to thermal shock and other stresses.

For Lacobel T / Matelac T almost no restrictions apply once they are tempered.

Decorative interior glass products are not designed to be backlit.

1.1 GLASS AND THE ENDLESS INTERIOR APPLICATIONS



CONFERENCE CENTERS



OFFICE SPACES



EDUCATIONAL FACILITIES

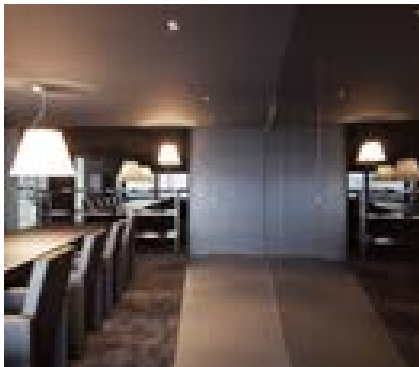

HOTEL INTERIORS



RESTAURANT



WASHROOMS



SHOPPING CENTRES



RETAIL STORES



FURNITURE AND INTERIORS



HOSPITALS AND CLEAN ROOMS



TRANSPORT FACILITIES

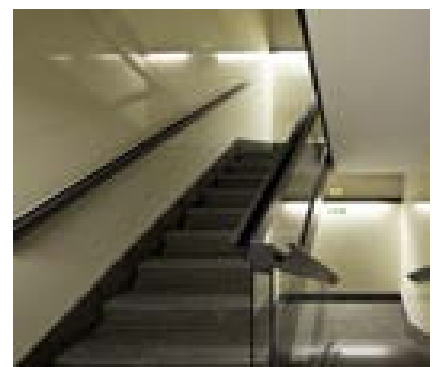

SPORT AND LEISURE FACILITIES

1.2 PRODUCT DESCRIPTION

LACOBEL

- Surface:** Untreated glass surface, shiny, slightly reflective appearance
- Material:** Float glass, painted back
- Transparency:** Opaque
- Colours:** 25 standard colours
Custom colours available, minimum order 200 m²
- Safety:** Standard product has float glass properties
SAFE and SAFE+ backing film on request
EN 12600, class B
- AntiBacterial™:** On request



LACOBEL

MATELAC

- Surface:** Acid-etched glass surface, matt, satin look
- Material:** Float glass, etched front, painted back
- Transparency:** Opaque
- Colours:** 12 standard colours
- Safety:** Standard product has float glass properties
SAFE and SAFE+ backing film on request
EN 12600, class B
- AntiBacterial™:** No



MATELAC

LACOBEL T / MATELAC T

- Surface:** Untreated glass surface, shiny, slightly reflective appearance for Lacobel T
Acid-etched glass surface, matt, satin appearance for Matelac T
- Material:** Float glass, acid-etched in case of Matelac T, with enamelled (painted) back, tempered
- Transparency:** Opaque, Crisp White slightly translucent
- Colours:** 15 standard colours
- Safety:** After tempering
- AntiBacterial™:** No

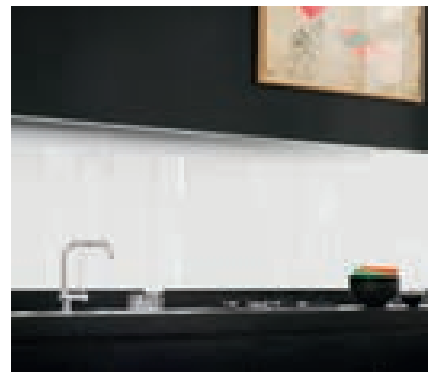

LACOBEL T

MIROX

- Surface:** Untreated glass surface, shiny, reflective appearance
- Material:** Silvered float glass
- Transparency:** Opaque
- Colours:** 8 variations
- Safety:** Standard product has float glass properties
SAFE and SAFE+ backing film on request
EN 12600, class B
- AntiBacterial™:** On request



MIROX

1.3 COLOURS AND TEXTURES

STANDARD COLOURS

AGC has produced thousands of different colours over the years.

Of these colours some standard stock ranges have been developed in consultation with architects, designers and specialists in this field.

Products in the standard colours are kept in stock at our factories and with our dealers.

Customers who opt for glass in standard colours can receive their order quickly thanks to AGC's extensive distribution network.

CUSTOM COLOURS

In addition to the standard colour range for Lacobel, AGC can easily produce almost any other colour needed.

All RAL and NCS colours, as well as any other tone, can be applied to the glass.

Customers can even provide a colour swatch that AGC can use as a reference.

Custom metallic and Matelac colours are not available.

The minimum order size for custom colours is 200 m². Production time after confirmation of the colour is approximately 4 weeks.

COLOUR SAMPLES

While excellent results can be achieved by matching glass to RAL (and other) colours, AGC recommends choosing a colour exclusively on the basis of an original factory-made glass sample.

Colour reproductions seen in colour charts, brochures and catalogues simply cannot perfectly represent the final colour of the glass product.

Please note that the colour is influenced by various factors, including the natural colour of the glass. In other words, slight colour variations may occur.

Clearvision glass can be used in order to minimise the influence of the glass on the final colour.



STANDARD COLOURS

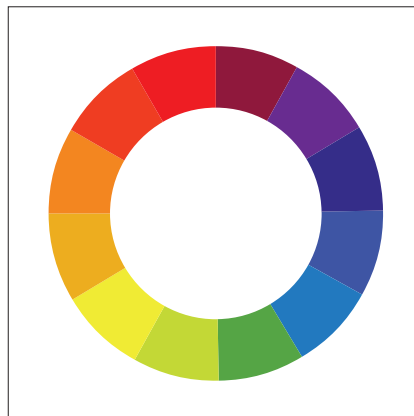

CUSTOM COLOURS

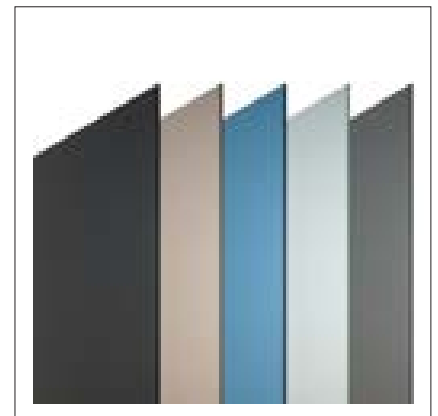

COLOUR SAMPLES

LACOBEL: COLOUR CHART

25 standard colours
Custom colours on request



Beige Classic (S-W)
Ref 1014



Beige Light
Ref 1015



Black Classic
Ref 9005



Blue Pastel
Ref 1603



Brown Dark
Ref 8017



Brown Light
Ref 1236



Fuchsia (S-W)
Ref 4006



Green Luminous
Ref 1164

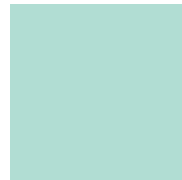

Green Pastel
Ref 1604



Grey Classic
Ref 7035



Grey Metal (S-F)
Ref 9006



Taupe Metal (S-F)
Ref 0627



Orange Classic (S-W)
Ref 2001



White Pearl (S-W)
Ref 1013



White Pure (S-W)
Ref 9003



Red Dark
Ref 3004



Red Luminous (S-W)
Ref 1586



Aluminium Rich (S-F)
Ref 9007

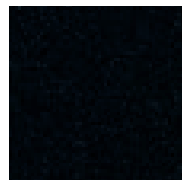

Black Starlight (S-F)
Ref 0337

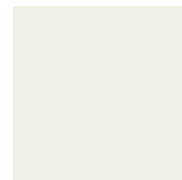

White Soft (S-W)
Ref 9010



Anthracite Authentic
Ref 7016

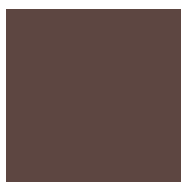

Brown Natural
Ref 7013



Blue Petrol
Ref 5001



Yellow Rich (S-W)
Ref 1023



Blue Shadow
Ref 7000

(S-F) = Only with silicon bonding and SAFE and SAFE+ backing film in humid area
(S-W) = For silicon bonding only to be applied on uniform white painted background

1. INTERIOR GLASS PRODUCTS

MATELAC: COLOUR CHART

12 standard colours



Black Classic
Ref 9005



Orange Classic (S-W)
Ref 2001



Grey Metal (S-F)
Ref 9006



White Pure (S-W)
Ref 9003



Silver Bronze



Silver Grey

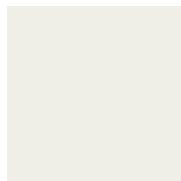

White Soft (S-W)
Ref 9010



Anthracite Authentic
Ref 7016

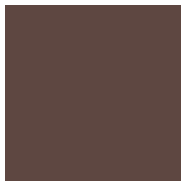

Brown Natural
Ref 7013



Blue Shadow
Ref 7000



Yellow Rich (S-W)
Ref 1023



Silver Clearvision

LACOBEL T / MATELAC T: COLOUR CHART

15 standard colours

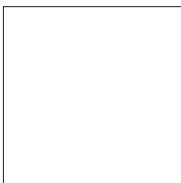

Crisp White (M)
Ref 1000



Cool White
Ref 1502



Zen Grey
Ref 6005



Deep Black
Ref 8502



Oyster White
Ref 0613

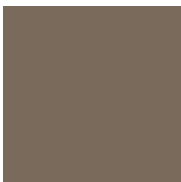

Moka
Ref 3113



Anthracite Grey
Ref 0913



Mustard Yellow
Ref 2313



Royal Blue
Ref 0513



Light Blue
Ref 1413



Burgundy Red
Ref 1113

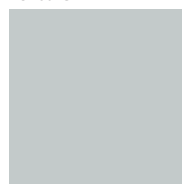

Misty White
Ref 5813



Petrol Green
Ref 1313



Apple Green
Ref 1229

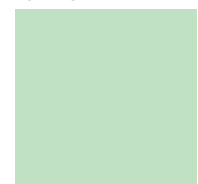

Light Green
Ref 5713

(S-F) = Only with silicon bonding and SAFE and SAFE+ backing film in humid area
 (S-W) = For silicon bonding only to be applied on uniform white painted background
 (M) = Mechanical fixing only

UV RESISTANCE

The UV resistance of the paint used is very high, ensuring colour stability.

PROJECTS

To ensure an identical colour across a given project, AGC recommends using glass made from a single production batch.

THICKNESS OF THE GLASS

For most applications a glass thickness of 6mm is sufficient. A different thickness may be necessary depending on the sheet size, substrate and related requirements.

The thickness of the float glass sheet also has a slight impact on the colour, possibly resulting in colour variations. Consequently, using different thicknesses of glass next to each other should be avoided.

The colour is always visible through the glass since the back of the glass is painted.

ORIENTATION OF THE GLASS SHEETS

Most colours are applied isotropically. This means that the coating does not have a 'direction' or 'orientation'. This presents two advantages when installing the glass. Firstly, since the entire sheet can be used, cutting can be organised very efficiently, thus minimising waste. Secondly, during the planning and installation phase no particular care must be taken to install the glass in a particular direction.

Some colours are an exception. Due to the special pigments used for some colours, they have a specific orientation. This must be taken into consideration during planning, processing and installation.

These colours are:

Lacobel: Grey Metal, Metal Taupe, Starlight Black, Rich Aluminium

Matelac: Grey Metal

BACK OF THE GLASS

Paint and/or a SAFE and SAFE+ backing film is applied to the back of the glass.

In either case, the back is not meant to be visible.

TOUCH-UP PAINT

Small scratches and damages on the painted side of the glass due to handling for processing or installation can be repaired using AGC's FIX-IN TU Touch-up paint for standard colours, available at www.agc-store.com.

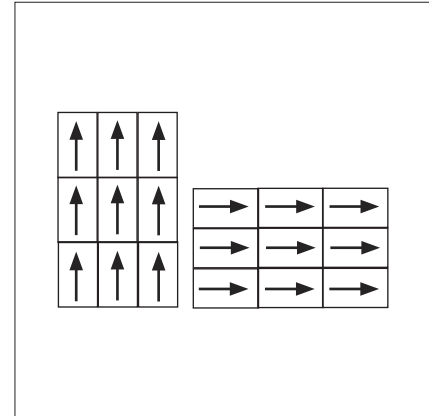

ORIENTATION OF GLASS SHEETS

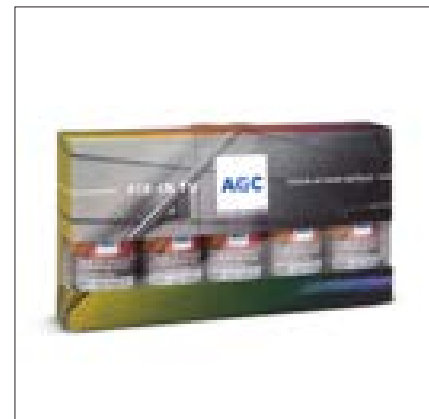

FIX-IN TOUCH-UP PAINT

1.4 LACOBEL - OPAQUE PAINTED GLASS

LACOBEL: INTERIOR USE

- Wall coverings
- Table tops
- Shelves
- Sliding doors in frames
- Cupboards
- Wardrobes
- Display cases

LACOBEL: FITTING

- FIX-IN SL Silicone adhesive (see colour charts for restrictions)
- Mechanical fitting

LACOBEL: EXTERIOR USE

The product is not designed for use in exterior applications.

LACOBEL: PRODUCTION

Lacobel consists of clear float glass (1), giving the product a shiny, flat surface. The back is coated with an opaque organic paint (2) to create the desired colour. The appearance is shiny and slightly reflective.

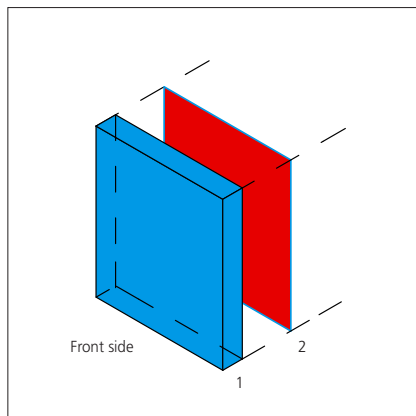

LACOBEL: PRODUCTION



FIXATION

LACOBEL: PROPERTIES

AntiBacterial™ on request.

SAFE and SAFE+ backing film on request.

With SAFE and SAFE+ backing film: safety glass according EN 12600 class B.

LACOBEL: MOISTURE RESISTANCE

All Lacobel colours can be used in humid environments (bathrooms and kitchens) provided water does not penetrate behind the glass. This product is not designed to be used in or near pools and saunas.

To protect the glass from water, different factors must be taken into account during installation.

Silicone bonding, mechanical fitting:

Silicone bonding or mechanical fitting can be used with all colours, but for some colours (indicated in the colour charts of Lacobel and Matelac) the SAFE and SAFE+ backing film must be used to provide additional protection for the back of the glass in humid areas.

Lacobel: Availability

Dimensions in cm	Thickness in mm	Other dimensions	Installation	Product	Colours	Custom colours
225 x 321 600 x 321	3, 4, 5, 6, 8, 10 Others on request	On request	Silicone* Mechanical fitting	FIX-IN SL -	25 standard colours	Yes, minimum order 200m ² per colour

* Restrictions apply: See colour charts

FOR MORE INFORMATION, SEE PAGE 18



LACOBEL

1.5 MATELAC - MATT SURFACE - OPAQUE PAINTED GLASS

MATELAC: INTERIOR USE

- Wall coverings
- Table tops
- Shelves
- Sliding doors in frames
- Cupboards
- Wardrobes
- Display cases

MATELAC: INSTALLATION FITTING

- FIX-IN SL Silicone adhesive (see colour charts for restrictions)
- Mechanical fitting

MATELAC: EXTERIOR USE

The product is not designed for use in exterior applications.

MATELAC: PRODUCTION

Matelac consists of acid-etched (1) clear float glass (2), which gives the product its matt surface. The back is coated with an opaque organic paint (3) to create the desired colour.

Matelac has a satin finish.

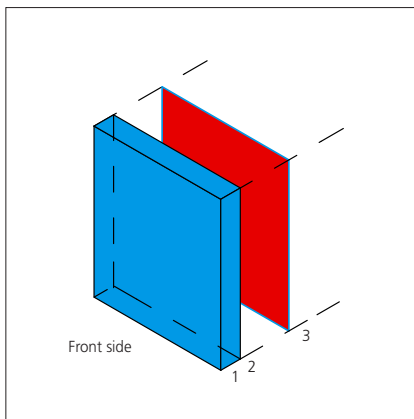

MATELAC: PRODUCTION

MATELAC: PROPERTIES

AntiBacterial™ version: There is no AntiBacterial™ version due to the acid-etched surface.

SAFE and SAFE+ backing film on request.

With SAFE and SAFE+ backing film: safety glass according EN 12600 class B.

MATELAC: MOISTURE RESISTANCE

All Matelac colours can be used in humid environments (bathrooms and kitchens) provided water does not penetrate behind the glass. This product is not designed to be used in or near pools and saunas.



FIXATION

To protect the glass from water, different factors must be taken into account during installation.

Silicone bonding, mechanical fitting:

Silicone bonding or mechanical fitting can be used with all colours. However, for some colours (indicated in the colour charts of Lacobel and Matelac) a safety film must be used to provide additional protection for the back of the glass in humid areas.

Matelac: Availability

Dimensions in cm	Thickness in mm	Other dimensions	Installation	Product	Colours	Custom colours
225 x 321 255 x 321	4, 6 Others on request	On request	Silicone* Mechanical fitting	FIX-IN SL -	12 standard colours	No

* Restrictions apply: See colour charts

FOR MORE INFORMATION, SEE PAGE 18



MATELAC

1.6 MIROX - SILVER COATED MIRRORS

MIROX: INTERIOR USE

- Wall coverings
- Table tops
- Shelves
- Sliding doors in frames
- Cupboards
- Wardrobes
- Display cases

MIROX: FITTING

- FIX-IN SL Silicone adhesive
- Mechanical fitting

MIROX: EXTERIOR USE

The product is not designed for use in exterior applications.

MIROX: PRODUCTION

The reflective effect of Mirox products is created via an AGC patented process consisting of one layer of silvering (2) and an additional protective layer (3) on the back of the clear float glass (1).

All materials used are environmentally friendly and provide enhanced resistance to corrosion and ageing.

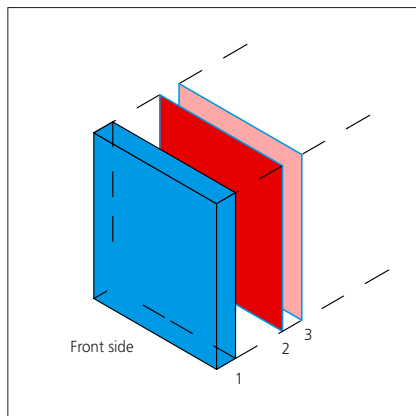

MIROX: PRODUCTION



FIXATION

MIROX: PROPERTIES

Mirox products offer excellent performance in all durability tests (as per EN 1036-1).

AntiBacterial™ on request.

SAFE and SAFE+ backing film on request.

With SAFE and SAFE+ backing film : safety glass according EN 12600 class B.

MIROX: MOISTURE RESISTANCE

All Mirox colours can be used in humid environments (bathrooms and kitchens) provided water does not penetrate behind the glass. This product is not designed to be used in or near pools and saunas.

To protect the glass from water, different factors must be taken into account during installation.

Silicone bonding, mechanical fitting:

Silicone bonding or mechanical fitting (with or without the SAFE and SAFE+ backing film) can be used with all variants.

Mirox: Availability

Dimensions in cm	Thickness in mm	Other dimensions	Installation	Product	Colours	Custom colours
225 x 321 255 x 321 600 x 321	3, 4, 5, 6	On request	Silicone Mechanical fitting	FIX-IN SL -	8 variations	No

FOR MORE INFORMATION, SEE PAGE 18



MIROX

1.7 LACOBEL T / MATELAC T - TEMPERABLE OPAQUE ENAMELLED GLASS

INTERIOR USE

- Wall coverings
- Table tops
- Tables
- Shelves
- Fixed doors and sliding doors
- Display cases and glass bases - Full glass doors
- Laminated glass

FITTING

- FIX-IN SL Silicone adhesive (See colour charts for restrictions)
- Mechanical and point fitting

EXTERIOR USE

Lacobel T / Matelac T can be used in both interior and exterior applications, please see special guidelines from AGC for external fitting.

PRODUCTION

With Lacobel T / Matelac T, AGC combines its existing ranges of high-quality decorative glass with the best safety standards for single layer glasses available today. To achieve this, an enamel paint (2) is applied to the back of the float glass (1) prior to tempering.

Tempering (a process involving the heating and controlled cooling of glass) improves the mechanical, thermal and safety properties of the glass.

Any cutting, drilling and edge finishing must be done prior to tempering.

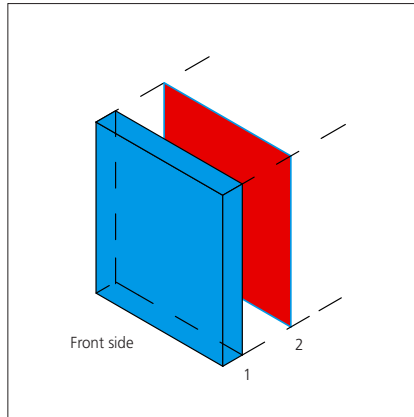

LACOBEL T: PRODUCTION



FIXATION

PROPERTIES AFTER TEMPERING

Heat resistance:

Up to 200° C temperature difference within the sheet.

Opacity: All colours are opaque, except Crisp White which is slightly translucent. When using silicone to install the glass, please choose Cool White instead of Crisp White to avoid visible fixing points.

AntiBacterial™ version:

Not available.

SAFE and SAFE+ backing film: not available.

Bending:

For bending, please consult the processing guide on www.yourglass.com.

Lamination (glass-film-glass) is possible on both sides for Lacobel T and on the painted side for Matelac T (e.g. sliding doors, which are visible on both sides).

MOISTURE RESISTANCE

All Lacobel T / Matelac T colours can be used in humid and wet environments (bathrooms and kitchens). Even though these products are water-resistant, the painted side should not be permanently exposed to water, and care must be taken to prevent water from penetrating behind the glass as it might destroy the wall construction.

Lacobel T / Matelac T: Availability

Dimensions in cm	Thickness in mm	Other dimensions	Installation	Product	Colours	Custom colours
225 x 321 255 x 321	4, 6, 8***, 10***	On request	Silicone*	FIX-IN SL**	15 standard colours	No
510 x 321***	4, 6, 8					

* Restrictions apply: See colour charts
 ** FIX-IN SL is for interior applications only
 *** Only available for Lacobel T

FOR MORE INFORMATION, SEE PAGE 18



LACOBEL T

1.8 PRODUCT DATA

Products and specifications

	Lacobel	Matelac	Mirox***	Lacobel T / Matelac T
Material	Untreated shiny surface, float glass, painted back	Acid-etched matt surface, float glass, painted back	Untreated shiny surface, float glass, layers of silvering on back	Untreated shiny surface (Lacobel T) or acid etched matt surface (Matelac T), float glass, painted back, tempered
Standard thickness mm	4, 6	4, 6	3, 4, 5, 6	4, 6, 8, 10
Standard dimensions cm	225 x 321 255 x 321	225 x 321 255 x 321	225 x 321 255 x 321 600 x 321	225 x 321 255 x 321 510 x 321
Other thicknesses	On request	On request	On request	On request
Standard colours	25 standard	12 standard	8 standard	15 standard
Custom colours	Yes, minimum order 200 m ² per colour	No	No	No
AntiBacterial™ glass	On request	No	On request	No
SAFE and SAFE+ backing film, transparent film	For all standard dimensions	For all standard dimensions	For 225-255 x 321 dimensions	No
Heat resistance	Paint: up to 80°C Glass: up to 30°C difference within the sheet	Paint: up to 80°C Glass: up to 30°C difference within the sheet	Paint: up to 120°C Glass: up to 30°C difference within the sheet	After tempering: Paint: up to 200°C Glass: up to 200°C difference within the sheet
FIX-IN systems*	Silicone*	Silicone*	Silicone*	Silicone*
Mechanical fitting	Mechanical fitting, frames, clamps	Mechanical fitting, frames, clamps	Mechanical fitting, frames, clamps	Point and mechanical fitting, frames, clamps
EN 12600 classification with SAFE and SAFE+ backing film	Safety glass acc EN 12600, class B	Safety glass acc EN 12600, class B	Safety glass acc EN 12600, class B	
Reaction to fire performance EN 13501 - 1 Not installed	A1 (except specific colours****)	A1 (except specific colours****)	A1	A1
Reaction to fire performance EN 13501 - 1 with SAFE and SAFE+ backing film Not installed	A2,s1-d0 (except specific colours****)	A2,s1-d0 (except specific colours****)	A2,s1-d0	n/a
Reaction to fire performance EN 13501 - 1** installed, Silicone adhesive	B,s1-d0	B,s1-d0	B,s1-d0	B,s1-d0
Reaction to fire performance EN 13501 - 1** With SAFE and SAFE+ backing film installed, Silicone adhesive	B,s1-d0	B,s1-d0	B,s1-d0	n/a

* Restrictions apply: See colour charts

** Specific circumstances apply. The product is fixed onto the substrate using AGC FIX-IN adhesives in the amounts as described in their respective technical data sheets

*** Incl Matelac Silver Clearvision, Grey & Bronze

**** Specific colours are classified B,s1-d0. Specific colours for SAFE: Starlight Black (ref 0337), Rich Yellow (ref 1023), Pearl White (ref 1013), Luminous Red (ref 1586) and Rich Aluminium (ref 9007). Specific colours for SAFE+: Starlight Black (ref 0337) and Rich Yellow (ref 1023)

***** Specific colours are classified A2,s1-d0: - 4 mm: Pure White (ref 9003), Classic Orange (ref 2001), Fuchsia (ref 4006), Soft White (ref 9010), Pearl White (ref 1013), Luminous Red (ref 1586), Classic Beige (ref 1014). 4, 5, 6 mm: Starlight Black (ref 0337). 4, 5, 6, 8 mm: Rich Yellow (ref 1023)

The painted side is glued on any substrate with a fire performance A2,s1-d0 or better with a density at least 525 kg/m³ and a thickness at least 12 mm. All fire classification results mentioned in this table are based on a glass thickness of 4mm, 5mm and 6 mm.

1.9 ADDITIONAL TREATMENT - AntiBacterial™ GLASS

AntiBacterial™ (AB™) GLASS

The process developed and patented by AGC Glass Europe involves diffusing silver ions in the upper layers of the glass. The ions interact with and destroy bacteria by disrupting their ability to divide. The antibacterial effect of the glass is continuous, particularly in the warm and moist conditions that encourage the growth of bacteria and mould.

AntiBacterial™ glass by AGC Glass Europe is a major innovation in the world of glass design.

The antimicrobial action of the silver ions inside the glass eliminates 99.9% of all bacteria that form on its surface whilst also preventing the spread of fungi. This remarkable property makes it perfect for locations with strict hygiene requirements.

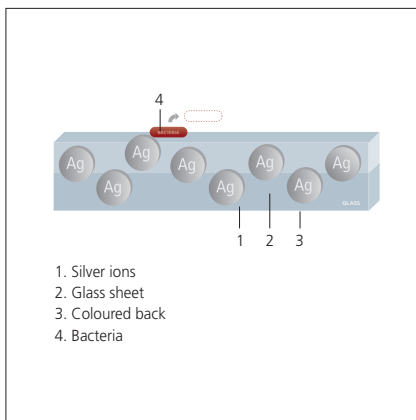

AntiBacterial™ GLASS

AntiBacterial™ GLASS: INTERIOR APPLICATIONS

Lacobel AB™ or Mirox AB™ are ideal for wall covering in places that are:

- subject to specific hygiene requirements:
 - haematology, oncology and geriatric units, isolation rooms, burn units, sterilisation rooms, etc.
 - clinics, hospitals, maternity units
 - pharmacies and laboratories
 - rest homes
- damp and thus prone to bacterial and fungal development:
 - showers and bathrooms
 - health spas
 - sports halls, etc.
- open to the public:
 - canteens, toilets, etc.
 - waiting rooms, etc.
 - fitness centres, beauty salon, etc.

Planibel AB™ can be laminated and fitted as partitioning or double glazing.

AntiBacterial™ GLASS: PERFORMANCE

The performance of AntiBacterial™ glass has been tested on a representative range of bacteria and fungi:

- 1. Bacteria**
 - Staphylococcus aureus
 - Escherichia coli
 - Pseudomonas aeruginosa
- 2. Fungi**
 - Aspergillus niger
 - Candida albicans

The results showed a drastic reduction in initial bacterial concentrations as well as a cessation of fungal growth. Though present in low concentrations, the silver ions give the glass its bactericidal and fungicidal effects.

Products:

- Lacobel AB™
- Mirox AB™
- Planibel AB™ (see www.yourglass.com for further information)

All products are also available with a SAFE and SAFE+ backing film.



AntiBacterial™ LOGO

AntiBacterial™ GLASS: COMPLIANCE

The testing procedure for AntiBacterial™ glass is based mainly on European standard EN 13697, with additional components derived from JIS Z 2801, EN 1276 and EN 1650.

Test reports are available on request.

AntiBacterial™ GLASS: PROCESSING

Only one side of the glass can have AntiBacterial™ properties.

AB™ glass cannot be heated above 150°C, so it cannot be tempered. AB™ glass cannot be acid-etched.

The AB™ properties are located on the surface of the glass, which retains these properties over time.

The edges of the sheet and drill holes (if any) do not have AB™ properties.

Installation techniques differ depending on the product chosen.



LACOBEL ANTIBACTERIAL™ GLASS

1.10 ADDITIONAL TREATMENT - SAFE AND SAFE+ BACKING FILM

SAFE AND SAFE+ BACKING FILM: APPLICATION

To prevent the glass from breaking into shards under impact, a SAFE and SAFE+ backing film can be applied industrially to the back of the glass. Glass with a SAFE and SAFE+ backing film can be installed using:

- silicone adhesive,
- mechanical fitting techniques.

It is designed for interior use only.

If Lacobel, Matelac and Mirox are fitted with a SAFE and SAFE+ backing film, they can also be used in applications having more extensive safety requirements. Products with a safety backing film can only be bonded with silicone after being pre-treated with the surface activator.

Exterior: The product is not designed for use in exterior applications.

SAFE AND SAFE+ BACKING FILM: PRODUCTION

The SAFE and SAFE+ backing film (3) is applied to the back of the glass (1) sheet (painted side, 2) under special conditions in the factory.

SAFE or SAFE+ safety backed glass is complying to EN 12600 class B.

AGC's controlled industrial process guarantees this safety standard for your project.

The film also protects the paint on the back of the glass from being scratched during handling and installation.

The SAFE and SAFE+ backing film is available for the following products:

- Lacobel
- Matelac
- Mirox



FIXATION

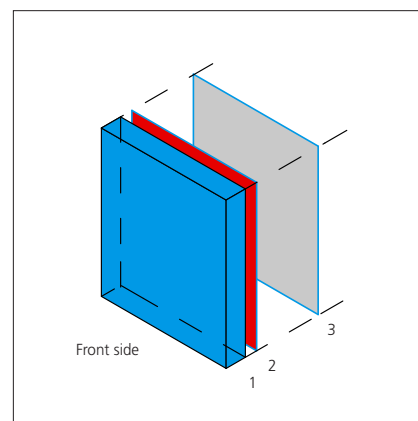

SAFE AND SAFE+ BACKING FILM

SAFE and SAFE+ backing film: Availability

	Dimensions in cm	Thickness of glass sheet in mm	Other dimensions	Installation	Product
Lacobel, Matelac, Mirox with SAFE and SAFE+ backing film	Max. 255 x 321	Max. 10	-	Only silicone Pre-treated with FIX-IN SA surface activator	FIX-IN SL

FOR MORE INFORMATION, SEE PAGE 18

2.1 SAFETY - TESTS AND REGULATIONS

SOFT BODY IMPACT TEST (EN 12600)

The impact test has been designed to simulate a person hitting the installed glass sheet. The cushioned impactor is swung against the vertical glass, starting from different heights. The result denotes the level of safety, even if the glass breaks.

If glass fitted with the AGC SAFE and SAFE+ backing film is broken, the fragments stick to the film, reducing the risk of injury or falling through the glass.

Test results are represented by a three letter code: For example: 2B2.

This means the pendulum hits the glass from a height of 450 mm and the glass breaks safely (or not at all) according to the definition set out in the standard.

IMPACT TEST RESULTS

Lacobel, Matelac and Mirox, safety backed with SAFE or SAFE+ film, are complying to EN 12600 class B.



SOFT BODY IMPACT TEST

2.2 FIRE PERFORMANCE

The European fire classification system is detailed in BS EN 13501-1.

A product's classification as a result of its response to a fire test is included in a classification report. The report details the fire class, gives a full product description and also provides a range of applications describing (and potentially limiting) how the product may be used.

A product's potential contribution to a fire depends not only on its intrinsic properties and the thermal attack, but also to a large extent on how it is used in the final construction. Therefore the product should be tested in a way that simulates its end use. As a result, a given product might have different classifications for different end uses, determined mainly by aspects such as how the product is oriented and how it is fixed to a substrate (wall).

For Lacobel and mirrors, the following tests are important in determining the final classification.

CALORIFIC POTENTIAL TEST (EN ISO 1716)

This test determines the potential heat release by a product when complete combustion occurs, regardless of its end use (relevant for classes A1, A2).

SINGLE BURNING ITEM TEST (EN13823)

This test evaluates the potential contribution of a product to the development of a fire in terms of heat and smoke release and burning droplets, under a fire situation simulating a single burning item in the corner of a room near to the product (relevant for classes A2, B, C & D). It provides data suitable for comparing the performance of materials exposed on surfaces (such as walls).

IGNITABILITY (EN ISO 11925-2)

This test evaluates the ignitability of a product in a vertical orientation when exposed to a small flame on the

surface and, where appropriate, the edge (relevant for classes B, C, D, E).

Lacobel and mirrors with or without SAFE and SAFE+ backing film, are classified by a notified body according to EN13501-1 and are evaluated both in freestanding and mounted mode so as to simulate their end use.

Lacobel and mirrors are mounted with the FIX-IN system (silicone glue) onto plasterboard (density 700kg/m³, thickness 12.5mm) to cover the broadest range of end uses.

Test results are represented by a code, for example "A2,s1-d0".

A2 indicates the fire growth rate (FIGRA), Lateral Flame Spread (LFS) and Total Heat Release (THR).

s1 indicates the Smoke Growth Rate (SMOGRA) and Total Smoke Production (TSP).

d0 indicates the flaming droplets/particles.

3.1 SUBSTRATES AND SUBSTRUCTURES

SUBSTRATES

Many different materials can be used as substrates for the glass.

Substrates must be strong enough to support the weight of the glass (2.5 kg/m²/mm) without any risk of warping, bending or deformation of any kind.

Substrates must also be even and flat enough to prevent any visible curving of the glass.

If the substrate is porous, it must first be treated with a primer. AGC offers a substrate primer for the silicone bonding system (see the table below: Substrates and primers).

To ensure a solid bond between the glass and substrate, all components must be thoroughly cleaned and dried. They must also be free of any dust, particles, oil, wax, dirt or other impurities likely to reduce adhesion.

There are various reasons why such impurities might be present: grinding work, shuttering oil (formwork oil), grease-protected metal surfaces or even dirty fingers.

Concrete must be sufficiently dry (usually after 3 months) before it can be used as a substrate for glass.

SUBSTRATE COLOUR

By using transparent joint fillers, the wall surface colour can be visible through the joints. To ensure uniform joints, AGC recommends painting the entire wall (or at least the areas behind the glass joints) in a colour similar to the glass colour.

For some light colours (colours marked with S-W in colour charts) AGC recommends to ensure a uniform white painted background for a uniform appearance of the glass installation. In this case, no extra wall primer is needed on the porous surface, as the paint then functions as primer. If coloured strips (painted) behind the joints are desired, always place the tape on the white areas besides these strips.

FLATNESS OF THE WALL

Measuring the flatness and evenness of a wall (finished surface):

Use a straightedge against the wall (1) to gauge how smooth it is and to see if there are any peaks. The maximum height of peaks is limited with respect to the distance between peaks.



MEASUREMENT OF FLATNESS OF THE WALL

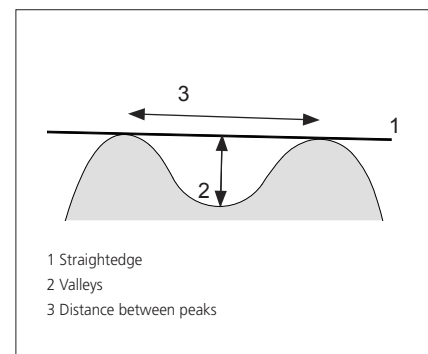

MEASUREMENTS OF FLATNESS

Requirements for walls, flatness	Distance between peaks (3)	Maximum depth of valley (2)
Wall surface, finished	1 m	3 mm
Wall surface, finished	4 m	8 mm
Wall surface, finished	10 m	15 mm

3. PREPARATION AND FINISHING

EXPANSION JOINTS

All expansion joints and sliding joints in the building must be respected. If there is an expansion joint behind the glass installation, the glass structure also needs a joint at the same place and having the same properties (dimension of contraction and expansion).

For substructures please see instructions issued by the substructure manufacturers.

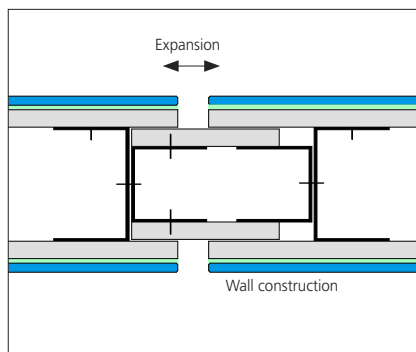

EXPANSION JOINT: WALL

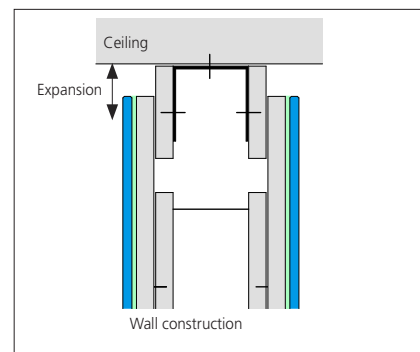

SLIDING JOINT: CEILING

Substrates and primers

Product	Silicone	
	FIX-IN PR Primer	FIX-IN SL Silicone adhesive
MDF, Medium Density Fibreboard (EN 316)	No	Yes
OSB, Oriented Strand Board (EN 300)	No	Yes
Particle board, not fire retardant treated (EN 312)	No	Yes
Gypsum plasterboard (EN 520)	Yes	Yes
Plywood, not fire retardant treated (EN 636)	No	Yes
Calcium silicate board (prEN 14306)	Yes	Yes
Fibre cement board (ISO 390)	Yes	Yes
Gypsum plaster	Yes	Yes
Cement plaster	Yes	Yes
Concrete	Yes	Yes
Brick masonry	Yes	Yes
Tiles, existing	Not needed if clean and adherent (see § 6.6)	Yes

3.2 EDGE FINISHING

EDGE FINISHING

When glass is cut, the edges are sharp, rough and likely to cause injury. It is nearly impossible to ensure a nice joint between installed sheets if the edges have not been processed.

Different processed edge options are available, including straight, rounded and bevelled.

There are almost no restrictions on edge processing.

The edge shape influences the appearance of the installed glass.

Firstly, the edge is visible from the far corners of the room.

Secondly, the edges determine the appearance of the joints between the sheets. Wide joints emphasise the pattern of the sheets, while narrow joints emphasise the two-dimensional appearance of the glass wall.

Note:

When using FIX-IN SL silicone, AGC recommends minimal edge bevelling and processing (1-1.5 mm) to avoid an enlargement of the visible joint width.

ARRISSED EDGE

The edge is slightly sanded after cutting, i.e. left virtually untreated.

Application: Only if the edge is not visible, for example for use in frames.

Arrissed edge.

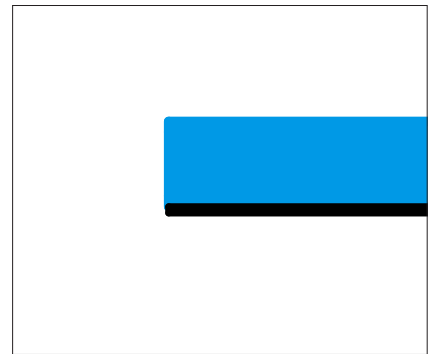

ARRISSED EDGE

U-SHAPE

The edge is ground on both sides of the glass sheet.

Application: Wall cladding, furniture, etc.

U-shaped edge.

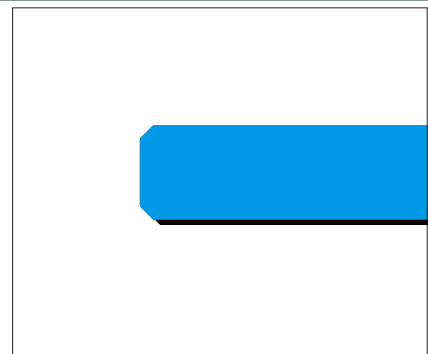

U-SHAPED EDGE

C-SHAPE

Rounded edge, where the diameter is the thickness of the glass sheet.

Application: visible edge, furniture, etc.

C-shaped edge.

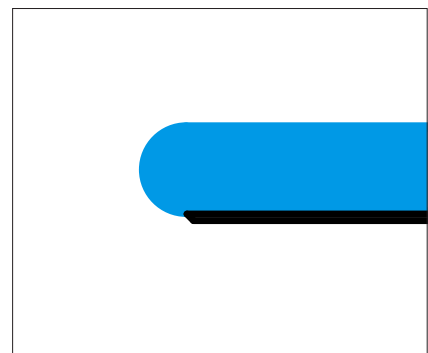

C-SHAPED EDGE

BEVELLED EDGE

The edge is clearly bevelled.

Application: wall cladding, furniture, etc (mostly mirror).

Bevelled edge.

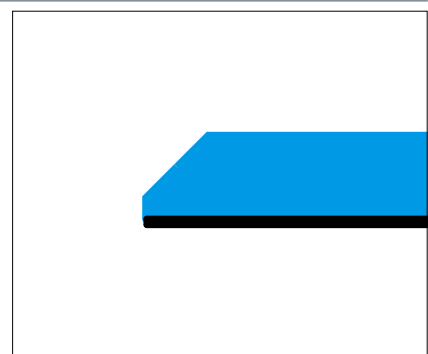

BEVELLED EDGE

3.3 CORNERS

CORNERS

AGC Lacobel, Lacobel T, Matelac, Matelac T and Mirox consist of a sheet of clear float glass with a coloured coating on the back.

The edges of the sheets are not coated and cannot be coated afterwards.

Consequently, special attention must be paid to edge design.

Specifically, the far corners of a room or object play a critical role in the appearance of the glass structure.

Two factors must be taken into account: design and durability.

Edges can be formed by the two sheets of glass alone (see glass corner) or by using additional profiles (usually made of metal).

Note:

If the glass edge is significantly bevelled, then shadows or reflections can occur in corner and joint areas.

CORNERS: GLASS SOLUTION

The shape of the glass edge of the sheet determines the appearance of the corner.

Even though the glass is resistant to impact when installed on the wall, the corners are more fragile and easily subject to damage caused by impact.

CORNER: PROFILE SOLUTION

Metal profiles can be used to protect the open edges of glass sheets, thus providing better protection in areas where there is a risk of impact. Tile profiles can be used if they have the right thickness for the glass.

Note:

AGC recommends to always use a corner profile to improve the resistance of the glass when installed.

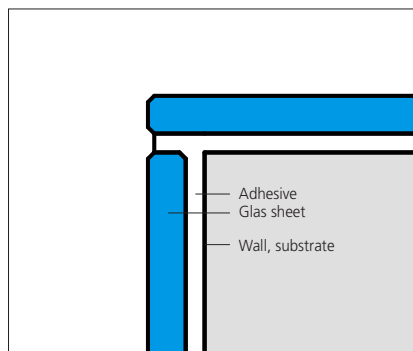

GLASS CORNER: GLASS JOINT

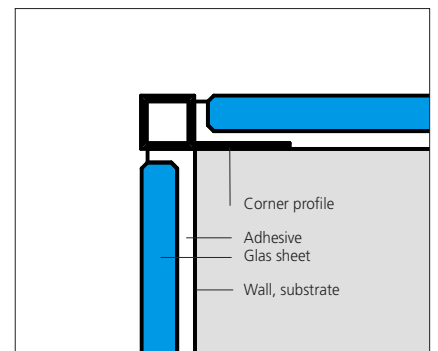

CORNER PROFILE: SQUARE

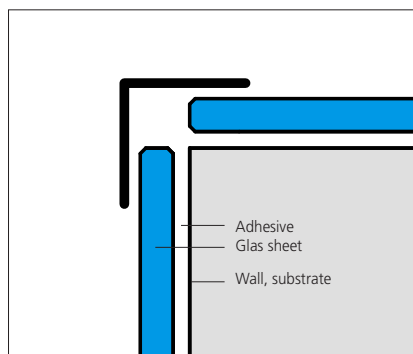

CORNER PROFILES: ANGLE SHAPE

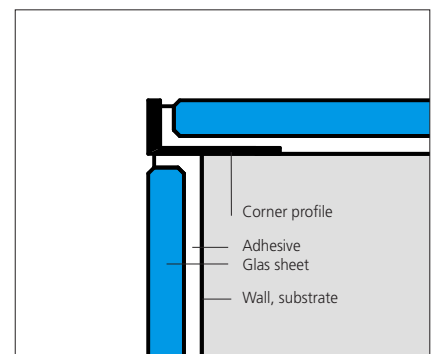

CORNER PROFILES: L- SHAPE

3.4 CUTTING AND DRILLING

PROCESSING THE GLASS

There is an essential difference between additional processing for non-tempered products (such as Lacobel, Matelac and Mirox) and tempered products (Lacobel T / Matelac T).

Float glass products (Lacobel, Matelac and Mirox) can be cut and drilled later on, even on the construction site.

However, Lacobel T / Matelac T must be cut, drilled and edge finished prior to the tempering process. After tempering, no additional processing is possible.

The large production sheets (measuring up to 6 m x 3.21 m) give designers plenty of scope to choose the format they want.

Full sheets can be cut in such a way as to ensure economical use and minimal waste.

Efficient edge processing ensures consistent quality of the sheets supplied.

The size of sheets used in projects is generally not determined by the production size, but by the technical restrictions encountered in handling and transporting the glass to and into the building.

Staircases, elevators and doors ultimately determine how big the glass sheets can be.

CUTTING AND DRILLING IN THE FACTORY

After production of standard sheets in the factory, the glass is processed in a dedicated plant that specialises in cutting sheets to size, edge processing and drilling.

Lacobel T / Matelac T must always be processed prior to the tempering process.

CUTTING AND DRILLING ON SITE

Only float glass products such as Lacobel, Matelac and Mirox can be processed later. Cutting, drilling, edge finishing and other processing options are possible, but due to variations in finish, AGC advises clients not to do this work manually. Only industrially processed glass sheets can guarantee the desired high quality.

CUTTING AND DRILLING LACOBEL T / MATELAC T

Lacobel T / Matelac T cannot be processed after tempering.

4.1 INSTALLATION SYSTEMS

BONDING: INTRODUCTION

Gluing is the most common method for bonding glass sheets onto a substrate (such as walls, furniture and other structures).

AGC has many years of successful experience in this field and provides its own advanced solution for the many different bonding and fitting options available.

Bonding systems are invisible. Unlike many visible fitting methods (using screws, rivets, etc.), bonding systems ensure that there is no visible means of fixation to interrupt the smooth appearance of the flat glass wall.

AGC offers a solution for interior applications which includes the bonding adhesive and the appropriate primer and surface activator. Professionals can buy the components online at www.agc-store.com or from their glass processors.

All the system components have been standardised to ensure that the glass

adheres properly to the substrate. For good results it is necessary to respect the product expiration dates and storage conditions (see Technical Data Sheets (TDS) and Material Safety Data Sheets (MSDS)).

Make sure to comply with local regulations when using the AGC FIX-IN System.

FIX-IN SL: SILICONE BONDING

Silicone is the most commonly used bonding method. The glass can be bonded onto a wide variety of substrates. Some substrates and glass products will require pre-treatment with primers or surface activators.

Tested and approved

AGC products:

- **FIX-IN PR** wall primer
- **FIX-IN SA** surface activator (SAFE and SAFE+ backing film)
- **FIX-IN AT** adhesive tape (as a spacer and for initial tack)
- **FIX-IN SL** silicone



SILICONE FIX-IN SL

Bonding systems and materials

Product	Material	Adhesive	Wall primer	Surface activator	Product
Lacobel, Matelac, Mirox	Float glass with painted back	Silicone*	FIX-IN PR	No	FIX-IN SL
Lacobel, Matelac, Mirox with SAFE and SAFE+ backing film	Float glass with painted back and SAFE and SAFE+ backing film	Silicone*	FIX-IN PR	FIX-IN SA	FIX-IN SL
Lacobel T / Matelac T	Tempered glass with enamelled paint on back	Silicone*	FIX-IN PR	No	FIX-IN SL

* Restrictions apply: See colour charts



INVISIBLE FITTING: SHOPPING MALL

4.2 FITTING SYSTEMS

INSTALLATION SEQUENCE

Even if the dimensions are taken from the existing wall and applied exactly to the glass, tolerances must be included in the building and in the glass sheets.

To deal with these tolerances AGC recommends that installation be started at the outer edge of the room. This is the most exposed and visible part of the glass installation and must be precise.

Tolerances can be taken into account much better in the inner edge of the room.

ADHESIVE TAPE AND CURING TIME

Silicone adhesive:

When using FIX-IN SL silicone in combination with adhesive tape for initial tack (and to maintain the gap between the wall and the glass), the glass sheets will stick to the wall immediately.

To position the glass correctly, a spacer (synthetic 90 shore) of the appropriate thickness can be positioned under the lower edge of the glass.

When using adhesive tape only to maintain the necessary gap between the glass and the substrate, the glass sheets must be supported until the silicone cures.

FIX-IN SL silicone:

Curing time

- 48 hours (minimum curing time) after installation, the support can be removed (initial strength).
- 48 hours after installation, joints can be sealed.
- Final strength: after 1 week.

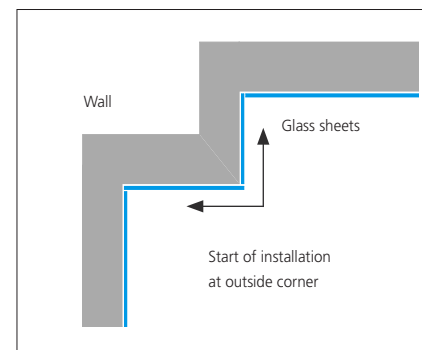

SEQUENCE OF MOUNTING: FLOOR PLAN

Silicone bonding: amount of FIX-IN products required

Material	Product	Installation	Amount needed
Silicone adhesive	FIX-IN SL	Cartridge 310 ml, V-shaped nozzle	Depending on glass thickness: 6 mm: approx. 400 ml/m ² 10 mm: approx. 550 ml/m ²
Adhesive tape	FIX-IN AT	Self-adhesive	Depending on glass thickness: 4 mm: 2 m/m ² 6 mm: 3 m/m ² 8-10 mm: 4 m/m ²
Wall primer (for silicone and adhesive tape)	FIX-IN PR	Brush, roller	Depending on porosity of surface: approx. 100-200 ml/m ²
Surface activator (for SAFE and SAFE+ backing film)	FIX-IN SA	Aerosol (spray)	approx. 2,5 ml/m ²

5.1 FIX-IN SL SILICONE

THE FIX-IN SL SYSTEM

The most common way of installing glass sheets is to bond them to the substrate using silicone-based products.

The FIX-IN system ensures good compatibility between the different components, thus preventing damage to the paint from corrosive components in the glue.

The FIX-IN system is ideal for Lacobel, Matelac and Mirox, with or without the additional SAFE and SAFE+ backing film. It is also suitable for Lacobel T / Matelac T (indoor use only!), which are always produced without the safety backing film.

The FIX-IN system is designed for use in moist and dry areas, but for interior applications only.

As the silicone cures, it may be visible from the front of the glass sheet. However, once it is fully cured, the silicone is no longer visible.

For Crisp White in the Lacobel T / Matelac T range, AGC recommends not using silicone due to the formation of permanently visible spots.

Note:

Local standards and regulations must be respected when planning projects and installing glass sheets.

Important:

FIX-IN SL needs to be stored (between 5°C and 25°C) and handled in accordance with the Technical Data Sheet (TDS), the installation guide and Material Safety Data Sheets (MSDS) available on www.yourglass.com or from your local AGC contact.

FIX-IN SL SILICONE

AGC's transparent FIX-IN SL silicone is ideal for forming a strong bond between silvered/painted glass and a substrate.

Silicone FIX-IN SL must be combined with FIX-IN AT adhesive tape. This ensures the right amount of glue is used and the proper ventilation is achieved.



SILICONE CARTRIDGE & ADHESIVE TAPE

FIX-IN PR SUBSTRATE PRIMER

If the substrate is porous, it must first be treated with a primer.

The primer prepares the surface of the substrate so that it can provide a good surface onto which the glass can be bonded.



PRIMER

FIX-IN SA SURFACE ACTIVATOR

For all products with a SAFE and SAFE+ backing film, a surface activator must be applied to the safety backing film prior to using FIX-IN SL silicone and FIX-IN AT adhesive tape.



SURFACE ACTIVATOR

JOINT SEALING (NOT FOR MIROX)

In moist areas the joints between the sheets themselves and between the sheets and adjacent elements (such as taps and door/window frames) must always be sealed with FIX-IN SL silicone. This ensures that the walls are fully covered. When done properly, no water or moisture can affect the wall system or the painted side of the glass.

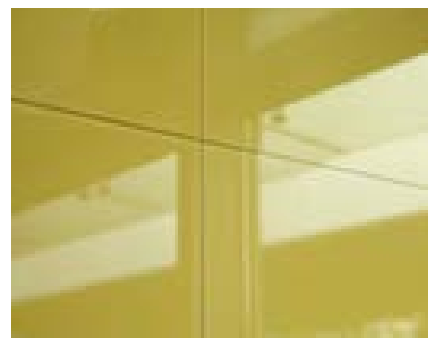

JOINTS WITH SILICONE



LACOBEL

USE OF FIX-IN SL

AGC's FIX-IN SL silicone adhesive is always applied in vertical lines onto the wall surface. If the surface is flat and straight, the glue may also be applied to the back of the glass sheets.

In addition the double-sided adhesive tape must always be applied parallel to the silicone lines.

This ensures ventilation while the silicone cures and is also providing the permanent ventilation mirrors need to prevent condensation from forming on the back of the glass.

A roller must be used to press the tape against the substrate (before removing the release liner) to ensure good adhesion.

The tape also provides initial tack until the silicone bond has reached full strength.

The table below shows the minimum recommended glue lines for the AGC FIX-IN system.

The number of glue lines depends on the thickness (weight: 2.5 kg/mm/m²) of the glass.

The correct quantity of glue is ensured by using a V-shaped nozzle (supplied with the AGC FIX-IN SL cartridge).

See the table at the beginning of the chapter to calculate how much FIX-IN SL needs to be used.

Glass sheets must be fitted immediately after applying the FIX-IN SL silicone, and before a skin develops on the adhesive (within 15 minutes).

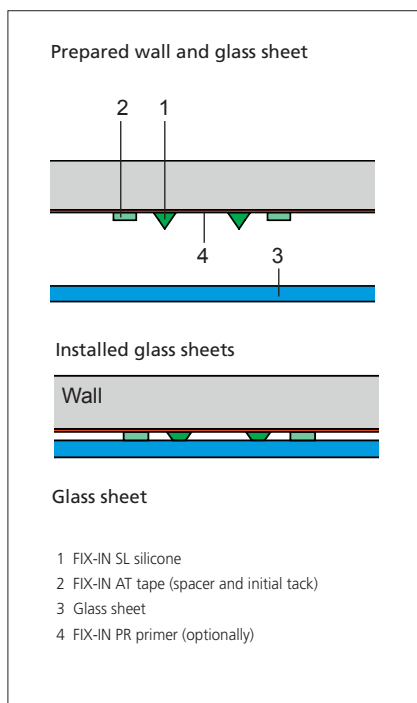

GLASS WITHOUT SAFETY BACKING FILM

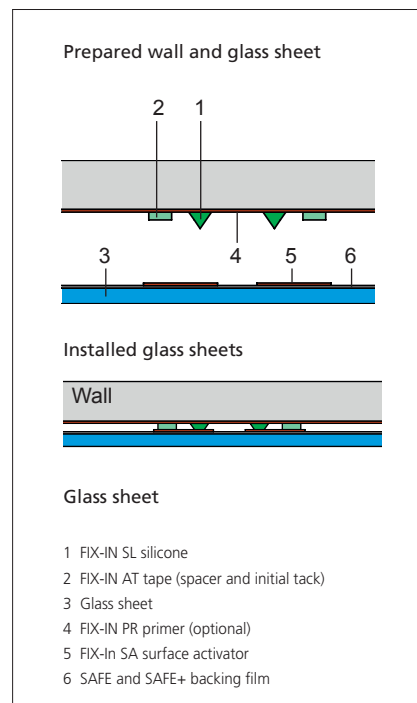

GLASS WITH SAFE AND SAFE+ BACKING FILM

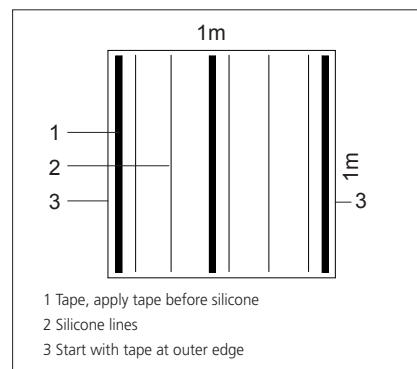

APPLICATION OF ADHESIVES

Material	Product	Glass thickness	Minimum running m per m ²
Silicone adhesive	FIX-IN SL	4 mm	4
		6 mm	5
		8 mm	6
		10 mm	7
Adhesive tape (in addition to silicone adhesive)	FIX-IN AT	4 mm	2
		6 mm	3
		8-10 mm	4

FIX-IN SA SURFACE ACTIVATOR

Lacobel, Matelac and Mirox with a SAFE and SAFE+ backing film require a surface activator to be applied to the back of the glass sheet (film) when using FIX-IN SL silicone and FIX-IN AT adhesive tape.

The FIX-IN SA surface activator is used to clean and degrease non-porous substrates and the SAFE and SAFE+ backing film.

It also prepares the surface of the film to ensure the correct adhesion to FIX-IN SL and FIX-IN AT. The surface activator (aerosol) is sprayed onto the SAFE and SAFE+ backing film on the back of the glass sheet where the silicone is applied.

Wipe off the sprayed surface with a clean cloth using the “wipe on, wipe off” method. This means that only one movement in one direction is used. Replace the cloth after every meter, or earlier if the cloth becomes highly soiled. Ensure the room is well ventilated during application.

Products without a safety backing film do not need a surface activator on the back of the glass.

After the surface activator has dried for at least 5 minutes (and up to 8 hours), FIX-IN SL silicone and FIX-IN AT adhesive tape can be applied to the treated areas.

See the Technical Data Sheet (TDS) and Material Safety Data Sheet (MSDS) available on www.yourglass.com or from your local AGC contact for more info.

FIX-IN PR WALL PRIMER

All porous surfaces (plaster, gypsum board, etc.) must be treated with a primer prior to installing the glass sheets. See chapter 3.1 for details.

The transparent FIX-IN PR primer should be applied with a brush or roller to the surface to which the glass will be bonded.

Curing time: at least 30 minutes, up to 4 hours.

Humidity: 45-65 RH

Temperature: 15 - 25° C.

See the Technical Data Sheet (TDS) and Material Safety Data Sheet (MSDS) available on www.yourglass.com or from your local AGC contact for more info.

SILICONE BONDING: RESTRICTIONS

Some colours (indicated in the colour charts of Lacobel, Matelac and Mirox) must be protected from moisture and water by a SAFE and SAFE+ backing film.

In this case the film functions as additional protection for the painted side of the glass.

The additional backing also results in a higher safety rating and protects the back from damage during handling and installation.

JOINTS

Joints should be sealed to prevent dirt and dust entering the cavity behind the glass.

However, in dry areas the joints can be left open if desired.

For Mirox, ventilation must be ensured by leaving the joints unsealed, whether in dry or humid environments.

AGC's FIX-IN SL silicone (transparent) can also be used to fill the joints.

The joints can be sealed once the FIX-IN SL silicone used for bonding has fully cured (48 hours).

For finishing the joints, use water and detergent before a skin develops (within approximately 15 minutes).

Tools can be cleaned with white spirit, if necessary.

JOINT DIMENSION

The recommended width of the joints will vary depending on the thickness of the glass.

The structural condition of the substrate must also be taken into consideration.

For example: 6 mm glass requires a 3 mm joint.

COLOURED JOINTS

If the substrate is painted prior to installing the glass sheets, the substrate colour will be visible through the transparently sealed joints.

AGC recommends installing a mock-up to check results prior to installation, because the various factors, such as the light, sealant (even if transparent) and the geometry and width of the joint can have an impact on the final result.

MASKING THE JOINTS

Apply masking tape to the glass surface around the edges of the sheets prior to sealing the joints in order to avoid staining the glass.

First check that the tape and glass are compatible.

The surface of Matelac and Matelac T in particular must be protected from contamination by silicone and other sticky substances. The rough acid-etched surface is difficult to clean again afterwards.

CUT-OUTS: INSTALLATION

To improve the bond between glass and substrate near cut-outs, additional silicone must be applied around the holes prior to installing the glass.

After installing the glass, the gap between the glass and wall must be sealed. The silicone must be pressed into the cavity by applying slow, firm pressure.

JOINT MAINTENANCE

AGC recommends inspecting the joints within at least 2 years. Remove and repair any damaged parts of the sealant.

MATELAC AND MATELAC T: SURFACE PROTECTION

Extra care must be taken to keep the glass clean when using silicone adhesive to bond Matelac or Matelac T to the substrate.

The acid-etched surface of Matelac and Matelac T is rough and very sensitive to contamination from the adhesive used for installing the glass and filling joints.

To protect the sensitive surface of the glass near the edges, AGC recommends applying masking tape before installing the glass sheets.

Once the surface becomes soiled, it cannot be cleaned without leaving some residue.

FITTING - SLEEVES

Substrate requirements:

The substrate and wall construction must be sufficiently strong and impact-resistant to support and hold the fitting mechanism without bending, warping or otherwise deforming.

Unless tempered glass is used, care should be taken to avoid putting pressure on the installed glass.

During the fitting process, pressure can be avoided by applying a sleeve or tube (or other spacers) to the fitting mechanism (mainly threaded rods and screws).

This method is mandatory for all installations.

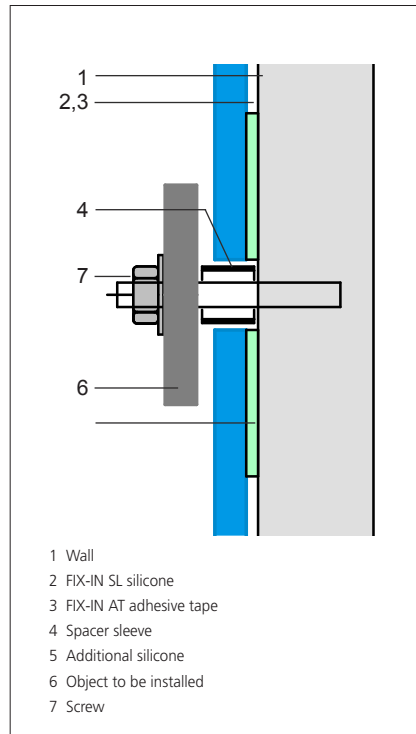

INSTALLATION USING SLEEVES



FIX-IN SL SILICONE JOINTS

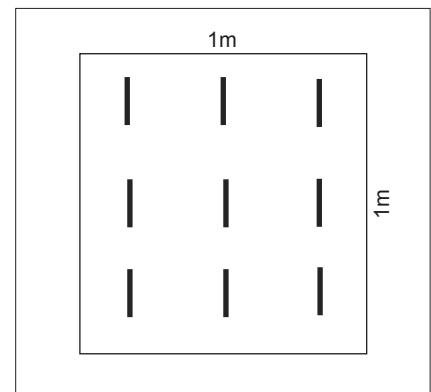

MINIMUM AMOUNT OF TAPE WHEN USED AS SPACER

TAPE AS A SPACER

FIX-IN AT can also function as a spacer only to maintain the distance (3.2 mm) between the back of the glass and the substrate. Used this way, the tape ensures a proper curing and ventilation purpose.

In this case the amount of tape can be reduced to 9 strips (each one of which is 10 cm long) per m² glass.

Since a small amount of tape is used, the glass must be supported to ensure it is held in the right position while the adhesive cures for at least 48 hours.

The number of silicon lines is the same as for the use of the tape as initial tack.

5.2 FIX-IN SL SILICONE FOR MIROX

MIROX

AGC's Mirox range of mirrors can withstand normal humid environments, such as properly ventilated bathrooms and kitchens.

Care must be taken to prevent water from coming into contact with the painted side or edges of the glass. When cleaning the mirror, the edges must be dried quickly and thoroughly.

MIROX: VENTILATION

The painted side of the mirror must always be ventilated. Ventilation removes condensation, keeping the mirror dry on the back. That is why the bottom and top edges of the installed mirror must remain open (4).

To ensure a correct gap between the glass and the wall, the same installation guidelines must be followed as for Lacobel, Matelac, Lacobel T / Matelac T (see previous chapters).

Like other glass products, mirrors must be supported while the silicone cures.

MIROX: MECHANICAL FITTING

If any kind of profiles or mechanical fitting mechanisms are used, care must be taken to ensure that the system drains properly.

The mirror must never be immersed in or stand in water.

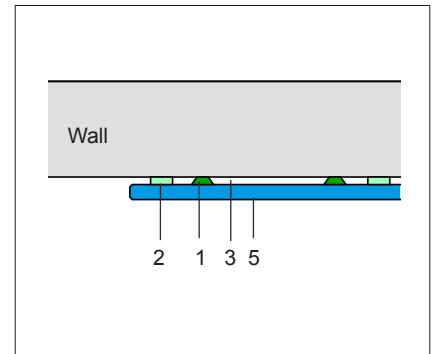

HORIZONTAL SECTION

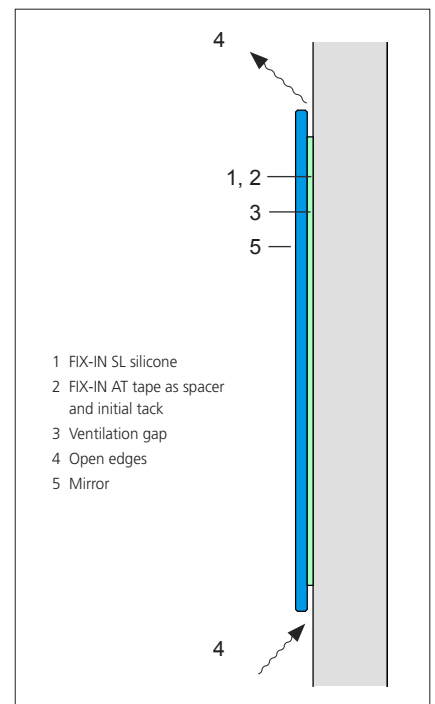

VERTICAL SECTION



MIROX

6.1 FIX-IN SL SILICONE FOR FURNITURE

FURNITURE

AGC glass products are perfect for furniture applications, with the colours and surfaces of Lacobel, Matelac, Mirox, Lacobel T and Matelac T, providing designers with a host of options. While it is ideal for use on flat, untreated surfaces, glass can be combined with many other materials found in contemporary furniture.

AGC has tested the adhesion of glass to a variety of substrates and proven the feasibility of these combinations.

The tested substrates can be found in Chapter 3 of this manual.

Glass can also be used for doors, but care must be taken to factor in the weight and additional thickness of the glass when specifying hinges and other accessories.

An interlayer (such as wood fibre or aluminium honeycomb panels) can be used if doors need to have the same surface on the front and back. A metal frame covers and protects the edges.



LACOBEL FOR FURNITURE

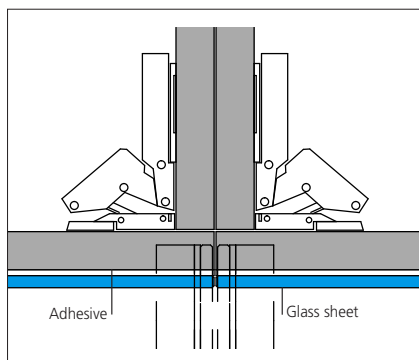

FURNITURE: DOORS

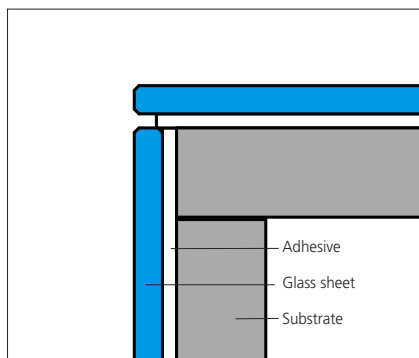

FURNITURE: DOOR AND CORNER

A SAFE and SAFE+ backing film should be used for this application, depending on safety requirements.

The rear side of the glass is characterised by the paint or SAFE and SAFE+ backing film applied to the glass.

In either case, the back is not meant to be visible.

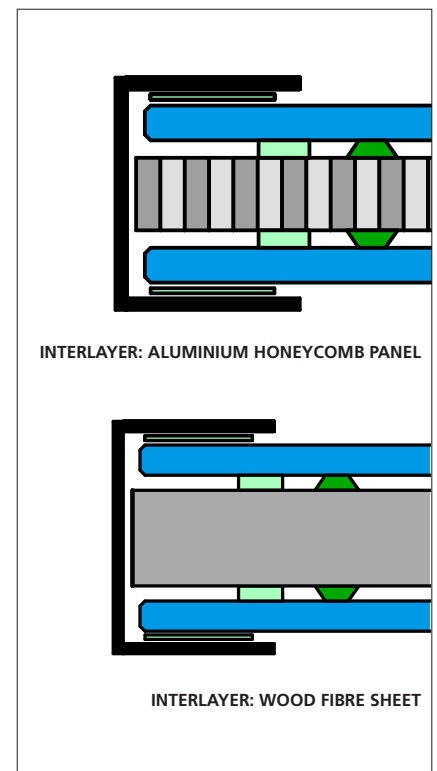

DOOR STRUCTURES



LACOBEL FOR FURNITURE

6.2 FIX-IN SL SILICONE FOR HUMID AREAS

WET AND HUMID AREAS

Bathrooms and showers are subject to heavy use.

In such applications, it is critically important to use strong, watertight materials in order to ensure a long service life.

The materials used should also be easy to clean and maintain.

Glass is the perfect solution for these requirements.

Lacobel, Lacobel T and Mirox are supplied in large sheets that can be cut to any size, even up to the height of one full storey. By using large panels, the number of joints and their length can be minimised, making the final result appear nearly seamless.

The hard, uniform surface is not only capable of withstanding a multitude of environmental stresses, but it is also easy to clean.

If enhanced hygiene is required, then the AntiBacterial™ version of Lacobel and Mirox is the perfect choice.

Note: Local standards and regulations must be respected when planning projects and installing glass sheets.

MOISTURE PROTECTION

Care must be taken to prevent water from penetrating behind the glass. Some colours (indicated in the colour charts of Lacobel and Matelac) also require a SAFE and SAFE+ backing film to prevent water and moisture from coming into contact with the painted side of the glass.

The SAFE and SAFE+ backing film also results in a higher safety rating and protects the painted side during handling and installation.



LACOBEL T

6.3 FIX-IN SL SILICONE FOR SPLASHBACKS

SPLASHBACKS

Splashbacks are heavily used areas that are typically subject to plenty of dirt, oil and detergents, along with heat and other corrosive conditions.

Different types of glass are designed to resist all such corrosive elements, maintaining their excellent performance for many years after installation.

LACOBEL T / MATELAC T: HEAT-RESISTANT GLASS

Lacobel T / Matelac T combine long life with improved resistance to thermal shocks caused by gas stoves, hot kitchen equipment.

Not only do they offer enhanced heat resistance, they are also stronger.

Lacobel T / Matelac T can be installed behind hobs and stoves without any additional protection.

LACOBEL

Lacobel is supplied in large sheets that can be cut to any size. By using large panels, the number of joints and their length can be minimised, making the final result appear nearly seamless.

With its hard, uniform surface, Lacobel is the ideal choice for such applications.

Standard and custom colours are available, so that the glasses can fit into any kitchen design concept.

Care must be taken to avoid a situation where the glass sheet is heated (by flames or other heat sources) in a localised area (creating a temperature difference of more than 30° C within the sheet).

Options are to use the same material as the work surface (if suitable for this purpose) as plinth material combined with Lacobel or Matelac above it, or to use Lacobel T / Matelac T.



LACOBEL T



LACOBEL T: HEAT-RESISTANT



LACOBEL T FOR SPLASHBACK

6.4 FIX-IN SL SILICONE FOR ELEVATORS

ELEVATORS: CARS AND SHAFTS

Glass can accentuate elevator shafts and emphasise the feeling of verticality in the building. It is the perfect choice for use inside elevator cars.

Because of its hard, uniform surface, glass is the ideal material for elevators. Glass sheets and the mirrors often installed in elevator cars combine easily with the stainless steel typically used for the interior surfaces of elevators. Different shapes of stainless steel or coloured metal profiles can be used to add structure to the surface when using smaller glass panels, or if the joints are meant to be visible.



LACOBEL FOR ELEVATORS

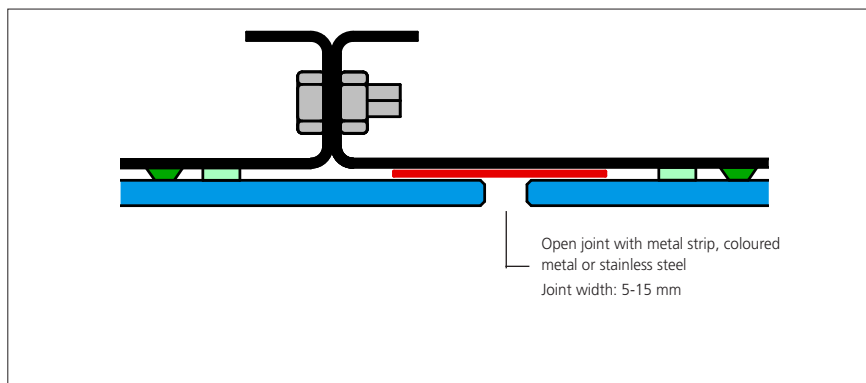

ELEVATOR CAR: HORIZONTAL CROSS SECTION WITH COLOURED JOINT

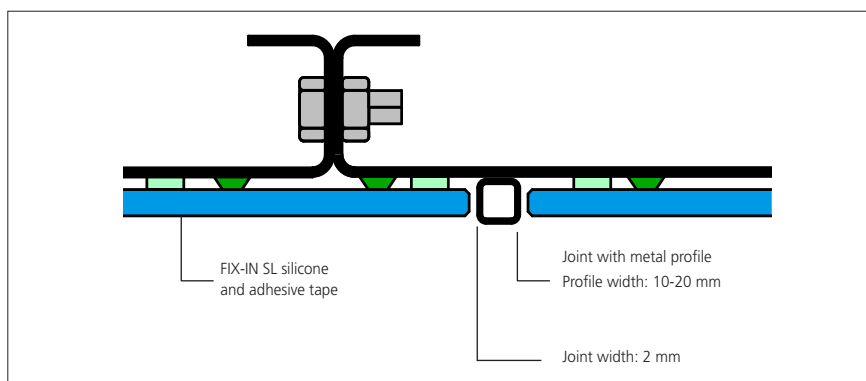

ELEVATOR CAR: HORIZONTAL CROSS SECTION WITH JOINT PROFILE

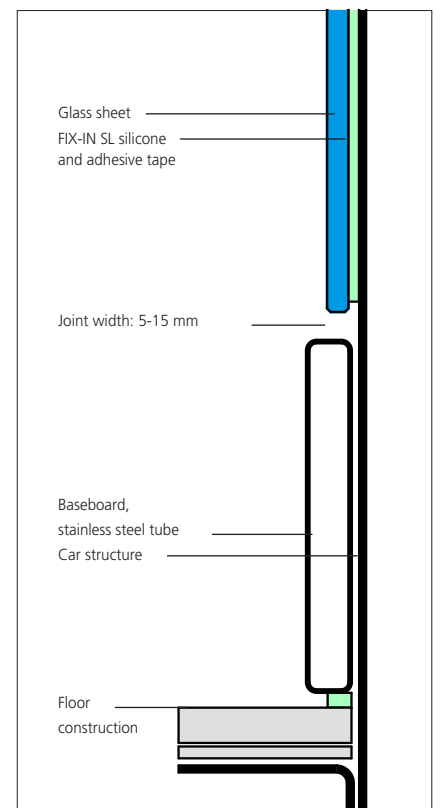

ELEVATOR CAR: VERTICAL CROSS SECTION WITH BASEBOARD



LACOBEL FOR ELEVATOR CABINS – COPYRIGHT: OSMA AUFZÜGE

6.5 FIX-IN SL SILICONE FOR PREFABRICATED PANELS

PREFABRICATION

Large projects are often under enormous time pressure, requiring special solutions to finish the interior in time while maintaining quality.

Prefabricated panels are one option for minimising installation time while ensuring a perfect result.

The substructure can be installed and adjusted on the construction site while the panels are being produced in the factory.

The final installation can then be done quickly, with prefabrication ensuring a high-quality final result.

Depending on the final system, the panels are easy to remove and replace.

All AGC products are suited to this approach. The sleek glass surface is emphasised when combined with other materials, such as stainless steel.

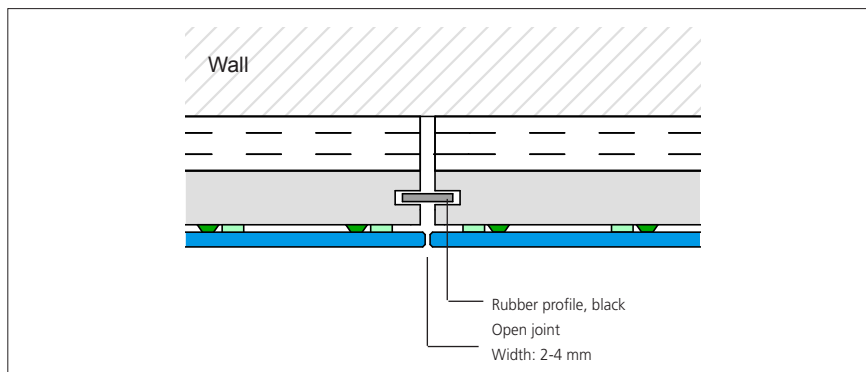

HORIZONTAL CROSS SECTION: JOINT

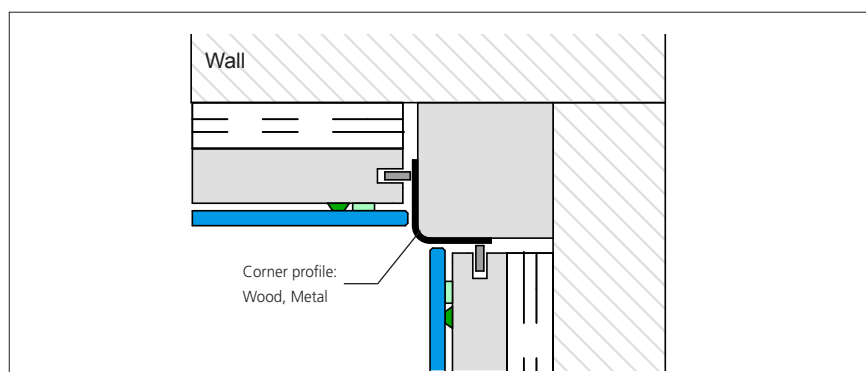

HORIZONTAL CROSS SECTION: CORNER SOLUTION

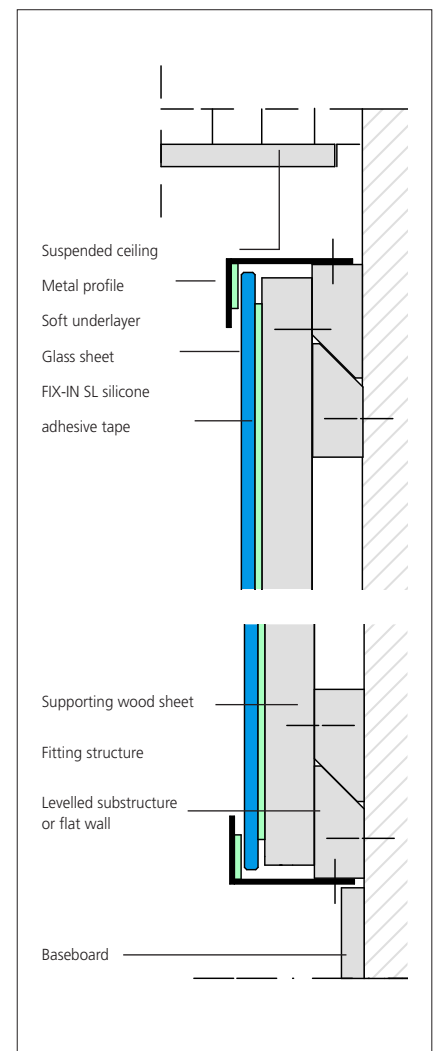

VERTICAL CROSS SECTION



LACOBEL

6.6 FIX-IN SL SILICONE FOR RENOVATION

SUBSTRATE: EXISTING TILES

Glass is easily installed directly on top of existing tiles when renovating tiled bathrooms and kitchens.

This method saves time and money during the construction phase.

Please follow the procedure described below.

CHECK THE TILES

Tiles should be checked for hollow areas. Loose parts must be removed and these areas filled.

The entire surface must be strong, even and flat enough to meet the surface quality requirements for substrates. (see chapter 3 in this guidelines).

CLEAN THE TILES

Tiles should be cleaned to remove any impurities which might reduce how well the silicone bonds to it.

Use water with a drop of ammonia (1L H₂O + max 200ml NH₃), and follow the supplier's instructions for safe use of the ammonia.

INSTALL THE GLASS

Follow AGC's instructions (as described in previous chapters) for the glass sheets, depending on whether or not the glass has a SAFE and SAFE+ backing film.



REFURBISHMENT: EXISTING BATHROOM

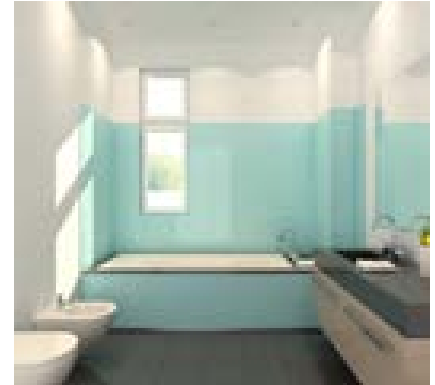

REFURBISHMENT: NEW BATHROOM

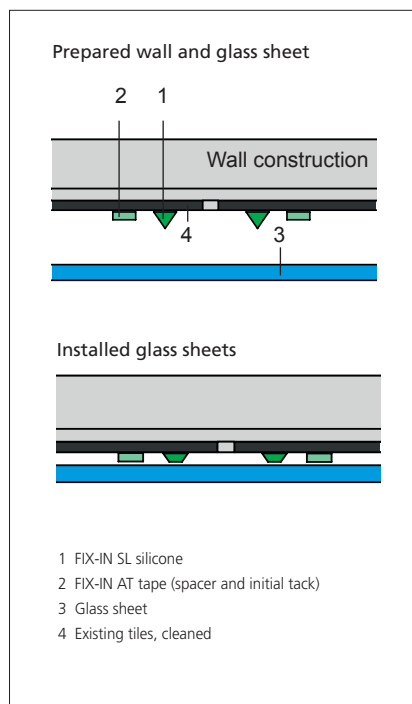

GLASS WITHOUT SAFETY BACKING FILM

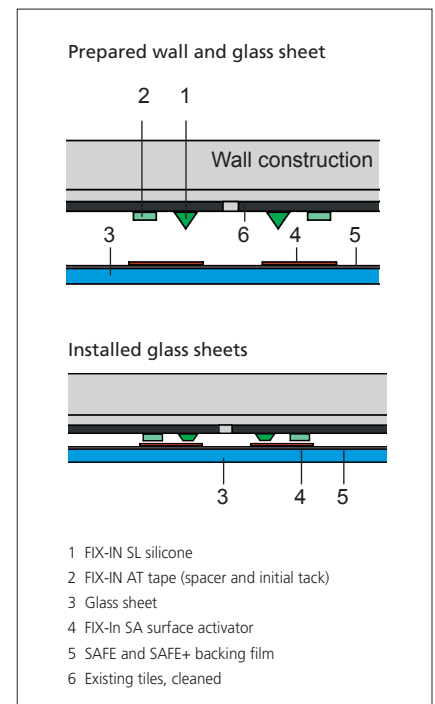

GLASS WITH SAFE AND SAFE+ BACKING FILM



REFURBISHMENT FIX-IN SL SILICONE

7.1 MECHANICAL FITTING

MECHANICAL FITTING

In addition to bonding technologies, mechanical fitting is another option for installing mirrors and painted glass sheets.

Lacobel, Matelac, Mirox, Lacobel T and Matelac T are designed to be used in combination with frames, profiles and clips, in both metal and wood structures.

Various manufacturers offer prefabricated systems for partitions and lightweight walls.

AGC recommends using the SAFE and SAFE+ backing film.

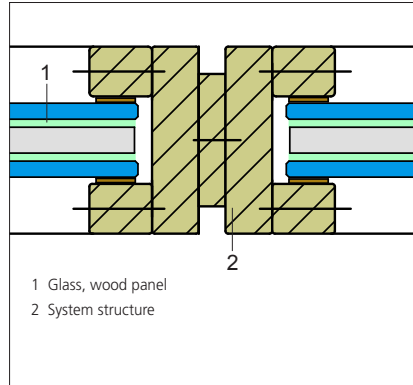

LACOBEL

WOOD CONSTRUCTION:
HORIZONTAL CROSS SECTION

MECHANICAL FITTING: MIROX

For mirrors, existing systems consist of U-shaped profiles screwed to the wall and finished with vertical edge profiles. When designing fitting systems and profiles, care must be taken to avoid immersing the mirror.

VENTILATION

To ensure correct mirror performance, care must be taken to prevent moisture or water from penetrating behind the mirror (see drawing of mechanical fitting).

Ventilation openings and a gap between the mirror and wall help ensure the necessary ventilation behind the glass to prevent the build-up of condensation.

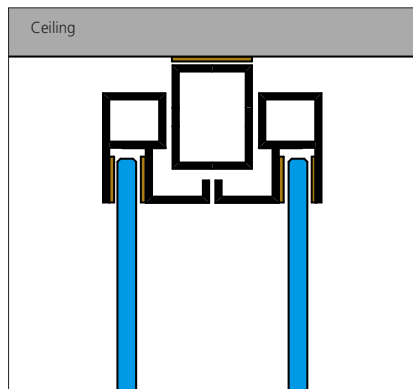

METAL STRUCTURE: VERTICAL CROSS SECTION

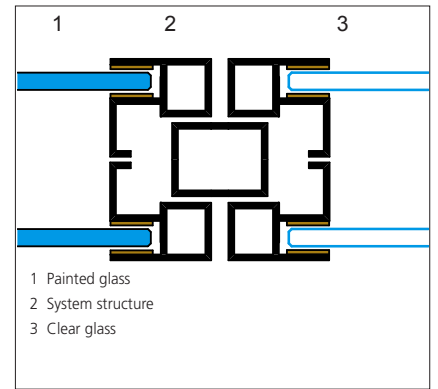

METAL STRUCTURE: HORIZONTAL CROSS SECTION



MIROX

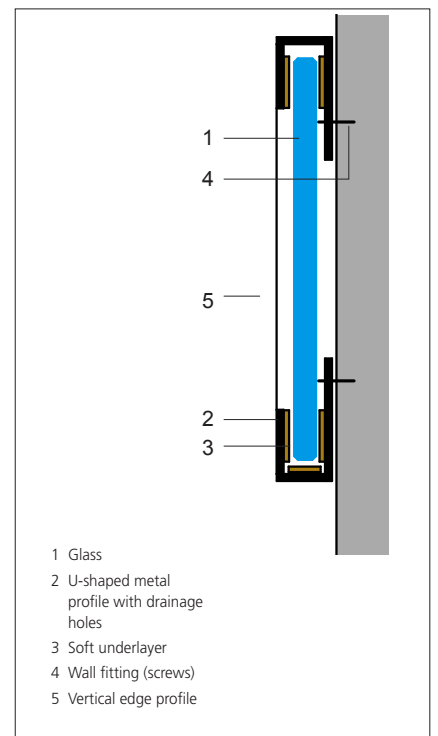

MECHANICAL FITTING: MIROX



LACOBEL FOR LIGHT WALL CONSTRUCTIONS

8.1 CLEANING

CLEANING RECOMMENDATIONS

Glass can get dirty, especially during the construction of a building.

Corrosive contamination must be avoided at all times, especially from plaster, mortar, concrete and cement slurry, all of which are alkaline and therefore capable of corroding the glass surface. Any such impurities must be washed off the glass immediately. Rinse with plenty of clean water to avoid scratching the surface. Use a soft clean sponge, cloth or chamois. Do not try to remove impurities while the glass is dry.

To protect the glass during construction, AGC recommends covering installed glass with sheets of plastic film.

The other teams working on the project should also be informed about handling the glass properly.

CLEANING: DETERGENTS

Detergents help with the cleaning process.

Use neutral commercial detergents designed to clean window glass. Do not use alkaline leachate, acids or liquids containing fluoride.

CLEANING MIROX

When cleaning the mirror, the edges must always be dried quickly and thoroughly.

Mirox mirrors can be cleaned with modern pH-neutral cleaning products.

IMPORTANT: Never use ammonia-based products or abrasive products (such as anti-limescale products) to clean Mirox.

CLEANING MATELAC AND MATELAC T

The acid-etched surface of Matelac and Matelac T is rougher than the untreated surface of Lacobel, Mirox and Lacobel T.

Dirt and other substances adhere better to the rough surface. Nevertheless it can be cleaned with neutral commercial detergents for normal day-to-day maintenance. Special care must, however, be taken during the installation of Matelac and Matelac T since dirt and other substances adhere.

Note: Silicone, cement slurry and similar materials cannot be removed from the surface of Matelac and Matelac T without leaving some residue.

CLEANING: SHARP OBJECTS

Never use sharp objects, such as scrapers, to clean the glass.



CLEANING: SPONGES

Soft sponges can be used to clean the surface. Use plenty of water to avoid scratching or otherwise damaging the surface of the glass.

Various products are available on the market. Melamine foam (marketed in some places as the 'magic eraser' or 'magic sponge') works very well, especially on Matelac and Matelac T. These products are available from drugstores.

Always test cleaning products on a sample sheet of glass.



SPONGE FOR CLEANING



LACOBEL

9.1 MISTAKES



WRONG: NO SURFACE ACTIVATOR SILICONE



RIGHT: SURFACE ACTIVATOR

WRONG

No FIX-IN SA surface activator applied to the SAFE and SAFE+ backing film. Adhesion of FIX-IN SL will be poor.

RIGHT

The surface activator (aerosol) is sprayed onto the SAFE and SAFE+ backing film on the back of the glass sheet (as explained in chapter 5).

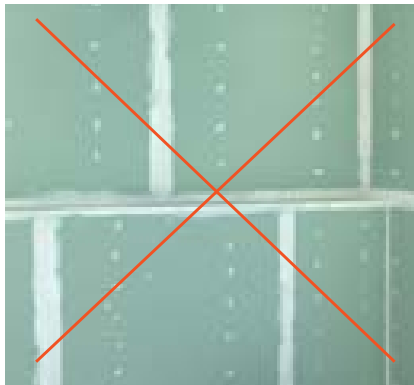

WRONG: NO WALL PRIMER



RIGHT: WALL PRIMER

WRONG

No FIX-IN wall primer applied to porous surfaces. Adhesion will be poor.

RIGHT

Apply the wall primer to ensure proper bonding on porous surfaces.

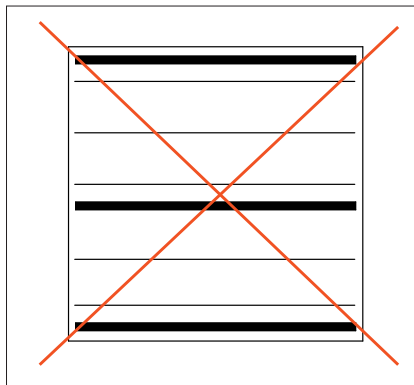

WRONG: HORIZONTAL LINES

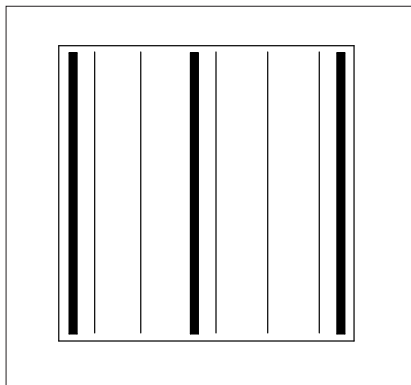

RIGHT: VERTICAL LINES

WRONG

FIX-IN SL silicone not applied in vertical lines. Drying process interrupted, no ventilation possible.

RIGHT

FIX-IN SL silicone applied in vertical lines.

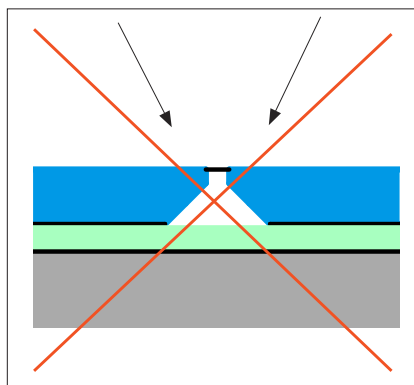

WRONG: EXCESSIVE PROCESSING OF EDGE

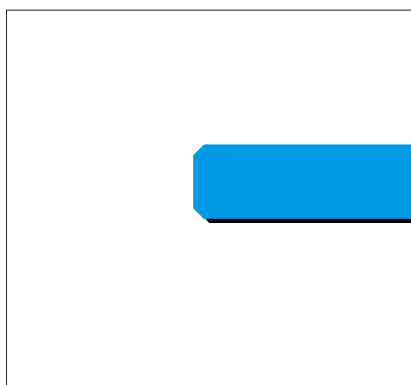

RIGHT: MINIMAL PROCESSING

WRONG

Too much edge beveling. Missing colour on back will be visible through the edge of the glass.

RIGHT

Keep beveling to a minimum.



WRONG: ADHESIVE NOT MATCHING TO GLASS



RIGHT: USE FIX-IN SYSTEM

WRONG

Using bonding materials that are not right for the glass and/or paint. The wrong bonding material can cause discolouration.

RIGHT

Use only approved accessories supplied by AGC.



WRONG: CLEANING WITH DIRTY AND DRY CLOTH



RIGHT: CLEANING WITH CLEAN CLOTH, WATER

WRONG

Using a dry, dirty cloth to clean the surface of the glass. Scratches will destroy the surface.

RIGHT

Use only clean materials and a plenty of water to clean the glass.



WRONG: STAIN ON THE GLASS



RIGHT: AVOID STAIN ON THE SURFACE

WRONG

Stain on the glass caused by cement slurry, surface activator or other substances is very difficult to remove. It is almost impossible to remove dirt from Matelac.

RIGHT

Protect the surface and avoid staining the glass.

10.1 SPECIFICATIONS

LACOBEL

Product:

Lacobel consists of float glass, one side of which (i.e. the back) is coated with an organic paint.

Paint system:

The paint must be applied by a curtain coater to ensure a uniform finish and perfect adhesion.

Lacobel paints contain no heavy metals.

UV resistance:

The product is light- and UV-resistant. The Lacobel colours are fixed during the production process.

Fire resistance:

Please see p. 18 of this guideline for further information.

MATELAC

Product:

Matelac consists of acid-etched float glass, one side of which (i.e. the back) is coated with an organic paint.

Paint system:

The paint must be applied by a curtain coater to ensure a uniform finish and perfect adhesion.

Matelac paints contain no heavy metals.

Acid-etched: The glass is treated with an acid to create a translucent, neutral, satin finish.

UV resistance:

The product is light- and UV-resistant. The Matelac colours are fixed during the production process.

Fire resistance:

Please see p. 18 of this guideline for further information.

MIROX

Product:

Mirox consists of float glass, one side of which (i.e. the back) is coated with a silver layer protected by an organic paint.

Paint system:

The paint must be applied by a curtain coater to ensure a uniform finish and perfect adhesion.

AGC's patented process with one layer of silvering and an additional protective layer on the back of the clear float glass creates the reflective effect of Mirox products.

This process provides enhanced resistance against corrosion and ageing.

UV resistance:

The product is light- and UV-resistant. The product colours are fixed during the production process.

Fire resistance:

Please see p. 18 of this guideline for further information.

AntiBacterial™ GLASS

Lacobel AB™

Mirox AB™

Planibel AB™

Product:

The production process involves diffusing silver ions in the upper layers of the glass. The ions interact with and destroy bacteria by disrupting their ability to divide. The antibacterial effect of the glass is continuous, particularly in the warm and moist conditions that encourage the growth of bacteria and mould.

The antimicrobial action of the silver ions inside the glass eliminates 99.9% of all bacteria that form on its surface whilst also preventing the spread of fungi.

Test results are available for a representative range of bacteria and fungi:

1. Bacteria
 - Staphylococcus aureus
 - Escherichia coli
 - Pseudomonas aeruginosa
2. Fungi
 - Aspergillus niger
 - Candida albicans

The testing procedure for AntiBacterial™ glass is based mainly on European standard EN 13697, with additional components derived from JIS Z 2801, EN 1276 and EN 1650.

LACOBEL T / MATELAC T

Lacobel T consists of float glass, one side of which (i.e. the back) is coated with enamel paint. Matelac T consists of float glass with one side acid-etched and the other coated with enamel paint.

The coating is an enamel that must be applied by a curtain coater to ensure a uniform finish and perfect adhesion.

Cutting and edge finishing must be done prior to tempering, without damaging the coating (on the back or at the edges).

After heat treatment, Lacobel T / Matelac T should be subjected to the following checks:

Thermally toughened glass must comply with EN 12150-1*.

UV resistance:

The product is light- and UV-resistant. The Lacobel T / Matelac T colours are fixed during the tempering process.

Fire resistance:

Please see p. 18 of this guideline for further information.

SAFE AND SAFE+ BACKING FILM

Matelac

Lacobel

Mirox

The SAFE and SAFE+ backing film consists of a PP or PET film with a minimum thickness of 50µ.

The film must be applied in the factory under defined conditions according to AGC's instructions.

Float glass with film must be classified as safety glass according EN 12600 class B.

Fire resistance:

Please see p. 18 of this guideline for further information.

FIX-IN SYSTEM

All of the components in the installation system must be approved to work together perfectly and seamlessly.

Only use AGC products so as to ensure durable installation and to prevent any risk of the paint discolouring, peeling or crackling.

The glass, the adhesives and the accessories must be stored, handled and installed in accordance with the latest version of AGC's guidelines, the Technical Data Sheets (TDS) and the Material Safety Data Sheets (MSDS) available on www.yourglass.com.

SUBSTRATE

The substrate (wall, brick, MDF, OSB etc.) must be even, with tolerances that do not exceed AGC's guidelines (see www.yourglass.com).

The surface must be clean and free of any dust, wax, oil or other impurities likely to compromise the bond between the glass and substrate.

The substrate must be designed to support the weight of the glass.

The structure must not warp, bend or otherwise deform during or after the installation of the glass.

The colour of the substrate surface must be uniform and may not shine through.

WALL PRIMER

Primer: substrate/wall:

According to AGC's guidelines, porous substrates (such as gypsum board, plaster, etc.) must be treated with a primer.

The primer must be applied to the entire surface of the wall that is to be glazed.

Supplier: AGC

FIX-IN PR wall primer for silicone bonding.

Wall size in m²

Amount needed: Depending on substrate

Application: roller, brush

SURFACE ACTIVATOR ON AGC SAFE AND SAFE+ BACKING FILM, SILICONE BONDING

AGC's surface activator must be part of the fitting system.

It must be applied to the SAFE and SAFE+ backing film to make the silicone adhere better.

The surface activator must be applied to all areas where silicone will later be applied using the wipe on wipe off method.

Supplier: AGC

Product: FIX-IN SA

Application by spray can.

*Or equivalent local standards for countries outside the EU.

10.2 SPECIFICATIONS - FUNCTIONAL DESCRIPTION AND INSTALLATION

SILICONE GLUE

AGC's silicone glue must be part of the fitting system.

The product must be applied in vertical lines according to AGC's instructions.

AGC's SAFE and SAFE+ backing film must be pre-treated with the FIX-IN SA surface activator. After installation, the glass sheets must be supported for at least 48 hours while the silicone cures .

Additional silicone must be applied in and around any cut-outs before the glass is installed.

Glass sheets must be mounted evenly, whether horizontally or vertically. Joints must be parallel, with no mismatch.

A gap of 3.2 mm between the back of the glass and the substrate must be maintained using AGC adhesive tape. The FIX-IN AT adhesive tape must be part of the fitting system.

The joints can be filled 48 hours after installation.

Supplier: AGC

Product: FIX-IN SL

Amount needed: depends on the thickness of the glass.

CUTTING AND EDGE FINISHING

Lacobel, Matelac, Mirox: processing **after** painting

Lacobel T / Matelac T: processing **before** tempering.

Glass sheets must be cut and edge-finished by the processor.

Cutting and edge finishing must be done without damaging the coating, as per AGC's instructions (latest version) and in accordance with the fitter's requirements on the project site.

JOINT FILLER

AGC's joint filler must be part of the fitting system.

The product must be used according to AGC's instructions.

The joints and the front edges of the glass must be clean and free of any glue or dirt.

Masking tape must be applied to the surface of the glass to prevent contamination.

Joints must be filled in fully and smoothed out before the adhesive forms a skin.

Manufacturer: AGC

Products: FIX-IN SL - silicone adhesive, transparent.

Length of joints: Number of linear metres

HANDLING AND INSTALLATION

The glass sheets must be handled and installed in compliance with the latest version of AGC's installation guidelines (see www.yourglass.com).

During installation, special care must be taken to avoid scratching the painted surface of the glass and damaging the edges. The surface must be protected after installation.

Stain on the glass caused by cement slurry, surface activator or other substances is very difficult to remove, particularly with Matelac and Matelac T. Once the glass is contaminated with these substances, they cannot be removed without leaving some residue.

INITIAL CLEANING

After installation, the glass must be cleaned according to AGC's instructions.

11.1 DISCLAIMER

1. The present document (the "Document") is the full and exclusive ownership of AGC Glass Europe S.A., with corporate seat at Avenue Jean Monnet 4, 1348 Louvain-la-Neuve, Belgium, (hereafter "AGC Glass Europe"), and is part of the technical documentation set of AGC Glass Europe ("AGC Technical Library"). The copyright on all pictures and other content in the Document is either owned or licensed by AGC Glass Europe.
2. AGC Glass Europe hereby authorizes the person who has downloaded the present file (hereafter the "Customer") to use the Document as a reference or example, each time that the Customer wishes to incorporate an AGC glass product in a building structure, so as to facilitate the Customer's technical work and assist it in the finding of technical solutions.
3. The above mentioned right to use the Document is granted by AGC Glass Europe free of charge and the Customer should on a regular basis check for any updates of the Document on www.yourglass.com or by consulting his/her local AGC contact.
4. To the maximum extent permitted under applicable law, AGC is not liable for any damages or losses whatsoever that could result, whether directly and/or indirectly, from the use of the Document by the Customer, and the Customer shall always hold AGC harmless, and indemnify AGC in full, from any recourses, actions, demands, proceedings, suits, or claims whatsoever, whether in Court or otherwise, initiated by third parties in relation to the use of the Document.
5. The Customer shall contact in due time an AGC expert in order to determine jointly the appropriate composition and specifications of the glass products to be used in the project.
6. By using the Document, the Customer expressly and irrevocably acknowledges and agrees having read, understood and agreed with all the terms and conditions mentioned in the Document.

AntiBacterial™ GLASS

AGC has taken into consideration the requirements set out in European Directive 98/8/EC of February, 1998 (hereinafter the "Directive") replaced by European Regulation 528/2012 of May 22, 2012 (hereinafter the "Regulation"), the last which will replace, on the date of its entry into force, the national regimes of the European Union Member States, and imposes the requirement of obtaining prior authorization for biocidal products containing any active substances approved and lays down rules for the placing on the market in the European Union of 'treated articles' containing any active substances approved.

At the present time, in compliance with the Directive, the active substance found in AB glass [Silver - CAS 7440-22-4] is still subject to examination prior to approval at EU level, for which the review duration was extended to September 15, 2015.

In the meantime, AGC will attempt, in so far as possible, to take into account specific national rules, which are likely to continue being applied in the Member States and which will maintain certain specific temporary systems likely to be different from the system eventually set out in the Regulation.

COPYRIGHT

The copyright for all pictures is owned by AGC, unless otherwise indicated.

11.2 INDEX OF SECTIONS

ALPHABETICAL ORDER

Adhesive Tape and Curing Time	30	Initial Cleaning	56	Restrictions	3
AntiBacterial™ (AB™) Glass	19	Install the Glass	46	SAFE and SAFE+ backing film	55
Antibacterial™ Glass	54, 57	Installation Sequence	30	SAFE and SAFE+ backing film: Application	21
Antibacterial™ Glass: Compliance	19	Interior Glass Applications	3	SAFE and SAFE+ backing film: Production	21
Antibacterial™ Glass:	19	Joint Dimension	34	Silicone Bonding: Restrictions	34
Interior applications		Joint Filler	56	Silicone Glue	56
Antibacterial™ Glass: Performance	19	Joint Maintenance	35	Single burning item test (EN13823)	22
Antibacterial™ Glass: Processing	19	Joint Sealing (Not for Mirox)	31	Soft Body Impact Test (En 12600)	22
Arrissed Edge	25	Joints	34	Splashbacks	41
Back of the Glass	9	Lacobel	5, 7, 41, 54	Standard Colours	6
Bevelled Edge	25	Lacobel T / Matelac T	3, 5, 8, 55	Substrate	55
Bonding: Introduction	28	Lacobel T / Matelac T: Exterior Use	16	Substrate Colour	23
C-Shape	25	Lacobel T / Matelac T: Fitting	16	Substrate: Existing Tiles	46
Calorific potential test (EN ISO 1716)	22	Lacobel T / Matelac T:	41	Substrates	23
Check the Tiles	46	Heat-Resistant Glass		Surface Activator on AGC Safety Backing Film, Silicone Bonding	55
Clean the Tiles	46	Lacobel T / Matelac T: Interior Use	16	Tape as a Spacer	35
Cleaning Matelac and Matelac T	50	Lacobel T / Matelac T:	16	The FIX-IN SL System	31
Cleaning Mirox	50	Moisture Resistance		Thickness Of the Glass	9
Cleaning Recommendations	50	Lacobel T / Matelac T: Production	16	Touch-Up Paint	9
Cleaning: Detergents	50	Lacobel T / Matelac T: Properties	16	U-Shape	25
Cleaning: Sharp Objects	50	After Tempering		Use of FIX-IN SL	33
Cleaning: Sponges	50	Lacobel: Exterior Use	10	UV Resistance	9
Colour Samples	6	Lacobel: Fitting	10	Ventilation	48
Coloured Joints	34	Lacobel: Interior Use	10	Wall Primer	55
Copyright	57	Lacobel: Moisture Resistance	10	Wet and Humid Areas	40
Corner: Profile Solution	26	Lacobel: Production	10		
Corners	26	Lacobel: Properties	10		
Corners: Glass Solution	26	Masking the Joints	34		
Custom Colours	6	Matelac	5, 8, 54		
Cut-Outs: Installation	35	Matelac: Exterior Use	12		
Cutting and Drilling In the Factory	27	Matelac: Installation Fitting	12		
Cutting and Drilling Lacobel T / Matelac T	27	Matelac: Interior Use	12		
Cutting and Drilling On Site	27	Matelac: Moisture Resistance	12		
Cutting and Edge Finishing	56	Matelac: Production	12		
Disclaimer	57	Matelac: Properties	12		
Edge Finishing	25	Matelac: Surface Protection	35		
Elevators: Cars and Shafts	42	Mechanical Fitting	48		
Expansion Joints	24	Mechanical Fitting: Mirox	48		
Fitting – Sleeves	35	Metallic Colours: Moisture Protection	40		
FIX-IN PR Substrate Primer	31	Mirox	5, 36, 54		
FIX-IN PR Wall Primer	34	Mirox: Exterior Use	14		
FIX-IN SA Surface Activator	31, 34	Mirox: Fitting	14		
FIX-IN SL Silicone	31	Mirox: Interior Use	14		
FIX-IN SL: Silicone Bonding	28	Mirox: Mechanical Fitting	36		
FIX-IN System	55	Mirox: Moisture Resistance	14		
Flatness of the Wall	23	Mirox: Production	14		
Furniture	38	Mirox: Properties	14		
Handling and Installation	56	Mirox: Ventilation	36		
Ignitability (EN ISO 11925-2)	22	Moisture Protection	40		
Impact Test Results	22	Orientation of the Glass Sheets	9		
Important	3	Prefabrication	44		
		Processing the Glass	27		
		Products and specifications	18		
		Projects	9		

AUSTRIA
AGC Interpane
T: +49 39 205 450 440 - F: +49 39 205 450 449
igd@interpane.com

BELGIUM
AGC Glass Europe
T: +32 2 409 30 00 - F: +32 2 672 44 62
sales.belux@eu.agc.com

BULGARIA / MACEDONIA
AGC Flat Glass Bulgaria
T: +359 2 8500 255 - F: +359 2 8500 256
bulgaria@eu.agc.com

CROATIA / SLOVENIA / BOSNIA & HERZEGOVINA
AGC Flat Glass Adriatic
T: +385 1 6117 942 - F: +385 1 6117 943
adriatic@eu.agc.com

CZECH REPUBLIC / SLOVAKIA
AGC Flat Glass Czech
T: +420 417 50 11 11 - F: +420 417 502 121
czech@eu.agc.com

ESTONIA
AGC Flat Glass Baltic
T: +372 66 799 15 - F: +372 66 799 16
estonia@eu.agc.com

FINLAND
AGC Flat Glass Suomi
T: +358 9 43 66 310 - F: +358 9 43 66 3111
sales.suomi@eu.agc.com

FRANCE
AGC Glass France
T: +33 1 57 58 30 31 - F: +33 1 57 58 31 63
sales.france@eu.agc.com

GERMANY
AGC Interpane
T: +49 39 205 450 440 - F: +49 39 205 450 449
igd@interpane.com

GREECE / MALTA / ALBANIA
AGC Flat Glass Hellas
T: +30 210 666 9561 - F: +30 210 666 9732
sales.hellas@eu.agc.com

HUNGARY
AGC Glass Hungary
T: +36 20 9732 987
hungary@eu.agc.com

ITALY
AGC Flat Glass Italia
T: +39 02 626 90 110 - F: +39 02 65 70 101
market.italia@eu.agc.com

LATVIA
AGC Flat Glass Baltic
T: +371 6 713 93 59 - F: +371 6 713 95 49
latvia@eu.agc.com

LITHUANIA
AGC Flat Glass Baltic
T: +370 37 451 566 - F: +370 37 451 757
lithuania@eu.agc.com

NETHERLANDS
AGC Flat Glass Nederland
T: +31 344 67 97 04 - F: +31 344 67 96 99
sales.nederland@eu.agc.com

POLAND
AGC Glass Poland
T: +48 22 872 02 23 - F: +48 22 872 97 60
polska@eu.agc.com

ROMANIA
AGC Flat Glass Romania
T: +40 318 05 32 61 - F: +40 318 05 32 62
romania@eu.agc.com

RUSSIA
AGC Glass Russia
T: +7 495 411 65 65 - F: +7 495 411 65 64
sales.russia@eu.agc.com

SERBIA / MONTENEGRO
AGC Flat Glass Jug
T: +381 11 30 96 232 - F: +381 11 30 96 232
jug@eu.agc.com

SPAIN / PORTUGAL
AGC Flat Glass Ibérica
T: +34 93 46 70760 - F: +34 93 46 70770
sales.iberica@eu.agc.com

SWEDEN / NORWAY / DENMARK
AGC Flat Glass Svenska
T: +46 8 768 40 80 - F: +46 8 768 40 81
sales.svenska@eu.agc.com

SWITZERLAND
AGC Interpane
T: +49 39 205 450 440 - F: +49 39 205 450 449
igd@interpane.com

UKRAINE
AGC Flat Glass Ukraine
T: +380 44 230 60 16 - F: +380 44 498 35 03
sales.ukraine@eu.agc.com

UNITED KINGDOM
AGC Glass UK
T: +44 1788 53 53 53 - F: +44 1788 56 08 53
sales.uk@eu.agc.com

OTHER COUNTRIES
AGC Glass Europe
T: +32 2 409 30 00 - F: +32 2 672 44 62
sales.headquarters@eu.agc.com