

VMX

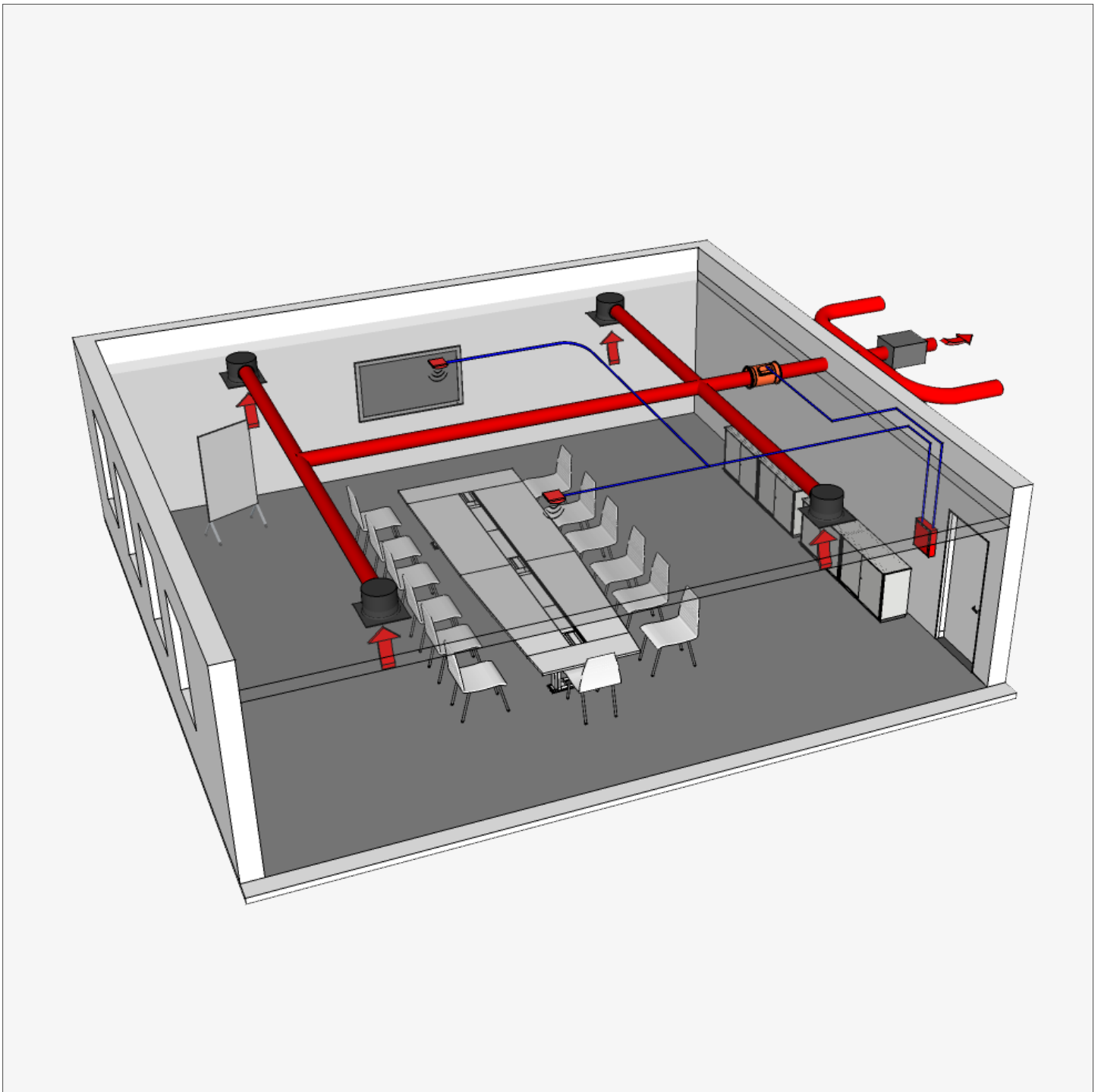

Demand controlled ventilation for non residential buildings



1. Introduction	3	9.3. Description	22
2. System components	4	9.4. Assembly	22
3. Functions	5	9.5. Electrical connection	22
4. Unizone or multizone management	6	9.6. Wiring	23
4.1. Unizone	6	9.7. Interpretation of sensor signals	24
4.2. Multizone	6	9.8. Operating modes	24
5. Installation of electrical system	7	9.9. Maintenance	25
5.1. Wiring	7	10. VMX relay out module	26
5.2. Unizone management	8	10.1. Field of application	26
5.3. Multizone management	9	10.2. Description	26
6. Motorised valves for VMX system	10	10.3. Dimensions	26
6.1. Description of motorised valves	10	10.4. Settings	26
6.2. Description of motorised valves	10	10.5. Assembly	27
6.3. Assembly	11	10.6. Electrical connection	27
6.4. Assembly of motorised valves and regulation of nominal flow	11	11. VMX contact in module	28
6.4.1. Regulation of nominal flow	11	11.1. Field of application	28
6.4.2. Assembly of motorised valves	12	11.2. Description	28
6.5. Electrical connection	13	11.3. Dimensions	28
6.6. Settings	13	11.4. Settings	28
6.7. Maintenance	13	11.5. Assembly	29
6.8. Airflow noise transmitted in the network by the valves	14	11.6. Electrical connection	29
6.8. Noise radiated by the valves (produced in the false ceiling)	14	12. VMX in/out 0-10 V module	30
7. Main module (main VMX)	15	12.1. Field of application	30
7.1. Field of application	15	12.2. Description	30
7.2. Description	15	12.3. Dimensions	30
7.3. Dimensions	15	12.4. Settings	30
7.4. Reduced flow management	15	12.5. Assembly	31
7.5. Assembly	16	12.6. Electrical connection	31
7.6. Electrical connection	16	13. Diffusers	32
7.7. Powering up the system	16	14. Fans	33
7.8. Start-up cycle	16		
7.9. Module configuration	17		
7.10. Memorising the system settings	17		
7.11. Maintenance	18		
7.12. Power supply / transformer	18		
8. VMX S-PRE optical sensor	19		
8.1. Field of application	19		
8.2. Description	19		
8.3. Dimensions	19		
8.4. Assembly	19		
8.5. Electrical connection	20		
8.6. Wiring	20		
8.7. Interpretation of signals	20		
8.8. Function modes	20		
8.9. Maintenance	21		
9. VMX S-CO2 CO ₂ Sensor	22		
9.1. Field of application	22		
9.2. Dimensions	22		

1. INTRODUCTION

VMX is an intelligent ventilation system for offices and other service premises enabling the automatic modulation of airflows in accordance with such parameters as the level of CO₂, presence, motion, or other sensors transmitting information. The modulation of airflows in accordance with the needs offers important savings on thermal losses due to air renewal as well as on fan consumption, whilst at the same time optimising indoor air quality.

The most important innovation in this system resides in the fact that it uses a specific multiplexing principle, which allows the system to be simplified considerably by limiting the number of wires and connections between the different components: **Two wires are suf-**

icient to ensure both the powering of and the communication between the system components.

Areas of use:

- meeting rooms,
- offices,
- education establishments (schools),
- restaurant dining rooms,
- cinemas, etc.

Construction and installation

The VMX system can be installed in new or renovated premises. It is generally installed in false ceilings.

Compatible ventilation systems

- Mechanical supply ventilation
- Mechanical exhaust ventilation
- Mechanical supply and exhaust ventilation with or without heat recovery

Operating conditions

- All system components:
- Operating temperature: from +5°C to +40°C
 - Relative operating humidity: maximum 80% RH at 31°C, with lineal decrease to 50% RH at 40°C.
 - IP 20

 These instructions should be kept and made accessible to all persons involved in maintenance (operational parameters and diagnostics).



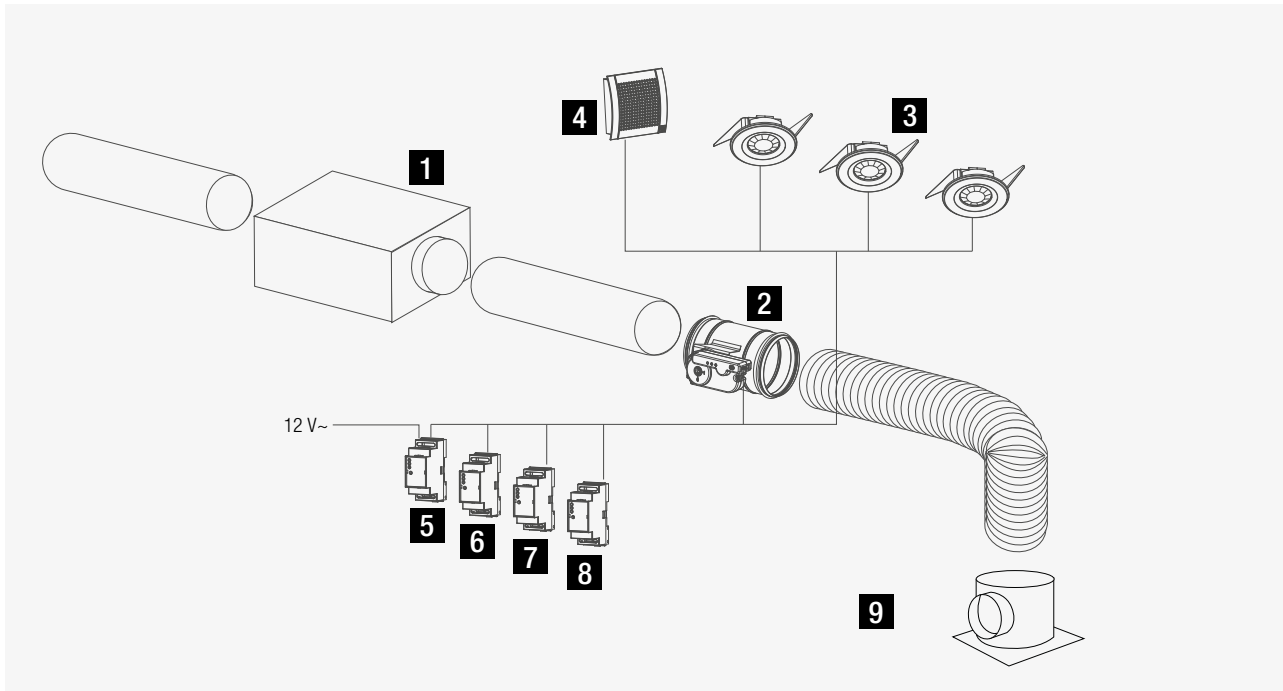





The VMX system is an intelligent ventilation system which can be modulated and fully configured. It can be adapted to most types of equipment commonly used for ventilation and it can communicate with the majority of external systems (to provide information or to comply with instructions). The VMX system is composed of the following elements (see diagram). Several valves and diffusers can be connected to the same ventilation unit (one main module per ventilation unit).

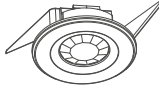
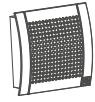

- | | | |
|---------------------------------------|--|---|
| 1 Fan | 4 CO ₂ sensor (optional) | 7 VMX Contact IN module (optional) |
| 2 Motorised valves(s) | 5 VMX Main Module (compulsory) | 8 VMX Relay OUT module (optional) |
| 3 Optical sensor(s) (optional) | 6 VMX IN/OUT 0-10 V Module (optional) | 9 Diffuser(s) |

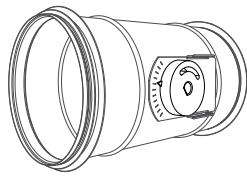
2. SYSTEM COMPONENTS

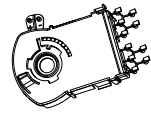
The VMX system is composed of the following elements (the ducts and the fans are not shown, they can be chosen independently).

Category	View	Component name	Description
Sensors		VMX S-PRE	Optical sensor for the VMX system. It measures presence or motion.
		VMX S-CO2	Carbon dioxide sensor for the VMX system.
Modules	   	VMX Main	Main module for the VMX system.
		VMX Relay Out	Optional module for the VMX system. System status output.
		VMX Contact In	Optional module for the VMX system. External instructions input
		VMX In/Out 0-10 V	Optional module for the VMX system. System status Output and/or external instructions Input.
Valves		VFC 125	TROX valve for VMX system. Diameter 125mm. Constant flow mechanical regulator (self-regulating). Pressure band: 30 to 500 Pa. On-site flow regulation between 36 and 360 m ³ /h
		VFC 160	TROX valve for VMX system. Diameter 160mm. Constant flow mechanical regulator (self-regulating). Pressure band: 30 to 500 Pa. On-site flow regulation between 65 and 666 m ³ /h
		VFC 200	TROX valve for VMX system. Diameter 200mm. Constant flow mechanical regulator (self-regulating). Pressure band: 30 to 500 Pa. On-site flow regulation between 90 and 900 m ³ /h
		VFC 80 VFC 100 VFC 250	TROX valves for VMX system. Diameters 80, 100 & 125mm. Constant flow mechanical regulator (self-regulating). Available by special request.
Motorisation valves		VMX Drive	Drive / motor for VMX system valves
		VMX VFT	Base for VFC series TROX valves
Diffuser		XARTO	Helical jet input or output airflow TROX XARTO diffuser. Airflow 324 to 990 m ³ /h. Exists in different designs, with a round or square facing. On special request only.

3. FUNCTIONS

With its different types of sensors and modules, the VMX system offers numerous possibilities. The table below summarises the main functions of the system according to the components selected. The table does not include the necessary electrical components (circuit-breaker and power supply) or the airflow components (motorised valves, ducts, fan).

Available functions	Sensors		Modules				Connected components		
	VMX S-PRE	VMX S-CO2	VMX Main	VMX Relay Out	VMX Contact In	VMX In/Out 0-10 V	Component to connect to VMX Relay Out	Component to connect to VMX Contact In	Component to connect to VMX In/Out 0-10 V
To activate maximum ventilation when a presence is detected	1 to 8		1						
To modulate the rate of ventilation proportionally in accordance with the rate of motion	1 to 8		1						
To activate maximum ventilation when the CO ₂ exceeds a threshold		1	1						
To modulate the rate of ventilation in multizones proportionally in accordance with the level of CO ₂		1	1						
To signal breakdown(s) in the system			1	1 to 2			Warning light, audible alarm or BMS		
To signal the correct functioning of the system			1	1 to 2			Warning light or BMS		
To indicate the rate of ventilation			1	1 to 2			BMS		
To signal a presence (time out 5 min)	1 to 8		1	1 to 2			Warning light, audible alarm or BMS		
To signal a presence (time out 20 min)	1 to 8		1	1 to 2			Warning light, audible alarm or BMS		
To inform or drive an external appliance when the threshold of CO ₂ is exceeded		1	1	1 to 2			Warning light, audible alarm or BMS		
To inform or drive an external appliance when there is a peak flow demand			1	1 to 2	1		Warning light, audible alarm or BMS	Push button, clock, window contact, etc	
To inform or drive an external appliance when there is a minimum flow demand			1	1 to 2	1		Warning light, audible alarm or BMS	Push button, clock, window contact, etc	
To activate maximum ventilation			1		1			Push button, clock, window contact, etc	
To activate minimum ventilation			1		1			Push button, clock, window contact, etc	
To modulate the rate of ventilation in unizones proportionally in accordance with a registered rate			1			1			BMS
To communicate the level of CO ₂ measured		1	1			1			BMS
To control a 0-10 V system in accordance with the level of CO ₂ measured		1	1			1			System with 0-10 V input, fan with 0-10 V input
To communicate the level of motion measured	1		1			1			BMS
To control a 0-10 V system in accordance with the level of motion measured	1		1			1			System with 0-10 V input, fan with 0-10 V input
To communicate the rate of ventilation	1		1			1			BMS
To control a 0-10 V system in accordance with the rate of ventilation	1		1			1			System with 0-10 V input, fan with 0-10 V input

4. UNIZONE OR MULTIZONE MANAGEMENT

The VMX system allows several ways of managing ventilation, in "Unizone" or in "Multizone".

4.1. UNIZONE

Under the "Unizone" approach, each zone has its own fan. This can be controlled by one or more sensors associated with a main module and one or more optional modules.

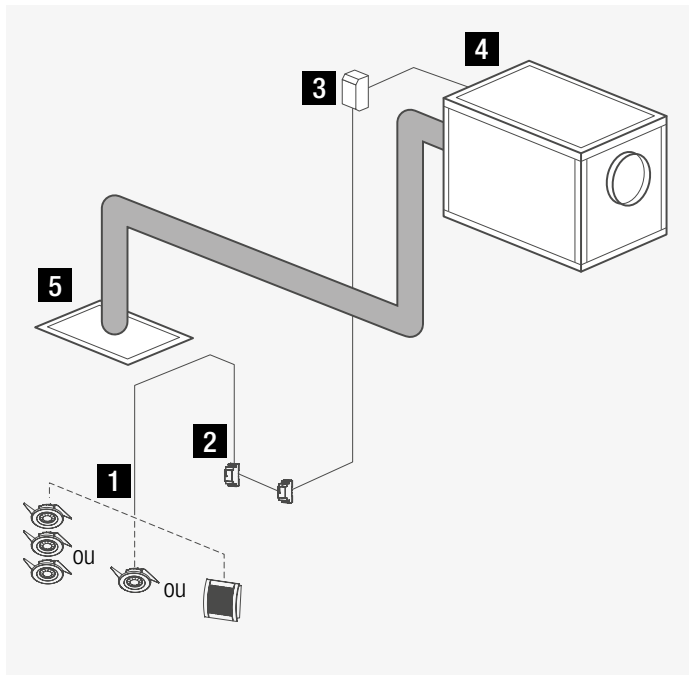

example of set-up

- 1** VMX S-CO2 or VMX S-PRE sensors
- 2** Main module and other optional modules:
 - Relay OUT* if control of fan is on full or little (threshold)
 - or IN/OUT 0-10 V if control is proportional
- 3** Frequency (or voltage) regulator or power relay (if motor > 0.5 A at maximum)
- 4** Fan
- 5** Diffuser

4.2. MULTIZONE

Under the so-called "Multizone" approach, several zones or rooms are served by the same fan. Then there will be one VMX system per zone, each with motorised valves connected to the fan. Each zone or room will then need a main module (VMX Main) and one or more sensors. Each main module may be supplemented where necessary with optional modules (Contact IN, Relay OUT, IN/OUT 0-10V).

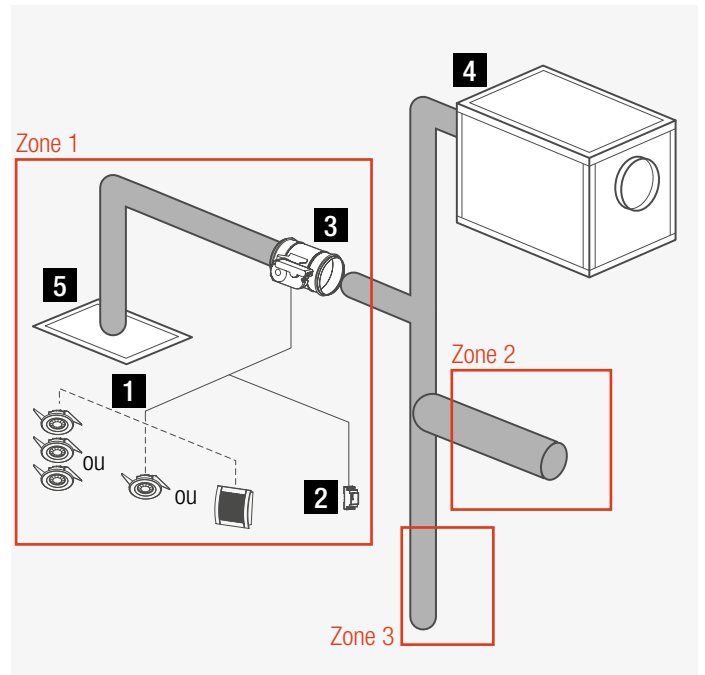

example of set-up

- 1** VMX S-CO2 or VMX S-PRE sensors
- 2** Main module and other optional modules
- 3** Motorised valves
- 4** Fan
- 5** Diffuser

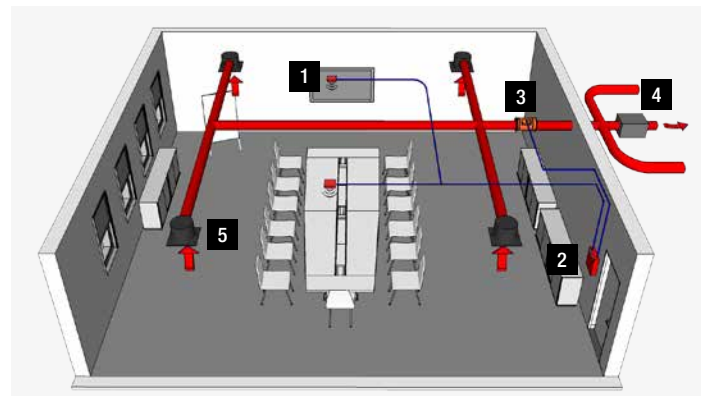
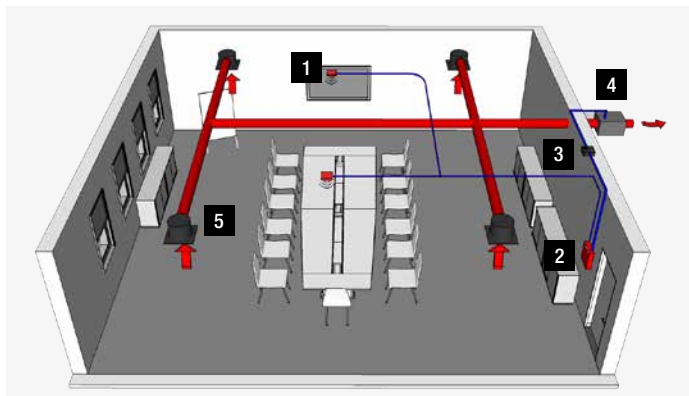

* in the case of a voltage regulator, replace the Relay OUT module with an IN/OUT 0-10 V module

5. ELECTRICAL INSTALLATION OF THE SYSTEM

 Read the instructions carefully before installing and using this appliance
 The manufacturer cannot be held responsible and declines all responsibility in case of damages suffered by persons or property as a result of improper use or incorrect installation of the products affected by this warning.
 These materials should be installed by suitably qualified persons.
 Bad connections may wire to the destruction of the modules, valves and sensors.

Note: the voltages on the bus wires (BUS-, BUS+ and V+) do not present any danger to persons (less than 12 V).

Before starting installation

- for each part, locate the positioning for each component and the duct passages, taking special care to limit the loss of airflow loads and the length of the wires; the sensors should be positioned and distributed so as to provide a relevant measurement of the parameter(s) transmitted.
- position the components so that the required lengths of the wires can be determined.
- do not connect to the power supply before installation has been completed.

 Each system (one system = one VMX Main module) should have its own circuit breaker and be connected directly to the electrical switchboard especially with a view to enabling operations and maintenance.

5.1. WIRING

The main advantage of the bus solution for the power supply implemented in the VMX system is that the wiring is so simple; only two wires are required to ensure the power supply and communication with the different components.

Characteristics of the wires

Maximum lengths for wires between the main module and the components

Section: 1.5 or 2.5 mm²

The wiring used should comply with the regulations in force.

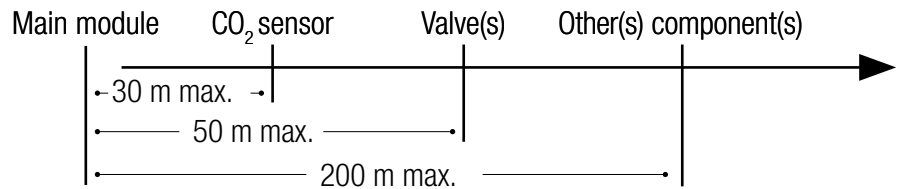

For each component

Connect all the black terminals together and the orange terminals together.

For the CO₂ sensor

In addition to the orange and black terminals, connect the V+ terminal on the main module to the CO₂ sensor*.

Examples of wiring diagrams can be found on the following pages.

Each of the components of the VMX system is connected using two wires. The orange wire is connected to the orange terminal, the black wire is connected to the black terminal. Section 1.5 or 2.5 mm².

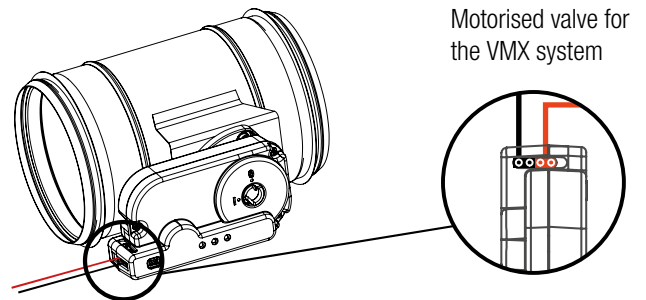

*supplementary power supply for the CO₂ module only

5.2. UNIZONE MANAGEMENT

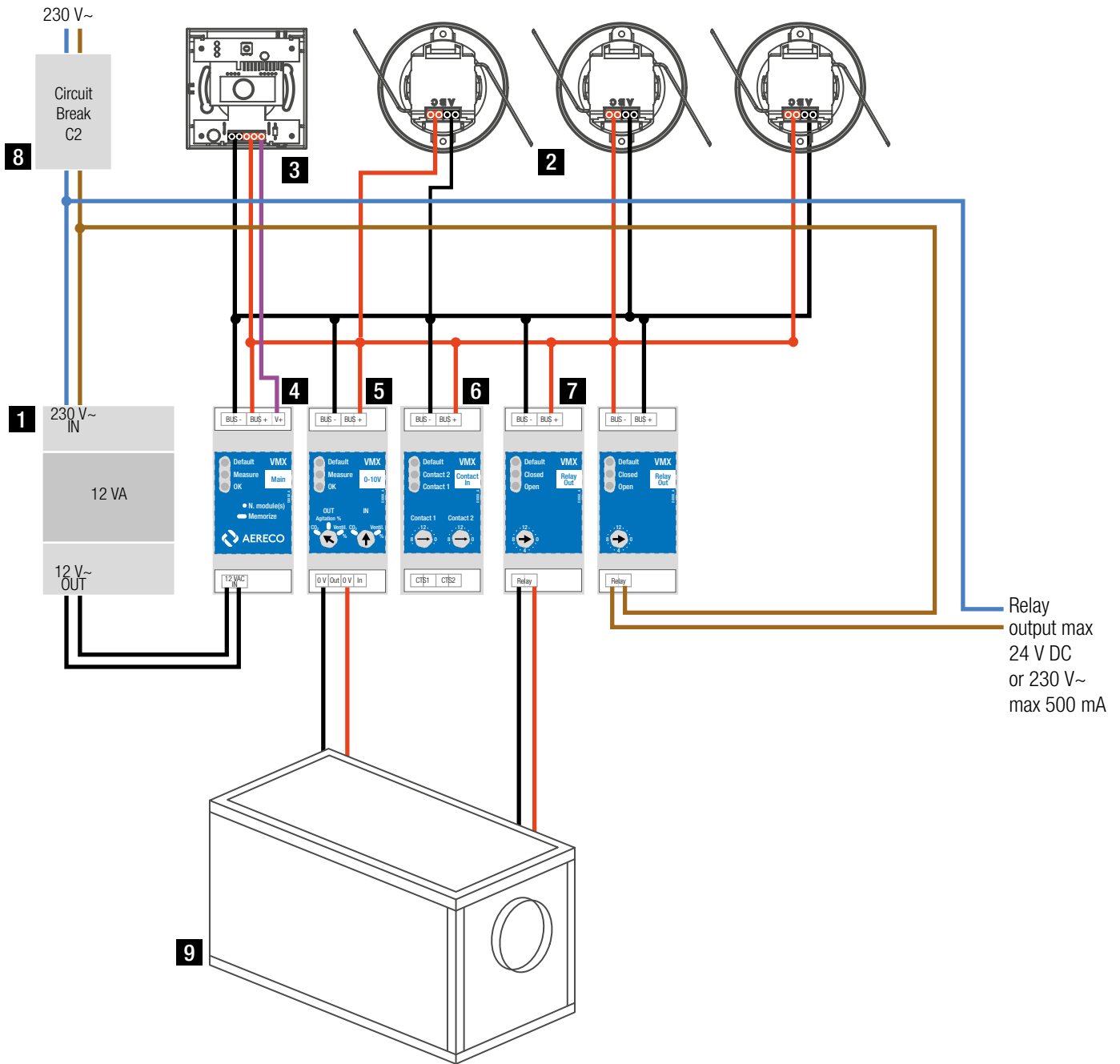

For "full or little" presence or CO₂ ventilation (threshold): main module to be configured in "full or little" mode
 For motion or proportional CO₂ ventilation: main module to be configured in "proportional" mode.

- 1** 230 V~ /12 V ~ (12 VA) Transformer
- 2** VMX S-PRE optical sensors
- 3** VMX S-CO2 CO₂ Sensor
- 4** VMX Main module
- 5** VMX IN/OUT 0-10 V module

- 6** VMX Contact IN module
- 7** VMX Relay Out module
- 8** C2 circuit breaker
- 9** Fan.

Proportional control requires a VMX IN/OUT 0-10 V module connected to the frequency or voltage regulator of the fan.
 "Full or little" control requires a VMX Relay OUT module connected to the fan (via power relay if the fan is > 0.5A)

Note: Each module contains 2 black terminals and 2 orange terminals to make the wiring simpler and to minimise the use of connector boxes.

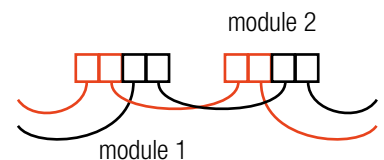

5.3. MULTIZONE MANAGEMENT

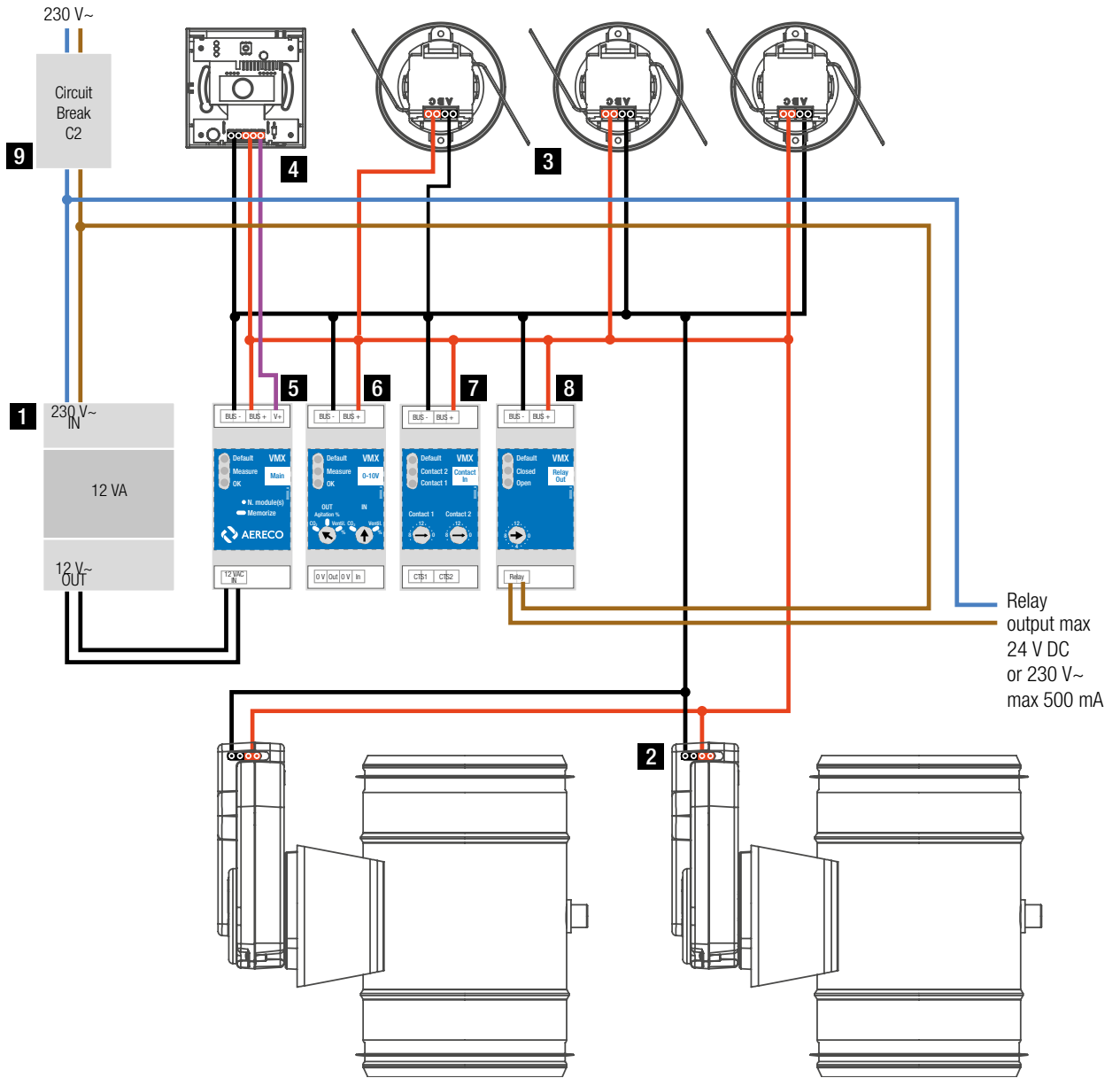

- 1** 230 V~ /12 V ~ (12 VA) Transformer
- 2** Motorised valves
- 3** VMX S-PRE Optical sensor(s)

- 4** VMX S-CO₂ CO₂ Sensor
- 5** VMX Main module
- 6** VMX IN/OUT 0-10 V module

- 7** VMX Contact IN module
- 8** VMX Relay Out module
- 9** C2 circuit breaker

Note : Each module contains 2 black terminals and 2 orange terminals to make wiring simpler and minimize the use of connector boxes.

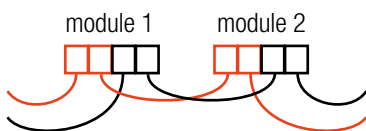

6. MOTORISED VALVES FOR THE VMX SYSTEM



Maximum 6 valves connected to a single ventilation unit (one ventilation unit = one MAIN module)

6.1. DESCRIPTION OF MOTORISED VALVES

The VMX system motorised valves are composed of a TROX valve (model VFC 125, VFC 160 or VFC 200), a **VMX Drive** and a **VMX VFT** adaptor plate.

Characteristics and functions of the VMX system motorised valves:

- used for exhaust only, supply only and balanced ventilation
- do not require a regulator module (function included on TROX VFC models)
- differential pressure range from 30 to 500 Pa
- flow tolerances approximately $\pm 10\%$ against a V_{nom} displayed on the curve
- valve connection with lip seal, corresponding to circular gains according to DIN EN 1506 or DIN EN 13180
- diameters : $\varnothing 125$, $\varnothing 160$ et $\varnothing 200$ mm. Also available in $\varnothing 80$, $\varnothing 100$ and $\varnothing 250$ mm, but only by special request.

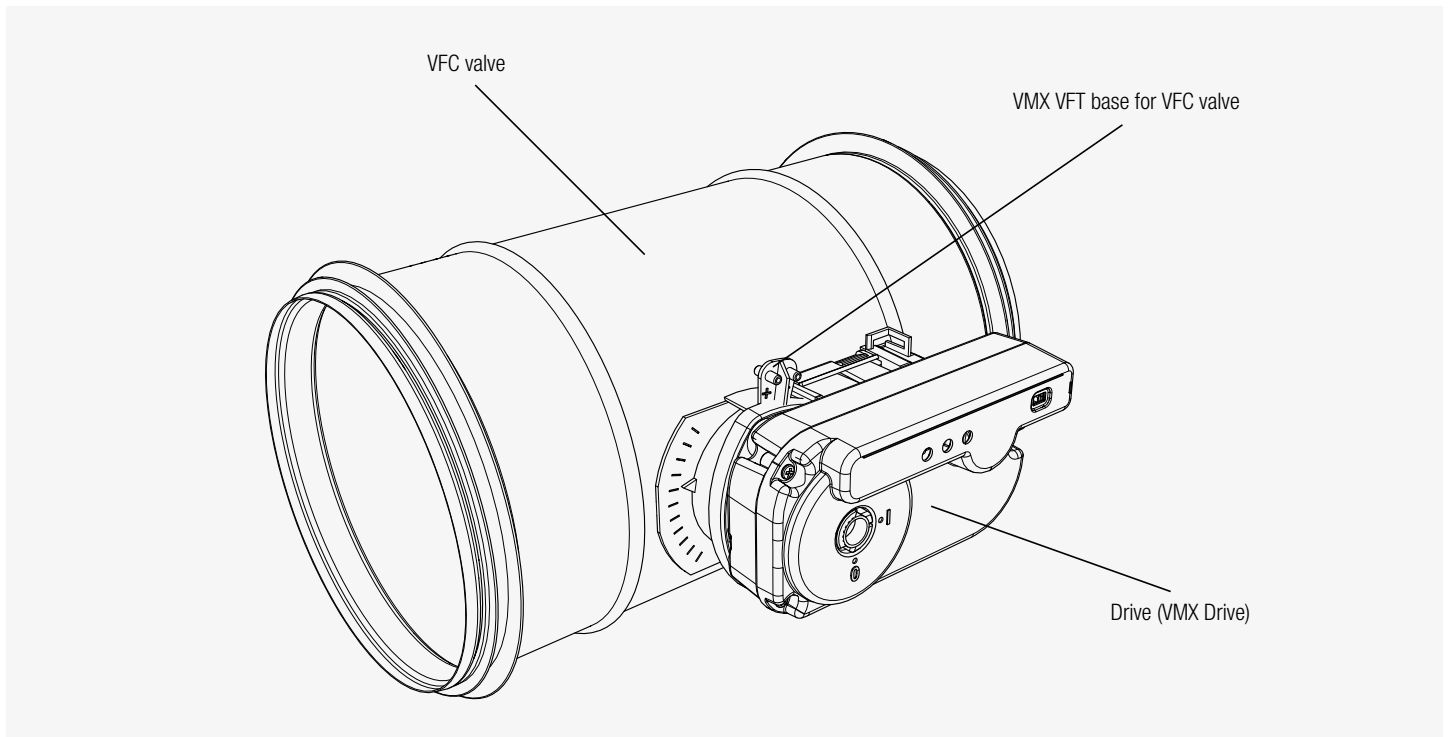

6.2. CHRONO-PROPORTIONAL FUNCTION

The VMX system motorised valves function on "full or none". This principle enables the ventilation of rooms at the nominal flow of the diffuser only, which guarantees a purging effect and optimal distribution of new air.

By managing opening times on full or none modulated in ten-minute cycles, this principle enables the achievement of a mean flow per cycle in proportion to the input parameters (level of CO_2 , presence, motion, etc.). This management mode is called the "Chrono-proportional mode".

In chrono- proportional mode:

- 10 % ventilation = 1 minute with ventilation + 9 minutes without ventilation
- 20 % ventilation = 2 minutes with ventilation + 8 minutes without ventilation
- 30 % ventilation = 3 minutes with ventilation + 7 minutes without ventilation
- etc.



In order to limit the intensity of the current circulating on the 2 bus wires, the valves open and close each one after the other.

6.3. ASSEMBLY

- Place each valve as far as possible from the diffuser to which it is connected (recommended minimum: three times the diameter) to limit noise transmission. A housing treated acoustically is recommended.
- The selection of the valve operating mode (airflow input or extraction) is made via a selector switch on the valve drive; this enables the main module to be informed of the number of valves connected in the airflow input mode and in the extraction mode.
- Valves of different diameters can be connected on the same main module. With double-flow airflow, install the same number of valves for supply as for exhaust.

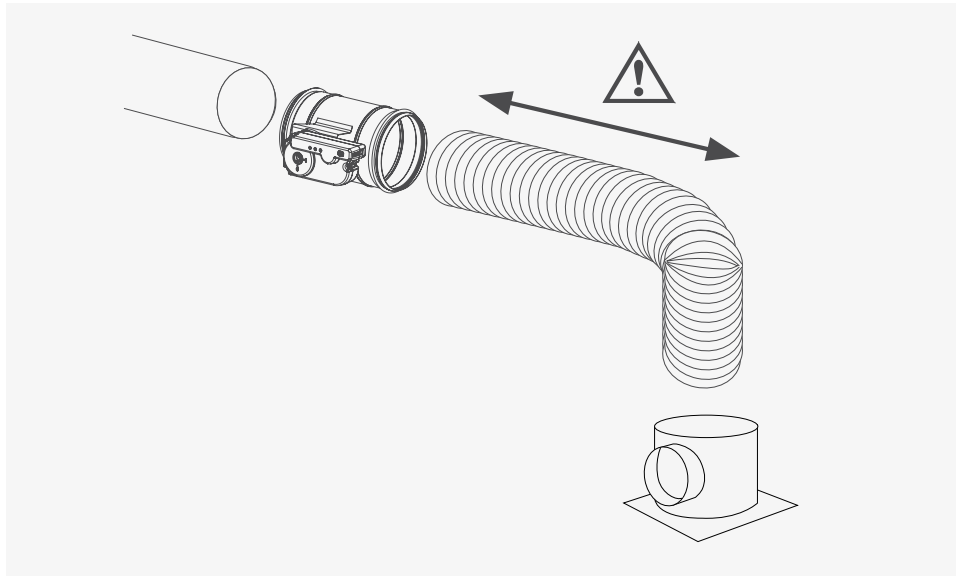

6.4. ASSEMBLY OF MOTORISED VALVES AND REGULATION OF NOMINAL FLOW

A motorised valve is composed of a VMX Drive and its plate (VMX VFT) mounted on a VFC TROX valve.

6.4.1. REGULATION OF NOMINAL FLOW

On each VFC valve, a characteristic flow curve is attached in order to determine the configurations on site. **The minimum flow should not be regulated to a value lower than position 3**, at the risk of seeing the airflow no more controlled. The holding pins supplied with the VMX VFT adaptor plate enable the valve opening to be held between position 0 and position n (**n must necessarily be between 3 and 10**). The flow in position n on the open valve is given on the characteristic flow curve placed on the valve (for example, if $n = 6$ then airflow = 210 m³/h on this valve model).

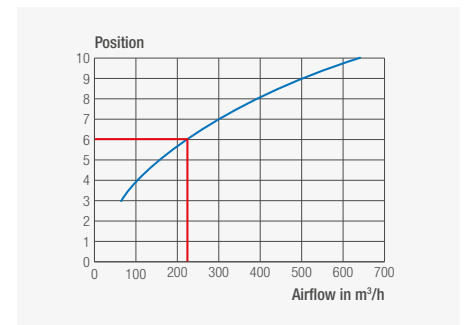

Configure the base for the VFR or VFC valve according to the desired nominal flow with the help of the spurs provided. The spurs should be sunk right in, without spaces.

Example (see the curve given in the example, in red): to achieve a nominal flow of 210 m³/h on this valve, add the necessary spurs required to block the shutter on position 6 as shown in the diagram below.

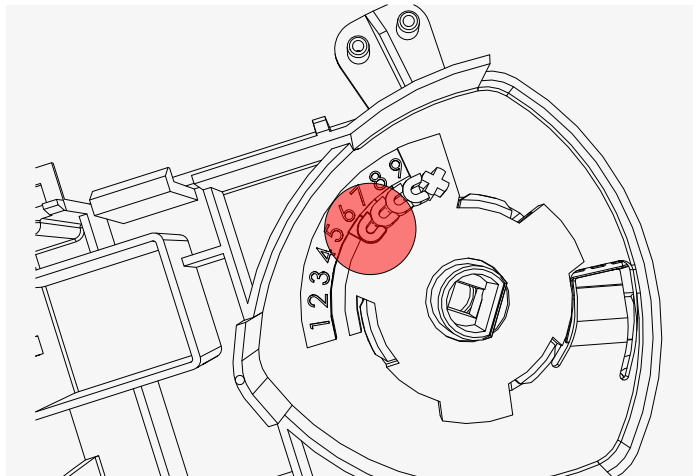
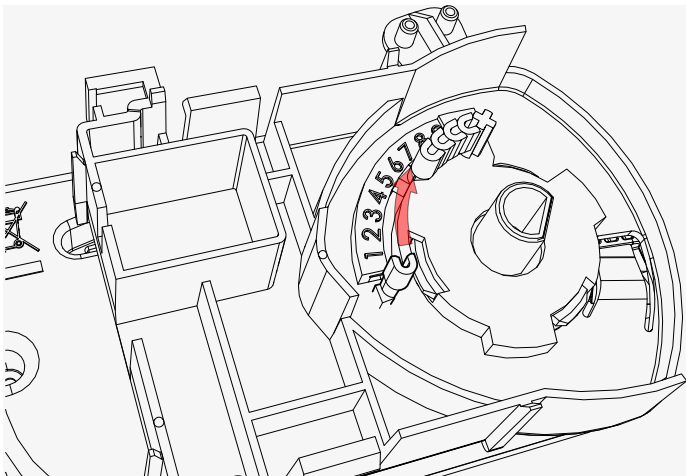

6.4.2. MOTORISED VALVE ASSEMBLY

1 Clip the base and axle of the drive transmission onto the valve

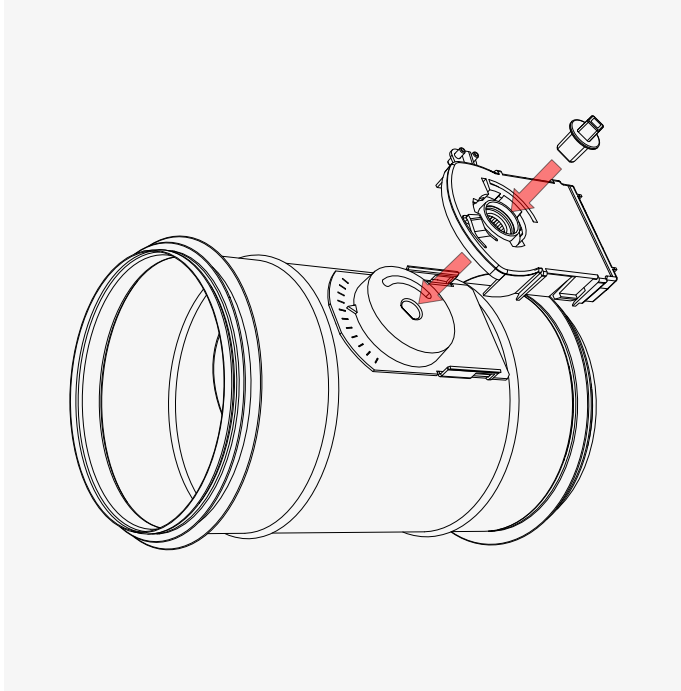

2 Open the shutter fully (shutter on the valve axle)

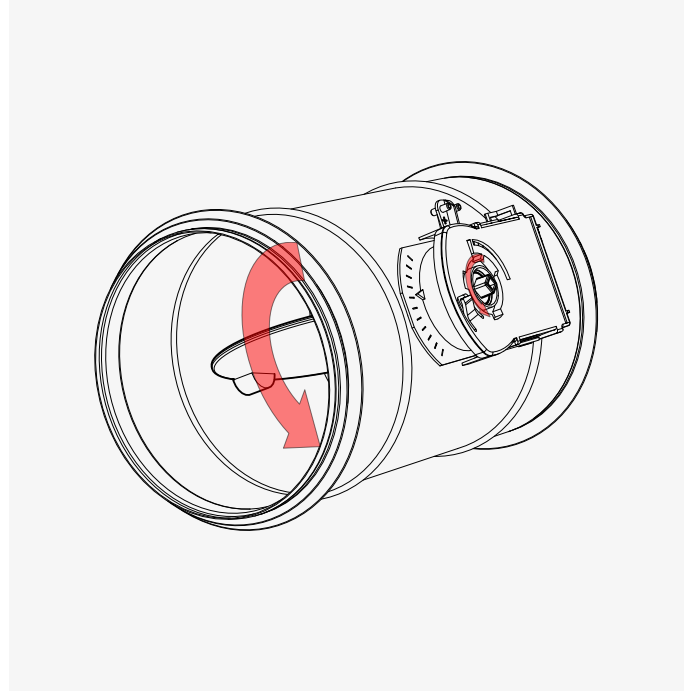

3 Clip the drive onto the base as per the diagram, then block the drive by turning it clockwise.

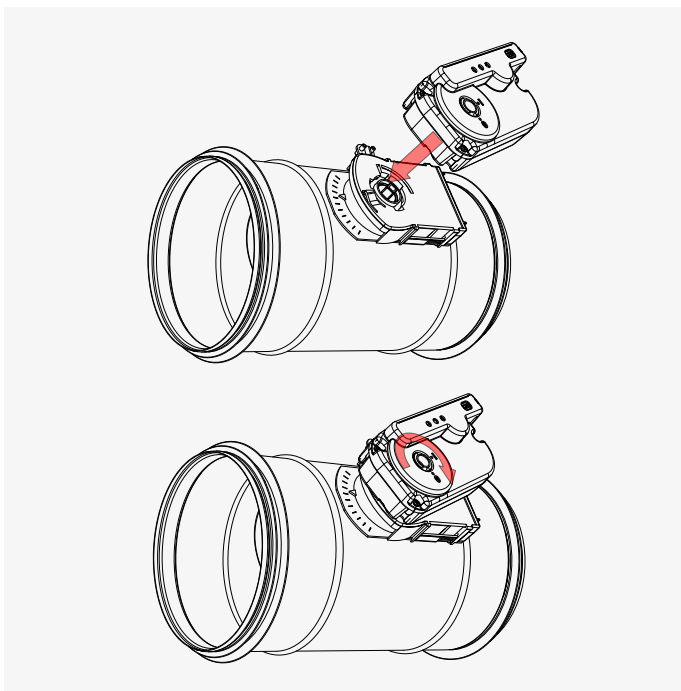

4 The valve is assembled, ready to be installed and connected.

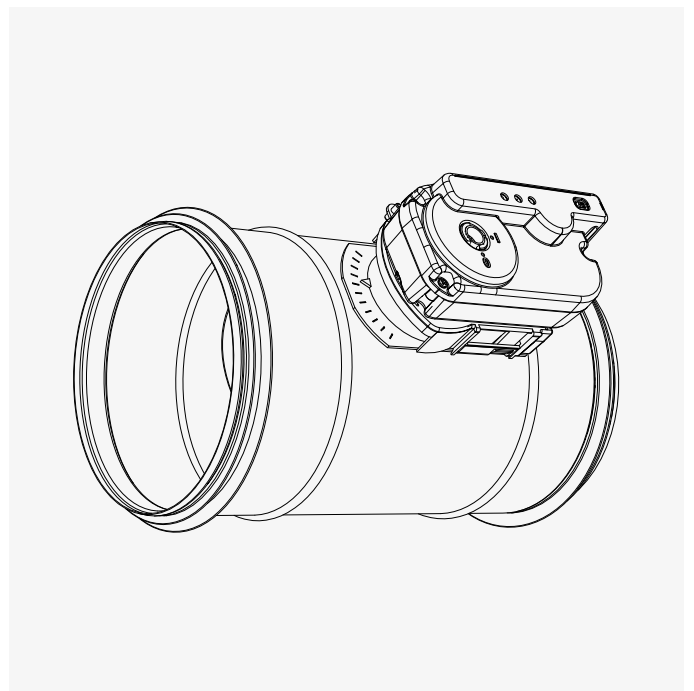

Valves

6.5. ELECTRICAL CONNECTION

- Power supply and transfer of information to the system via specific bus.
- The motorised valves are connected to the system by just two wires with a section of 1.5 or 2.5mm².
- **Maximum number of motorised valves per main module: 6**



When connecting the valves to the power supply the valves are closed one after the other and then open to initiate a first cycle of 1 to 10 mins at 100% ventilation.

6.6. SETTINGS

1 Regulation of the operating mode

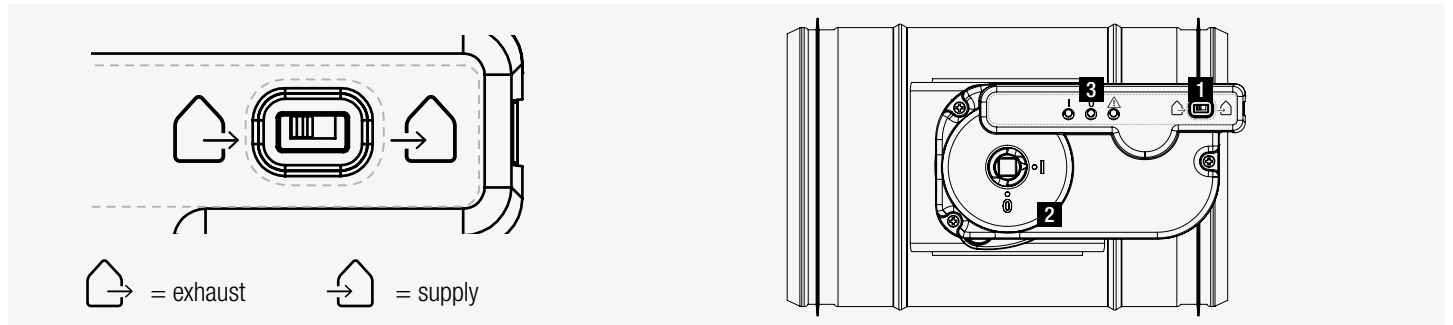

Adjust the valve operating mode (airflow extraction or input). This adjustment is made to each valve in the network with the help of the selector located on the VMX Drive.

The VMX system can be used for:

- supply only
- exhaust only
- balanced ventilation

For balanced ventilation, **the number of valves set for supply must equal the number of valves set for exhaust.**

2 Valve position indicators

- ⏏ = valve open
- ⊙ = valve closed

3 Interpretation of valve function indicators

BEHAVIOUR OF THE LEDS

INTERPRETATION	▼	▼	▼	▼	▼	▼
	valve open	valve closed	undefined position or being opened or closed	valve not configured	the operating mode has 1 been modified without a new memorisation in the main module	In balanced ventilation mode only The number of valves set for airflow supply is different from the number set for airflow exhaust

6.7. MAINTENANCE

The valves do not require any maintenance. Any failures which may occur are reported directly on the main module.

6.8. AIRFLOW NOISE TRANSMITTED IN THE DUCTWORK BY THE VALVES

Bruit du flux d'air																										
Nominal size of Valve Ø	V		$\Delta p_g = 100 \text{ Pa}$								$\Delta p_g = 200 \text{ Pa}$								$\Delta p_g = 500 \text{ Pa}$							
			L_w in dB								L_w in dB								L_w in dB							
			f_m in Hz								f_m in Hz								f_m in Hz							
	l/s	m³/h	63	125	250	500	1000	2000	4000	8000	63	125	250	500	1000	2000	4000	8000	63	125	250	500	1000	2000	4000	8000
80	6	22	57	42	39	36	34	28	24	25	58	46	44	42	41	36	35	37	60	52	50	49	50	45	49	53
	10	36	57	47	44	40	37	31	25	25	59	51	48	46	43	38	36	37	61	56	54	53	52	48	50	53
	20	72	58	52	50	45	40	34	26	25	59	57	54	51	47	42	37	37	61	62	60	58	56	51	51	53
	42	151	58	58	56	50	44	38	27	24	60	62	61	56	50	45	38	36	62	68	67	64	59	55	52	52
100	6	22	52	39	39	40	38	32	30	27	53	42	43	44	43	39	38	37	55	46	48	50	51	48	50	51
	15	54	55	48	46	44	41	35	31	28	56	51	50	48	47	42	39	38	58	55	55	54	54	51	51	52
	30	108	57	56	51	47	44	38	32	29	58	59	55	52	49	45	40	39	60	63	60	57	56	54	52	53
	65	234	60	64	56	51	46	41	33	30	61	67	60	55	52	48	41	40	63	71	65	61	59	57	53	54
125	10	36	47	34	32	33	30	24	22	21	49	37	36	38	36	32	34	51	42	42	45	44	43	46	50	
	20	72	51	43	40	39	35	30	26	24	53	47	44	44	41	38	36	37	56	52	49	50	50	49	50	54
	45	162	56	54	48	45	41	36	30	28	58	57	52	50	47	44	41	40	61	62	58	56	56	55	55	57
	100	360	61	64	57	51	47	42	35	31	63	68	61	56	53	51	45	44	66	73	66	62	62	62	59	61
160	18	65	47	41	38	38	34	30	28	28	49	44	42	43	41	38	37	38	52	48	47	50	50	49	50	52
	45	162	53	50	46	43	40	35	32	31	55	53	50	48	47	43	41	41	57	57	55	55	56	54	53	54
	85	306	57	57	51	47	44	38	34	33	59	60	55	52	51	47	43	43	61	64	60	59	60	58	56	56
	185	666	62	64	58	52	49	43	37	35	64	67	62	57	56	51	47	45	66	71	67	64	65	62	59	59
200	25	90	44	39	37	39	37	32	26	24	47	43	42	44	43	40	35	34	51	48	49	51	52	50	48	48
	60	216	51	48	44	43	41	38	31	27	53	51	49	48	47	46	41	38	57	56	55	55	56	56	54	52
	120	432	56	54	49	46	44	43	35	30	58	58	54	51	51	51	45	41	62	63	60	58	60	61	58	55
	250	900	61	61	54	49	48	48	39	34	64	65	59	55	55	56	49	44	67	70	66	62	63	66	62	58
250	37	133	46	37	39	43	40	36	31	27	48	41	43	47	46	43	40	37	52	45	50	53	55	53	52	52
	100	360	54	45	45	46	44	42	36	31	56	49	49	50	50	45	42	40	62	53	55	56	58	60	58	56
	185	666	59	50	48	48	46	46	39	34	61	53	53	52	52	54	48	45	65	58	59	58	60	64	61	59
	370	1332	64	55	53	50	48	51	42	37	67	59	57	55	55	58	52	48	70	64	63	61	63	68	64	63

6.9. NOISE RADIATED BY THE VALVES (PRODUCED IN THE FALSE CEILING)

Bruit du flux d'air																										
Nominal size of Valve Ø	V		$\Delta p_g = 100 \text{ Pa}$								$\Delta p_g = 200 \text{ Pa}$								$\Delta p_g = 500 \text{ Pa}$							
			L_{w2} in dB								L_{w2} in dB								L_{w2} in dB							
			f_m in Hz								f_m in Hz								f_m in Hz							
	l/s	m³/h	63	125	250	500	1000	2000	4000	8000	63	125	250	500	1000	2000	4000	8000	63	125	250	500	1000	2000	4000	8000
80	6	22	20	8	6	14	16	16	12	15	21	12	11	20	23	24	23	27	23	18	17	27	32	33	37	43
	10	36	20	13	11	18	19	19	13	15	22	17	15	24	25	26	24	27	24	22	21	31	34	36	38	43
	20	72	21	18	17	23	22	22	14	15	22	23	21	29	29	30	25	27	24	28	27	36	38	39	39	43
	42	151	21	24	23	28	26	26	15	14	23	28	28	34	32	33	26	26	25	34	34	42	41	43	40	42
100	6	22	17	7	8	19	21	20	18	17	18	10	12	23	26	27	26	27	20	14	17	29	34	36	38	41
	15	54	20	16	15	23	24	23	19	18	21	19	19	27	30	30	27	28	23	23	24	33	37	39	39	42
	30	108	22	24	20	26	27	26	20	19	23	27	24	31	32	33	28	29	25	31	29	36	39	42	40	43
	65	234	25	32	25	30	29	29	21	20	26	35	29	34	35	36	29	30	28	39	34	40	42	45	41	44
125	10	36	21	4	2	9	8	4	6	9	23	7	6	14	14	12	16	22	25	12	12	21	22	23	30	38
	20	72	25	13	10	15	13	10	10	12	27	17	14	20	19	18	20	25	30	22	19	26	28	29	34	42
	45	162	30	24	18	21	19	16	14	16	32	27	22	26	25	24	25	28	35	32	28	32	34	35	39	45
	100	360	35	34	27	27	25	22	19	19	37	38	31	32	31	31	29	32	40	43	36	38	40	42	43	49
160	18	65	22	18	18	20	24	21	19	24	24	21	22	25	31	29	28	34	27	25	27	32	40	40	41	48
	45	162	28	27	26	25	30	26	23	27	30	30	30	30	37	34	32	37	32	34	35	37	46	45	44	50
	85	306	32	34	31	29	34	29	25	29	34	37	35	34	41	38	34	39	36	41	40	41	50	49	47	52
	185	666	37	41	38	34	39	34	28	31	39	44	42	39	46	42	38	41	41	48	47	46	55	53	50	55
200	25	90	23	22	22	24	23	21	17	15	26	26	27	29	29	29	26	25	30	31	34	36	38	39	39	39
	60	216	30	31	29	28	27	27	22	18	32	34	34	33	33	35	32	29	36	39	40	40	42	45	45	43
	120	432	35	37	34	31	30	32	26	21	37	41	39	36	37	40	36	32	41	46	45	43	46	50	49	46
	250	900	40	44	39	34	34	37	30	25	43	48	44	40	41	45	40	35	46	53	51	47	49	55	53	49
250	37	133	27	22	25	29	27	25	22	18	29	26	29	33	33	32	31	28	33	30	36	39	42	42	43	43
	100	360	35	30	31	32	31	31	27	22	37	34	35	36	37	39	36	33	41	38	41	42	45	49	49	47
	185	666	40	35	34	34	33	35	30	25	42	38	39	38	39	43	39	36	46	43	45	44	47	53	52	50
	370	1332	45	40	39	36	35	40	33	28	48	44	43	41	42	47	43	39	51	49	49	47	50	57	55	54

7. MAIN MODULE (VMX MAIN)

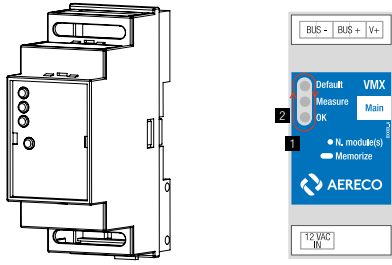

The modules are installed and configured in the following order. Each stage is detailed further down.

1. **Wire up the set of modules and sensors**
2. **Power up the system**
3. **Configure the settings for the modules and the CO₂ sensor**
4. **Once the start-up cycle is finished: memorise the system configuration (main module)**

7.1. FIELD OF APPLICATION

- VMX system (only)
- unizone and multizone application
- Indispensable for each ventilation unit operating in presence, motion or CO₂

7.2. DESCRIPTION

- The main module is the central element of the VMX system, and indispensable for its operation.
- Centralises all the bus information.
- The only powered element in the VMX system. It supplies power and information to all the other elements in the system.
- It has a mode selector button ("full or little", or proportional)
- It has a jumper to operate in "full or little" mode (100% - 10%) or "full or none" (100% - 0%)
- It indicates the number of modules connected to the system.
- It detects and signals failures and short circuits in the system.
- The main module must be accompanied by the transformer specified in this document.
- One single module connected to the power supply.
- Add a C2 circuit breaker before the power input.

7.3. DIMENSIONS

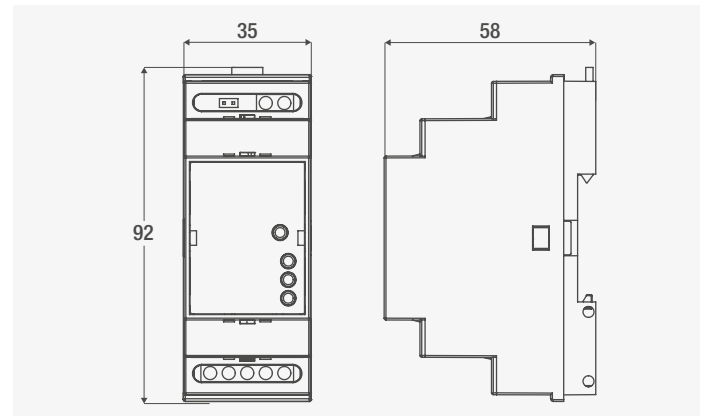

7.4. REDUCED FLOW MANAGEMENT

The minimum ventilation by default is never zero but equal to 10% of the maximum rate of ventilation attainable ("Full or little" mode). It is however possible regulate the module initially (before wiring) so that the minimum ventilation of the system is zero ("full or none" mode). In any event and before proceeding to release the blocks, always check that the set-up complies with the regulations in force for the premises in question. The release jumper can be repositioned subsequently at any moment. Memorisation at main module level will then be required.

Release jumper

- Jumper present: minimum ventilation is blocked at 10% of the maximum ("Full or little")
- Jumper not present: minimum ventilation reaches 0% ("full or none")

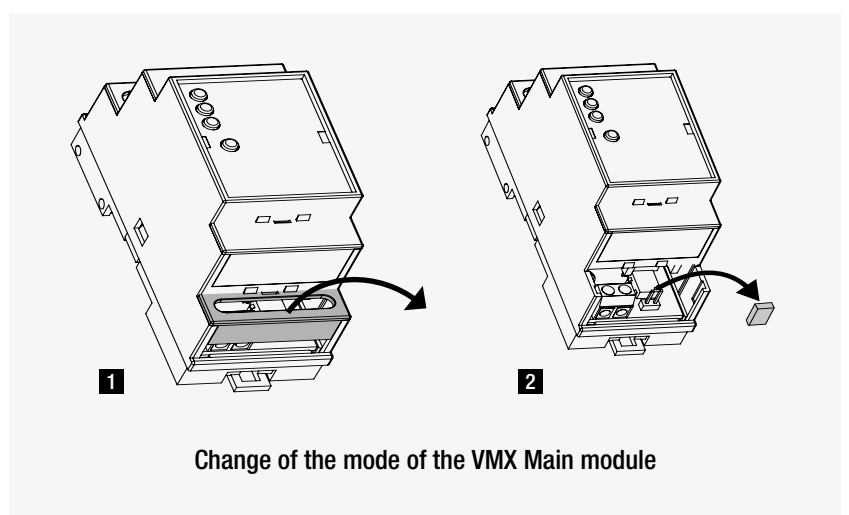

N.B. the release jumper can be subsequently repositioned at any moment. A new memorisation of the main module will then be required.

7.5. ASSEMBLY

- Install one main module per zone to be ventilated (one zone = one room)
- Mount the main module on a DIN rail in the power box
- Its width corresponds to two standard electrical modules

7.6. ELECTRICAL CONNECTION

Connect each module as indicated in the general wiring diagram. The modules were designed to be fixed on a DIN rail. They can be installed directly in a power cabinet or in a separate power box. The boxes used must comply with regulations in force and have an IP protection index in accordance with their place of installation.

12 VAC/12 VA "In" terminal powered by a 230 VAC - 12 VAC transformer. The main module should be connected to a power supply with appropriate EMC. The power supply indicated in this document is highly recommended, as it has valid EMC.



Each Main module should have its own circuit breaker and be connected directly to the electrical switchboard especially with a view to enabling maintenance operation.

A "Bus" terminal supplies power and information to all the other elements in the system.

Maximum number of elements per main module: 1 x VMX S-CO2 sensor, 8 x VMX S-PRE sensors, 1 x In/Out 0-10 V Module, 2 x Contact In Modules, 2 x Relay Out modules, 6 x motorised valves.

System electrical protection: Add a C2 circuit breaker upstream the power input.

In case of a power cut, the configuration is saved in the main module.

7.7. POWERING UP THE SYSTEM

Connect the main module to a 12 V~ power supply following the diagram in the chapter relative to the electrical installation of the system and then switch it on.

Characteristics of the transformer:

- Output voltage: 12 V~
- Power: 12 VA
- EN61558



To protect the circuit correctly, use one C2 circuit breaker and one transformer per main module.

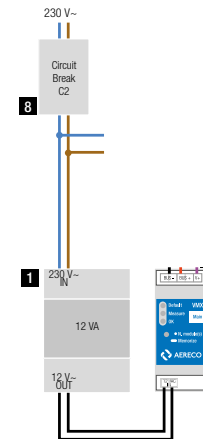

7.8. START-UP CYCLE

The flashing light indicates the launching of the start-up cycle. The flashing light can perform from one to five cycles.

Once the start-up cycle has been completed, you can proceed to configure the system at the main module level.

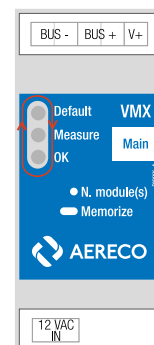

7.9. MODULES CONFIGURATION

Each module installed must be configured according to the instructions after to correspond to the desired functions. Once the system is powered up and the start-up cycle completed, memorisation is completed at the main module level. Each change of configuration or settings must be followed by a memorisation of the system via the "memorise" button on the main module. Each change of configuration (addition of an element) or settings (change of the position of a cursor on an element) not followed up by a memorisation will generate malfunctions in the system.

7.10. MEMORISING THE SYSTEM SETTINGS

After the start-up

1 Memorisation button

- Configuration in the proportional mode: press for between 5 and 10 seconds (yellow display "Measure" flashes quickly).
- Configuration in the "Full or Little" mode: press for more than 10 seconds (yellow display "Measure" flashes slowly).
- Recording of the number of components (except the main module) memorised. It only functions once it is configured: press for less than 2 seconds. The LED flashes as many times as there are elements connected to the VMX Main module.

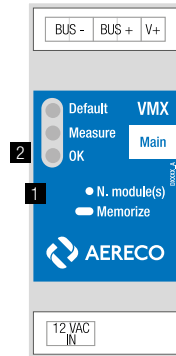

Press on the memorise button:

- between 0 and 5 seconds, steady display of "Measure" LED
- between 5 and 10 seconds, "Measure" LED flashes, release it during this time to pass to chrono-proportional mode
- between 10 and 15 seconds "Measure" LED display steady, release during this time to pass to "full or little" mode (if jumper is present) or "full or none" (if jumper is removed).

After each start-up the system closes the valves in order to find the 0. After each system memorisation, the system closes the valves again then starts a 100% ventilation cycle before, where necessary, decreasing the ventilation rate progressively to the target rate (-10% maximum per 10-minute step).

2 Interpretation of the signals

BEHAVIOUR OF THE LEDS

	Default	Mode	OK	Red (fast)	Red (alternating or synchronised)	Red (solid)	Red (fast)	Red (sequence)
Default	○	○	○	● (fast)	● (alternating or synchronised)	●	● (fast)	● (sequence)
Mode	○	● (flashes)	○	● (fast)	● (alternating or synchronised)	○	○	○
OK	● (flashes)	● (flashes)	○	● (fast)	○	○	○	○
INTERPRETATION	operation in mode 10 %-100 % (minimum flow not zero)	operation in mode 0 %-100 % (minimum flow not zero)	memorisation taking place	return to factory set-up	wiring problem	system not configured	change of configuration without new memorisation of the main module	fault (see codes below)

Fault codes	Code displayed on:	Meaning
2 x ●	main module	a module or a sensor is missing
4 x ●	main module and malfunctioning module / sensor	a module or a sensor is not working correctly
6 x ●	main module	too many modules / sensors connected
8 x ●	main module and valves	(in balanced ventilation only) The number of valves set for input mode is different from the number of valves set for extraction mode

Return to factory configuration (only in the case of malfunction)

- turn off the system (circuit breaker)
- turn the system back on (circuit breaker) by pressing the memorisation button on the main module until the LEDs start flashing.

Performance measurements on starting up the system

Measurement is taken with all the valves open. For this, count up to 10 minutes after the end of the configuration cycle, the cut off the power from the main module (circuit breaker): the valves will then remain in the open position. Once the measurement is finished, power up the system again.

7.11. MAINTENANCE

The valves do not require any maintenance. Any failures which may occur are reported directly on the main module.

7.12. POWER SUPPLY / TRANSFORMER

Description :

- 230 VAC / 12 VAC - 12 VA transformer
- Fuse included = T100L 250V
- powers the main module

Assembly :

- install one main module per transformer
- designed to be mounted on the DIN rail in a power box (width corresponding to four electrical modules)

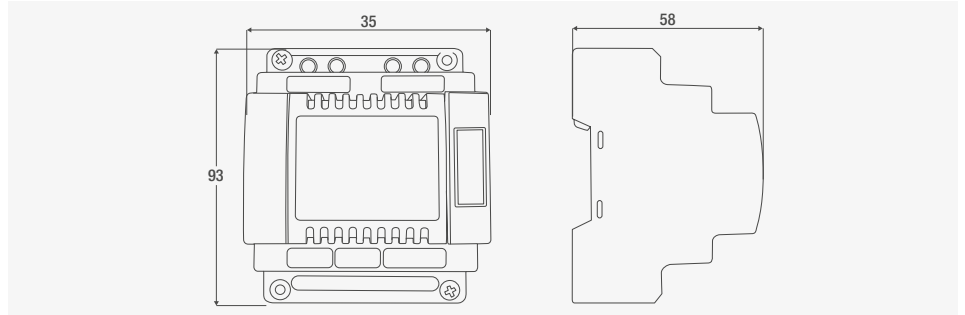

This transformer ensures a 12 VAC electrical power supply to the main module. It also enables the filtering of interference on the secondary module in order to preserve the primary. For this reason, it is essential to connect each module to an individual transformer (never connect more than one main module to the same transformer).

8. VMX S-PRE OPTICAL SENSOR

8.1. FIELD OF APPLICATION

- VMX system
- Unizone application (at fan level) and multizone application (at the level of several motorised valves)
- Presence or motion type detection

8.2. DESCRIPTION

Any movement made in the zone is detected by the optical sensor (by infra-red radiation) which sends electrical impulses (0-1) to the main module for the information to be processed.

The VMX S-PRE optical sensor is composed of:

- a Fresnel lens with 31 pairs of facets which concentrate the radiation produced by a person on the pyro-electric sensors and divides the field of detection into 62 zones.
- specific pyro-electric sensors which gather the infra-red radiation produced by a person and enable the measurement of the number of movements via the facets of the Fresnel lens.

It has a LED, which displays the detections.

8.3. DIMENSIONS

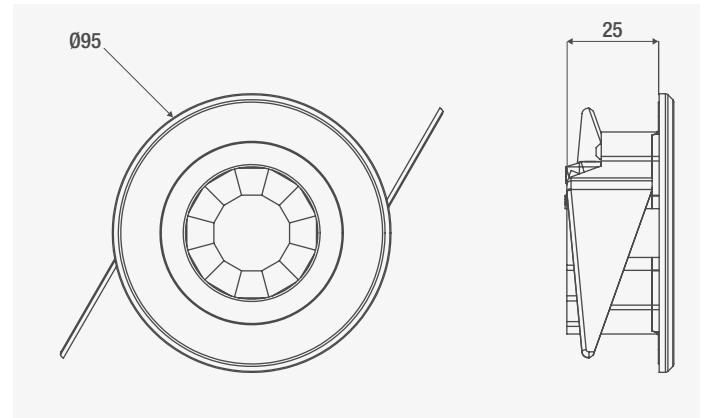

8.4. ASSEMBLY

The sensors are set in a D62 to D70 mm hole. They are equipped with claws to be placed in the false ceiling.

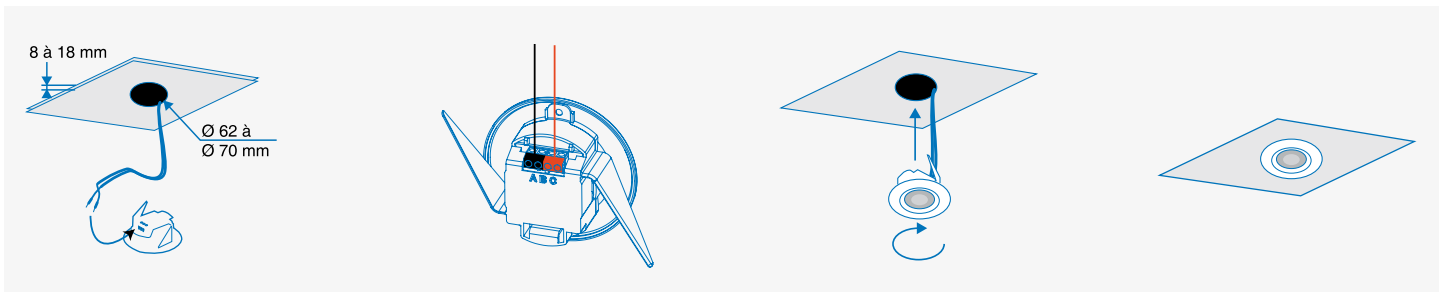

Placing the sensors

- Ceiling position
- detection zone = zone situated 1m from the partitions (the so-called "dead" zone, where there is little movement)
- installation height in ceiling position: between 2.5m and 3.5m.

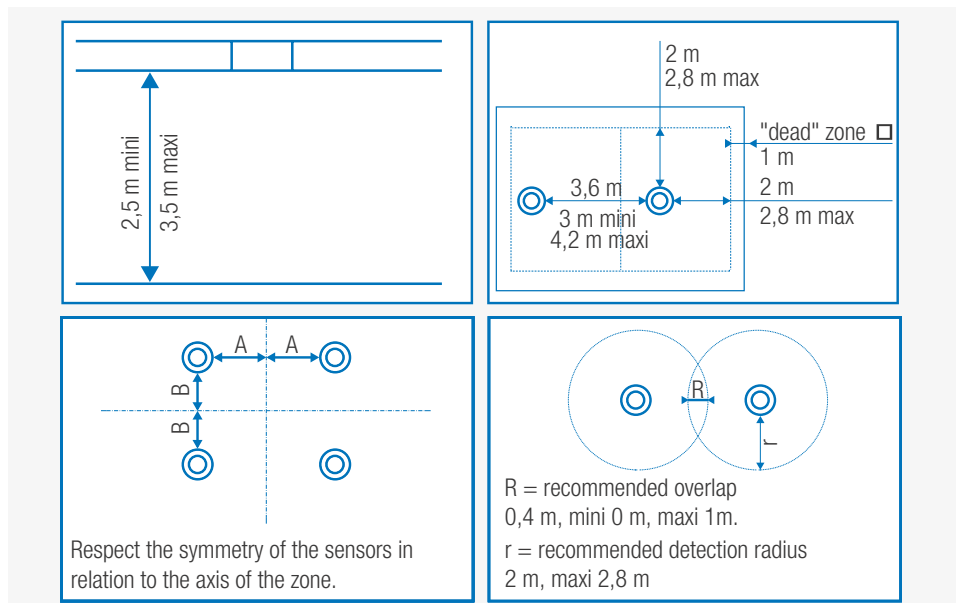

8.5. ELECTRICAL CONNECTION

- power supply and transfer of information to the VMX system via specific bus
- the optical sensor is connected to the system by just two wires with a section of 1.5 or 2.5mm²
- maximum number of VMX S-PRE sensors per main module: 8

8.6. WIRING



Maximum 8 sensors connected per ventilation unit (=one Main module).

1. Connect the orange wire to the orange terminal, the black wire to the black terminal.
2. Install the sensor in the false ceiling following the instructions given before (overlap, distance, etc.).
3. Connect the wires according to the electrical diagram provided in this document.

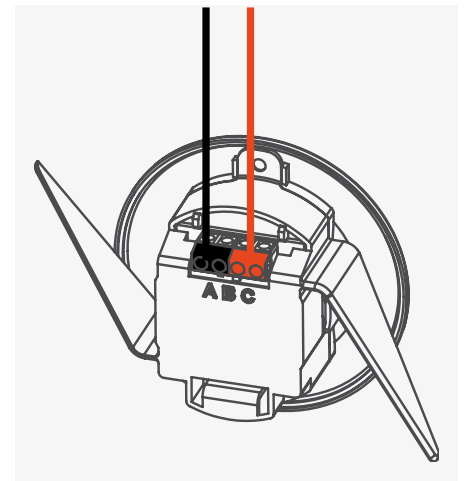

8.7. INTERPRETATION OF SIGNALS

A LED under the lens lights up with each movement detected, and also in the following cases:

BEHAVIOUR OF THE LEDS

	● (permanent)	● (initial)	☀ (sequence)
INTERPRETATION	▼ module(s) not configured	▼ normal mode	▼ breakdown

8.8. OPERATING MODES

The "full or little" mode (if the jumper is present on the main module) or the "full or none" mode (if the jumper is pulled out on the main module) is obtained by pressing the "memory" button on the main module for between 10 and 15 seconds :

- "full or little" operation according to the movements detected
- processing information by a single module
- modulation of airflow by a motorised valve (multizone) or by acting on the fan speed (unizone).

% ventilation flow

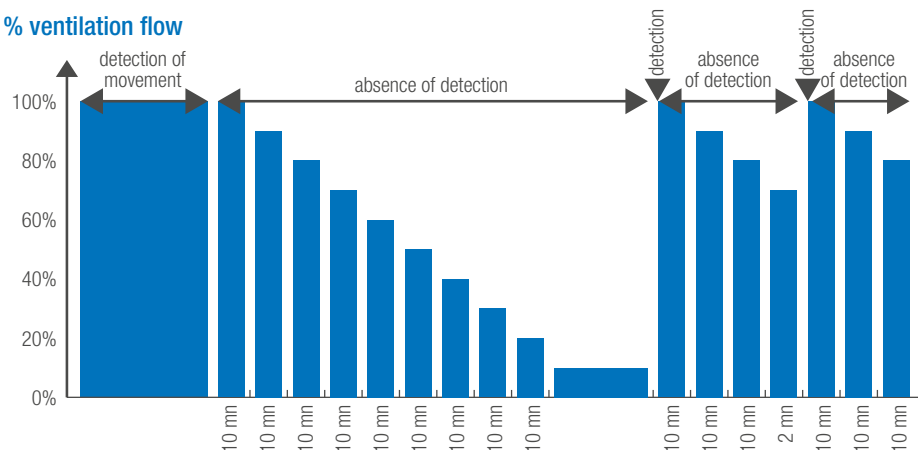

The ventilation flow diminishes every 10 mins in steps of 10% as shown in the graph opposite, returning to 100% when a movement is detected.

The "chrono-proportional" mode is obtained by pressing on the "memorise" button on the main module for between 5 and 10 seconds:

- operation in proportion to the occupation activity measured
- detection of occupation by the optical sensors according to the number of movements detected
- processing information by a single module
- modulation of airflow by a motorised valve (multizone) or by acting on the fan speed (unizone).

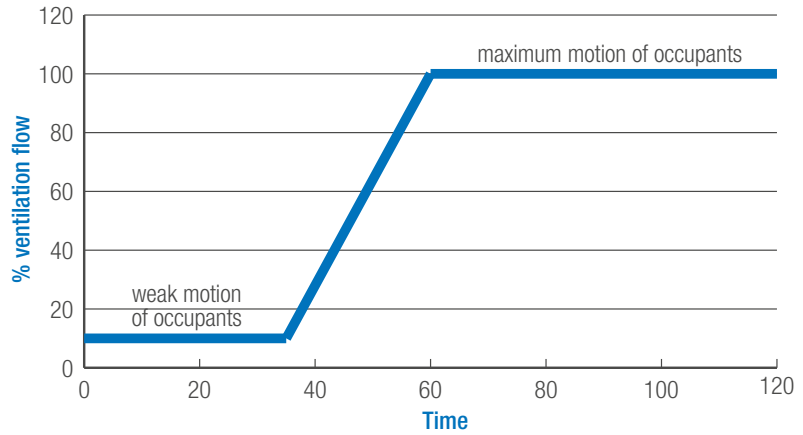

The ventilation flow varies according to motion, proportionally between 0% or 10% and 100%. Just as for the "full or little" mode, the flow diminishes every 10 mins a maximum of 10% (in order to ventilate the premises sufficiently after all the occupants have left). But where necessary it can increase by $n \times 10\%$ in the following cycle, according to requirements.

8.9. MAINTENANCE

No specific maintenance is required.

9. VMX S-CO2 CO₂ DETECTOR

9.1. FIELD OF APPLICATION

- VMX system
- Unizone application (at fan level) and multizone application (at the level of several motorised valves)
- CO₂ detection

9.2. DESCRIPTION

CO₂ sensors enable the measurement of concentrations of CO₂ in a room. The principle of the analysis consists of measuring the absorption of infra-red rays so as to establish concentration in the room. This method gives a very accurate response and it is independent of all other types of pollution (such as humidity, dust accumulation, etc.). In the "full or little" operating mode the CO₂ threshold can be regulated via a button on the sensor box (from 700 ppm to 1,700 ppm per 200 ppm steps).

9.3. DIMENSIONS

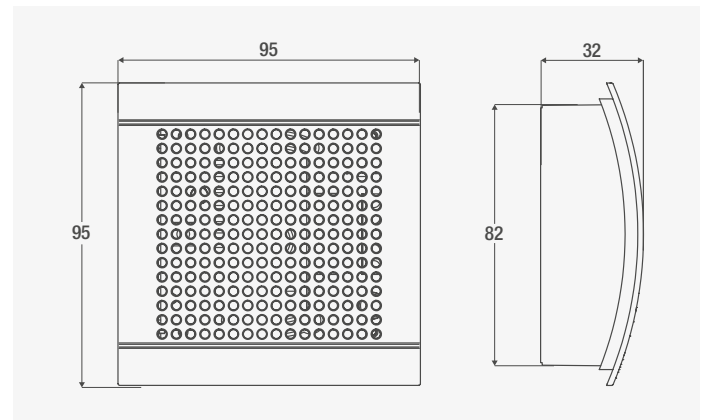

Range of measurement	0 to 2 000 ppm
Electrical power supply	VMX system
Output signal (proportional to the Measured ambient concentration)	bus VMX
Consumption	< 3 W
Electrical protection	IP 20
Test results	
Response time	6 min 55 s
Overflow coefficient	1,025
Deviation at 1,100 ppm	26,57 ppm

9.4. ASSEMBLY

Les détecteurs peuvent être fixés avec deux vis.

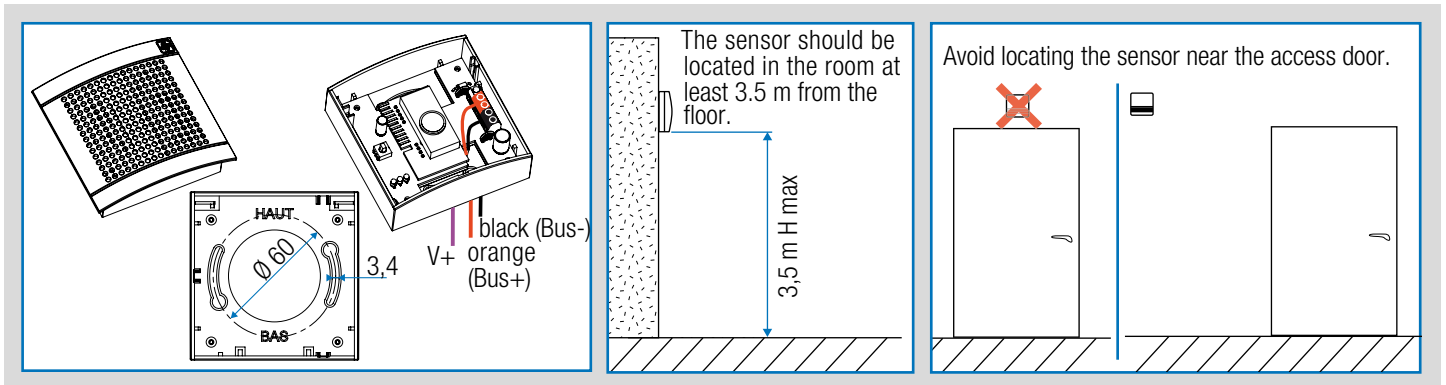

- ceiling or wall position
- detection zone = zone situated 1 metre from the partitions (the so-called "dead" zone, where there is little movement)
- installation height in ceiling position: between 2.5m and 3.5m.

9.5. ELECTRICAL CONNECTION

- power supply and transfer of information via VMX specific bus
- the sensor is connected to the system by just 3 wires with a section of 1.5 or 2.5mm²
- **Maximum number of CO₂ sensors per main module: 1**

9.6. WIRING



Maximum 1 CO₂ sensor connected per ventilation unit.

1. Carefully remove the cover of the CO₂ sensor.

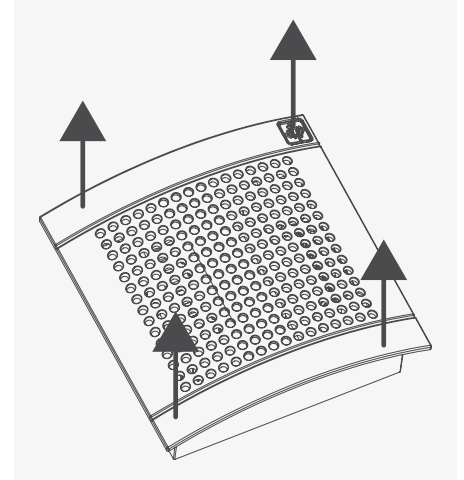

2. Connect the orange wire to the orange terminal, the black wire to the black terminal.

Connect the V+ terminal on the CO₂ sensor to the V+ terminal on the main module. If necessary unclip the electrical circuit.

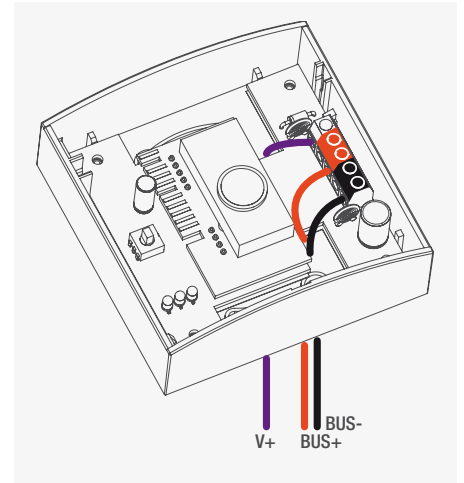

3. Regulate the trip threshold.

Position / Selection	CO ₂ threshold by tripping ("full or little" mode) (+0/-100 ppm)
0-1	700
2-4	900
5-7	1 100 (default)
8-10	1 300
11-13	1 500
14-15	1 700



Recommended regulation value = 1 100 ppm

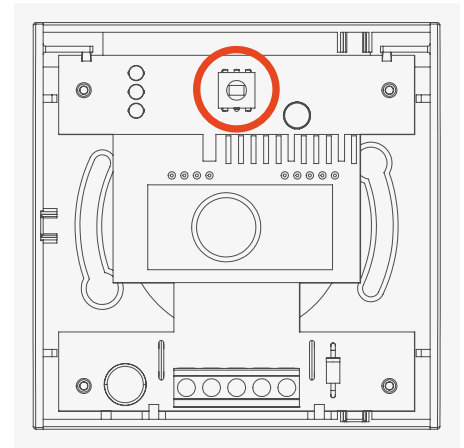

4. Install the sensor on the ceiling or on the wall, in a place where the level of CO₂ can be detected in accordance with the instructions for installations detailed before (position).

5. Connect the wires according to the electrical diagram of the system provided in this document.

9.7. INTERPRETATION OF SENSOR SIGNALS

BEHAVIOUR OF THE LEDS

	○	○	○	●	⦿ (fast)	⦿ (sequence)
● red LED	○	○	○	●	⦿ (fast)	⦿ (sequence)
● orange LED	○	⦿ (flashes)	⦿ } 1 flash	○	○	○
● green LED	⦿ (flashes)	○	⦿ } 1 flash	○	○	○
INTERPRÉTATION	level of CO ₂ ≤ threshold	level of CO ₂ > threshold	measures every 10 s	not configured	modification of threshold without memorisation of main module	breakdown

9.8. OPERATING MODES

The "full or little" mode (if the jumper is present on the main module) or the "full or none" mode (if the jumper is pulled out on the main module) is obtained by pressing the "memory" button on the main module for between 10 and 15 seconds.

- "full or little" operation according to CO₂ threshold
- processing information by a single module
- modulation of airflow by controlling a motorised valve (multizone) or by acting on the fan speed (unizone).

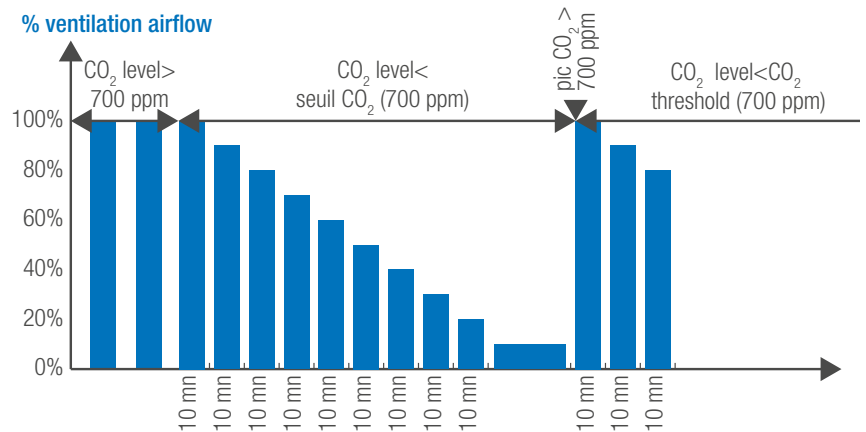

Operation in the "full or little" mode, for example with a CO₂ threshold regulation at 700 ppm

The "chrono-proportional" mode is obtained by pressing the "memory" button on the main module for between 5 and 10 seconds.

- Level of CO₂ < 700 ppm => minimum ventilation (0% with no jumper on main module, 10% with jumper on main module)
- Level of CO₂ between [700 ppm ; 1,100 ppm => ventilation % included in the interval [minimum ventilation ; 100%]
- Level of CO₂ > 1,100 ppm => maximum ventilation at 100%

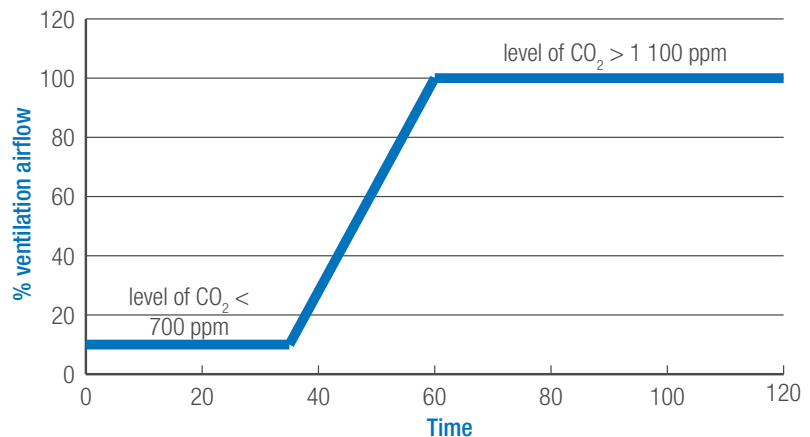

Just as for the "full or little" mode, the flow diminishes every 10 mins a maximum of 10% (in order to ventilate the premises sufficiently after all the occupants have left). But where necessary it can increase by $n \times 10\%$ in the following cycle, according to requirements.

And in a more general way:

“Full or little” mode (press start-up between 10 and 15 s) :
 SCO_2 = set value according to the cursor of the CO_2 sensor = CO_2
 (SCO_2 = 700 ppm (0-1) 900 ppm (2-4)... 1 700 ppm (14-15))

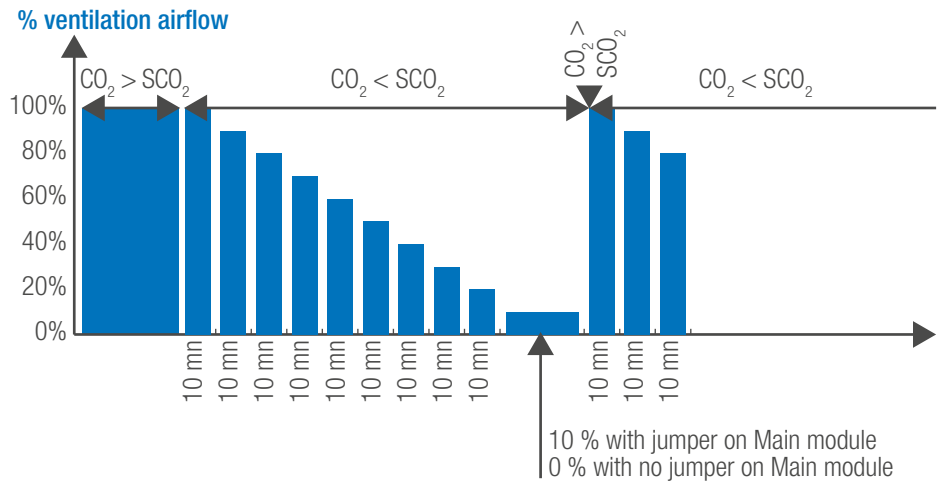

VMX S-PRE Detector

Proportional Mode:

(press start-up between 5 and 10 secs):

The average over the 10 mins should be greater than 1,100 ppm to be at 100% for the following 10 mins.

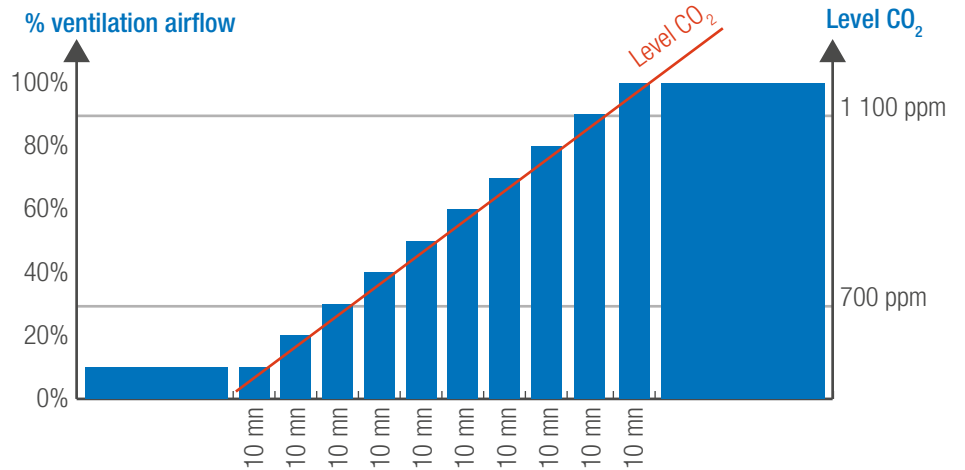

9.9. MAINTENANCE

Taking into account the slow circulation speed at the level of sensitive elements, the measurement of CO_2 is not affected by dust or water vapour. The sensor does not require recalibration during its life cycle. It has two infra-red sources with different operating cycles, which enables it to be recalibrated automatically.

10. VMX RELAY OUT MODULE

Offered as an option, the VMX Relay OUT module enables information to be communicated outside the system (status display, for example).

10.1. FIELD OF APPLICATION

- VMX system
- unizone and multizone application
- Presence or motion or CO₂ type detection

10.2. DESCRIPTION

VMX Relay OUT module transmits the status of an element in the system. It is a contact which is normally open but which closes when an event is detected.

Parameters for the triggering event can be configured (via the selector located on the module) from amongst:

- signalling breakdown(s) in the system,
- signalling the correct functioning of the system,
- rate of ventilation (selection x minutes in units of 10 minutes),
- signalling a presence (time out 5 minutes),
- signalling a presence (time out 20 minutes),
- select when surpassing the CO₂ threshold (+0/-100 ppm), parameter on the VMX S-CO₂ sensor,
- select when there is a peak flow demand,
- select when there is a minimum flow demand.

The Relay OUT module allows selection up to 500 mA under 24 VDC or 230 VAC.

Examples of applications: to light up a lamp the moment a presence is detected, to activate an indicator to signal a breakdown in the system, etc.

The Relay OUT module is equipped with LEDs which indicate that it is operating and warn in case of a breakdown in this module.

10.3. DIMENSIONS

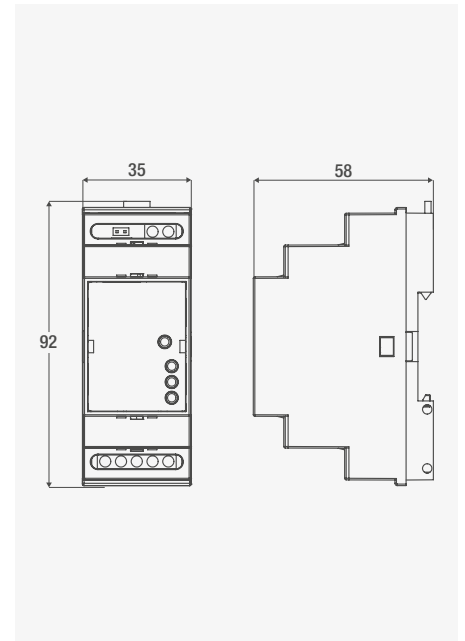

10.4. SETTINGS

To configure the module

1 Event selector switches

The revolving selector enables the selection of the event which will trigger a closed contact:

- 0-1 : signalling breakdown(s) in the unit
- 2-3 : signalling the correct functioning of the unit
- 4-5 : rate of ventilation (selection x minutes / 10)
- 6-7 : signalling a presence (time out 5 minutes)
- 8-9 : signalling a presence (time out 20 minutes)
- 10-11 : select when surpassing the CO₂ threshold (+0/-100 ppm)
- 12-13 : select when there is a peak flow demand
- 14-15 : select when there is a minimum flow demand

2 Interpretation of sensor signals

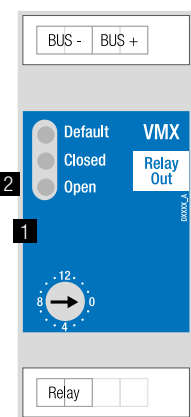

BEHAVIOUR OF THE LEDS

	Default	Closed	Open	Relay	Relay
	○	○	○	●	● (fast)
	○	● (flashes)	○	○	○
	● (flashes)	● (flashes)	○	○	○
INTERPRETATION	open	closed	system not configured	configuration change without new memorisation of main module	a module or a sensor is not working correctly

Examples :

- In position 10-11, if the CO₂ sensor cursor is in position 2, 3 or 4 (CO₂ threshold = 900 ppm), the relay closes if the level of CO₂ > 900 ppm, and opens if the level of CO₂ < 900 ppm.
- In position 12 or 13, the relay of the Relay OUT module closes if a peak flow instruction is activated..

10.5. ASSEMBLY

It is designed to be mounted on a power box DIN rail. Its width corresponds to two standard electrical modules.

10.6. ELECTRICAL CONNECTION

Connect the module according to the wiring diagrams provided in this document.

Bus Terminal:

- it receives electrical power and exchanges information with all the other elements in the system.
- connected to the bus by two wires with section 1.5 or 2.5 mm² (flexible or rigid)
- maximum number of Relay OUT modules per main module: 2

Relay Terminal:

- external communication (lighting up a lamp, etc)

11. VMX CONTACT IN MODULE

The VMX Contact IN module enables instructions from outside the system to be taken into account for them to be executed instantaneously.

11.1. FIELD OF APPLICATION

- VMX system
- Unizone and multizone application
- Motion, presence or CO₂ detection

11.3. DIMENSIONS

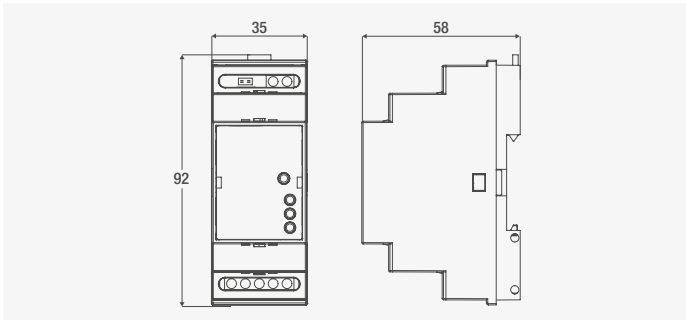

11.2. DESCRIPTION

The Contact IN module receives external information. Each Contact IN module has two dry contact inputs. The event will be triggered when the contact closes (Examples: closing a switch, pressing on a push button). If two events contradict each other, the last contact closed will have priority over the preceding one.

The following triggering events can be chosen via two selectors (one per input) on the front:

- Maximum forced ventilation
- Minimum forced ventilation
- Forced ventilation turned off

Examples of applications: cutting off ventilation when windows are opened, turning off the ventilation at night (clock), manually forcing ventilation to the maximum (switches), etc.

The Contact IN module is equipped with LEDs which indicate that it is operating and warn in case of a breakdown in this module.

11.4. SETTINGS

Configuring the module

1 Forced event selector switches

Note: the two inputs can be configured independently (one selector per event)

Position of the selectors:

- 0-1 : ventilation OFF (no flow)
- 2-3 : minimum ventilation (0 without jumper on VMX Main module, 10% with jumper)
- 4-5 : maximum ventilation
- 6-15 : positions not used

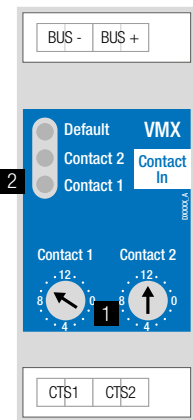

2 Interpretation of sensor signals

BEHAVIOUR OF THE LEDS

	Default	Contact 2	Contact 1	Default	Contact 2	Contact 1	Change of configuration	Module or sensor error
LED STATE	○	○	○	○	●	○	● (fast)	● (x4)
INTERPRETATION	Contact 1 open	Contact 1 closed	Contact 2 open	Contact 2 closed	not configured	change of configuration without new memorisation of the main module	a module or a sensor is not working correctly	

Examples :

- If the Contact 1 cursor is in position 0 or 1 and the electrical circuit connected to the CTS1 terminals is closed (push button pressed or switch turned off) then the instruction to cut ventilation off is sent: the VMX system cuts the ventilation off in the room immediately. If necessary, ventilation returns 10 minutes after the electrical circuit connected to the CTS1 terminal has been opened.

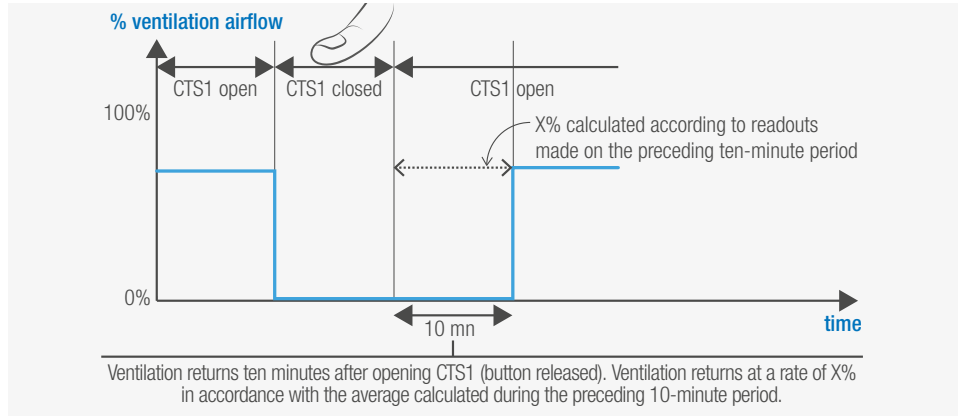
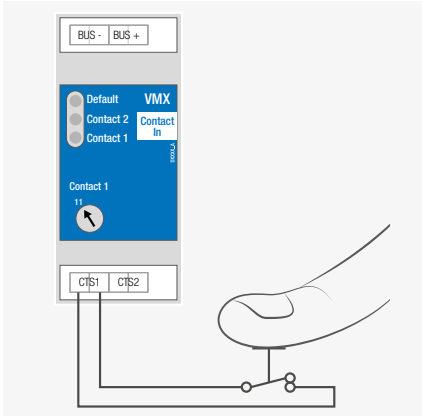

Instructions sent via a Contact IN module take priority and are immediate. **So this module can be used by an installer to test the installation.**

- If the Contact 2 cursor is in position 4 or 5 and the electrical circuit connected to the CTS2 terminals is closed (push button pressed or switch turned off) then the order to ventilate at 100% is given: The VMX system gradually returns to a target ventilation rate (via sensor or other means) 10 minutes after the electrical circuit connected to the CTS2 terminals has once again been opened.

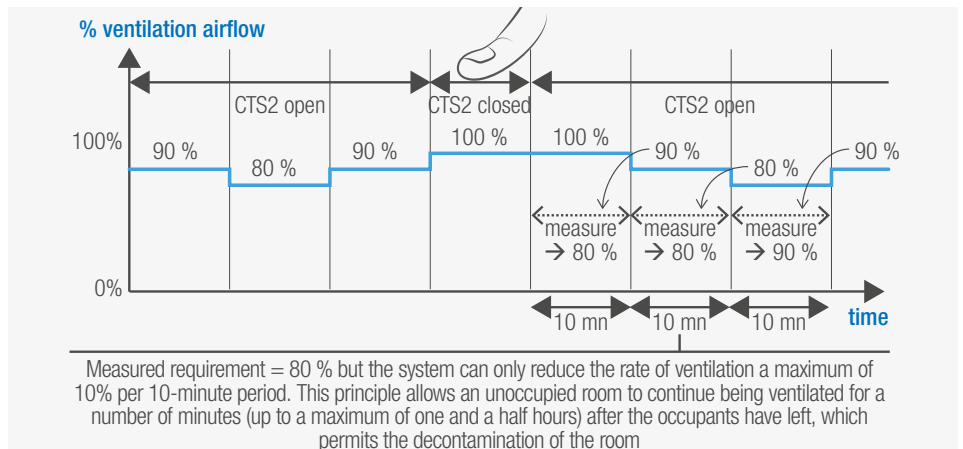
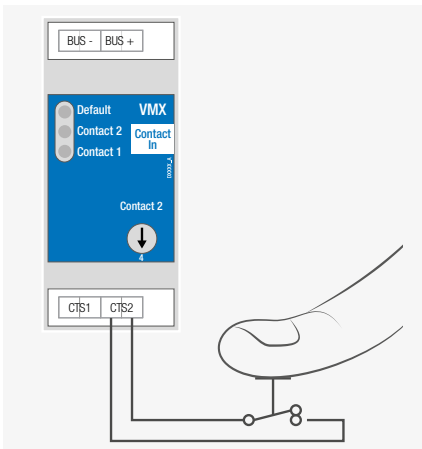

11.5. ASSEMBLY

It is designed to be mounted on a power box DIN rail. Its width corresponds to two standard electrical modules.

11.6. ELECTRICAL CONNECTION

Connect the module according to the wiring diagrams provided in this document.

Bus Terminal:

- it receives electrical power and exchanges information with all the other elements in the system.
- connected to the bus by two wires with section 1.5 or 2.5 mm² (flexible or rigid)
- **maximum number of Contact IN modules per main module: 2**

CTS1, CTS2 Terminal:

- receives external information to start up or shut down ventilation immediately.

12. VMX IN/OUT 0-10 V MODULE

The VMX IN/OUT 0-10 V module enables analogical information on the status of the system to be communicated and to take analogical instructions into account in order to execute or process them instantaneously.

12.1. FIELD OF APPLICATION

- VMX system
- Unizone and multizone application
- Motion, presence or CO₂ detection

12.2. DIMENSIONS

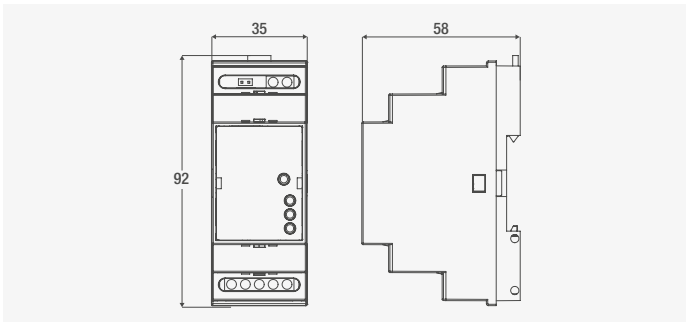

12.3. DESCRIPTION

The IN/OUT 0-10 V module receives and/or transmits a value of from 0 to 10 V from and/or to outside the system.

This value is proportional to a parameter (chosen via the selectors located on the module) for one of the following levels:

- CO₂ (0-10 V corresponds to 0-2,000 ppm)
- Motion (0-10 V corresponds to a 0-100% ventilation level)
- Ventilation (0-10 V corresponds to a 0-100% ventilation level)

The output voltage is 0-10 V under a maximum of 20 mA. Examples of applications: to give information to a BMS on the level of CO₂ in ppm, to receive instructions for ventilation from a BMS, etc. This module can be used to communicate with the drives in a unizone and multizone VMX installation. The IN/OUT 0-10 V module is equipped with LEDs which indicate that it is operating and warn in case of a breakdown in this module.

12.4. SETTINGS

Configuring the module

1 INPUT

Regulate the IN voltage input (0-10V):

- CO₂ : a CO₂ value (0 V => 0 ppm, 10 V => 2 000 ppm, 7 V => 1 400 ppm)
- "-": no input is used
- Ventil. % => ventilation instructions (0-100 %) (0 V => minimum ventilation 0 % without jumper on main module, 10 % with jumper on main module)



If no input is connected, the cursor must be in the central position.

2 OUTPUT





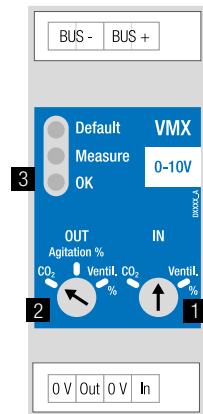













Regulate the OUT voltage output (0-10 V - maximum 20 mA):

- CO₂*: a CO₂ value (0-2,000 ppm) requires a CO₂ sensor on the installation (0 V => 0 ppm, 10 V => 2,000 ppm, 4 V => 800 ppm)
- Motion %: an motion value (0-100%) requires one or more optical sensors on the installation (motion level calculated on the last ten minutes, 0 V => 0 % motion, 10 V => 100 % motion)
- Ventilation %: level of ventilation (0-100%) (level of ventilation calculated on the last 10 minutes, 0 V => 0 % ventilation, 10 V => 100 % ventilation)



3 Interpretation of signals

BEHAVIOUR OF THE LEDS

	Default				 (fast)	 (x4)
	Measure					
	OK	 (flashes)				
	INTERPRETATION	operating OK	Update input / output (every ten seconds)	system not configured	Change of configuration without new memorisation of the main module	a module or a sensor is not working correctly

* This sensor then takes the place of the CO₂ sensor. If another CO₂ sensor is connected, then the system is not operational.

12.5. ASSEMBLY

* This sensor then takes the place of the CO₂ sensor. If another CO₂ sensor is connected, then the system is not operational.

12.6. ELECTRICAL CONNECTION

Connect the module according to the wiring diagrams provided in this document.

Bus Terminal:

- it receives electrical power and exchanges information with all the other elements in the system.
- connected to the bus by two wires with section 1.5 or 2.5 mm² (flexible or rigid)
- **maximum number of IN OUT 0-10 V modules per main module: 1**

IN, OUT Terminal:

- external communication (BMS for example)

13. DIFFUSERS

Aereco offers diffusers from TROX brand, **XARTO series**. These diffusers are perfectly compatible with the system and with the valves used in the VMX system. **Nevertheless, other types of diffusers may be used, providing the diameters are compatible with the network and the flows they offer are compatible with those of the VMX system valves.**

Where diffusers other than those offered by Aereco are chosen, special attention must be paid to the acoustic performance and air diffusion of the selected product.

Diffuser

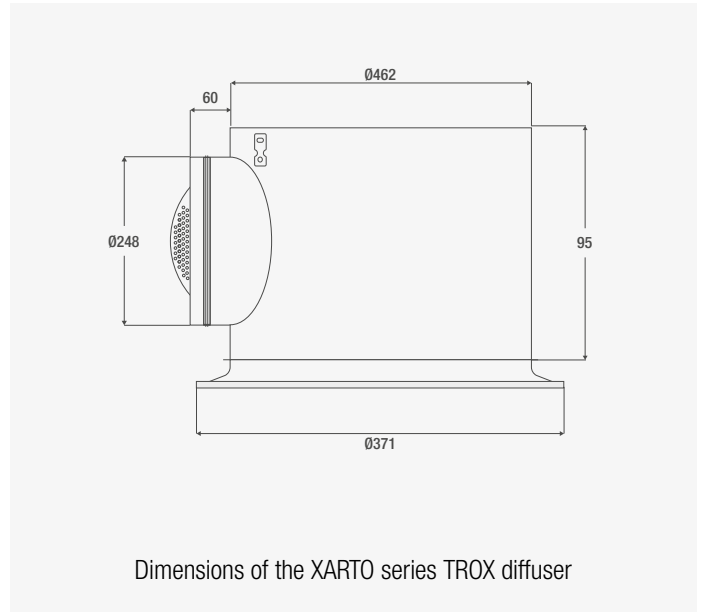
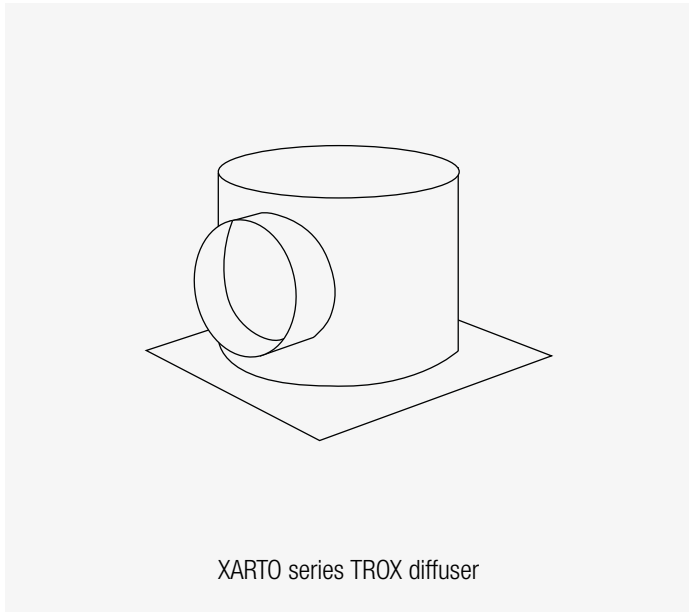

14. FANS

Aereco offers different models of fans compatible with the VMX system. Their pressure regulation system, low consumption and flows ranging from 500 to 6,000 m³/h make **the VCZ and VTZ models particularly suitable**.

The VCZ model is intended for an interior installation protected from the rain; the VTZ model is intended for an external installation on the roof.

Other fans may be used with the VMX system, providing they can reach the flows expected and offered by the motorised valves. Preference must be given to fans with low energy consumption and offering good acoustic performance.

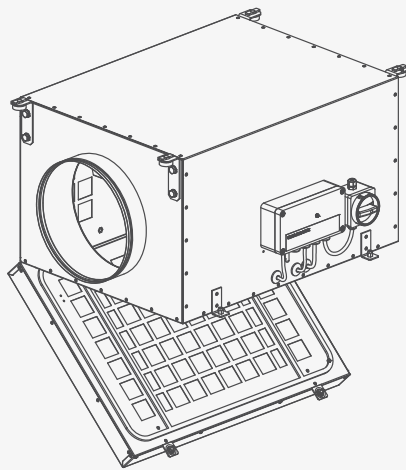

Aereco fan, VCZ model

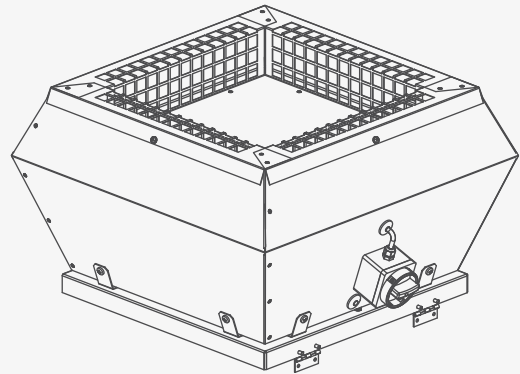

Aereco fan, VTZ model

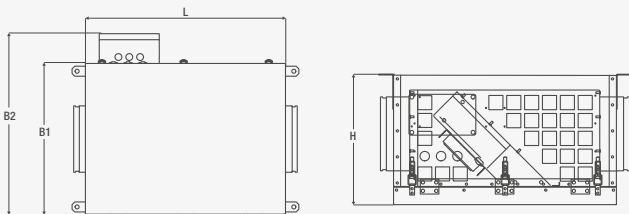

Dimensions of the VCZ model

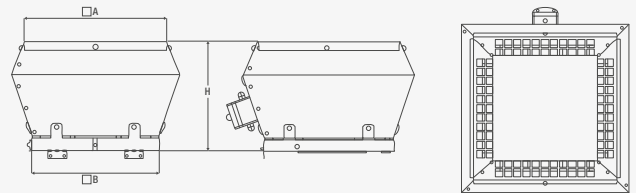

Dimensions of the VTZ model

	VCZ 0	VCZ 1	VCZ 2	VCZ 3	VCZ 4
øD [mm]	200	250	355	400	500
H [mm]	350	400	550	550	741
L [mm]	600	600	600	600	800
B1 [mm]	455	455	545	545	740
B2 [mm]	543	543	633	633	832

	VTZ 0	VTZ 1	VTZ 2	VTZ 3	VTZ 4	VTZ 6
A [mm]	445	547	720	720	954	954
B [mm]	340	440	600	600	707	707
H [mm]	290	338	400	400	577	577



Aereco S.A.
62 rue de Lamirault
Collégien
77615 MARNE LA VALLEE CEDEX 3
FRANCE
www.aereco.com