

New

VBP+

Assistance fan for hybrid ventilation



With the reinforcement of performance requirements, the building sector keeps on looking for innovative solutions that can meet advantageously energy performance and indoor air quality, without forgetting maintenance and investment costs management.

No doubt that hybrid ventilation offers a very relevant answer to this issue, for the new built but also for the retrofiting. With the VBP+ hybrid fan, Aereco has improved again the relevancy of the system. Its low pressure enables the use of existing natural ventilation ducts with no need to improve their airtightness while the optimised design and motor reduce the electrical consumption at the lowest, so the cost for the owners.

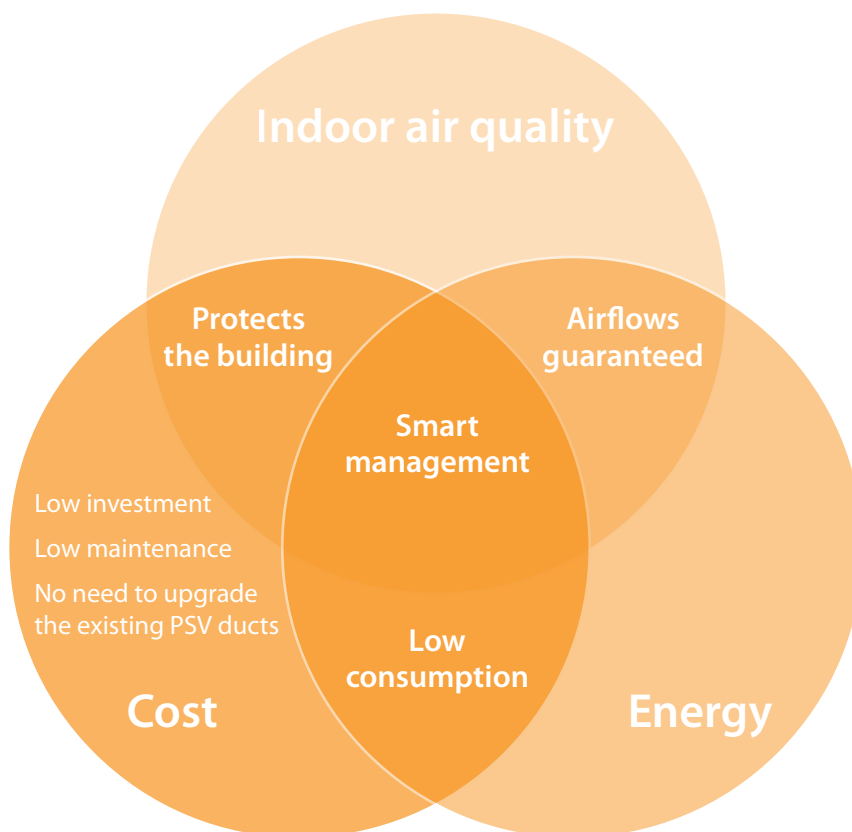

VBP+

Hybrid ventilation, more **energy efficient** than ever

With only 35 W at 800 m³/h*, the VBP+ hybrid ventilation fan offers an exceptional energy efficiency, reducing the electrical consumption due to ventilation to the minimum. Moreover, its **hybrid working** (natural or mechanical mode)** enables to automatically adapt to weather conditions to maintain the pressure in the ductwork, all year long. The VBP+ is specially designed for demand controlled ventilation (humidity sensitive, presence detection or other activation modes). Located on a terrace or on a slope roof, the VBP+ is easily installed on the top of chimney through adaptation parts. Its large free area (equivalent to 8 ducts Ø 125 mm) allows to gather several collective or individual ducts without reducing the cross section.

Not critical in case of supply default with its patented blades design, the VBP+ requires a very light maintenance in comparison with standard mechanical systems, making of it a privileged solution for social housing. The VBP+ hybrid fan is also designed to resist to fire smokes with its body and structure in galvanised steel, and with a non combustible calcium silicate board that protects the EC motor.

The VBP+ hybrid ventilation fan is the ideal solution for the renovation of buildings using natural (passive stack) ventilation ducts; it can also be a relevant answer to the new built, always seeking for improved energy efficiency.



Only 35 W at 800 m³/h* thanks to EC motor and demand controlled airflows

Up to 1 000 m³/h at 20 Pa

Hybrid working: allows operation in natural ventilation when very low speed

Constant pressure: adapted to demand controlled ventilation

Fire safety: can resist to smokes up to 400°C during 30 minutes

Adapts to weather conditions: management system (MS version) with temperature sensor

Alarm output**

EC motor

Renovation or new built on natural ventilation ductworks

Low maintenance: low air speed = lower dusting

Not critical: ensures natural ventilation if the fan stops



Patented smart blades design

The unique smart blades design of VBP+ prevents from creating pressure loss when stopped: its central blades are parallel to the airflow, the airflow being generated through static peripheral paddles. Thus, the system offers a no-critical characteristic in case of supply failure as it then works on one of its two modes, the natural ventilation.

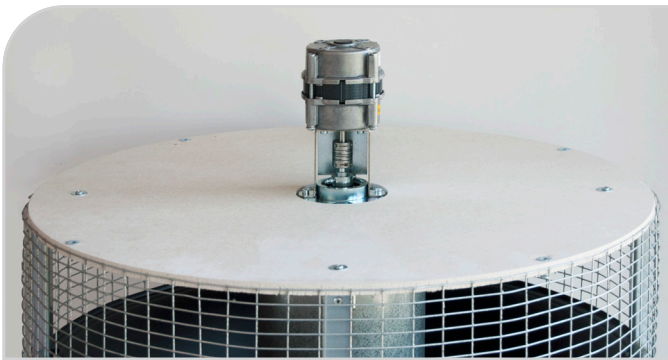

Fire safety

Thanks to body and structure in galvanised steel, a non combustible matrix made of calcium silicate that protects the motor, VBP+ can resist to fire smokes up to 400°C during 30 minutes.

Hybrid ventilation: how it works?

Between natural and mechanical exhaust ventilation, hybrid ventilation is a modern concept which consists in using the components and dimensioning of the natural ventilation ducts coupled to a non-permanent low pressure mechanical exhaust ventilation assistance. The mechanical exhaust ventilation assistance is used in addition with the natural forces (thermal draught and wind), when they are not sufficient. The working of the VBP+ fan is automatic: the temperature sensor drives the speed then the pressure according to the external temperature, progressively.

The air is admitted in the dwellings by humidity controlled air inlets located in the bedrooms and living rooms; it is evacuated in the wet rooms (toilets, bathroom and kitchen) through demand controlled exhaust units.

G2H-type exhaust grilles are particularly suitable for hybrid ventilation as they are designed to work at low pressures and benefit from numerous activation modes that improve their energy and IAQ performance. These are connected to the exhaust fans through collective or individual ducts. The pressure generated in hybrid ventilation are comparable to those of natural ventilation (about of 5 to 20 Pa) at the level of the exhaust units.

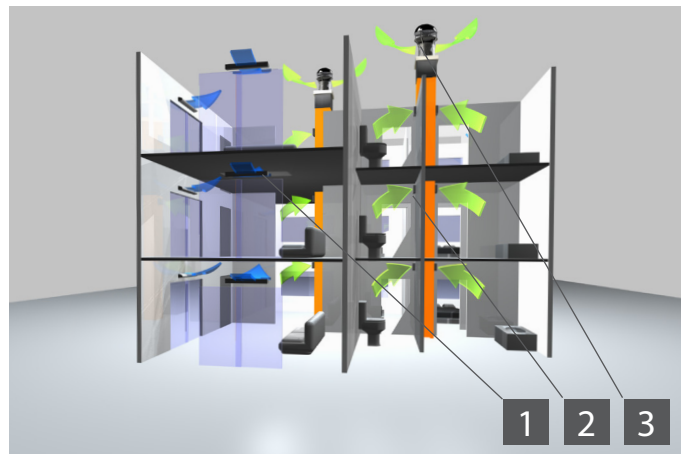

Humidity controlled air inlets

1



Demand controlled exhaust grilles

2



VBP+ hybrid fans

3

Better controlled airflows, all year long with the management system

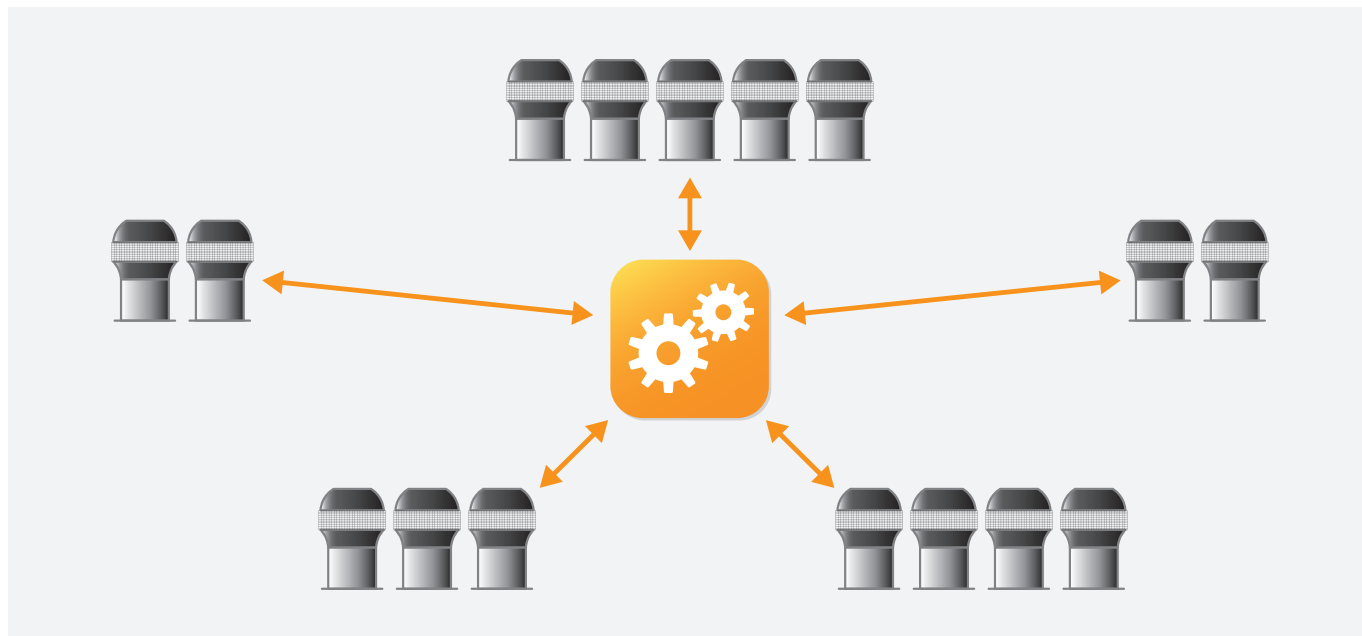

When connected to its management system (MS), VBP+ uses the temperature to control the speed of a group of fans which power can be set according to the configuration of the building (height of the duct, type of connected dwellings, etc.). In addition, the system gives an alarm output and default indicator. VBP+ can be delivered in MS or ST preset configuration (two different codes).

Main features of the MS management system are simultaneous operation of the fans grouped* (per stack of dwellings for example), fan power that can be set individually, according to requested airflows, information output (alarm) and default indicator.

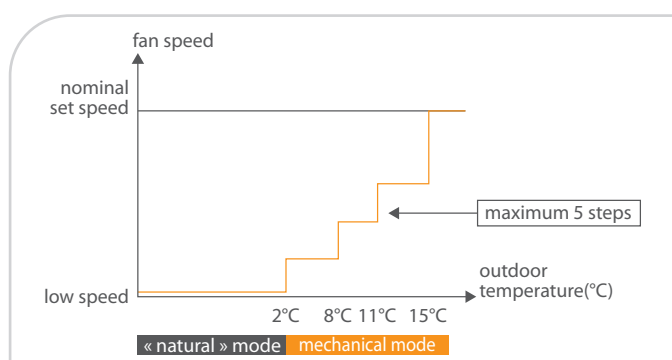

Working according to the outdoor temperature

The fan speed depends on the temperature as on the configuration, as described on the scheme. When the temperature is lower than 2°C, the fan speed is low, then the system works in a "natural ventilation" mode: the thermal draught and the wind are then the main drivers for ventilation.



Two specific modules

The management system consists of 2 specific modules (one main module for up to 5 groups of fans, so up to 25 fans and one "VBP+" module per fan) supplied by Aereco. These modules are clipped on rail DIN in an electrical box, connected to a standard 230 VAC – 5 V supply and to a specific temperature probe. See the complete schema page 7.

*up to 5 fans in one group, up to 5 groups per main module.

VBP+

Hybrid fan		VBP+
Code		VB21116 / VB21124
Airflow characteristics		
Maximum airflow	m ³ /h	1 000 (max. 20 Pa)
Maximum pressure	Pa	35 Pa (@ 200 m ³ /h)
Electrics		
Motor type		EC (Electronic commutation)
Power supply		230 VAC, 50-60 Hz
Maximum power	W	43
IP degrees of protection		IP54
Control / speed definition		By integrated potentiometer (VB21116) or management system (VB21124)
Characteristics		
Weight	kg	20
Colour		metal grey / black
Material (envelope)		galvanised steel / PE
External dimensions	mm	904 / Ø 610
Installation		
Number of available draft connections		1
Outlet	mm	Ø 354
Installation		Installation on terrace, head of the air duct 3 x screws Ø 8 mm
Working		
Driven propeller		by axis / motor coupler
Maximum speed	RPM	600
Accessories		
Modules		For VB21124 only: "VBP+" module (ref. VB21118) and "main" module (ref. VB21119)

Management system (MS)	
Number of fan groups by main module	1 to 5
Number of fans per group	1 to 5
Electrical box (not included)	IP65, rail DIN
Default indicator	■
Control of each other fan power	■
Control of the working – stop of the group in case of supply failure	■
Hybrid management: natural / mechanical	■
Alarm output (relay output)	5 V – max 200 mA
Temperature sensor	Specific

Aeraulic and power consumption

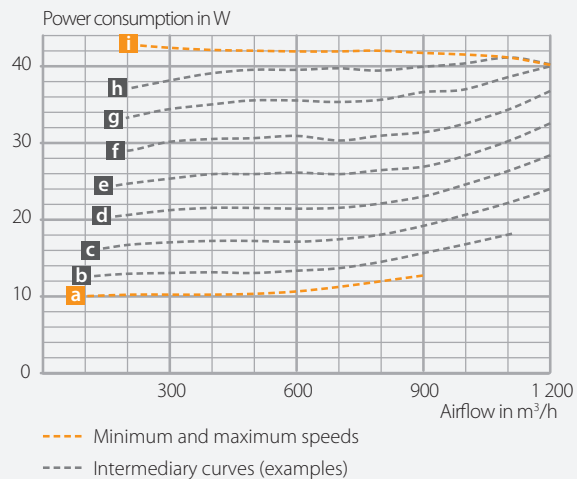
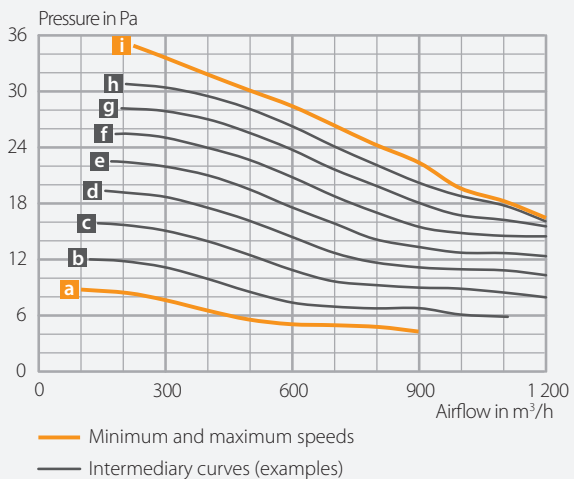

Dimensions

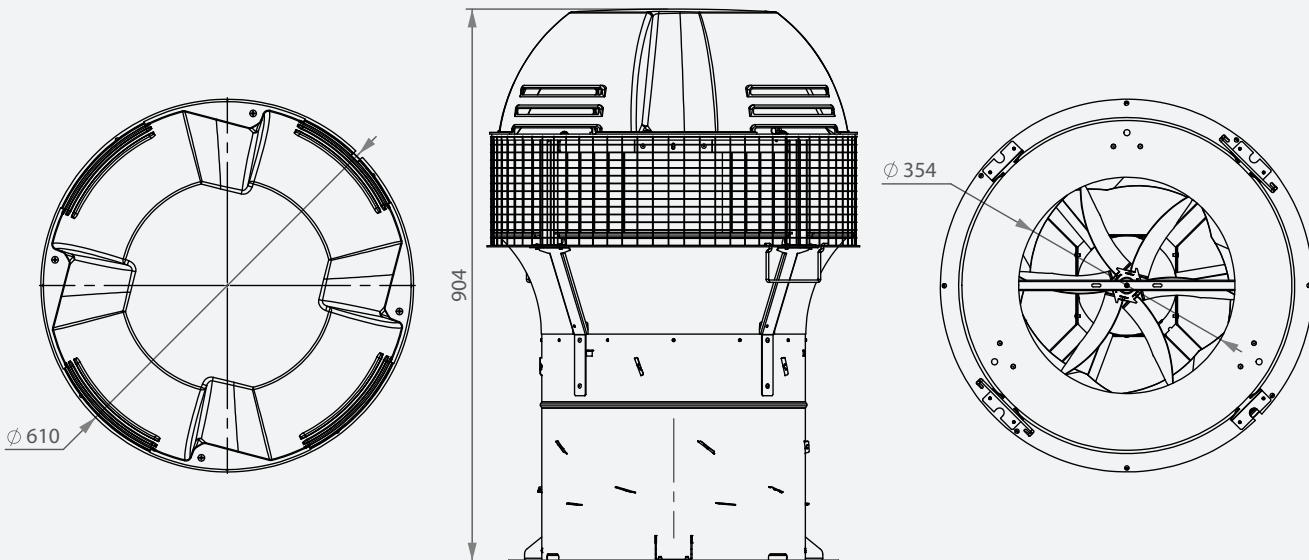

Components of the management system (MS)

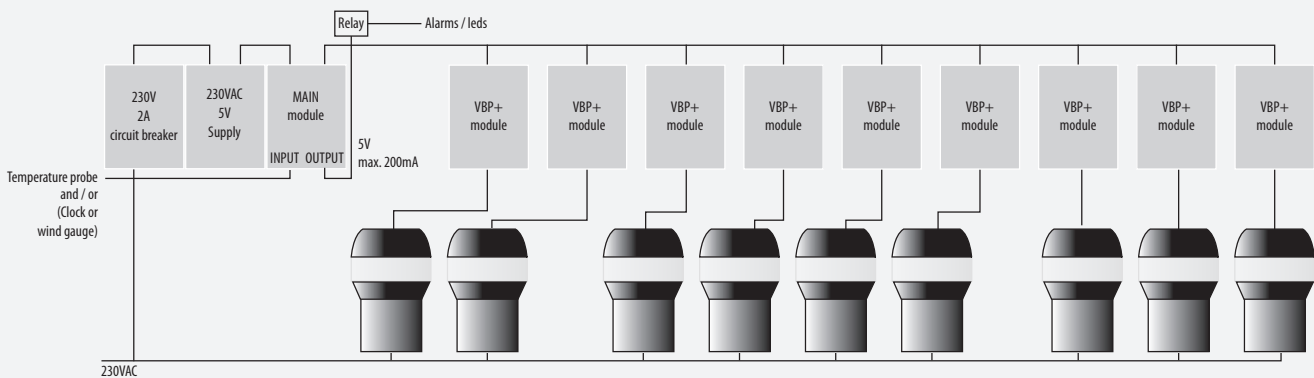



Aereco S.A.

9 allée du Clos des Charmes - Collégien
77615 Marne la Vallée Cedex 3 - FRANCE

www.aereco.com