

## LED LIGHT BOX MF19 (MAGNET)

DATA SHEET



**LED Light Box MF19** is sleek with a non-obtrusive flush-faced frame for displaying printed graphics. It is especially popular for backlighting high quality Duratrans photographic images.

LED Light Box MF19 is a sleek flush-faced frame for displaying printed graphics. It is very popular for backlighting high quality Duratrans photographic images.

The light box is made up of two parts. The rear part provides very evenly lit backlighting and is mounted to a wall or other supporting structure. The front part is an acrylic cover plate to which the printed graphic is fixed with magnetic strips. This

graphic assembly is clipped on to the rear part with another set of strong magnets.

The total thickness of this LED Light Box is only 19mm. It is the slimmest light box with a 'lift-off' frame available on the market.

The size, frame colour and border can be customised. A waterproof and lockable version is available for use outdoors.

## PRODUCT FEATURES



- Attractive appearance, ultra-thin
- Standard frame colour is anodised aluminium colour. Other colours on request
- Simple mounting, easy to install graphic
- Input voltage: 12V or 24V
- Visible surface: Single sided
- Power: 12W-120W

## TECHNICAL DATA

Voltage	LED strip type	Current/unit	Power/m
12V	PL-RS1180	60mA	12W/m
24V	PL-RS1180	30mA	22W/m

## SPECIFICATIONS

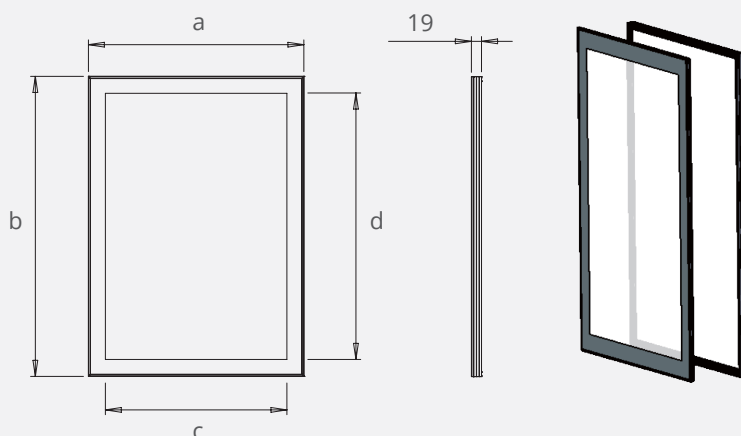

- Addlux Light Sheet with magnetic lift-off frame, acrylic cover and external 12V or 24V DC PSU
- Total thickness of just 19mm.

Size	Frame Size (mm) a × b	Visible Size (mm) c × d	Graphic Size (mm)
A4	321x 234	262 x 175	297 x 210
A3	321 x 444	262 x 385	297 x 420
A2	444 x 618	385 x 559	420 x 594
A1	618 x 865	559 x 806	594 x 841
A0	1213 x 865	1154 x 806	1189 x 841
Custom (max)	< 3000 x 1500	< 2941 x 1441	Enquire