

Acusorb[®] Tessere

Product Range & Technical Details

Revision 1.0



Acusorb® Tessere Introduction.

Product Overview

The Acusorb® Tessere range of acoustic wood wool panels were initially used as large building blocks much the same as breeze blocks and to insulate buildings, whereas today they have been recognised for their superb acoustic characteristics offering both sound absorption and sound insulation. The natural look and feel of Tessere make them a perfect surface lining resistant to both water and fire, A2 rated - EN 13501-1:2007. Acusorb® Tessere are widely sought after and used within varying interior design solutions across the globe. Our products are exported across Europe, USA and the Asia. Our company focus is to continuously work on optimization of design and production processes, launching innovative new product aesthetics and educating market sectors. Together with field experts, architects, interior designers, builders and specifiers, preconditions are established with the aim to take full advantage of Acusorb® Tessere's unique applications. The Tessere range of products are manufactured using a totally natural, environmentally friendly material that is harmless to human health and manufactured using top-quality wood wool strands, portland cement and mixed with recycled water to bind them. Acusorb® Tessere offers an extremely durable and high impact acoustic solution.



Wood Wool



Portland Cement



Water

100% Natural Ingredients

Each panel type, be it the **Acusorb® Tessere Solu**, Tessere Geo or Tessere Baffle combine great looks with performance transforming a space to house aesthetically pleasing visuals and acoustic performance. Acusorb® Tessere range of panels are both a perfect surface design solution to any new build offering structural integrity and a perfect retrofit solution to your existing build that will totally transform the space with a simple upgrade. Acusorb® Tessere wood wool panels are designed to achieve the highest acoustic performance without compromising on style. Their purpose is to tackle unwanted noise, enabling the optimum level of acoustic comfort. Acusorb® Tessere panel systems reduce reverberant noise that is perceived as “echo” offering heightened speech intelligibility and acoustic tranquillity in any space.

Simply locate and easily fit **Acusorb® Tessere Baffles**, Tessere Solu and **Acusorb® Tessere Geo** panels with a selection of mounting options enabling a refreshed visual appeal, enhanced sound absorption, noise control and design flexibility with rapid installation. The Tessere acoustic wall and acoustic ceiling panels are simply fixed or suspended using standard T15/24 ceiling grid systems, adjustable drop wire options for baffles or simply screw-fix into position. The Acusorb® Tessere acoustic panel range are therefore easily removed for either panel relocation or building maintenance. Acusorb® Tessere acoustic panels come in a range of colours offering the natural look, colour variation with an aesthetically pleasing texture. Acusorb® Tessere acoustic panels require very little maintenance. The Tessere wood wool panels not only ensure excellent acoustic results but also offer superb visual characteristics enhancing the dynamics and appearance of any space. These acoustic panels are available in a variety of sizes, wood strand thicknesses, colours and shapes and are typically 15mm, 25mm and 50mm thick.

“Clean natural looks, great fire performance, unrivalled acoustic absorption, superb noise control characteristics”

Acusorb® Tessere are a perfect accompaniment to any internal space where reflective sound is an issue. Suited to control sound in large atriums, car parks, sports halls, concert halls, lecture theatres, cinemas, hotels, restaurants, lobbies, reception areas and large public interior spaces.





Wood Wool Acoustic Panels.

Acusorb® Tessere Cement Formed Wood Wool Acoustic Wall Panels.

Acusorb® Tessere wood wool acoustic wall & ceiling lining system. 'Class A' acoustic performance, a perfect retrofit solution where 'echo' is a perceived problem.



ft. Geo wall panels



ft. 3.0mm strands

Acoustic Performance.

Practical 3rd octave sound absorption coefficient α_s in accordance with BS EN ISO 354. Extended sound absorption coefficient α_w and sound absorption when tested in accordance BS EN ISO 11654-1997.

(Typical values showing air gaps and a mineral fibre filled void (Mineral Fibre density typically 90kg/m^3)

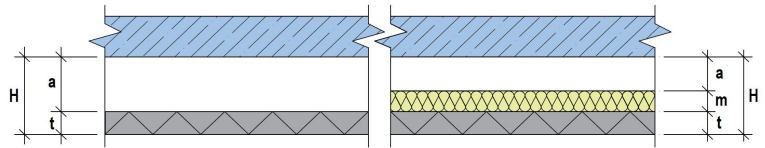

H - height. a - air gap. m - mineral fibre. t - Acusorb Tessere.

AcuSorb® Tessere Solu	Height	Sound Absorption Coefficient α_s (tested to BS EN ISO 354) Octave Bands (Hz)								Building Regulations Absorber Classification When tested to BS EN ISO 11654-1997
		125	250	500	1k	2k	4k	α_w	NRC	
25mm Solu panel, with 50mm mineral fibre, without air gap	75mm	0.35	0.70	1.00	0.95	0.85	0.95	0.90	0.88	A
15mm Solu panel, with 50mm** mineral fibre, without air gap	65mm	0.30	0.65	1.00	0.85	0.75	0.80	0.85	0.81	B
50mm Solu panel, without mineral fibre, 200mm air gap	250mm	0.40	0.60	0.55	0.65	0.70	0.70	0.80	0.63	C

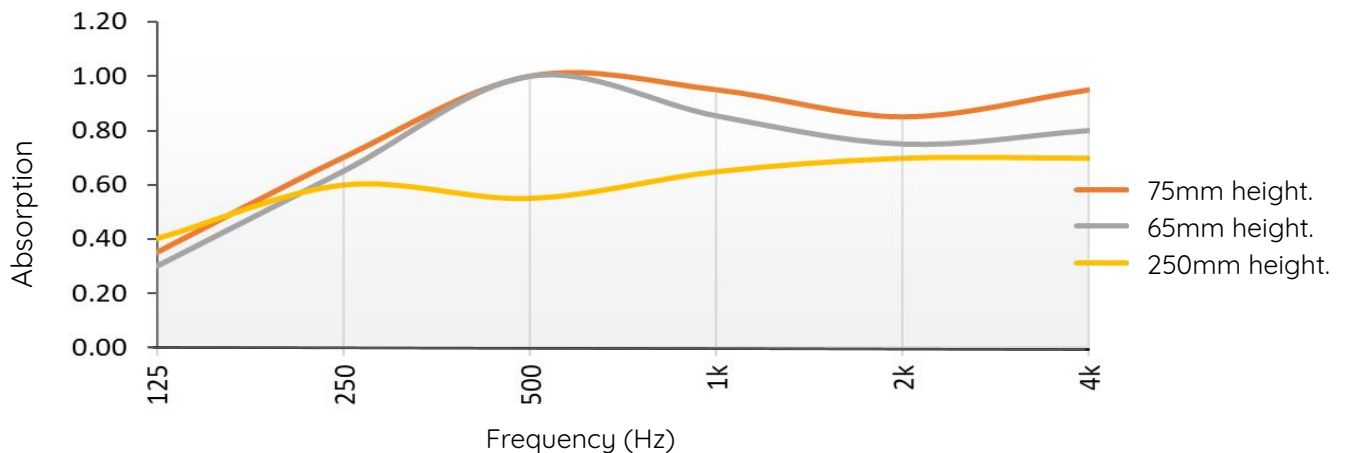



Wood Wool Acoustic Panels.

Acusorb[®] Tessere Cement Formed Wood Wool Acoustic Wall Panels.

Acusorb[®] Tessere wood wool acoustic wall & ceiling lining system. 'Class A' acoustic performance, a perfect retrofit solution where 'echo' is a perceived problem.



ft. Solu ceiling panels

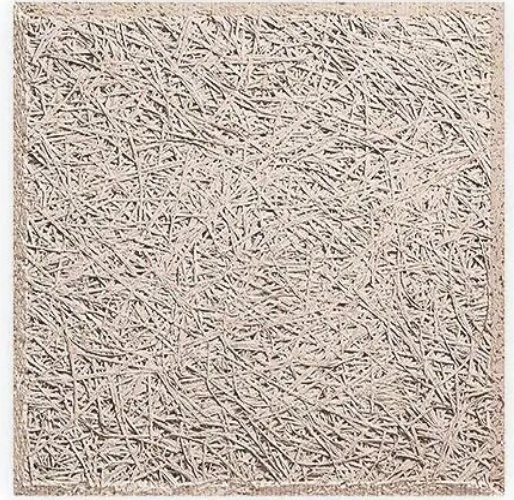

ft. 1.0mm strands

Acoustic Performance.

Practical 3rd octave sound absorption coefficient α_s in accordance with BS EN ISO 354. Extended sound absorption coefficient α_w and sound absorption when tested in accordance BS EN ISO 11654-1997.

(Typical values showing air gaps and a mineral fibre filled void (Mineral Fibre density typically 90kg/m³)

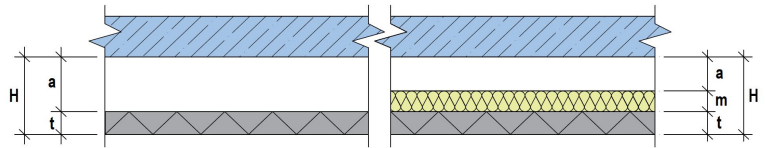

H - height. a - air gap. m - mineral fibre. t - Acusorb Tessere.

AcuSorb [®] Tessere Solu	Height	Sound Absorption Coefficient (tested to BS EN ISO 354) Octave Bands (Hz)								Building Regulations Absorber Classification When tested to BS EN ISO 11654-1997
		125	250	500	1k	2k	4k	α_w	NRC	
25mm Solu panel, with 50mm mineral fibre, without air gap	75mm	0.35	0.70	1.00	0.95	0.85	0.95	0.90	0.88	A
15mm Solu panel, with 50mm** mineral fibre, without air gap	65mm	0.30	0.65	1.00	0.85	0.75	0.80	0.85	0.81	B
50mm Solu panel, without mineral fibre, 200mm air gap	250mm	0.40	0.60	0.55	0.65	0.70	0.70	0.80	0.63	C

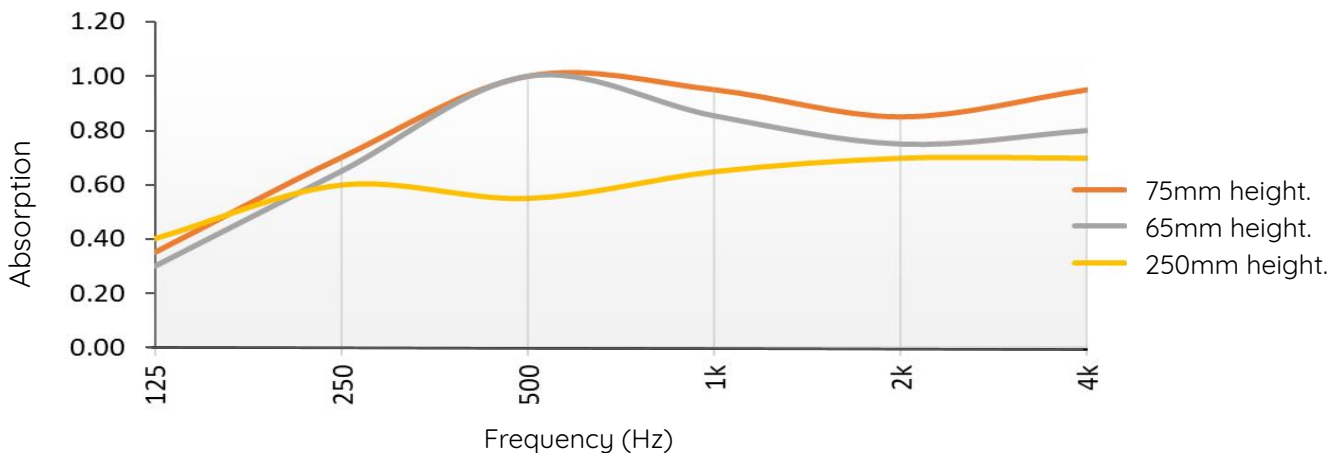



Wood Wool Acoustic Panels.

Acusorb[®] Tessere Cement Formed Wood Wool Acoustic Ceiling Baffles.

Acusorb[®] Tessere wood wool suspended acoustic baffle system. 'Class C' acoustic performance, a perfect retrofit solution where 'echo' is a perceived problem.



ft. Baffle wave panels

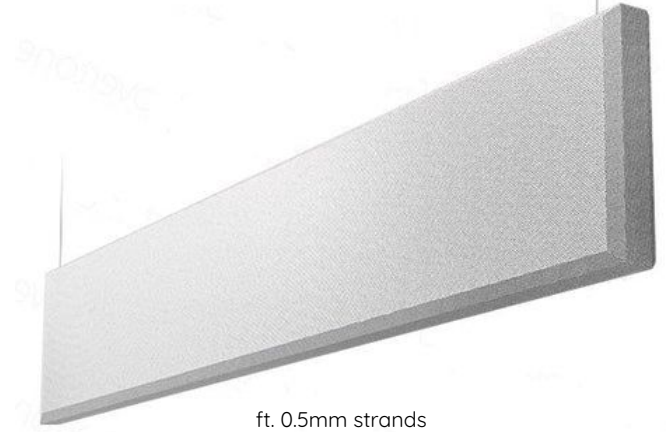

ft. 0.5mm strands

Acoustic Performance.

Practical 3rd octave sound absorption coefficient α_s in accordance with BS EN ISO 354. Extended sound absorption coefficient α_w and sound absorption when tested in accordance BS EN ISO 11654-1997.

(Typical values showing the baffle in the 'J' mounted vertical position - always a 'Class C' absorber no matter the thickness) 50mm thickness available on request.

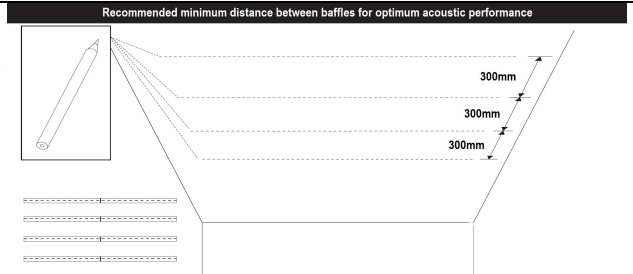

AcuSorb [®] Tessere Baffle	Thickness	Sound Absorption Coefficient (tested to BS EN ISO 354) Octave Bands (Hz)							Building Regulations Absorber Classification When tested to BS EN ISO 11654-1997
		125	250	500	1k	2k	4k	NRC	
300mm centres	30mm	0.65	0.67	0.10	1.00	1.00	0.99	0.92	C
400mm centres	30mm	0.54	0.51	0.88	1.00	1.00	1.00	0.85	C
600mm centres	30mm	0.47	0.50	0.90	1.00	0.97	0.95	0.84	C

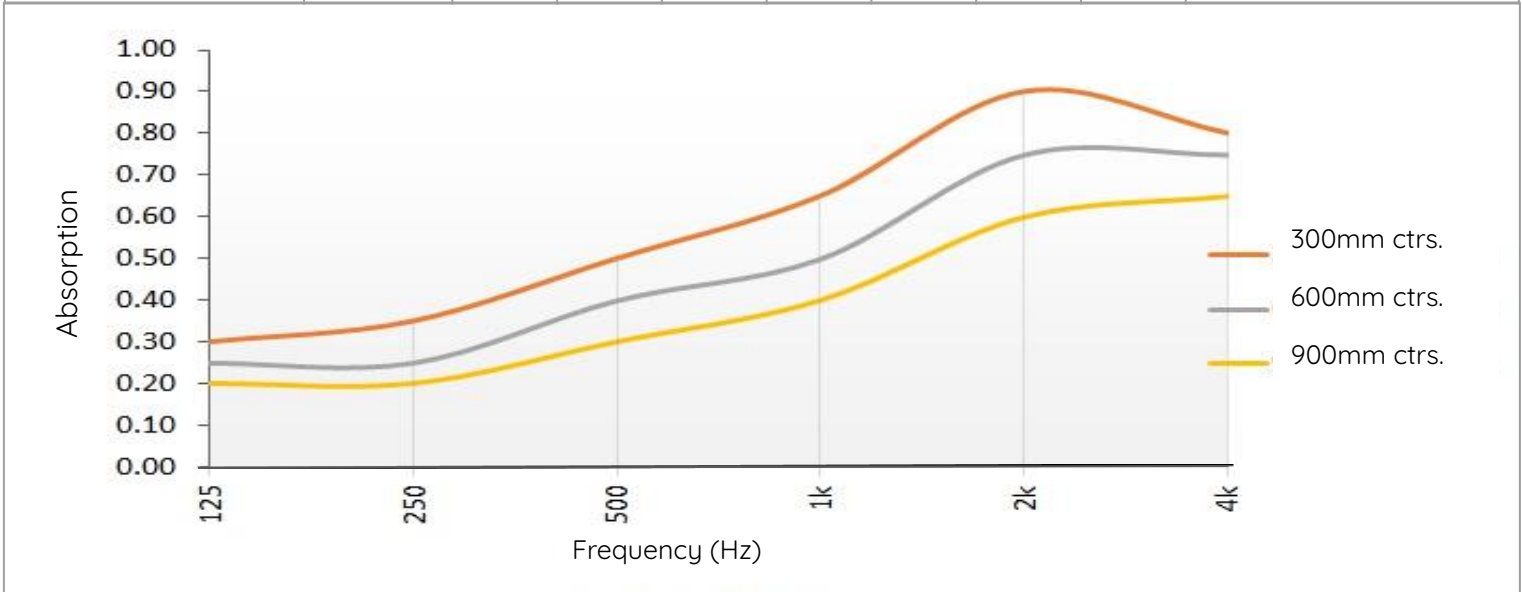



Acusorb Tessere Panel Applications.

Acusorb® Tessere Solu, Geo and Baffle acoustic wood wool panels are manufactured using top-quality wood wool strands, portland cement and mixed with recycled water to bind them. The main advantages to Acusorb® Tessere acoustic panels are their excellent sound absorption characteristics, they are dimensionally stable under temperature fluctuations, extremely durable offering a High-Impact solution and stable under humid conditions. Acusorb® Tessere wall and ceiling panels are energy saving panels offering superior thermal insulation properties making them ideal for areas using a 'thermal mass construction' air tightness building method.



Sports Facility Drop Ceiling

Functional with style, designed for sound control.

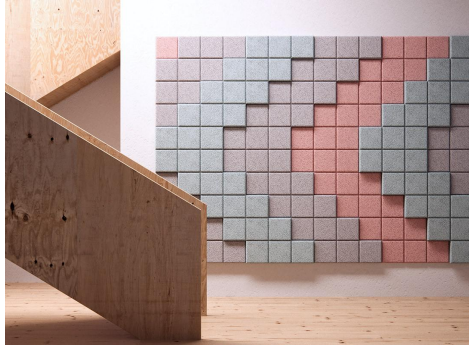

Open Area 3D Geo Panels

Let the imagination run wild, quieten down an otherwise noisy space.



Car Park Fire Rated Soffit Boards

Noise control designed with safety at the forefront.



Communal Space Solu Panels

Organised lines, high absorption designed for speech intelligibility.

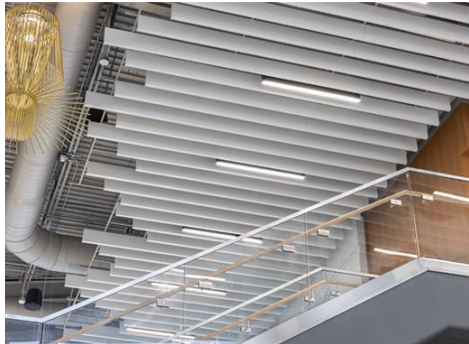

Atrium Scatter Baffle

Scattered effect to hide services and incorporate lighting.



Studio Geo Entwined Hex Panels

Staggered effect for maximum absorption designed for speech intelligibility.



Wood Wool, Cement & Water, Acoustic Design with Durability & Fire

Wood Wool wall and ceiling treatments for both acoustic and thermal applications are one of the most effective retrofit solutions for sound reduced working environments. Perfect for offices, auditoriums, sports halls, locker rooms, classrooms, restaurants and more commercial environments. Acusorb® Tessere acoustic panels come in a multitude of colour options and can have 'Class A' acoustic performance characteristics. With a range of shapes, strand sizes and panel dimensions, it allows versatility to create that specific design with functionality and beauty.

Standard colours and strand variants available. Other more bespoke colours can be looked at upon request.



Acusorb[®] Tessere Panel Applications.

Acusorb[®] Tessere acoustic panels are widely used in both the interiors of public and residential buildings. They are typically suitable for hanging ceiling constructions and interior wall decoration. Due to their natural composition and outstanding features, they are widely used in buildings with increased acoustic load, where sound insulation and noise absorption play an important role.



Walls.



Ceilings.



**Construction
Panels for Thermal
Insulation.**



Technical Properties.

Acusorb Tessere® Acoustic Panels - 0.5mm Strand Width		0.5
Thickness	25mm	
Size (screw-fasten panels)	600 x 600mm, 1200 x 600mm, 2400 x 600mm	
Size (suspended ceiling panels)	595 x 595mm, 1195 x 595mm	
Dimensional tolerance (BS EN 13168)	L4, W2, T2, S2, P2	
Surface weight kg/m ²	10.5kg	
Density (mass) kg/m ³	420kg	
Thermal resistance (Ro) m ² K/W	0.35	
Thermal conductivity (λD) W/mK	0.066	
Bend (BS EN 12089) kPa	≥ 1300	
Compression (EN 826) kPa	≥ 300	
Chloride content (EN 13168) %	≤ 0.06 class Cl3	
Reaction to fire (BS EN 13501-1:2007)	B-s1, d0	

Acusorb Tessere® Acoustic Panels - 1.0mm Strand Width					1.0
Thickness	15mm	25mm	35mm	50mm	
Size (screw-fasten panels)	600 x 600mm, 1200 x 600mm, 2400 x 600mm				
Size (suspended ceiling panels)	595 x 595mm, 1195 x 595mm				
Dimensional tolerance (BS EN 13168)	L4, W2, T2, S2, P2				
Surface weight kg/m ²	7.0kg	10.5kg	14.5kg	19.5kg	
Density (mass) kg/m ³	470kg	420kg	410kg	390kg	
Thermal resistance (Ro) m ² K/W	0.20	0.35	0.50	0.75	
Thermal conductivity (λD) W/mK	0.066				
Bend (BS EN 12089) kPa	≥ 1700	≥ 1300	≥ 1000	≥ 700	
Compression (EN 826) kPa	≥ 300	≥ 300	≥ 200	≥ 200	
Chloride content (EN 13168) %	≤ 0,06 class Cl3				
Reaction to fire (BS EN 13501-1:2007)	B-s1, d0				



Technical Properties.

Acusorb Tessere® Acoustic Panels - 1.5mm Strand Width					1.5
Thickness	15mm	25mm	35mm	50mm	
Size (screw-fasten panels)	600 x 600mm, 1200 x 600mm, 2400 x 600mm				
Size (suspended ceiling panels)	595 x 595mm, 1195 x 595mm				
Dimensional tolerance (BS EN 13168)	L4, W2, T2, S2, P2				
Surface weight kg/m ²	7.0kg	10.5kg	13.5kg	18.5kg	
Density (mass) kg/m ³	470kg	420kg	380kg	370kg	
Thermal resistance (Ro) m ² K/W	0.20	0.35	0.50	0.75	
Thermal conductivity (λD) W/mK	0.066				
Bend (BS EN 12089) kPa	≥ 1700	≥ 1300	≥ 1000	≥ 700	
Compression (EN 826) kPa	≥ 300	≥ 300	≥ 200	≥ 200	
Chloride content (EN 13168) %	≤ 0,06 class Cl3				
Reaction to fire (BS EN 13501-1:2007)	B-s1, d0				

Acusorb Tessere® Acoustic Panels - 3.0mm Strand Width <i>(produced on request)</i>				3.0
Thickness	25mm	35mm	50mm	
Size (screw-fasten panels)	600 x 600mm, 1200 x 600mm, 2400 x 600mm			
Size (suspended ceiling panels)	595 x 595mm, 1195 x 595mm			
Dimensional tolerance (BS EN 13168)	L4, W2, T2, S2, P2			
Surface weight kg/m ²	10.5kg	13.5kg	18.5kg	
Density (mass) kg/m ³	420kg	410kg	390kg	
Thermal resistance (Ro) m ² K/W	0.35	0.50	0.75	
Thermal conductivity (λD) W/mK	0.066			
Bend (BS EN 12089) kPa	≥ 1300	≥ 1000	≥ 700	
Compression (EN 826) kPa	≥ 300	≥ 200	≥ 200	
Chloride content (EN 13168) %	≤ 0,06 class Cl3			
Reaction to fire (BS EN 13501-1:2007)	B-s1, d0			



Technical Properties.

Acusorb Tessere® (A2) Acoustic Panels - 1.0mm Strand Width			1.0.A2
Thickness	15mm	25mm	
Size (screw-fasten panels)	600 x 600mm, 1200 x 600mm, 2400 x 600mm		
Size (suspended ceiling panels)	595 x 595mm, 1195 x 595mm		
Dimensional tolerance (BS EN 13168)	L4, W2, T2, S2, P2		
Surface weight kg/m ²	12.5kg	14.5kg	
Density (mass) kg/m ³	830kg	580kg	
Thermal resistance (Ro) m ² K/W	N/A	0.30	
Thermal conductivity (λD) W/mK	0.0701	0.074	
Bend (BS EN 12089) kPa	≥ 1700	≥ 1300	
Compression (EN 826) kPa	≥ 500	≥ 500	
Chloride content (EN 13168) %	≤ 0,06 class Cl3		
Reaction to fire (BS EN 13501-1:2007)	A2-s1, d0		

Acusorb Tessere® (A2) Acoustic Panels - 1.5mm Strand Width			1.5.A2
Thickness	15mm	25mm	
Size (screw-fasten panels)	600 x 600mm, 1200 x 600mm, 2400 x 600mm		
Size (suspended ceiling panels)	595 x 595mm, 1195 x 595mm		
Dimensional tolerance (BS EN 13168)	L4, W2, T2, S2, P2		
Surface weight kg/m ²	12.5kg	14.5kg	
Density (mass) kg/m ³	830kg	580kg	
Thermal resistance (Ro) m ² K/W	N/A	0.30	
Thermal conductivity (λD) W/mK	0.0701	0.074	
Bend (BS EN 12089) kPa	≥ 1700	≥ 1300	
Compression (EN 826) kPa	≥ 500	≥ 500	
Chloride content (EN 13168) %	≤ 0,06 class Cl3		
Reaction to fire (BS EN 13501-1:2007)	A2-s1, d0		



Strand Awareness.

1.0mm, 1.5mm, 3.0mm



Standard Colour Variations.

Natural



Natural painted



White painted



Grey painted



Black painted



Taken from RAL or NCS colour chart

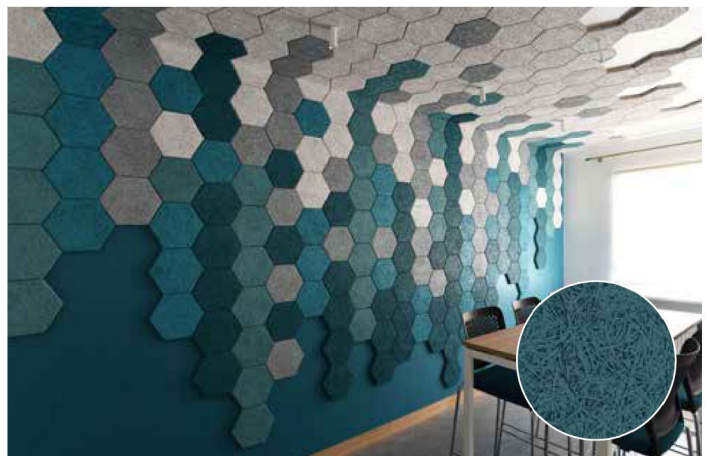



Profile Specifications.

P0, P5, P11, P0-T24, P0G-T24, P5G-T24, P5H, P5S

Acusorb® Tessere Wood Wool panel edge details suitable for both walls and ceilings.

P0 - Panel without chamfer

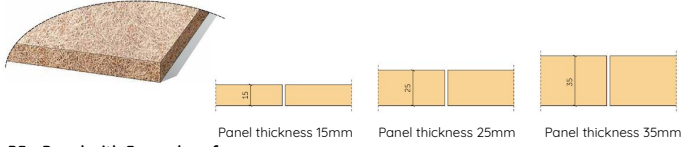

P5 - Panel with 5mm chamfer

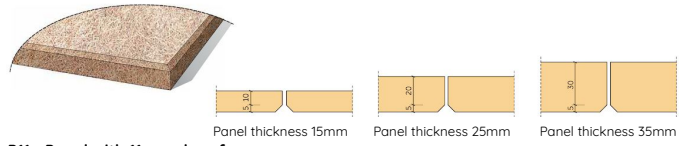

P11 - Panel with 11mm chamfer

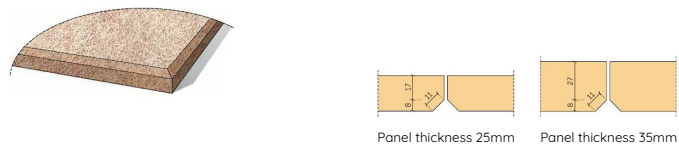

P0-T24 - Standard T24 ceiling profile

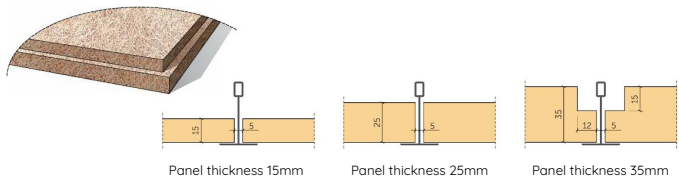

P0G-T24 - Immersed T24 ceiling profile

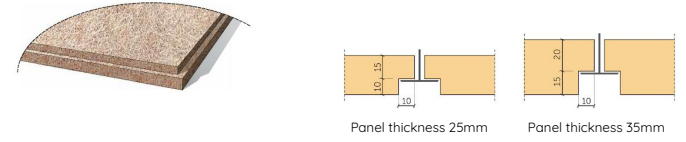

P5G-T24 - Immersed T24 ceiling profile with 5mm chamfer

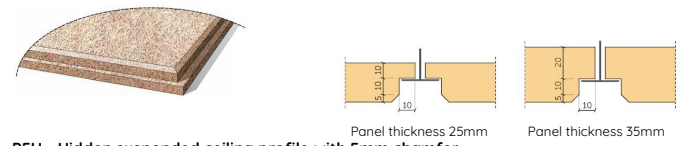

P5H - Hidden suspended ceiling profile with 5mm chamfer

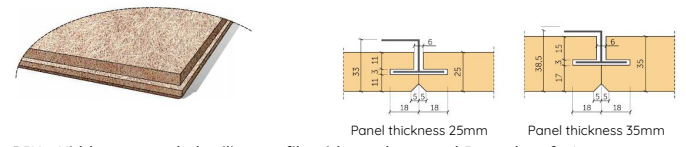

P5H - Hidden suspended ceiling profile with overhang and 5mm chamfer*

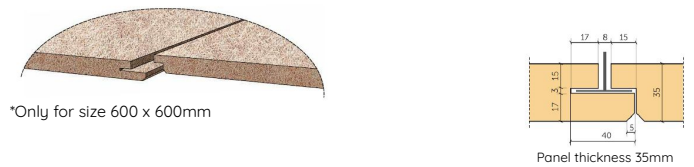

Acusorb Tessere® Panel Edge Profiles					0.5, 1.0, 1.5, 3.0		
Item	Edge detail	Panel thickness (mm)			Frame structure		
		15mm	25mm	35mm	Timber lath	CD profile	T profile
P0		✓	✓	✓	✓	✓	✓
P5		✓	✓	✓	✓	✓	
P11			✓	✓	✓	✓	
P0G			✓	✓			✓
P5G			✓	✓			✓
P5H			✓	✓			✓
P5S				✓			✓



Methods of Installation.

Timber Lath.

Fastening to Timber Lath.

The framework for fastening Acusorb® Tessere Wood Wool panels is constructed of load bearing timber laths, which along with the suspension elements are fastened onto the buildings load bearing structure. Ensure all laths are securely fixed onto the load bearing structure of the building prior to installing the wood wool panels. Placement of suspension elements and loading capacities are shown in the below table.

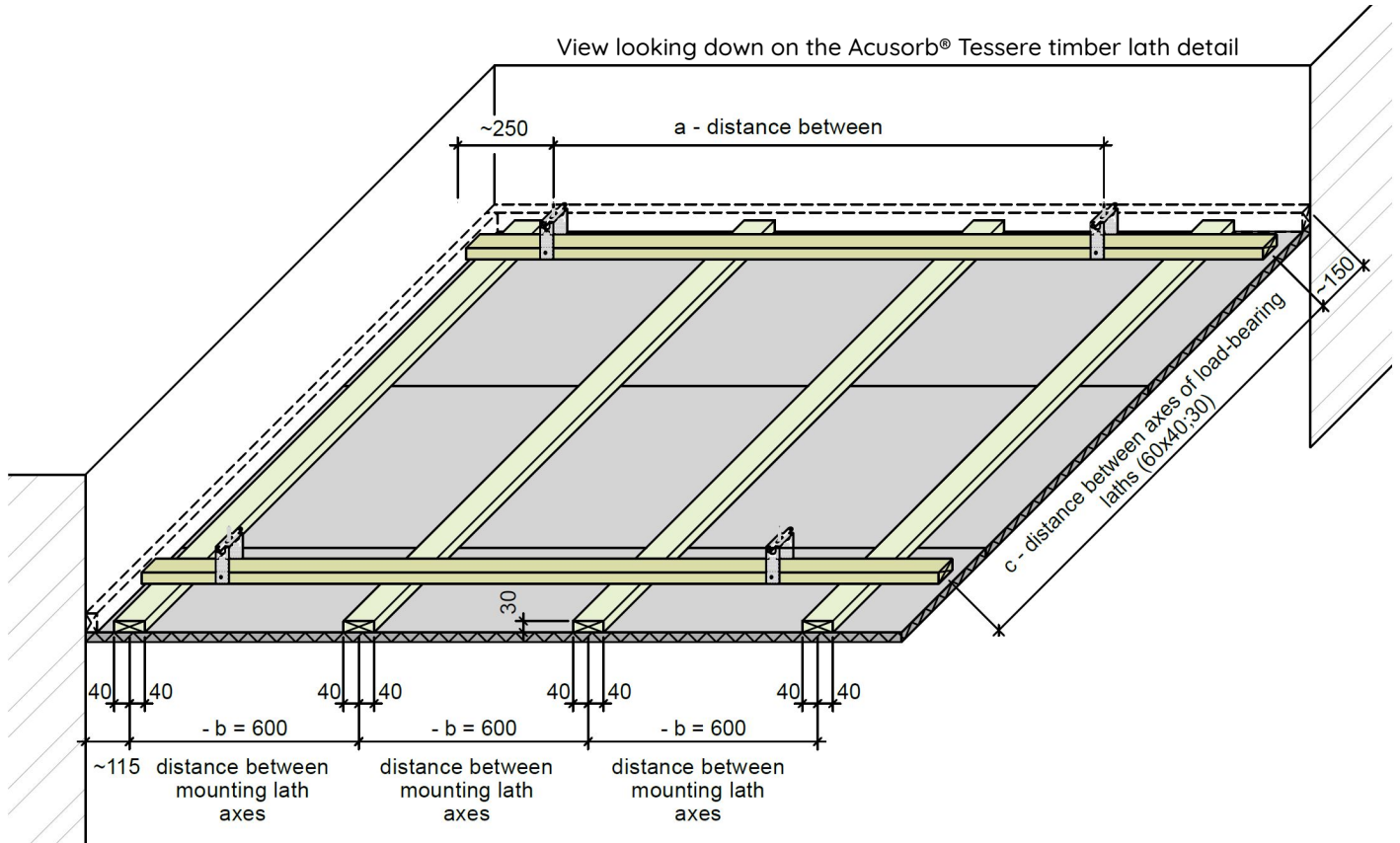

Acusorb Tessere® Mounting Distances of lath framework		0.5, 1.0, 1.5, 3.0		
Load bearing lath cross section 60/40 or 60/30 (mm)	Mounting lath cross section 80/30 (mm)	a = Suspension distance / fastenings Load class kN/m ²		
Distance between axes - c - mm	Distance between axes - b - mm	Up to 0.15	Up to 0.30	Up to 0.50
600mm	600mm	1150mm	900mm	750mm
900mm	600mm	1000mm	800mm	
1000mm	600mm	950mm		
1200mm	600mm	900mm		

Must be suspensions with load resistance of 0.40kN.
Assume load bearing lath cross section of 60 x 40mm or 60 x 30mm depending on calculated loads and the fastening types used.



Methods of Installation.

Timber Lath.

Standard Screw Pattern for Acusorb® Tessere Wood Wool Acoustic

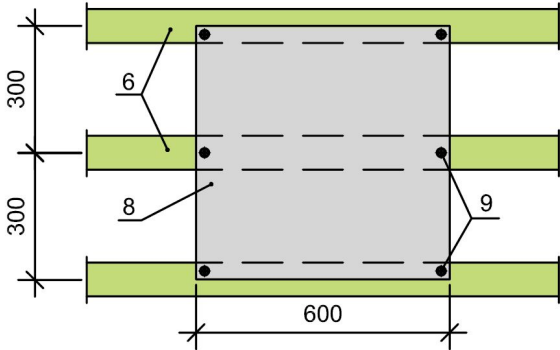

Panel 600 x 600mm, fixed with 6 screws

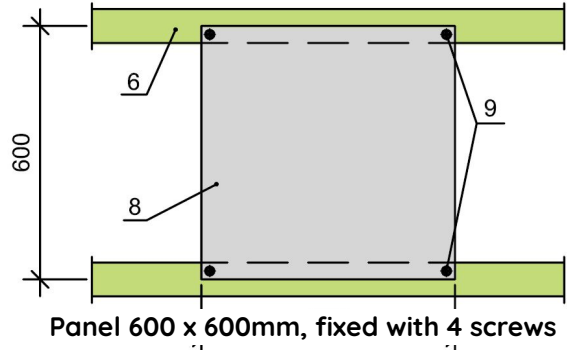

Panel 600 x 600mm, fixed with 4 screws

Panel 600x600 fixation with 4 screws.

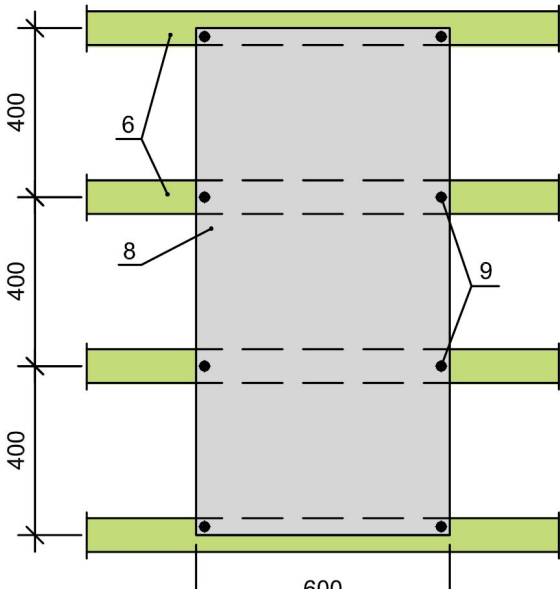

Panel 600 x 1200mm, fixed with 8 screws

Panel 600x1200 fixation with 8 screws.

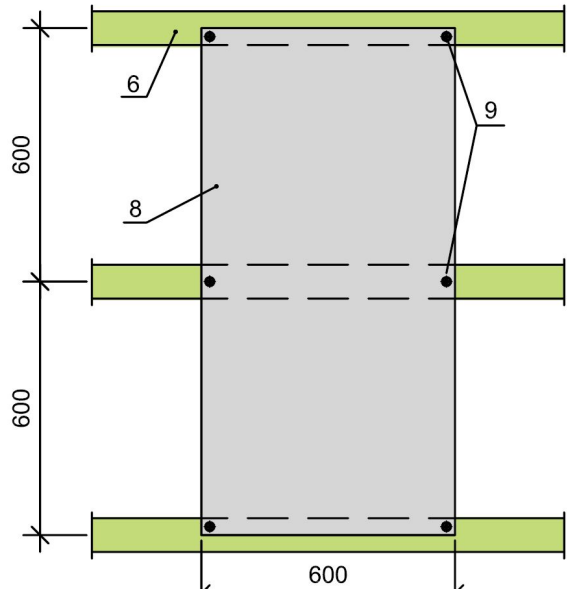

Panel 600 x 1200mm, fixed with 6 screws

Panel 600x1200 fixation with 6 screws.

Key:

- 6 - Mounting lath 80 x 30(h)mm
- 8 - Acusorb® Tessere acoustic panel
- 9 - Galvanised or painted quick construct screw 4.5 (4.65) x 50mm with head Ø 12mm.

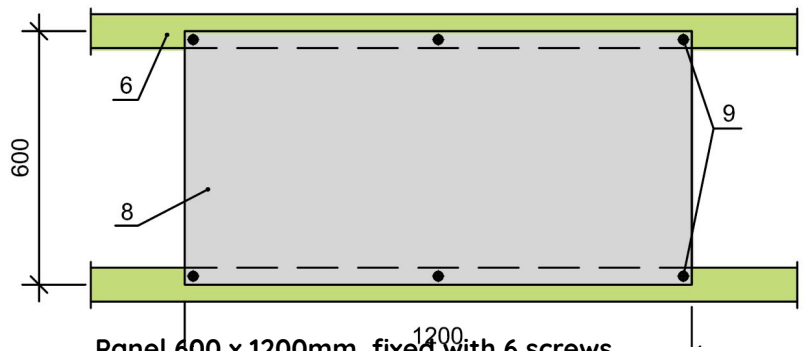

Panel 600 x 1200mm, fixed with 6 screws longitudinally on laths

Panel 600x1200 fastening with 6 screws longitudinally on laths



Methods of Installation.

Impact Resistance.

Fastening of impact resistant Acusorb® Tessere wood wool acoustic ceiling panels with screws, maximum step 315mm (perfect for sports & fitness halls)

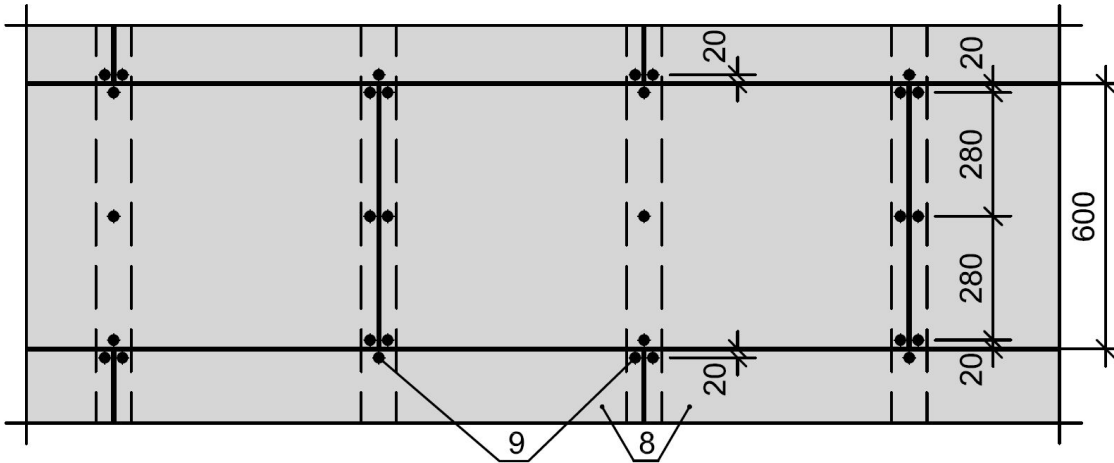

Acusorb® Tessere wood wool acoustic ceiling panels - installation with maintenance hatch.

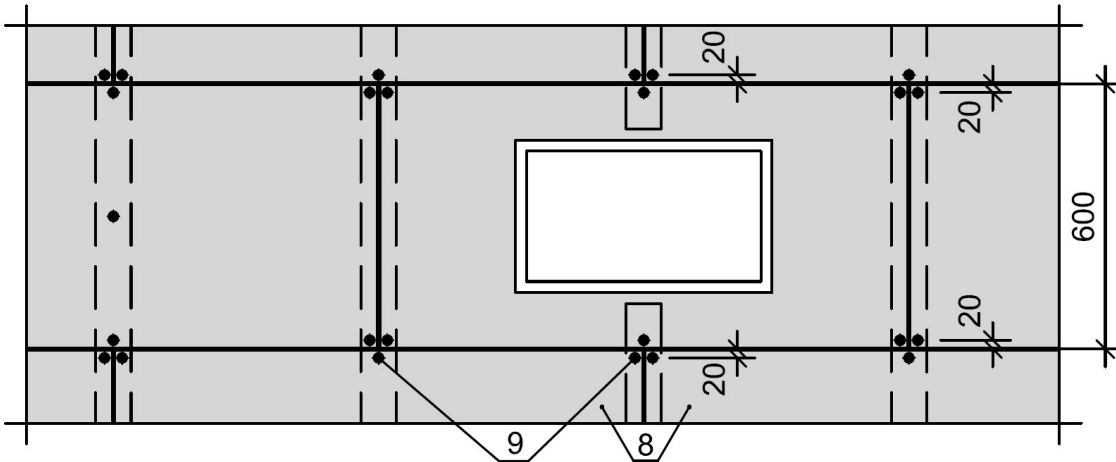

Key:

8 - Acusorb® Tessere acoustic panel.

9 - Galvanised or painted quick construct screw 4.5 (4.65) x 50mm with head \varnothing 12mm.



Methods of Installation.

Nonius Suspension onto Load bearing Soffit.

Fastening an Acusorb® Tessere panel ceiling using a Nonius suspension method with a mineral fibre infill.

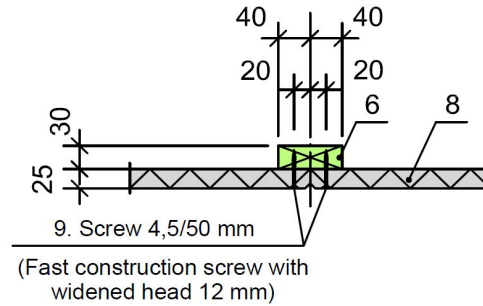
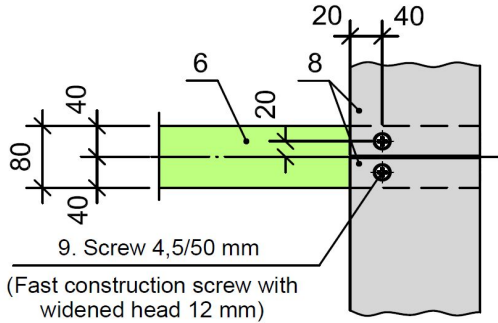

Fastening of mounting lath onto a load bearing soffit

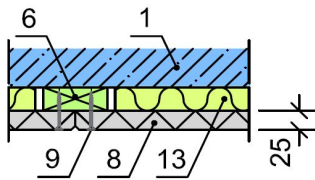

- 1 - Load bearing existing soffit.
- 4 - Screw type.
- 6 - Mounting lath type.
- 8 - Acusorb® Tessere acoustic panel.
- 9 - Galvanised or painted quick construct screw 4.5 (4.65) x 50mm with head Ø 12mm.
- 13 - Mineral fibre.

Direct fix detail

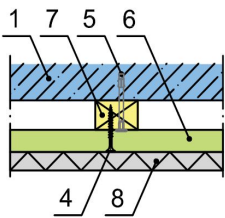

U-Type clamp detail

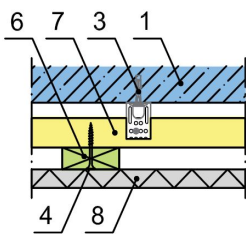

No.3 U-Type clamp with load resistance of 0.40kN

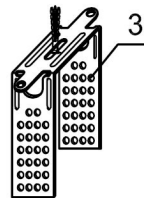

- 1 - Load bearing existing soffit.
- 2 - Quick suspension hanger 0.15kN.
- 3 - U Type clamp 0.40kN.
- 4 - Screw 4.65 x 60mm.
- 5 - Conical anchor M6, for load bearing existing soffit.
- 6 - Mounting lath
- 7 - Load bearing lath of 60 x 30mm OR 60 x 40mm dependent on calculated loads & the fastening type used.
- 8 - Acusorb® Tessere acoustic panel

(a) Quick (Nonius) Suspension detail

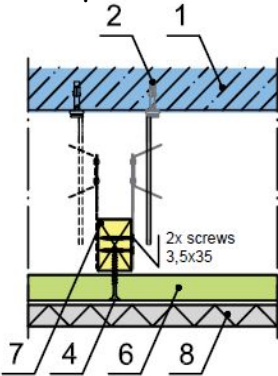

(b) End edge quick Suspension detail

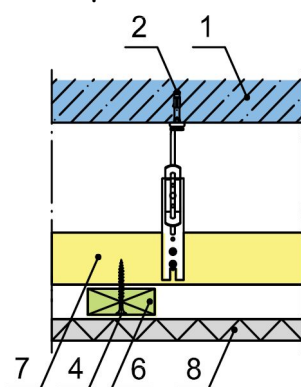

No.2 Nonius hanger with load resistance of 0.40kN



Size of fastening screws depending on panel thickness

Panel thickness	15mm	25mm	35mm
Screw sizes according to DIN7997Z (mm)	4.5 / 35mm	4.5 / 50mm	4.5 / 60mm



Methods of Installation.

Timber Lath.

Fastening to CD Metal Sections.

This framework for fastening Acusorb® Tessere Wood Wool panels is constructed of load bearing CD metal sections, which along with the suspension elements are fastened onto the buildings load bearing structure. Ensure all sections are securely fixed onto the load bearing structure of the building prior to installing the wood wool panels.

Framework is made of perpendicularly arranged CD metal type 60/27/0.6 profiles. Fix onto load bearing structures. Always follow CD metal profile manufacturers guidelines.

CD profile frames are fixed onto load bearing structures using a U-Type suspension, wire suspension or the so called quick suspension method AKA the Nonius type clamp. Placement of suspension elements and loading capacities are shown in the below table.

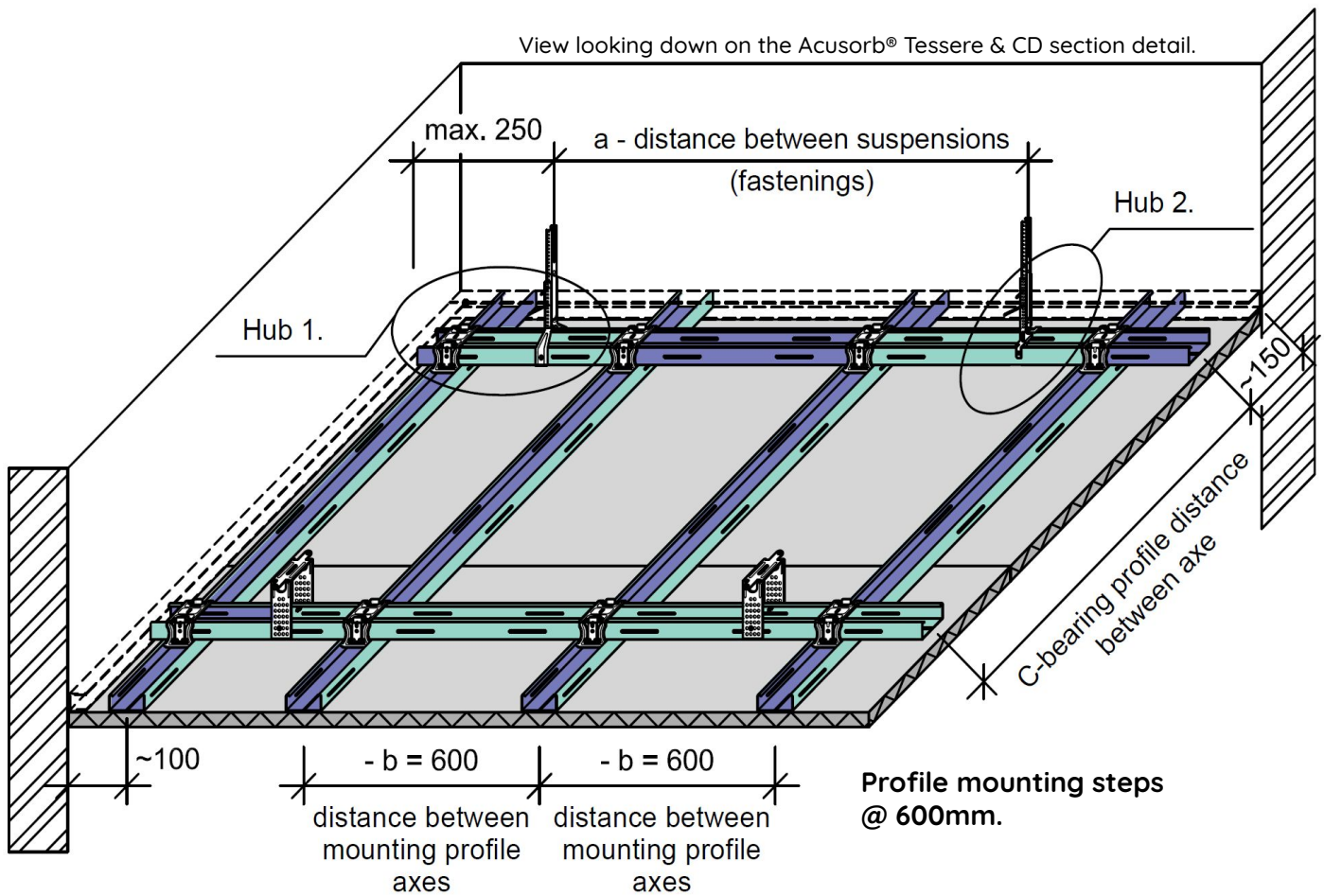

Acusorb Tessere® Mounting Distances of Frame Profiles					0.5, 1.0, 1.5, 3.0	
Load bearing profile 60/27/0.6 (mm)	Mounting profile CD section 60/27/0.6 (mm)	a = Suspension distance / fastenings Load class kN/m ²			Only ceiling under ceiling	
Distance between axes - c - mm	Distance between axes - b - mm	Up to 0.15	Up to 0.30	Up to 0.50	Up to 0.50	
600mm	600mm	1150mm	900mm	750mm	700mm	
900mm	600mm	1000mm	800mm			
1000mm	600mm	950mm	750mm			
1200mm	600mm	900mm				

Must use suspensions with a load bearing capacity of 0.40kN.



Methods of Installation.

Timber Lath.

Standard Screw Pattern for Acusorb® Tessere Wood Wool Acoustic

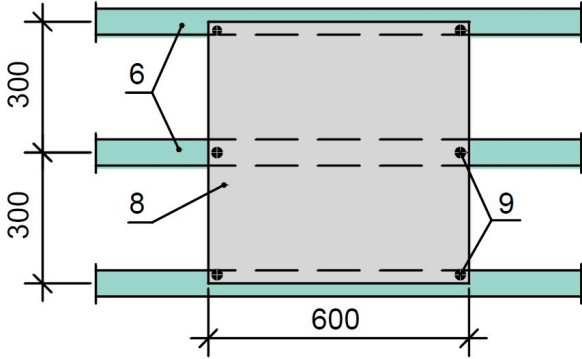

Panel 600 x 600mm, fixed with 6 screws

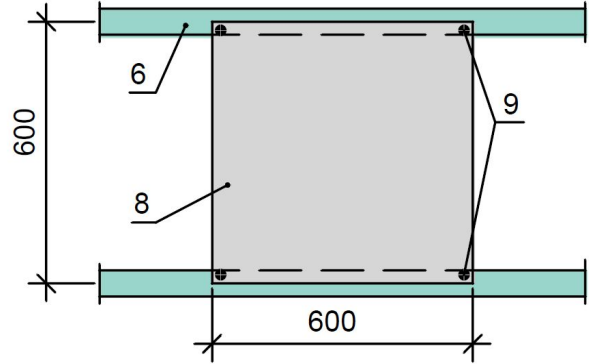

Panel 600 x 600mm, fixed with 4 screws

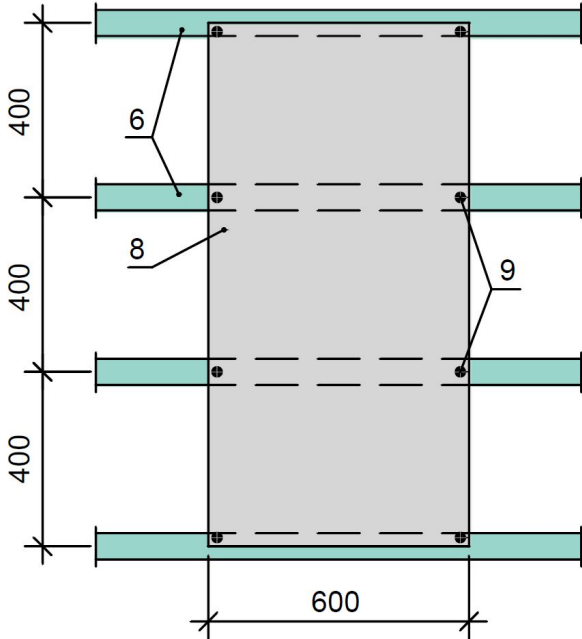

Panel 600 x 1200mm, fixed with 8 screws

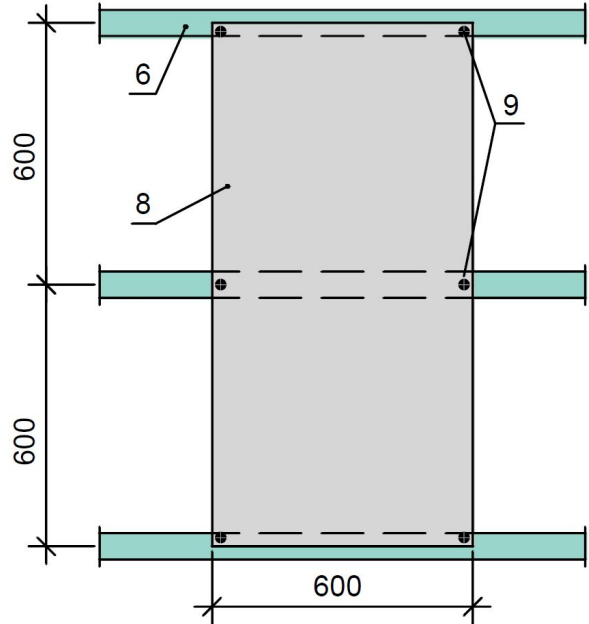

Panel 600 x 1200mm, fixed with 6 screws

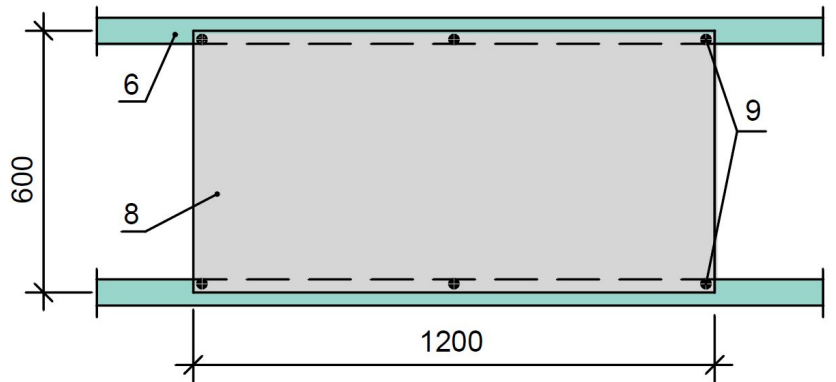
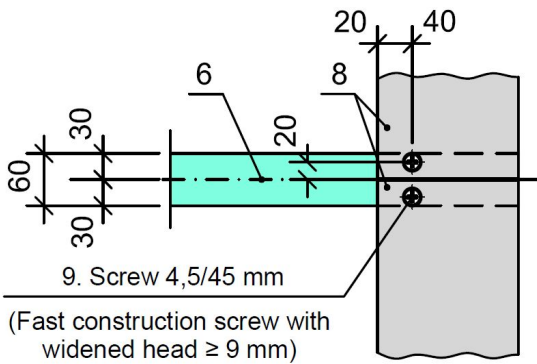

Panel 600 x 1200mm, fixed with 6 screws longitudinally on laths

A connection seam should always be formed under the CD mounting profile.

Key:

6 - Mounting CD profile 60 x 27(h) x 0.6mm

8 - Acusorb® Tessere acoustic panel

9 - Galvanised or painted quick construct screw 4.5 (4.65) x 50mm with head $\varnothing \geq 9$ mm.



Methods of Installation.

CD Suspension Methods onto a Load Bearing Soffit.

Fastening of CD Mounting Sections onto a Load Bearing Slab Structure.

A CD mounting profile 60/27/0.6mm should be attached onto a load bearing profile 60/27/0.6mm using a 60 x 27mm CD profile cross connector. The CD profile frame is fixed onto a load bearing slab structure using 'quick suspension' method, either a U-Type clamp or a Nonius type fastening.

Direct Fastening No.3. U-Type clamp with a load resistance of 0.40kN

A CD mounting profile 60/27/0.6 mm is attached onto a CD load-bearing profile 60/27/0.6 mm using a 60x27 cross-connector of CD profile.

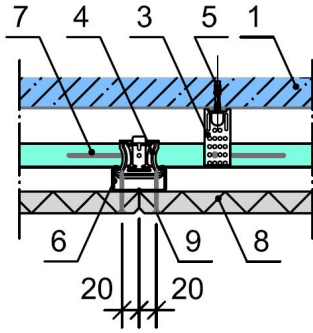

Joint between longitudinal edges.

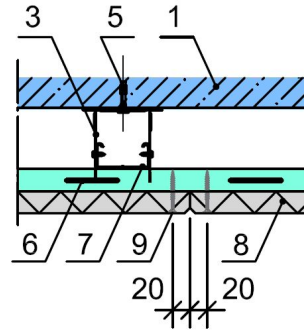
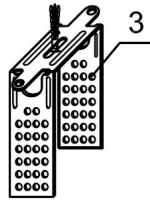

Joint between end edges.

Suspended Fastening No.2. Nonius suspension with anchor fastening on to metal sections

A 0,25 kN (estimated load-bearing capacity $0.25 \times 0.6 = 0.15\text{kN}$)

Maximum step of quick suspension 600 mm.

Maximum distance from the wall for quick suspension 190 mm.

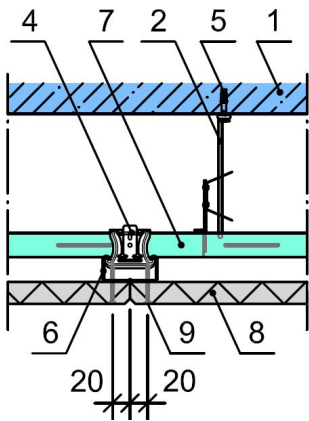

Joint between longitudinal edges.

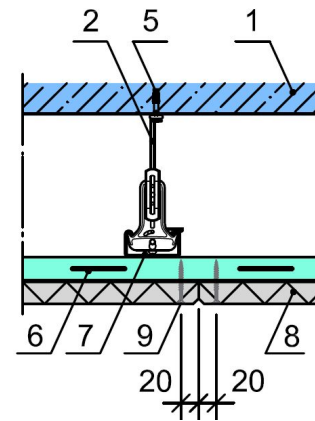
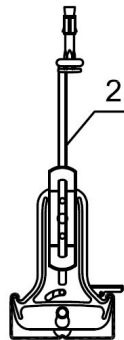

Joint between end edges.

Key:

1 - Load-bearing slab structure.

2 - Quick suspension with anchor fixation - 0.15 kN

3 - U-type clamp 0.40 kN.

4 - Cross connector for CD profile 60 x 27 x 0.6mm (before mounting fold down by 90°). Alternative: 2x anchor angles for CD profile 60 x 27 x 0.6mm (fold down before mounting).

5 - Conical anchor M6.

6 - Mounting CD profile 60 x 27 x 0.6mm.

7 - Load-bearing CD profile 60 x 27 x 0.6mm.

8 - Acusorb® Tessere acoustic panel

9 - Galvanised or painted quick construct screw 4.5 (4.65) x 50mm with head $\varnothing \geq 9\text{mm}$.



Methods of Installation.

Pattern variations and guidelines for walls.

Typical Guidelines for the Installation of Acusorb® Tessere acoustic panels.

Typical patterns of Tessere acoustic panels.

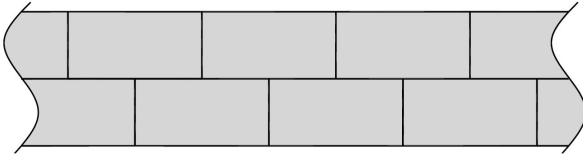

Panel size 600 x 1200mm.

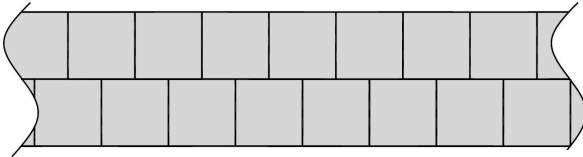

Panel size 600 x 600mm.

Suspended ceilings with visible T-sections.

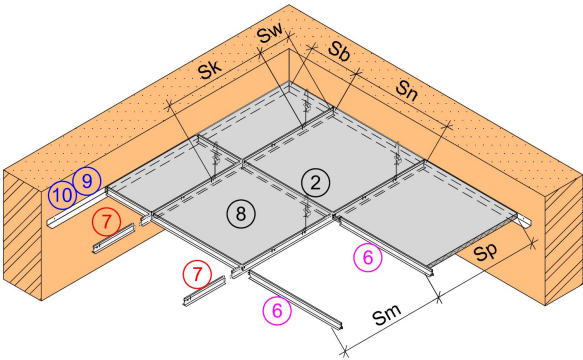

T-profile suspended ceiling grid frames are offered by a number of manufacturers. The four (4) key elements are as follows:

- 7 - Main runners.
- 6 - Intermediates
- 9 - Perimeter angles
- 2 - Suspension drop rods or adjustable wire.

For suspended ceilings the panels are made of special size – width 595 ±1 mm, length 1195, 595 ±1 mm. Other technical parameters of panels are stated on page 12, Profile Specifications. The ceiling frame manufacturer declares the bearing capacity of the frame profile according to the standard BS EN 13964. The T 24 profile step is defined depending on the structural load provided the permissible flexure of 1/500 l. The step of the load-bearing profile laths of Tessere panel ceilings – 1200 or 600 mm, distance between mounting laths (axes) – 600 mm. Suspension distances are provided in table below. The procedure and methods of assembling the ceiling frame are determined by the manufacturer of the ceiling grid system.

Details on screw fixings below.

Size of fastening screws depending on panel thickness		
Dimensions (mm)		Panel thickness (mm)
Length	Diameter Ø	
35mm	4.65mm	15mm
50mm	4.65mm	25mm
60mm	4.65mm	35mm

NB - Indicative values for a ceiling structure, using steel CD profiles 27/60/0.6 mm

Quick guide to “screw consumption”		
Panel format dimensions (mm)	Screw consumption, pcs./m ²	
	600 x 600mm	600 x 1200mm
Standard screw connection scheme. Panel thickness 25 and 35 mm.	12	9
Standard screw connection scheme. Panel thickness 15 mm.	23	14

NB - To mount **Acusorb® Tessere** acoustic panels in a building with elevated humidity (e.g., swimming pools) OR outdoors, then galvanised or painted quick construction screws with a conical head of Ø ≥ 9mm must be used.

Load kN/m ²	0.12	0.15		0.20		0.25
Step between load-bearing profile laths Sn, mm	1200	1200	600	600	600	600
Step between suspensions Sk, mm	≤ 1000	≤ 900	≤ 1100	≤ 1000	≤ 1000	≤ 1000
Step between suspension and wall Sw, mm	≤ 250	≤ 250	≤ 250	≤ 200	≤ 200	≤ 200
Step between cross profile laths Sm, mm	600	600	600	600	1200	600

The size of Sb and Sp start and end panels and the step for profile laths are changed depending on the room size. Max. distance of a profile lath from wall 600 mm. Note. With higher loads, the step between the suspensions must be accordingly reduced.



Methods of Installation.

Wall mounting variations, timber lath, and guidelines.

Typical Guidelines wall mounting of Acusorb® Tessere acoustic panels.

This timber lath frame structure is constructed of vertically arranged planks sized 80 x 30mm. This structure is ideal if it is **not** necessary to level out the vertical or horizontal planes of the wall or to set up substantial extra sound and heat insulation.

Vertical wood lath fastening onto a load bearing wall.

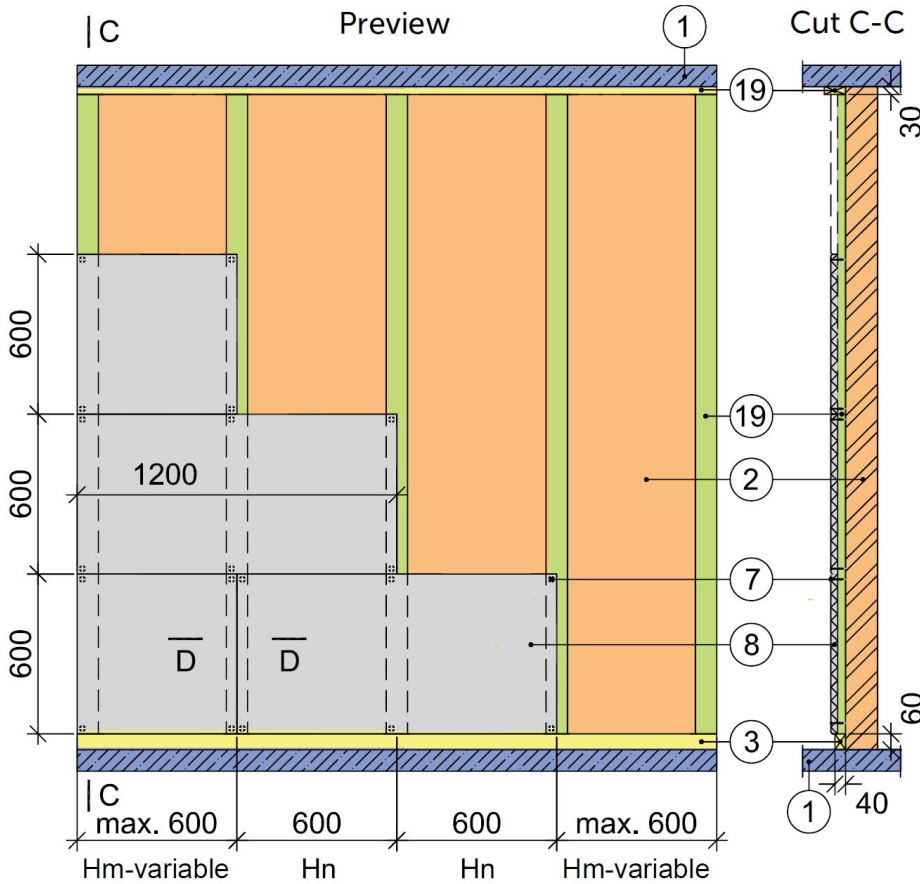

Section D-D

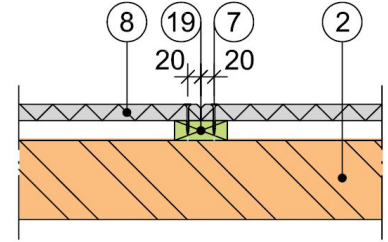

Wood lathing fastening on to a load-bearing wall structure

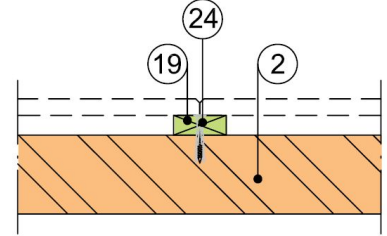

Key:

- 1 - Load-bearing slab structure or foundation.
- 2 - Wall structure.
- 3 - Crown lath (tanalised) 40 x 60(h)mm.
- 7 - Wood screw
- 8 - Acusorb® Tessere acoustic panel.
- 19 - Timber lath (tanalised) 30 x 80(h)mm (max 50 x 100(h)mm)
- 24 - Lath fastening rawl plug, step 0.8m - 1.0m

Approximate material consumption for 10m² (2500 x 4000 mm) wall cladding.

Item	Denomination	Fastening Element	Unit of Measure	Quantity for 10m ² Wall*
1	3.19	Crown lath 60 x 40mm Timber lath 30 x 80mm	m ³	0.06
2	24	Lath fastening screw plugs 8 x 80mm*	pc	40
3	8	Acusorb® Tessere wood wool panels	m ²	10
4	7	Acusorb® panel screws	pc	90
5		Labour	h	10

All calculations in the table are approximate values.

* 2500 x 5000mm wall used for calculations. * Size and type according to load-bearing wall structure.



Methods of Installation.

Wall mounting variations, timber lath, and guidelines.

Typical Guidelines wall mounting of Acusorb® Tessere acoustic panels.

This timber lath frame structure is constructed of horizontally arranged planks sized 80 x 30mm. This structure is ideal if it is **not** necessary to level out the vertical or horizontal planes of the wall or to set up substantial extra sound and heat insulation.

Horizontal wood lath fastening onto a load bearing wall.

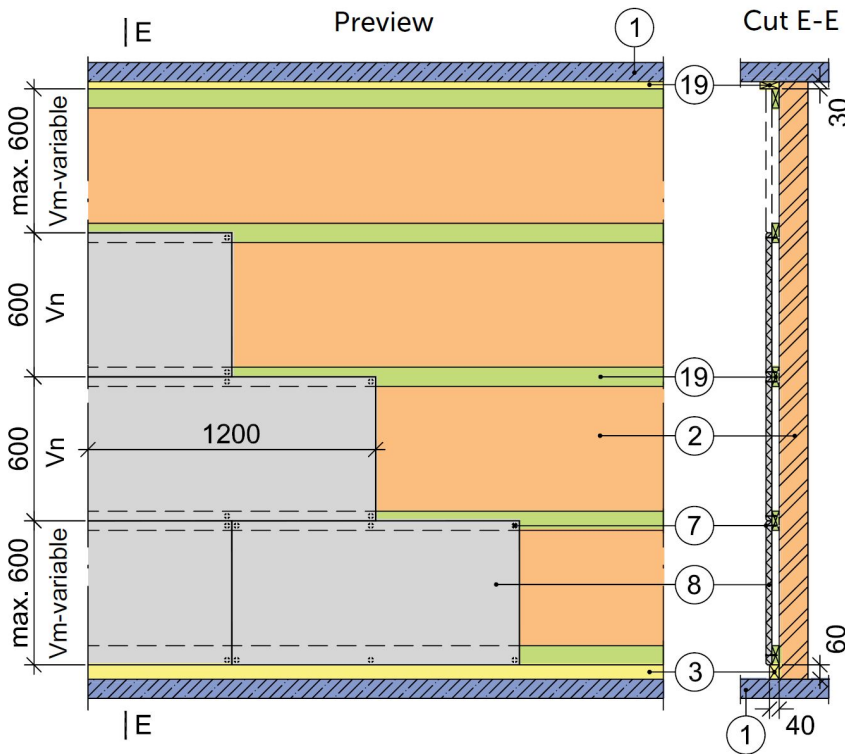

Key:

- 1 - Load-bearing slab structure or foundation.
- 2 - Wall structure.
- 3 - Crown lath (tanalised) 40 x 60(h)mm.
- 7 - Wood screw
- 8 - Acusorb® Tessere acoustic panel.
- 19 - Timber lath (tanalised) 30 x 80(h)mm (max 50 x 100(h)mm)
- 24 - Lath fastening rawl plug, step 0.8m - 1.0m

Approximate material consumption for 10m² (2500 x 4000 mm) wall cladding.

Item	Denomination	Fastening Element	Unit of Measure	Quantity for 10m ² Wall*
1	3.19	Crown lath 60 x 40mm Timber lath 30 x 80mm	m ³	0.07
2	24	Lath fastening screw plugs 8 x 80mm*	pc	42
3	8	Acusorb® Tessere wood wool panels	m ²	10
4	7	Acusorb® panel screws	pc	90
5		Labour	h	11

All calculations in the table are approximate values.
* 2500 x 5000mm wall used for calculations. * Size and type according to load-bearing wall structure.



Methods of Installation.

Wall mounting variations, timber lath, and guidelines.

Double wood lath frame. Interior wall finishing with Acusorb® Tessere

The double frame can be chosen if it is necessary to straighten any wall plane deviations and can be used to create additional sound or heat insulation.

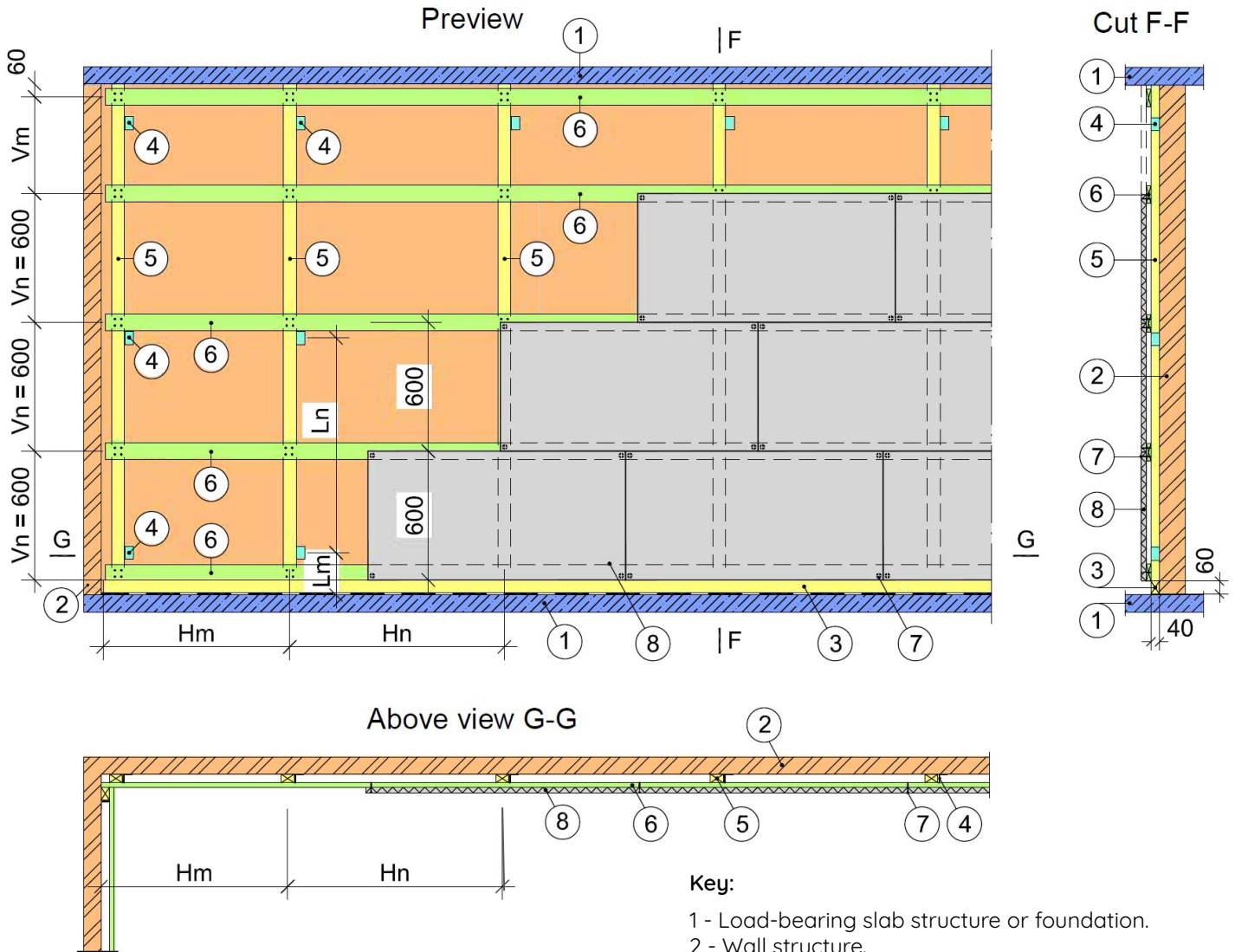

Recommended step spacings between laths.

Acusorb® Tessere panel thickness	25mm	35mm	50mm
Step between load-bearing laths Hm mm	≤ 1000	≤ 800	≤ 600
Step between load-bearing laths Hn mm	≤ 1000	≤ 800	≤ 600
Step between mounting laths Vm mm	≤ 600	≤ 600	≤ 600
Step between mounting laths (fixed) Vn mm	600	600	600
Step between fastening elements Lm mm	≤ 250	≤ 250	≤ 250
Step between fastening elements Ln mm	≤ 1200	≤ 1000	≤ 800



Methods of Installation.

Wall mounting variations, CD metal profiles, and guidelines.

Acusorb® Tessere fastening on a CD metal profile construction.

Wood wool panels are fastened on to a metal profile frame using a special, horizontally arranged profile (pos. 12 and 13), which is fixed on to the load-bearing profile (pos. 11).

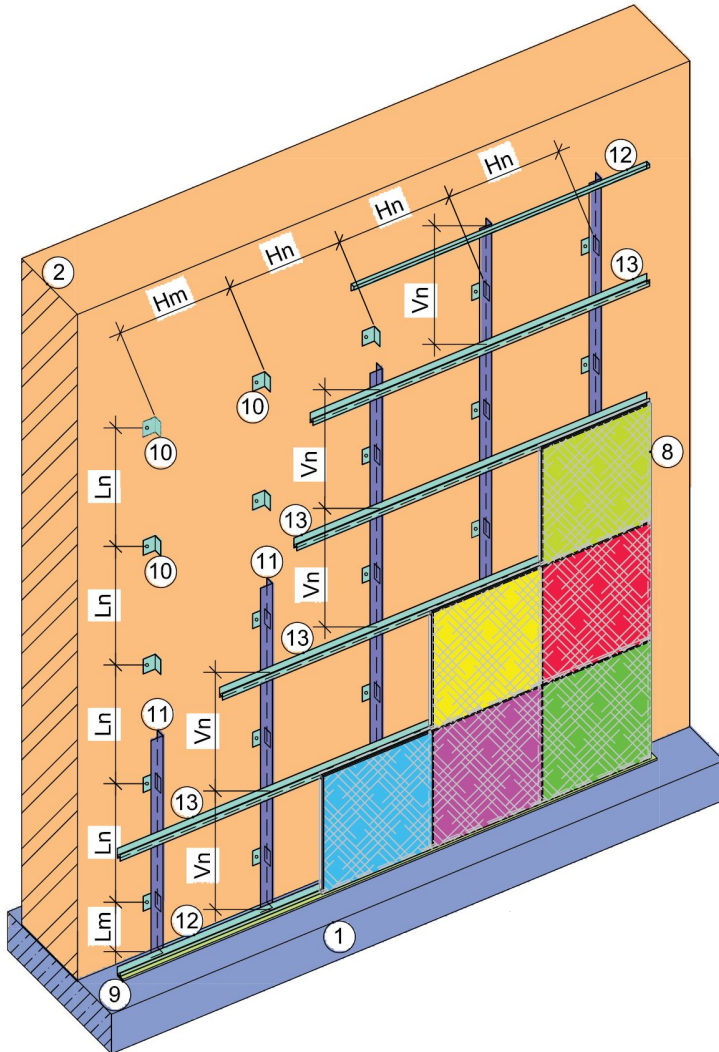

Key:

- 1 - Load-bearing slab structure or foundation.
- 2 - Wall structure.
- 3 - Crown lath (tanalised) 40 x 60(h)mm.
- 4 - Load-bearing lath fastening angle L40 x 60 x 1.5mm.
- 5 - Wooden rectangular timber 50 x 80mm.
- 7 - Wood screw.
- 8 - Acusorb® Tessere acoustic panel.
- 9 - Levelling lath 21 (h)x40 mm.
- 10 - Load-bearing profile fastening angle L40 x 60 x 1.5mm
- 11 - Load-bearing profile L60/40/1.8 mm.
- 12 - Perimeter profile (horizontal).
- 13 - Assembly profile.
- 14 - Perimeter angle 21/21.
- 15 - CD-profile 60/27/0.6.
- 16 - U-type clamp/U-type clamp fastening wood screw- 4.5 x 45mm
- 17 - Plasterboard panel 12.5 mm.
- 18 - Quick construction screw.
- 22 - Impact sound insulating support, e.g. PhonoMat USF- 730-10mm
- 23 - Mineral fibre.
- 24 - Lathing fastening screw plug, step 0.8-1.0 m.

Recommended step spacings between laths.

Acusorb® Tessere panel thickness	25mm	35mm	50mm
Step between load-bearing CD sections Hm mm	≤ 1000	≤ 800	≤ 600
Step between load-bearing CD sections Hn mm	≤ 1000	≤ 800	≤ 600
Step between mounting CD sections (fixed) Vn mm	600	600	600
Step between fastening elements Lm mm	≤ 250	≤ 250	≤ 250
Step between fastening elements Ln mm	≤ 1200	≤ 1000	≤ 800

Note. The building project must take into account the bearing capacity of the specific wall and the used screw plugs accordingly, specifying the sizes provided in the table.



Methods of Installation.

Wall mounting variations, CD metal profiles, and guidelines.

Acusorb® Tessere fastening on a CD metal profile construction.

Wood wool panels are fastened to a metal profile frame using a special, horizontally arranged profile (pos. 12 and 13), which is fixed on to the load-bearing profile (pos. 11).

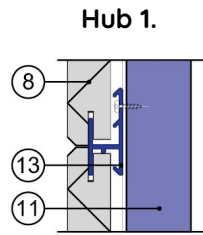
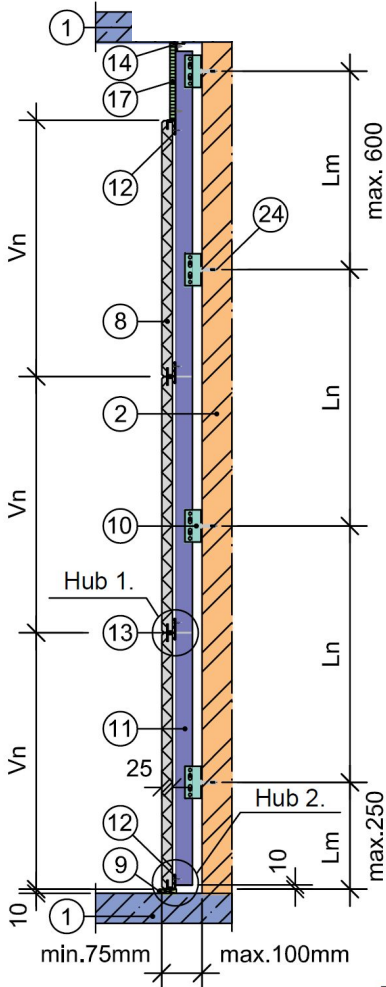

A horizontal superior view of the corner finishing solution with a plasterboard frame.

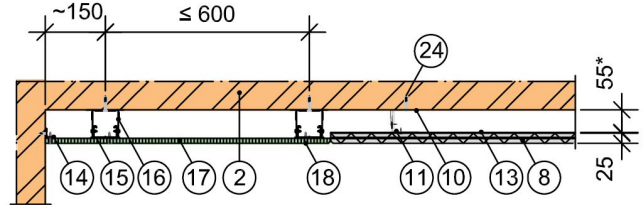

Note: The perimeter plasterboard mill is intended for design purposes in order to highlight the Acusorb® Tessere panel.

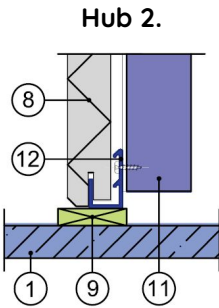

A horizontal superior view of the corner finishing solution with a shadow joint.

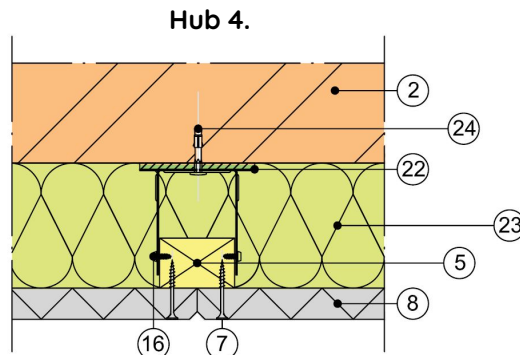
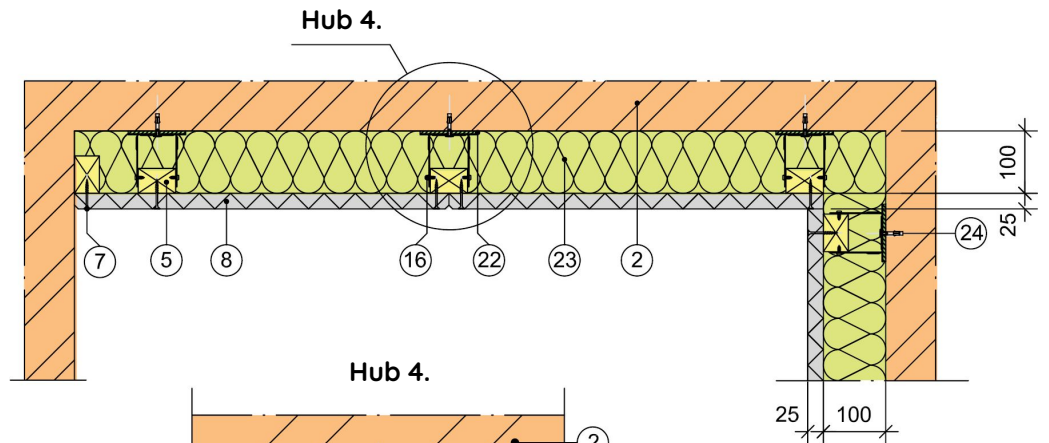
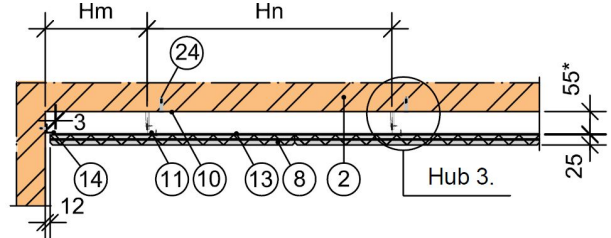

Fastening with a moving support and impact noise insulating base (pos. 22).

The structure allows levelling out the existing wall and ensures impact noise insulation.



Methods of Installation.

Demountable variations, T24 metal profiles, and guidelines.

Acusorb® Tessere baffle fastening on a T24 metal profile construction.

Wood wool baffles are fastened on to a metal T24 grid profile frame using a fixed rod system, adjustable drop wire or a lower profile L (pos. 3) shaped angle bracket to minimise drop (pos. 1 and 2), all should be fixed on to a load-bearing substrate.

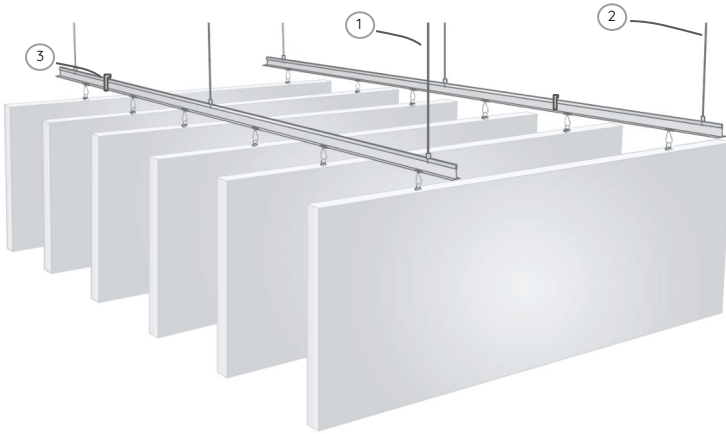

Standard T24 main runner.

Twist clip with eye.

Safety Hook.

Spiral anchor.

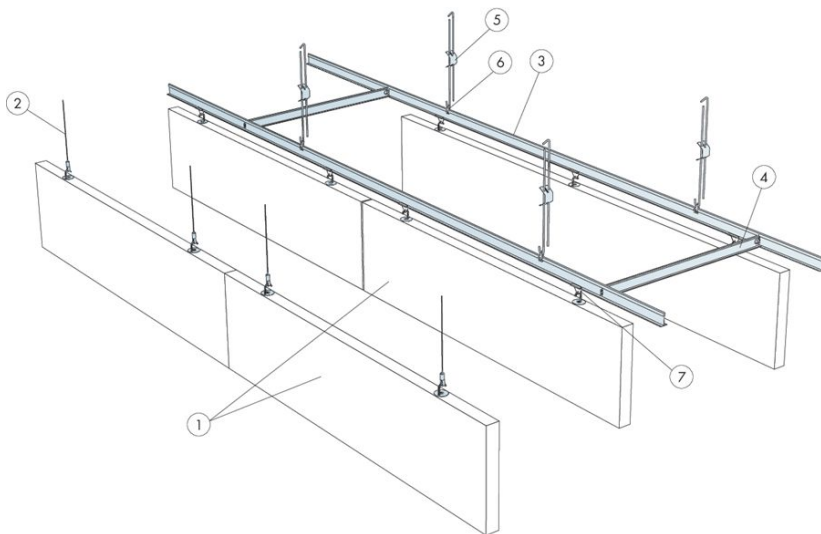

Key:

- 1 - Tessere baffle.
- 2 - Adjustable wire hanger (Alt 1) 2-3 per panel.
- 3 - T24 Main runner installed @ 600mm ctrs (Alt 2) 1.7m/m².
- 4 - T24 cross tee connector L=600mm, installed @ 1800mm ctrs (Alt 2) 0.6m/m².
- 5 - Rigid adjustable hanger with eye, c1200 (Alt 2) 1.4/m².
- 6 - Adjustable hanger clip (Alt 2) 1.4/m².
- 7 - Corkscrew anchor 2-3 per panel.

Recommended minimum distance between baffles for optimum acoustic performance

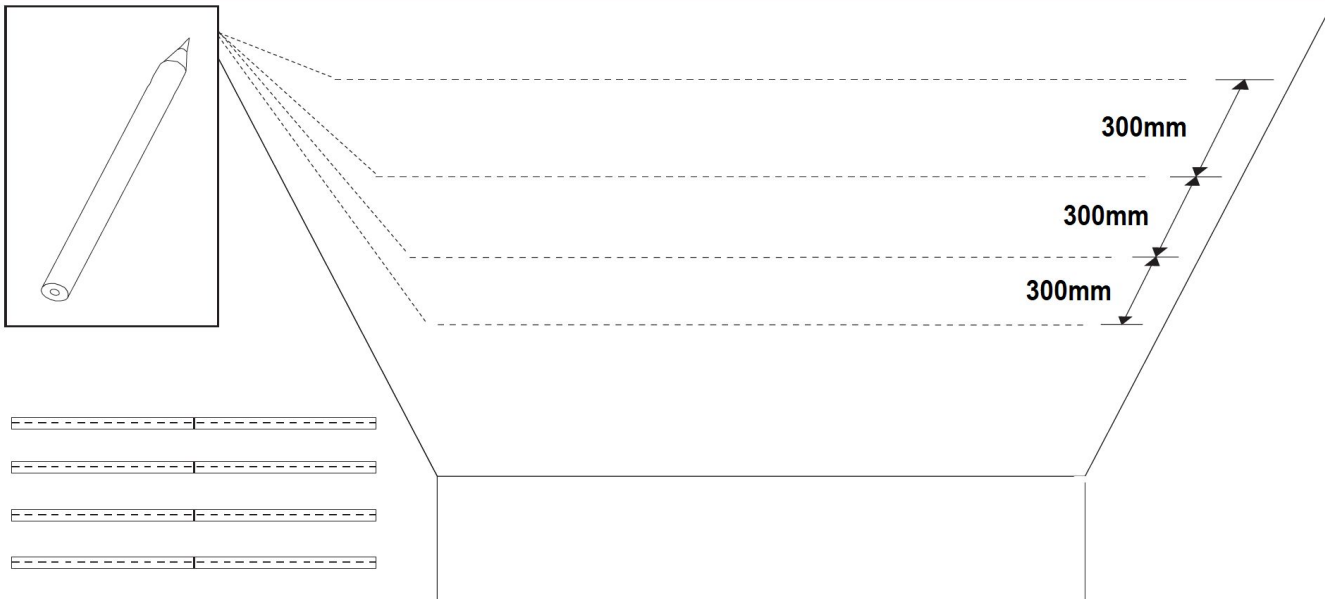



Before Installation.

Instructions for storage and preparation of Acusorb® Tessere panels before installing. For more detailed information see acuphon.co.uk or contact our technical department.

Primary inspection

Upon delivery, check the panels for accordance with the order and for any visible defects. If you find any inadequacy, immediately contact the producer or vendor as the defects reported after installing don't meet the warranty.

Storage conditions

Acusorb® Tessere Decorative / Acoustic panels for indoor use are made from high-quality wood wool and cement.

The fireproof material has great acoustic and thermal insulation capacities, and is perfectly suitable for the widest range of interior solutions.

The panels maintain their properties at the temperature $+23 (+/- 2) ^\circ\text{C}$ and the relative humidity of 50% ($+/- 5\%$). To ensure the best properties, the panels should be allowed to adopt the ambient conditions. The optimal period for acclimatization is one to two weeks.

If stored outdoors, the panels can be protected with a cover of tarpaulin or similar material. The material should not be kept outdoors for long periods of time, it should definitely not be stored directly on the ground.

When storing the panels indoors, the packaging material should be removed to avoid accumulation of condensation and to ensure better acclimatisation. It is recommended not to expose the material to direct heat, humidity and dust.

Before installing the panels should be stored horizontally, on a flat and stable foundation, as pallets or a platform.

Best conditions for acclimatisation are achieved if the material is kept in layers, separated with slats. The material has very good physical indicators, it maintains the same humidity and temperature, as the surrounding environment, for example wooden floors.

It is not recommended to start installing of the panels before the construction works are finished or just before starting of the heating system.

The panels have undergone a full drying cycle during the production process, but there can be accumulation of humidity during the transportation and storing, so there should be an acclimatization period to assure the best resistance. Yet the environmentally caused mass fluctuations of the material cannot cause it to expand or shrink, and do not influence the other parts of the building





After Installation.

Instructions for care and maintenance of Acusorb® Tessere panels after installing. For more detailed information see acuphon.co.uk or contact our technical department.

Few weeks after finishing installing the panels small dust particles may be present, due to the mounting process. To get rid of the dust use a vacuum cleaner with a brush nozzle.

If the panels are dirty or abraded during the installation, clean the surface with a damp cloth. In case the mounting works have caused surface defects, process the panel with a fine grade sandpaper.

If necessary, the colouring of the decorative/acoustic panels can be restored with a spray paint. Choose the corresponding colour and make sure to shake the spray-can for at least a minute prior to spraying.

Operation and maintenance

Once installed, the Acusorb® Tessere panels do not require any additional maintenance. The surface cleaning can be done together with the general cleaning of the premises.

General cleaning is easy and can be carried out with a vacuum cleaner with a brush nozzle. If additional cleaning is needed, use a damp cloth.

The colouring can be refreshed using a spray paint or a roller with long bristles. Applying water-based colour does not affect the the sound absorption properties of the panels.

Acusorb® Tessere decorative / acoustic panels for indoor use are made from high-quality wood wool and cement.

The fireproof material has fantastic acoustic and thermal insulation characteristics, and is perfectly suitable for a wide range of interior solutions.

The Acusorb® Tessere panels have a long work-life, up to 100 years. The robust and durable material does not change when exposed to humidity, the panels are mold-safe and vermin-free.

Due to the contained cement the panels retain their shape and do not change under humidity. The wood wool strands hold it all together ensuring easy and convenient handling and mounting.





Acoustic Wood Wool Screw.

Acusorb® Tessere typical fastening screws.

Wood wool panels are fastened on to a metal profile frame using a special, horizontally arranged profile (pos. 12 and 13), which is fixed on to the load-bearing profile (pos. 11).

TRABO FH 4.65 X L #1S TX20

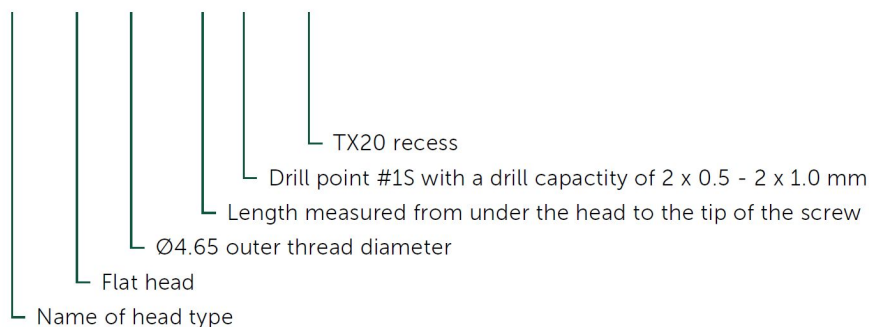

Acusorb® Tessere typical fastening screws description.

Art.no.	Item name	Thread (mm)	Length (mm)	Shaft (mm)	Drill point	Drill cap (mm)	Head (mm)	Unit
17770	TRABO FH 4.65 x 45 #1S TX20	Ø4.65	45mm	12mm	#1S	0.5 - 1.5	Ø13.5 TX20	250

Advantages.

- Suitable for fastening of acoustic panels to steel or wood.
- Large head for better load distribution.
- Specially designed pattern on the head for better concealing.
- Surface treated with ZYTEC™ GX for optimal corrosion protection.
- Available in more than 500 colours (Qualicoat certified facade quality powder)

Technical data	
Head	Ø13.8mm flat head with TX20 recess
Diameter	Ø4.65mm
Shaft	12mm
Drill point	#1S
Drill capacity	0.5 - 1.5mm (Steel S280GD)
Material	Hardened steel
Surface treatment	ZYTEC™ GX
Corrosive category	C3 (high) according to EN ISO 12944-2

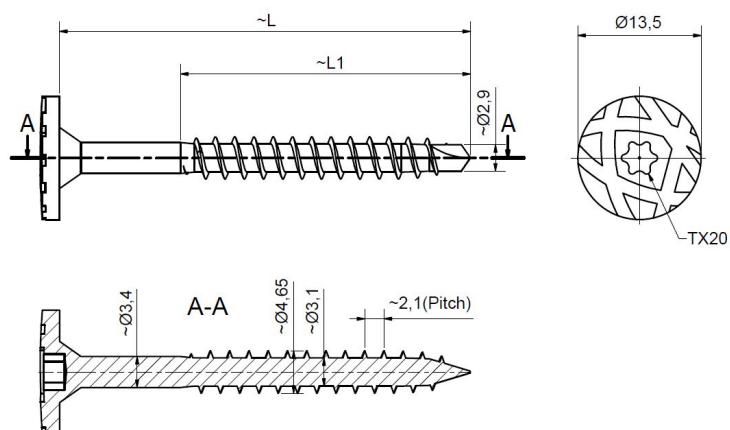



Acoustic Wood Wool Screw.

Design resistance.

The design resistance of the screw is determined in accordance with EN 1993-1-3:2006 + AC:2009 and EN 1995-1-1:2004 + AC:2006 + A1:2008 + A2:2014.

The resistance when loaded in tension, N_{Rd} , appears from the table on the right and is the minimum value of the pull-out resistance of the supporting object and the tension resistance of the screw. Thus, the pull-through resistance of the fixed object is not taken into account.

The theoretical values must be considered indicative since the conditions of the construction site may vary. Practical tests of the specific application are recommended for verification of the listed values

Assumptions.

Fixed object.

- Steel S280GD - BS EN 10346.
- Supporting object: Steel S280GD - BS EN 10346.
- Supporting object: Structural wood, C24.
- Density, $\rho_k = 350 \text{ kg/m}^3$.
- Withdrawal parameter, $f_{ax,k} = 11 \text{ N/mm}^2$.

L = Length of the screw [mm]

t_I = Thickness of the fixed object [mm]

t_{II} = Thickness of the supporting object [mm]

All resistances are stated in kN (1 kN \approx 100kg)

Safety factor: $\gamma_M = 1.35$, $k_{mod} = 0.90$

Design resistance when loaded in tension, N_{Rd} [kN] - Steel support	
t_{II} \ L	45
0.50	0.28
0.63	0.35
0.73	0.42
0.88	0.49
1.00	0.56
1.25	0.70
1.50	0.57

Design resistance when loaded in tension, N_{Rd} [kN] - Wooden support	
t_{II} \ L	45
5	1.00
10	1.00
15	0.91
20	0.74
25	0.57





Tessuto Technical Specification.

1. Product Overview

Install with the following components:

Acusorb® Tessere Solu panels in the size of.....mm long Xmm wide Xshape.

Acusorb® Tessere Geo panels in the size of.....mm long Xmm wide Xshape.

Acusorb® Tessere Ceiling Baffle in the size of.....mm long Xmm wide Xshape.

2. Finish

Colour to be chosen from our standard colourway range: RAL - Colour.....

NCS - Colour.....

3. Tolerance

Panel cutting tolerance: +/- 2mm.

4. Fire Performance

Reaction to fire (BS EN 13501-1:2007) A2-s1, d0. RequiredYes/No

Reaction to fire (BS EN 13501-1:2007) B-s1, d0. Required.....Yes/No

5. Nominal Density & Weight

Acusorb® Tessere core board is 370kg/m³ - 830kg/m³ and the finished product weight is 7.5kg/m² - 18.5kg/m². See technical specifications

6. Installation

Install Acusorb® Tessere Wood Wool acoustic wall panels, ceiling panels & baffles in client specific locations, level and in alignment with other product types. Comply with manufacturer's written instructions for installation of panels using type of fixing accessories indicated as above as recommended by the manufacturer.

7. Storage, Delivery & Handling

Protect Acusorb® Tessere Wood Wool acoustic panels from excessive moisture when storing, and handling. Keep panels flat at all times.

8. Cleaning

After completion of installation remove all dust.

Always remove surplus material, debris and rubbish resulting from panel installation. On completion of works leave areas of installation neat and tidy.

9. Supplier

Acusorb® Tessere Wood Wool acoustic panels supplied by:

Acuphon Ltd, Orchard House, Fuller Street, Ruddington, Nottinghamshire, NG11 6HU, United Kingdom.

Tel: 01904 900 194 Email: sales@acuphon.co.uk Web: www.acuphon.co.uk