

Special Features

- ▲ STAINLESS STEEL CONSTRUCTION
- ▲ VANDAL RESISTANT DESIGN
- ▲ EXTREMELY DURABLE AND ROBUST
- ▲ CONFIGURATIONS TO SUIT ANY LAYOUT
- ▲ EASY TO ASSEMBLE

Description

The Acorn Powell WC cubicle system is manufactured from stainless steel and is ideal for locations subject to heavy usage and abuse. Cubicles can be supplied in a range of sizes and configurations to meet virtually any toilet layout requirement including those for disabled people and to provide baby changing facilities. A range of co-ordinated stainless steel washroom accessories is available to complement the WC cubicles, including toilet paper and tissue dispensers, napkin disposal bins and grab rails.

Construction

The WC cubicle doors and partitions are manufactured from 30 x 30 mm RHS grade 304 stainless steel formed into a framework and clad all around in satin polished 1.2 mm thick grade 304 stainless steel. The tops and bottoms of the doors and partitions are wrapped around and butted together, out of sight, to give a neat appearance and waterproof joint. Internal voids within the framework are filled with a sandwich of hardboard/polystyrene/hardboard for increased rigidity and sound deadening. Partitions can be provided with either lugs for surface mounting or wall bolts for concealed rear duct fixing.

The full height cubicle doors are hung on a continuous piano type hinge and are fitted with a heavy duty indicator lock assembly. Both components are manufactured from grade 304 stainless steel.

Intermediate partition and wall pilasters are formed from RHS grade 304 stainless steel.

A RSA header rail is provided, formed from grade 304 stainless steel, that is fixed to the top of each partition and, if applicable, the end wall for strength and stability.

The cubicle system is supplied in knock down form for easy site assembly by the installer.

Maintenance

Routine cleaning is necessary to maintain the appearance of stainless steel. Washing with soap or a mild detergent and warm water, applied with a sponge or bristle brush, followed by a clear water rinse is all that is required. Unless specifically formulated for use on stainless steel, bleaches, abrasive or chemical cleaners should not be used.



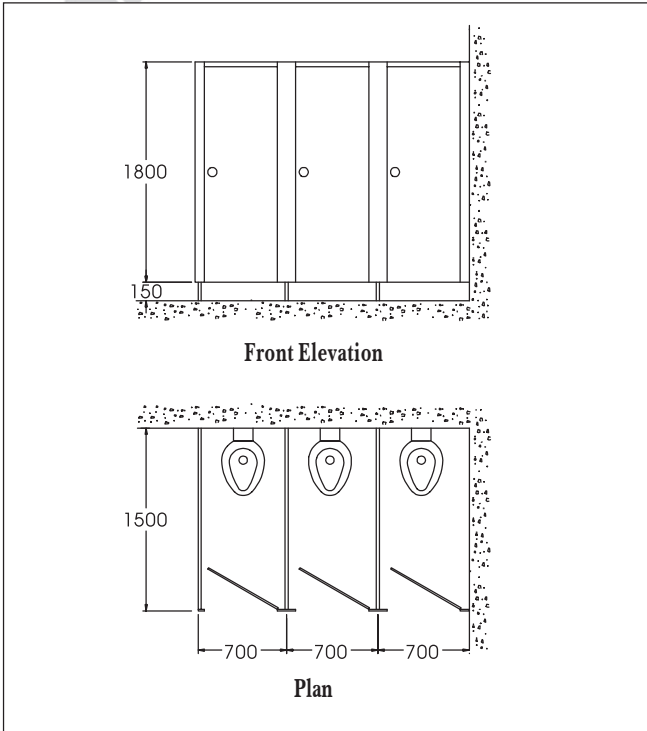

Dimensions

Overall Cubicle Height	1950 mm
Ground Clearance	150 mm
Overall Cubicle Width	700 mm min.
Overall Cubicle Depth (on plan)	1500 mm standard / up to 2000 mm special
Door Opening	600 mm min.
Pilaster Widths	50 mm and 100 mm

All WC cubicles are manufactured to suit specific site dimensions and layout of each installation.

Fittings

Each cubicle door is supplied factory fitted with a stainless steel indicator lock assembly and full length piano type hinge. The hinge can be fitted to either the right hand or left hand side of the door (as viewed facing the cubicle)

Installation

WC cubicles should be installed level and secured to the wall and floor using the fixings provided. Installation instructions are supplied with the product.

Ancillary Products

WC cubicles can be supplied with ancillary items such as:

- Privacy screens
- Duct panels
- Baby change tops
- Toilet roll and tissues dispensers
- Grab rail sets
- Disposal bins
- Hat and coat hooks

Product Code Selection for Order or Quotation

1. Base Product Code

- 161-stainless steel WC cubicle

Please provide sketch of WC cubicle configuration and layout, showing overall dimensions, position of walls, number of cubicles, handing of doors and stating whether surface or duct fixing is required.

For details of washroom accessories see catalogue section 6.

