

ASPHALT PAVEMENT

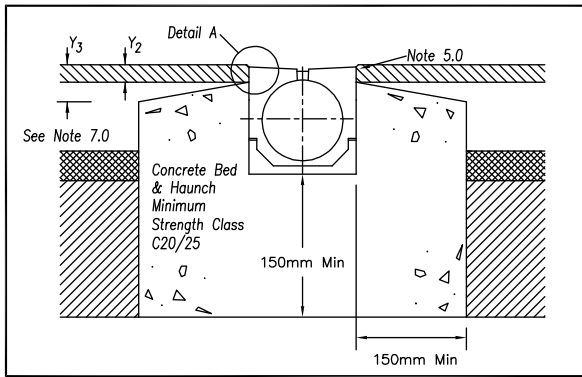

1.0 GROUND CONDITIONS: The customer should ensure that the minimum dimensions shown are suitable for the existing ground conditions. Engineering advice may be necessary.

2.0 BLOCK PAVEMENTS: THE CHANNEL MUST BE SUPPORTED LATERALLY and therefore blocks must be restrained from movement by bedding securely. e.g. by using an Epoxy or Polymer Modified Mortar for bed and perpendicular joints. (for example RONAFIX Mortar Mix C or similar: From Ronacrete Tel 01279 638700). Engineering advice may be required.

3.0 SURFACE CRACKS: Alternate crack control and movement joints transversely within bed and haunch may reduce unsightly surface cracking. Engineering advice may be required.

CONCRETE PAVEMENT

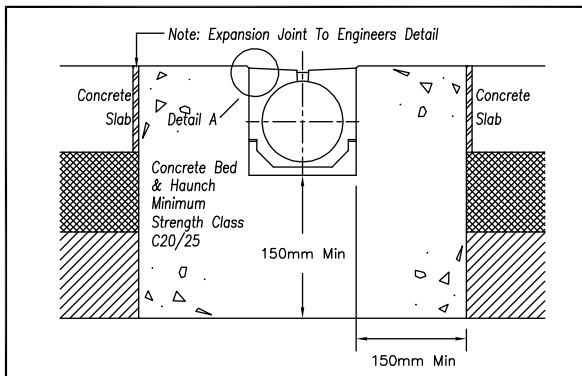

4.0 JOINT SEALANT: Where ACO Drain channel joints and fittings are to be sealed (where used in foul water applications or where impermeability is required, for example) contact a sealant specialist for guidance on the most appropriate sealing compound to use.

5.0 SURFACE PROTECTION: In asphalt pavements avoid contact between compaction equipment and channel. This may be achieved by ensuring that the finished surface level lies above the channel level (by at least 3mm). Stones should be removed prior to laying/rolling wearing course.

6.0 GENERAL INSTALLATION NOTES: See drawing E1-E01-003-3 for general notes on installation.

7.0 ASPHALT PAVEMENT: Top of concrete haunch
 Y2 = 35mm maximum
 Y3 = 60mm maximum

BLOCK PAVEMENT (OPTION 1 & 2)

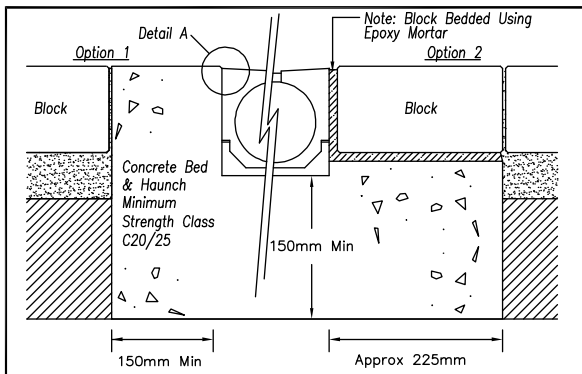

DETAIL A

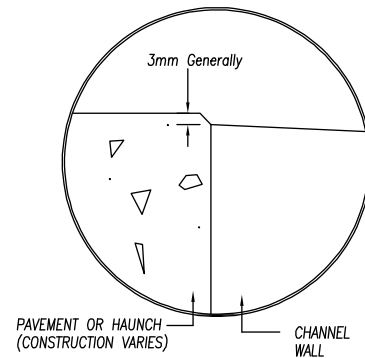

C	22.01.04	Concrete haunch; dimensions added to Asphalt Installation	RJAB
B	17.01.03	NEW CHANNEL SURROUNDS ADDED	RJAB
A	10.12.02	RE-DRAWN WITH NEW NUMBER	MJS
Issue	Date	Description	Name

Material:	n/a	Weight:	n/a	 ACO Business Park Hitchin Road, Shefford, Bedfordshire, SG17 5TE. Tel: 01462 816666 Web site: www.aco.co.uk
Tolerance:	n/a	Surface Finish:	n/a	

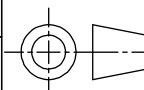
Date	Name	Scale:	Unit:	Projection: ISO-E	Information contained in this drawing is copyright property of ACO Drain. Any reproduction in part or whole without written permission of ACO Drain is prohibited
Drawn: 17-1-03	RJAB	1:10	mm		
Checked: 17-1-03	WSM		Project No. n/a		
Update:					

Title	ACO SLIMLINE CHANNEL INSTALLATION FOR LOAD CLASS C250	Drawing No.	E1 E01-021-3	Issue	C
-------	--	-------------	----------------	-------	---

Part No.	Replacement for: n/a
	Replaced by: n/a