

ACO Q-MAX 225 & 350 ACCESS CHAMBER WITH SLOTTED COVER AND FRAME

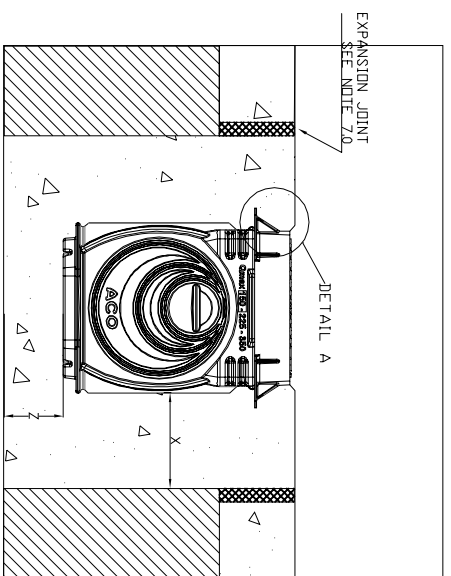

ACO QMAX 225 & 350 ACCESS, OUTLET/INLET AND SILT CHAMBER WITH SLOTTED COVER AND FRAME

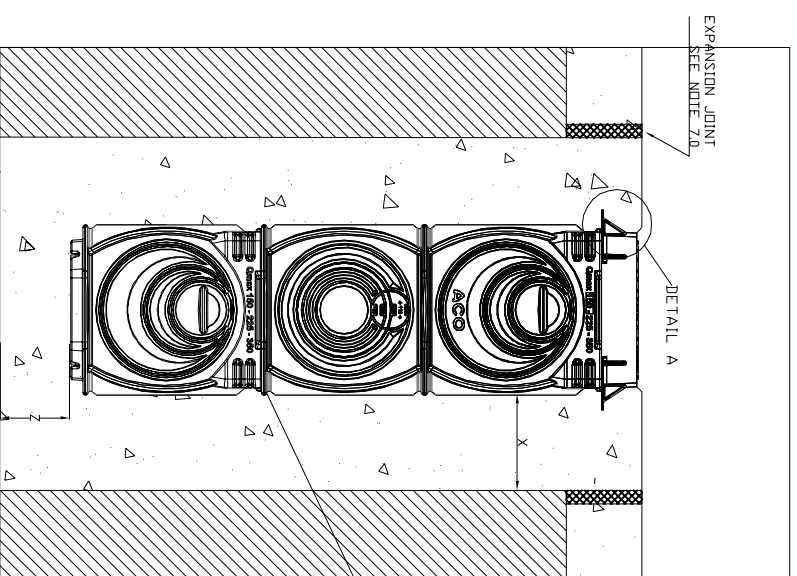

ACO QMAX 225 & 350 ACCESS CHAMBER WITH Q-SLOT RECESSED COVER

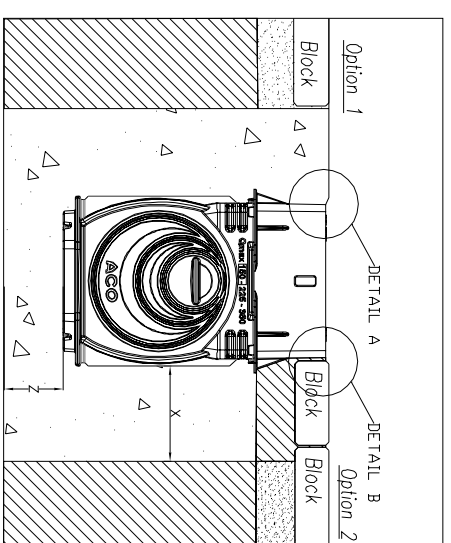

ACO QMAX 225 & 350 ACCESS, OUTLET/INLET & SILT CHAMBER WITH Q-SLOT RECESSED COVER AND FRAME

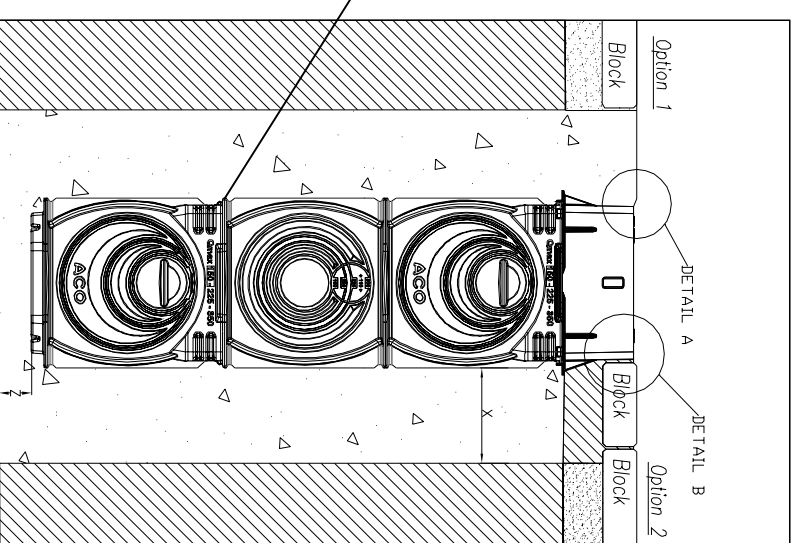

ACO QMAX 225 & 350 ACCESS, OUTLET/INLET CHAMBER C/W SLOTTED COVER AND FRAME

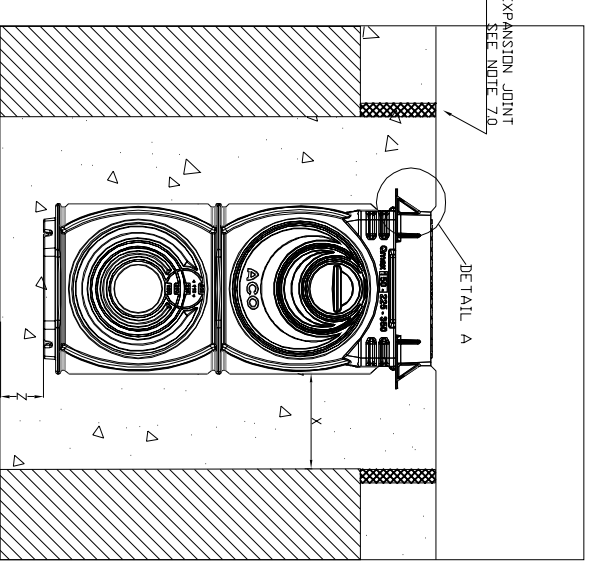

ACO Q-MAX 550, 700 & 900 DEEP ACCESS CHAMBER C/W SLOTTED OR SOLID COVER AND FRAME OVAL TO ROUND CONNECTION DETAIL. CAN CONNECT TO ALL ACO Q-MAX CHANNEL SIZES

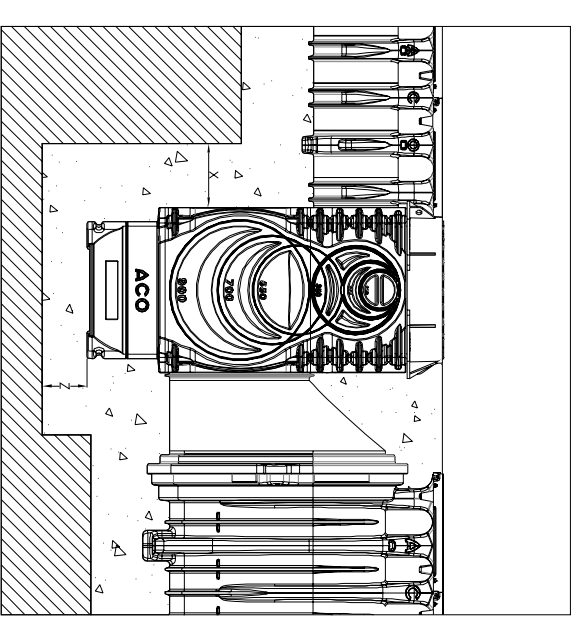

ACO QMAX 225 & 350 ACCESS, OUTLET/INLET CHAMBER C/W Q-SLOT RECESSED COVER & FRAME

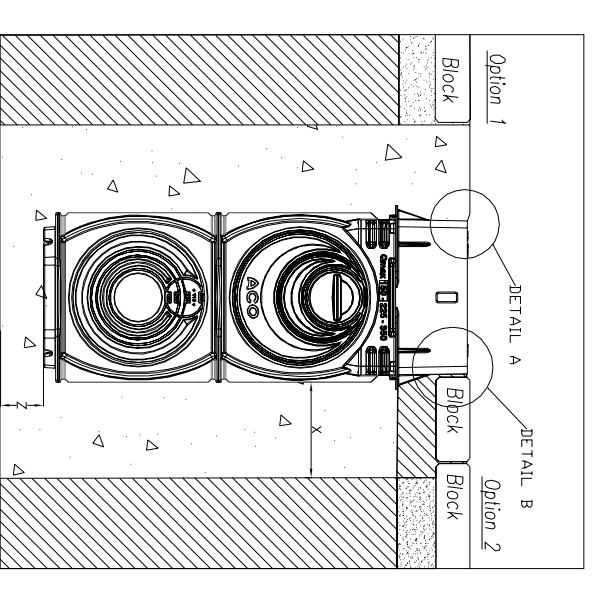

ACO QMAX 700 BRICKBUILT MANHOLE DETAIL - CONCRETE MANHOLE DETAIL SIMILAR (SEE NOTE 7.0)

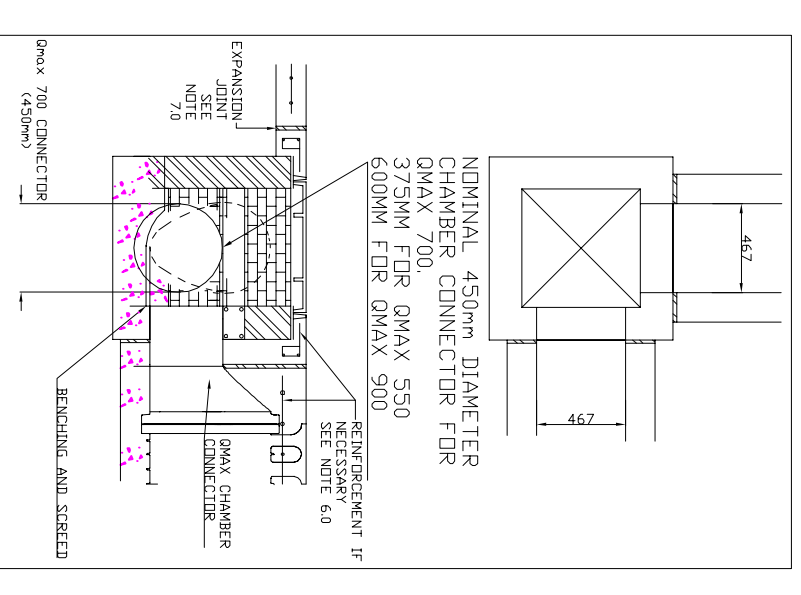

1.0 CHAMBER PREPARATION: Remove the appropriate ACO Qmax Access Chamber circular connection panel(s) with pad saw or similar. For the access, outlet/inlet and silt chamber; remove the base of the upper unit and the top of the lower unit.

2.0 EXCAVATION: Excavate including for the concrete bed and surround **SEE NOTE 5.0**. Allowance must be made for the access chamber, cover and frame.

3.0 CONCRETE BASE: Backfill the ACO Qmax Access Chamber with concrete to a depth of 300mm to fix the unit in place. Ensure the chamber does not float or move. For concrete class; see drawing E-1-E01-069-1 table 8.0

4.0 CHANNEL CONNECTION: Connect the channels; for the ACO Qmax 225 and 350 female channel connectors; the seal must be removed to connected to the ACO Qmax Access Chamber. Male channels can connect directly. For connection of ACO Qmax 550, 700 and 900 channels to ACO Qmax Access Chamber an Access Chamber Connector must be used. The Qmax Access Chamber Connector must be cut and the pipe connection detail removed, to enable connection to the ACO Qmax Access Chamber.

5.0 CONCRETE SURROUND: Install and backfill access chamber and channels with concrete as per ACO installation detail. Remove ACO Qmax Access Chamber top panel prior to installation of frame and cover. The minimum class of concrete is given in table 8.0 on drawing E-1-E01-069-1; depending on channel size and load class required with the chamber, subject to the client engineer's specification.

6.0 CHAMBER DESIGN: The customer should ensure that the minimum dimensions shown are suitable for the existing ground conditions. The structural design/reinforcement of the concrete surround is to be determined by the client. Engineering advice may be necessary. The reinforcement required in the construction varies with the installation group (load class).

7.0 JOINTS: The detailing of joints is to be determined by the engineer in conjunction with the detailing of the pavement. A longitudinal expansion joint is typically formed down each side of the chamber (as indicated). Where the pavement is asphalt or block paving (with no concrete slab), then expansion joints may not be necessary. Engineering advice should be sought.

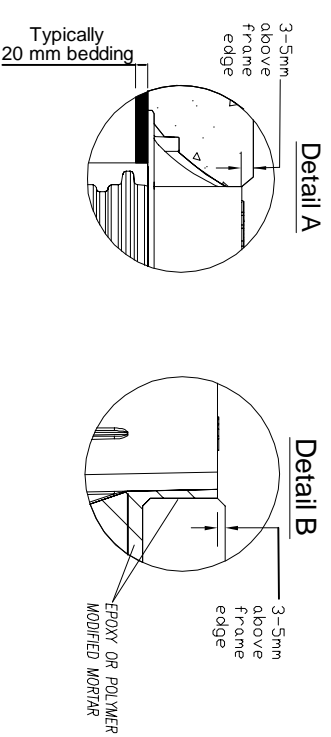

A	12.09.2012	ACO Qmax Access Chamber Installation Detail		KS
Issue	Date			
Scale:	N/A @ A3			
Drawn	29.07.11	Name	Checked by	Drawing No.
Updated	16.11.11	RS	JC	E1-E01-070-1
Title:	ACO Qmax ACCESS CHAMBER INSTALLATION DETAIL			
		Projection: ISO-E		
		Unit: mm		
		ACO Business Park Hitchin Road, Shefford , Bedfordshire, SG17 5TE Tel: 01462 816666 Web: www.aco.co.uk		
		<small>Information contained in this document is the property of ACO Technologies. Any reproduction in part or whole without written permission of ACO Technologies is prohibited.</small>		
Issue	A			