

Uniclass L7315	EPIC J3413
Cl/SfB (52.5)	

## ACO Water Management: Civils + Infrastructure

### ACO Derailment channel

- ✓ Traps tram wheel in the event of derailment
- ✓ Gratings designed to collapse if struck by a wheel
- ✓ Provides effective surface water drainage to the 'Swept Path' area of the track
- ✓ Offers stray current protection
- ✓ Protects against corrosion to buried underground services
- ✓ Manufactured from sustainable, thermally stable material
- ✓ Strong and robust channel design

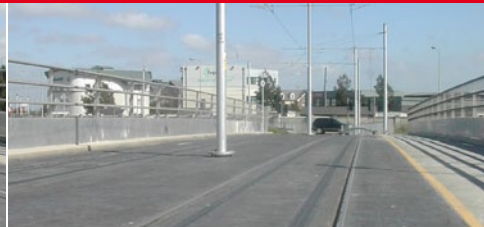

### *ACO Derailment channel*

## High strength derailment channel drainage system

The ACO Derailment channel traps and contains the wheel of a stray tram in the event of derailment. The system is installed parallel with the tram track and is fitted with frangible gratings which will collapse if struck by a wheel.

In addition, the ACO Derailment system provides effective surface water drainage for the 'Swept Path' area of the track.

The system is manufactured from Vienite®, ACO's high strength sustainable material that meets environmental and sustainability targets for construction products. Vienite® provides protection against stray currents and corrosion to buried underground services as the material does not conduct electricity.

Each ACO Derailment channel unit is fitted with composite edge rails and Heelguard™ composite gratings which are certified to Load Class C 250 BS EN 1433:2002.

An outlet channel assembly is also available with a preformed Ø110mm pipe union for connection to underground drainage.

### Typical applications

- ▶ Tram Schemes and Depots
- ▶ Light rail development



# ACO Derailment Channel

## System overview

### Features

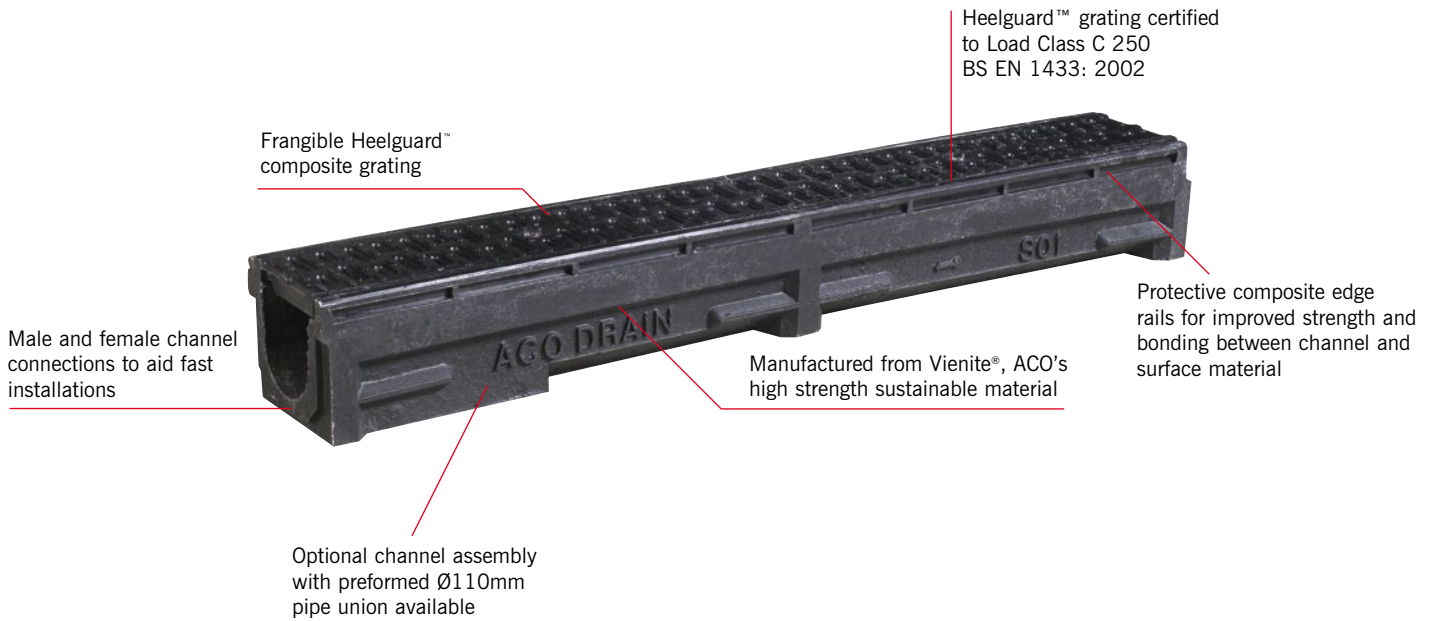

### ACO Derailment Channel

Product code	Description	Length mm	Width Overall mm	Depth Overall mm	Invert mm	Weight (kg)
T0059	ACO Derailment Channel	1000	155	138	112	21.2
T0060	ACO Derailment Outlet Channel	1000	155	138	112	20.6

ACO Derailment Channel

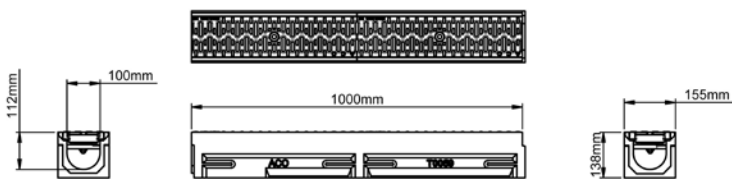

ACO Derailment Outlet Channel

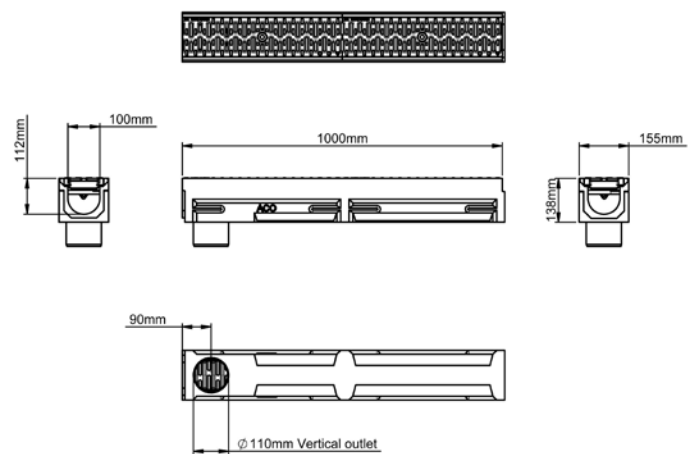

#### ACO Technologies plc

ACO Business Park, Hitchin Road, Shefford, Bedfordshire SG17 5TE

Tel: 01462 816666 Fax: 01462 815895

e-mail: [technologies@aco.co.uk](mailto:technologies@aco.co.uk) website: [www.aco.co.uk](http://www.aco.co.uk)