



Product Catalogue | April 2015

Emergi-Lite Emergency lighting systems

 **EMERGI-LITE®**

Power and productivity
for a better world™ 

Legend



BSI Kitemark approved



ENEC certified The products have been tested and certified by an independent European certification agency such as KEMA



Luminaire complies with CE



Insulation class II. This luminaire must not be earthed.



Luminaire may be attached to a flammable surface.



Product comes with a self-tester



The light source of the product is a fluorescent tube



Product comes with an LED light source



Surface mounted luminaire



Recess mounted luminaire



Indicates protection class (IP value)



Self-contained: in case of power failure, the luminaire is battery powered; the luminaire mains voltage is 230V - 50Hz



Maintained / non-maintained luminaire



Non-maintained luminaire



Indicates the viewing distance of the (illuminated) pictogram in metres



3 hours autonomy (battery-powered light operating time)



Fitted with an infrared module



This product is also available with Naveo addressable ,testing and remote management facility.



Rear plate



Protection kit



Side wall bracket



Ceiling bracket



Suspension kit



Recess kit



24 hours recharge period

Emergi-Lite

Emergency lighting systems

Introduction & Technical reference for design	1
Naveo & Central power supplies	2
Guideway	3
Serenga	4
Endurance	5
Horizon	6
Corniche	7
Previx	8
Silverlite	9
Navigator	10
Weatherforce	11
Wayfer	12
Day-lite	13
Cordona	14
Silver-scape	15
Aqualux	16
Portable Work-Lite	17
Range-Lite	18



Hq assessed to bs en iso9001: 2000 for the management of emergency lighting and fire detection equipment and the modification of mains luminaires for emergency lighting applications. Cert no: FM09470



Introduction

Emergi-Lite emergency lighting systems

1

The Emergi-Lite concept is clear and simple. Emergi-Lite offers you reliable total solutions for safe evacuation. The way in which we do this is what makes the difference. Emergi-Lite offers advantages to everybody involved in the construction process. That way, you know that Emergi-Lite is always the right choice, for both you and your customers.

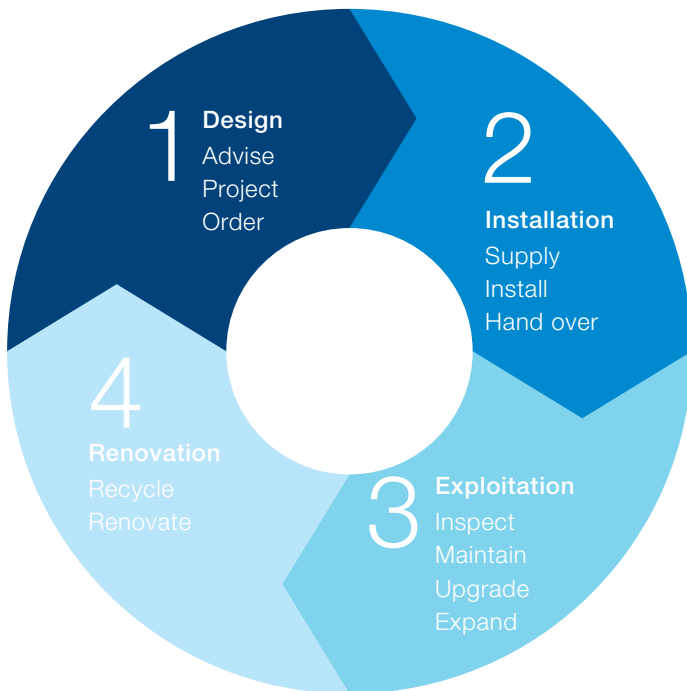

Advice and information during the design phase

Each phase requires different input from us. In the design phase, it is important for you to have all the information. If desired, we can provide you with that in the form of specific project advice, based on the most recent regulations, standards and safety requirements. Emergi-Lite always offers you the necessary information in the most compact form, so that you quickly have an overview of all the available information. For example, you can use this brochure to put your product together in three simple steps. It is up to you whether to go for digital information via deep links on your wholesale website or whether to use a hard copy of the Quick Guide. Emergi-Lite offers you both options.

Speed and materials during the installation phase

Speed and timing are essential during the installation phase, because the easy-to-install materials must be at the construction site at the right time. That is why luminaires such as Serenga, Horizon and Aqualux are always in stock. If you perform the installation yourself, clear assembly instructions, packaging instructions and a modular system give you a head start.

For example, with Emergi-Lite's quick-assembly modules, you do not have to climb a stepladder so often. Emergi-Lite offers you practical solutions to give you an immediate advantage, which only makes everything so much easier for you.

Support during the exploitation phase

During the exploitation phase, we can document your emergency lighting installation and make sure it is up to date. That way, you guarantee optimal safety at minimum exploitation costs, thanks to low energy consumption and easy-to-replace parts and, if necessary, the people who are working, shopping, relaxing or sleeping in the building can quickly and safely find their way out.

Altering and separating during the renovation phase

The new generation of Emergi-Lite products is ready for the renovation phase. Emergi-Lite goes further than the normal use of durable, environmentally-friendly, recyclable materials. The products are easy to disassemble and easy to dispose of separately in the legally required return and recycling flows. It is also easy to alter the new generation of luminaires using the individual modules.



Technical reference for design

Legislation & requirements

The requirement for emergency lighting originates from the Fire Precautions Act 1971 and was further enforced by the Fire Precautions (Workplace) Regulations 1997 (Amended 1999).

The Regulatory Reform (Fire Safety) Order, FSO came into force in October 2006 and now replaces all previous fire safety legislation.

The key considerations from the Fire Safety Order are:

- The FSO creates one simple fire safety legislative control for all workplaces/non-domestic premises
- Control is fire risk assessment based, with the responsibility for fire safety resting with the 'responsible person' for the premises
- All persons inside the building/in the vicinity who might be affected by a fire must be protected
- Employees will be required to act upon the fire risk assessment, make remedial arrangements accordingly and maintain the fire precautions
- Failure to comply with the rules would be a breach of law, with the consequence of enforcement or prohibition notices being served

The fire safety risk assessment is a legal requirement, and where a site has 5 or more employees the risk assessment must be documented.

Fire certificates under the Fire Precautions Act 1971 are now no longer valid. Guidance documents on the new Fire Safety legislation have been published and the appropriate ones must be consulted as part of the overall fire risk assessment.

Other important legislation and regulations, such as The Buildings Regulations and The Health and Safety "Safety Signs and Signals" Regulations 1996, also have a requirement for emergency lighting and must be considered as part of the design and specification. A number of standards have been devised to provide guidance on application of emergency lighting in line with legislative requirements, and to determine the quality of product to be specified.

The major standards to be considered when designing a high-level emergency lighting system are:

- **BS 5266-1, -7 and -8**
This standard sets the guidelines for installation of emergency lighting, as to the location and frequency of emergency luminaires and exit signs, and the minimum lighting levels required
- **BS EN 60598.2.22**
This is the product standard which establishes the performance requirements of emergency lighting luminaires and internally illuminated exit signs
- **IEC 62034**
This standard defines the requirement for automated testing systems for emergency lighting
- **ICEL1001, ICEL1004 & ICEL1009**
Guides and registration schemes provided by the Industry Committee for Emergency Lighting which define enhanced performance requirements for the differing types of emergency lighting, backed by independent testing

Exit signs

Designated legend formats

European pictogram format signs are acceptable, as are ISO 7010 format signs, although there should not be a mixture of both within an installation.



Text only signs are no longer acceptable and should have been withdrawn.



Maximum viewing distances

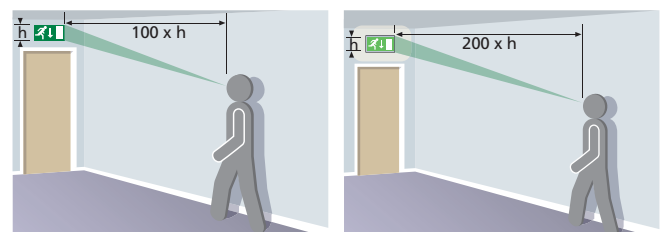

Figure A. Exit sign boards have a maximum viewing distance defined as 100 x the height of the sign (h), in metres

Figure B. For illuminated exit signs, the maximum viewing distance is defined as 200 x the height of the sign (h), in metres

Technical reference for design

Legislation & requirements

1

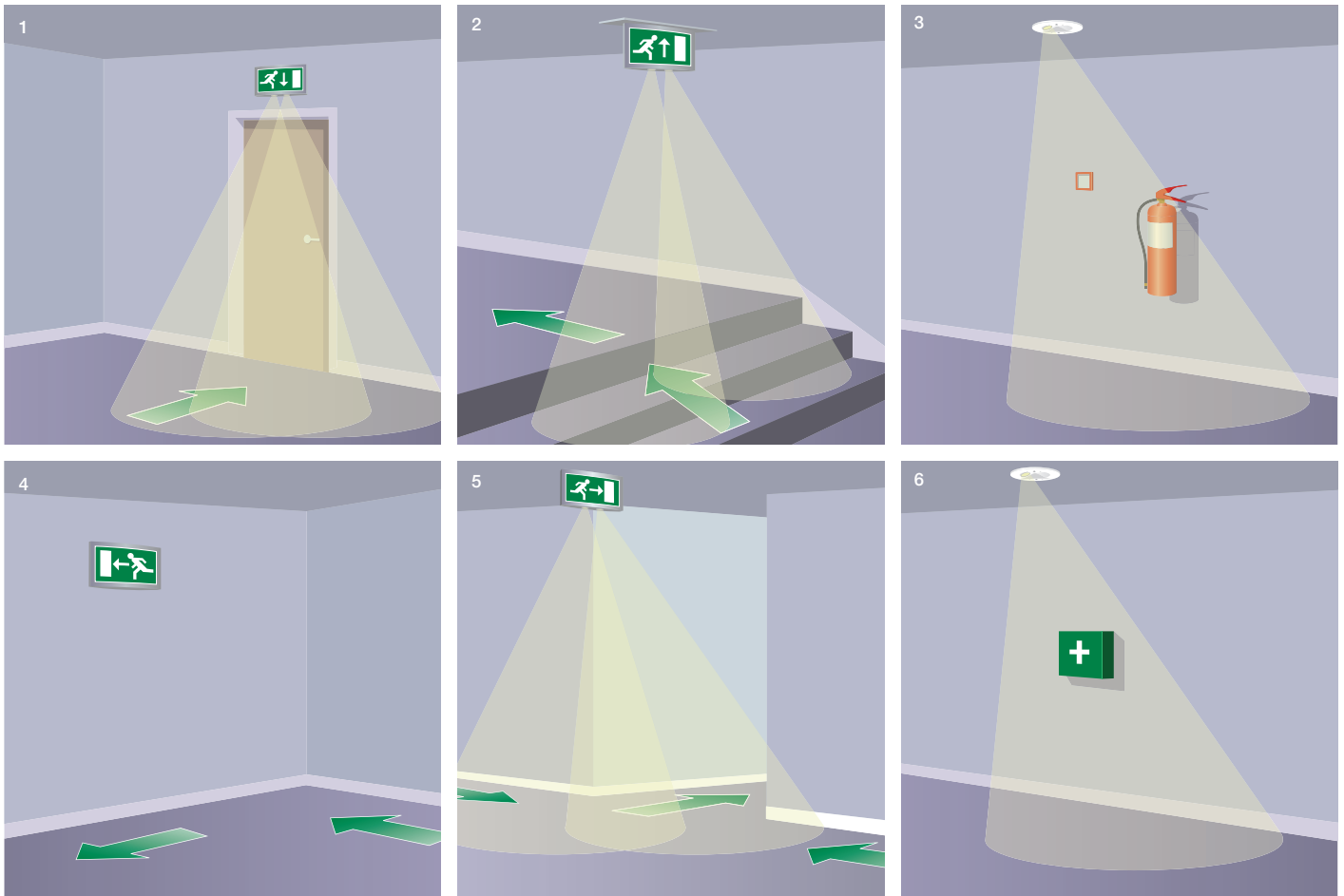

1 Near an exit door | 2 Near changes in direction | 3 Near stairs and changes of level | 4 Near the intersection of a corridor
5 Near each piece of fire-fighting equipment or manual call point | 6 Near each First Aid point

General requirements for emergency lighting (BS 5266-1, -7 and -8)

If emergency lighting is required it should:

- Indicate the escape routes clearly with exit signs so there is no doubt which is the way out
- Ensure fire safety equipment such as fire alarm call-points, fire extinguishers etc can be located
- Illuminate escape routes, and open areas used in escape routes so that obstacles can be avoided
- Provide illumination for high risk task areas to allow the processes to be shut down safely

Any point on an escape route or leading to it must have an exit sign so that direction of travel is never in doubt. Internally illuminated exit signs offer the most effective method of achieving the requirement, and have a viewing distance twice that of exit signboards- see right.

Note: where exitsignboards are installed, these must now have 5 lux illuminance on the sign to meet the requirements on BS 5266 / EN 1838 - for practical purposes unachievable through use of converted mains luminaires.

Points of emphasis

Mandatory points of emphasis have been established where directional signage or specific illumination is required.

These are:

- Near an exit door
- Near changes of direction
- Near stairs and changes of level
- Near the intersection of a corridor
- Near each piece of fire-fighting equipment or manual call point
- Near each First Aid point

Technical reference for design

Legislation & requirements

In addition to these points of emphasis, the following need to be considered when planning emergency lighting.

Escape routes

A defined escape route of 2 m width must be illuminated to a minimum of 1 lux along the centre line (see right).

Open areas (anti panic)

Open areas must be illuminated to 0.5 lux minimum in the core area (see below right). This also applies to areas with undefined escape routes, in halls or areas greater than 60 m².

High risk task areas

This refers to areas normally associated with moving machinery, dangerous materials or processes, and other areas of high risk where hazards may continue after mains lighting failure.

Illuminance levels should be maintained at 10% (or over) of the normal lighting level or 15 lux, provided within 0.5 seconds, to allow for safe egress and/or termination of processes. For high risk task areas, the lux requirement is calculated at the plane of the task rather than floor level.

Additional areas

Additional areas not part of the escape route still require illumination as people may be located there and/or measures may be required to ensure the safety of persons or processes. These areas include kitchens, first aid/operating rooms, lifts, refuge areas, escalators and moving walkways, toilets larger than 8 m² (or smaller without borrowed light), disabled toilets, small lobbies and pedestrian routes within covered car parks.

System integrity

All compartments should include two or more emergency luminaires to counter the risk of emergency luminaire failure.

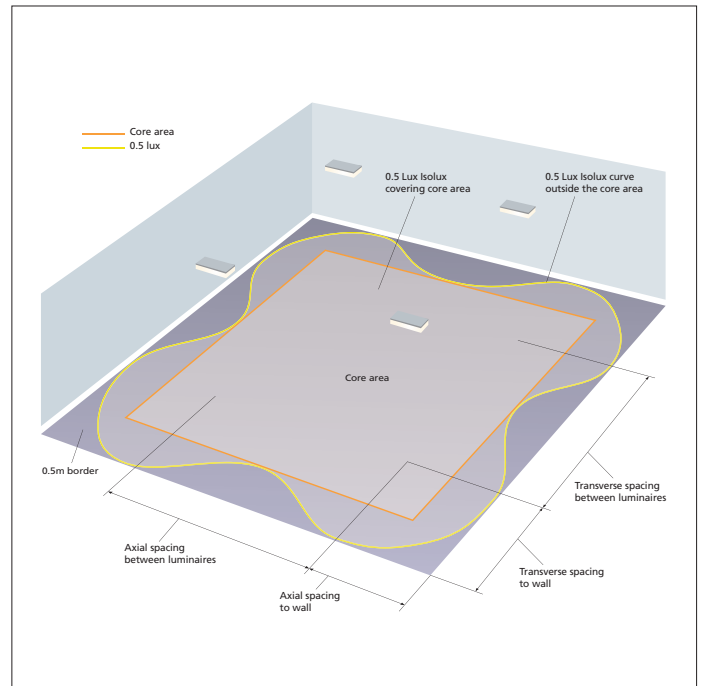

Figure C. Core areas

Luminaire mounting height

Emergency luminaires should be mounted at least 2 m above the floor. There is no upper limit but luminaires should be fitted below smoke level if there is a significant risk of floor illumination being affected.

Stand-by lighting

If stand-by lighting is used as emergency lighting it should conform to all the requirements of emergency lighting.

Figure D. Escape routes with transverse and axial luminaires

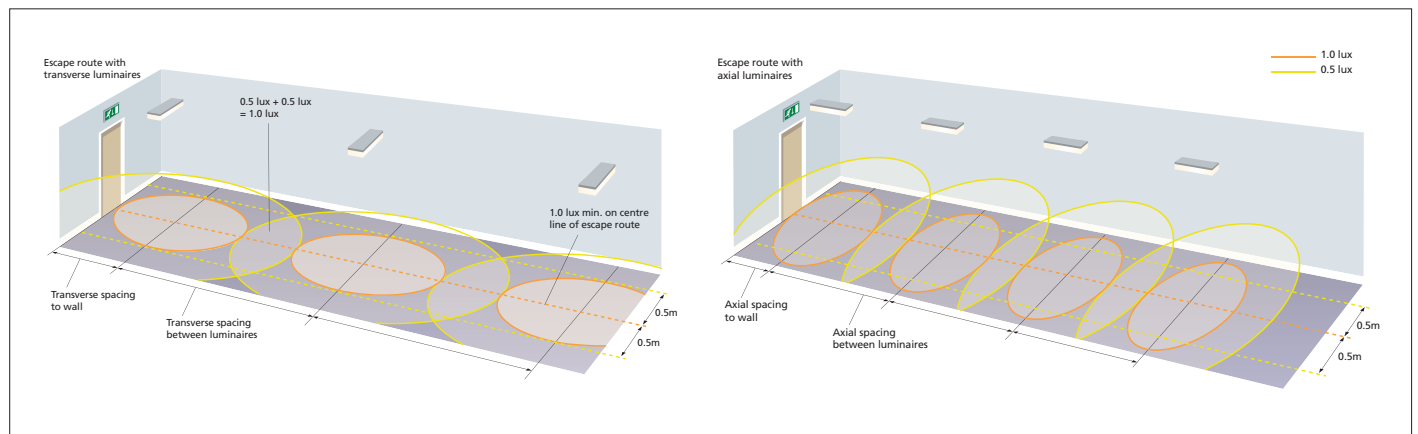

Technical reference for design

Legislation & requirements

1 Specific location requirements

BS 5266 stipulates light levels, response and duration times for specific locations within premises, and for specific activities, including:

- Kitchens
- First Aid rooms
- Examination and treatment rooms
- Refuge areas for the mobility impaired
- Plant rooms, switch rooms and emergency winding facilities for lifts
- Reception areas
- Crash bars or security devices at exit doors
- Inspection of the condition of fire control and indicating equipment

A table showing the illuminance recommendation for these specific locations and requirements can be found in BS 5266-1.

Emergency lighting systems

There is a varied range of emergency lighting available to suit different budgets, decors, building requirements, colours and specifications. The types and categories available for specification are:

Types of emergency lighting

- **Self-contained**
Each luminaire contains a battery and electronic circuitry to charge batteries and operate the lamp
- **Slave**
Luminaires are powered from a central system
- **Conversions**
Almost any mains fluorescent luminaire can be converted for emergency use. Emergi-Lite is registered to ICEL 1004 to undertake emergency lighting conversions at our head office facility in Leeds, UK

Categories of emergency lighting

- **Non-maintained (NM)**
Luminaires operate when the mains fail.
- **Maintained (M)**
Luminaires operate when the mains fail, but can also be operated if required using a switch when the mains supply is healthy
- **Combined Non-maintained (CNM)**
The luminaire contains more than one lamp, one of which is mains operated, the other is for emergency use only. When the mains is healthy one or more lamps operate, but should the mains fail the emergency lamp operates.
- **Combined Maintained**
Similar to combined non-maintained, but when the mains supply is healthy both lamps operate, whereas on mains failure only one lamp operates.

CE marking alone on an emergency lamp does not necessarily imply that the product will work in an emergency situation. All emergency lighting must be designed and manufactured to meet the requirements of BS EN 60598.2.22, the established product standard.

Emergency lighting products may be independently certified and approved as a means of proving quality in the product, thereby giving an enhanced level of assurance to the installer, and greater confidence and less risk in the work he performs. Emergency lighting independently tested and carrying the approval of a recognised national standards body, such as the BSI Kitemark or European ENEC mark, serves this purpose.

Selecting products from a reputable manufacturer also serves to assure that products and services supplied will perform satisfactorily. National certification bodies such as BAFA - British Approvals for Fire Equipment - provide, through schemes such as SP203-4, third party certification and recognition that emergency lighting manufacturers have competency in undertaking design, installation, commissioning and maintenance of such systems. Emergi-Lite is a core member of the BAFA scheme.

Testing and maintenance of emergency lighting

Fire legislation requires the safety systems within a building to be tested and maintained to ensure correct working order.

The major standards for emergency lighting establish the testing requirement, and that testing and maintenance should be done by a "competent person" (trained, with appropriate skills and experience).

Automated testing solutions are available to assist with the testing requirement, such as the Self-Test, IR2 infra-red and Naveo addressable testing solutions available from Emergi-Lite (see pages 72 - 78 of this catalogue for more details on these solutions).

For automated testing solutions, IEC 62034 provides specific guidance for luminaire testing, including:

- Testing should be undertaken during periods of low risk
- Tests should be performed at the appropriate times for the correct duration
- Testing should prove the emergency circuit operates correctly, and that the battery powers the luminaire for the duration of the test
- Results of the test should be reliably indicated

Within the IEC 62034 Standard, test systems for both self-contained and centrally powered emergency lighting systems are covered.

Technical reference for design

Checklist for emergency lighting system design

Checklist for emergency lighting system design

Point	Establish	Action
1	Establish position of fire equipment, position of hazards such as steps, changes of direction, stairs, first aid points etc.	Provide an emergency luminaire near (within 2 m horizontally) of each of these points of emphasis.
2	Establish designated exit doors, points on escape routes or where a sign is required to make the exit obvious.	Provide exit signs with arrows if necessary, observing the maximum viewing distances of the exit sign type.
3	Establish the need for external escape lighting.	Provide emergency luminaires so that people can proceed outside to a place of safety.
4	Establish the escape routes and establish mounting heights of	Position luminaires along parts of the escape route not already illuminated near the above points to provide 1 lux minimum along the centre line and 0.5 lux minimum in the 1 m central band. Use published data in the form of spacing tables for the luminaires to determine the positions taking into account the mounting height.
5	Establish the open areas used as escape routes and other open areas larger than 60 m ² and establish mounting heights of luminaires above the floor.	Provide 0.5 lux minimum in the core area. Use published data (as above) to determine the positions.
6	Establish the position of lifts, escalators, toilets, control/plant rooms, pedestrian walkways in covered car parks.	Provide emergency luminaires in all of these areas.
7	Establish the location of any first aid point or fire equipment not on an escape route or open area.	Provide 5 lux emergency illuminance on the floor in the vicinity of the point. This also applies for a first aid room.
8	Establish the toilet areas.	Provide emergency lighting for toilets larger than 8 m ² , as if they were open areas. For toilets smaller than 8 m ² , unless illuminated by borrowed emergency light from another area, provide at least one emergency luminaire. Provide emergency lighting to all disabled toilets.
9	Establish any small lobbies with no borrowed light.	Provide emergency lighting.
10	Establish any central power supply (if used) is in an area of low risk away from other switchgear or plant.	Position the central power supply in its own room in fire-proof construction.
If the building use is known:		
11	Establish any need for stand-by lighting.	Provide generators as required. If the response time is longer than 5 seconds, then transitional, alternative or additional emergency lighting must be provided.
12	Establish any special needs for the occupants such as impaired mobility or impaired sight.	Provide additional emergency lighting to reduce the risk to those people to help them evacuate the premises. This applies to designated refuge areas (which may require the provision of emergency voice communication).
13	Establish the location of any high risk task areas and the normal lighting illuminance (lux) in these areas.	Provide 10% of the normal illuminance (lux) or 15 lux minimum.
14	Establish if there are any dust or dirt problems.	Allow a service factor as appropriate. 0.8 is allowed for normal areas, but for dusty environments 0.5 may be required, or alternatively instigate a regular cleaning procedure.
15	Establish any local regulations.	Provide emergency lighting to comply with the regulations.
13	Establish if there is any dimmable lighting and shopping malls.	Provide maintained emergency lighting.
17	Establish whether people would be "unfamiliar" with the escape routes.	Provide maintained exit signs.
18	Establish the use of the premises:	Recommended Minimum Duration:
	– entertainment (including temporary such as licensed evening dance at a school)	3 hr
	– sleeping risk	3 hr
	– residential special care	3 hr
	– non-residential care	1 hr
	– public access non-residential	1 hr
	– industrial	1 hr
	– multi-storey dwelling over 10 storeys	3 hr
	Note : because the duration times are varied, it is customary in the UK to use 3 h.	

Note: for points 5 and 6 the luminaires positioned near points of emphasis can be moved slightly within the 2 m horizontal tolerance to fit in with the spacing or array of emergency luminaires in the escape route or open area. This checklist is for guidance purposes only and does not form an exhaustive list of all requirements to standards and legislation, which should be reviewed when undertaking emergency lighting system design. '60Hz' option available on request, please contact Emergi-lite

Naveo

Inspection and maintenance software

2

Addressable emergency lighting testing with cloudbased remote management and monitoring. Naveo delivers the ultimate solution to managing emergency lighting, by allowing you to control the entire emergency lighting installation, inspection and maintenance process from any point, with system information and reports available at any time.

Naveo combines pre-programmable emergency lighting testing with cloud-based electronic record keeping and system management, to dramatically reduce the expense and burden that manual testing, maintenance and fault checking brings.

- Comprehensive range of emergency lighting testing solutions for all sizes of project
- Removing the disruption that manual luminaire testing brings to the busy, modern business environment
- All testing solutions compliant to IEC 62034

Building on the success of Emergi-Lite's Centrel addressable testing system, Naveo places control firmly at your fingertips, with immediate access available anywhere via smartphone, tablet, laptop or PC. This innovative approach breaks new ground in enabling end users to manage multi-site emergency lighting systems wirelessly, with system performance and maintenance records held 'in the cloud'.

Furthermore, Naveo is responsive and promotes increased building safety, by supplying maintenance and fault updates via email or text to repair teams, with parts listings by PDF, enabling forward planning of maintenance and spares ordering with ease.

The benefits of Naveo are significant:

- Naveo offers a fully customisable solution for emergency lighting testing, irrespective of the size or location of the site, or whether multiple sites are being managed
- Naveo makes your time and resources more productive by saving valuable time spent every year on manual collection and recording of emergency lighting data
- Internet-based Naveo control software holds all system testing and maintenance data securely within an external server, for access anywhere, at any time, via smart-phone, tablet or PC
- Naveo software updates are automatically applied, with new luminaire parts and product information automatically updated in the background

- All Naveo emergency lighting luminaires are individually addressed, making fault assessment and location a simple task
- Automated pre-programmable test schedules provide the status of the lamp, battery and PCB, and upload directly to remote server
- Most of the inspection work can be completed onscreen by simply ticking off emergency luminaire status as 'OK' or 'Defective' on your mobile device or PC
- Preventative alerts and fault updates are provided by email or SMS, with spares requirements by PDF, for optimal forward planning of maintenance
- At the push of a button you have an overview of potential and current maintenance issues, allowing you to structure the data you require
- After an inspection, the Naveo software can generate an EN 50172-compliant PDF log for on-site record keeping and inspection by the relevant authorities, as appropriate
- Naveo system backwards compatible with CT luminaires



Naveo

24/7 control at your fingertips

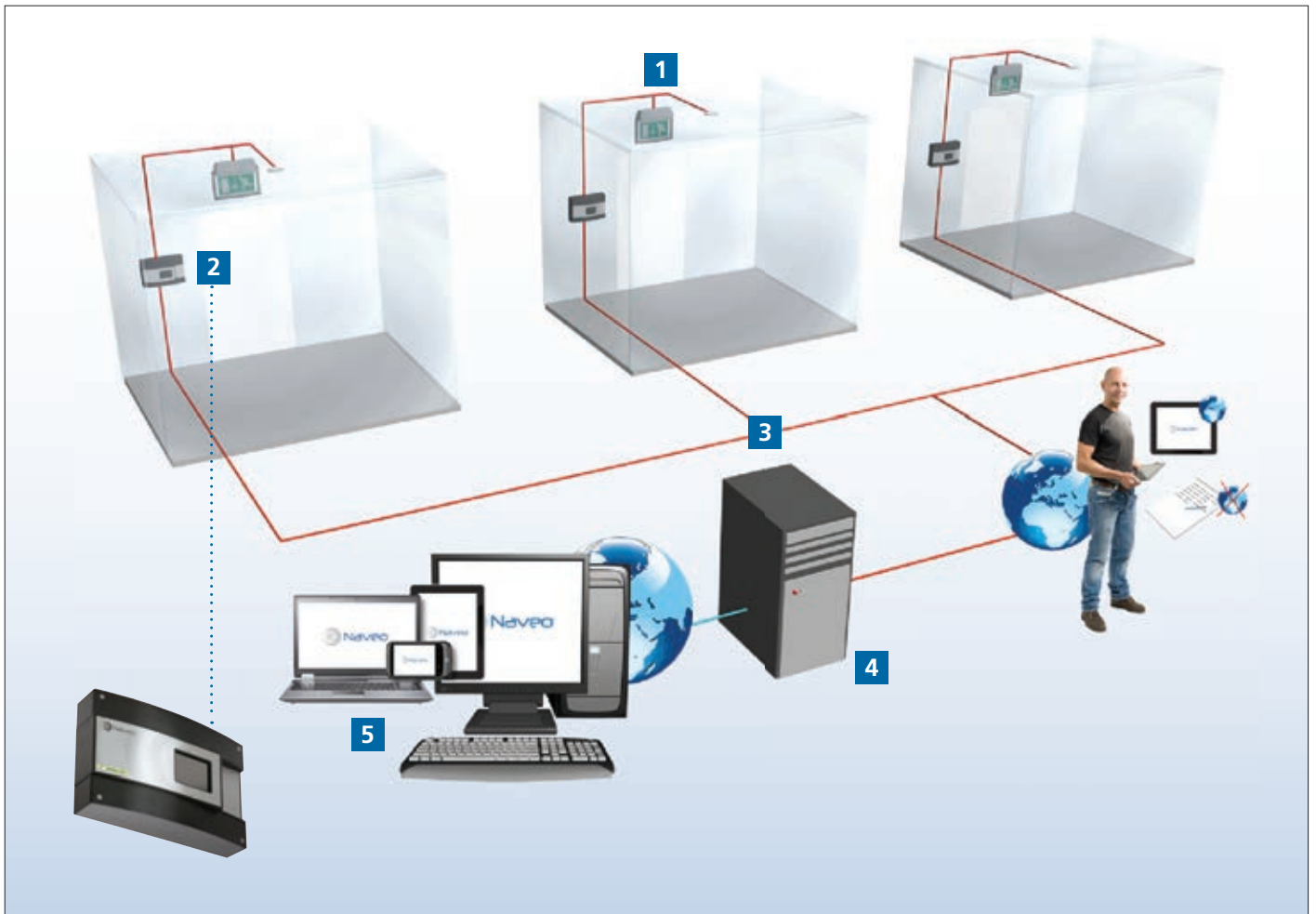

- 1 Bus communication cable
- 2 Data Collection Panel (DCP)
- 3 Internet connection
- 4 Naveo external server with all DCP information
- 5 PC, smartphone or tablet

How does Naveo operate?

Each emergency lighting unit includes an individually addressed testing module which conducts functional and duration tests and communicates results to the DCP 2. Each DCP is designed to collate test data from up to 750 emergency lighting units.

The DCP transfers all data to the Naveo secure external server 4 via an encrypted internet connection 3.

All test results are collated and processed at the external server, with maintenance requirements and faults logged and transmitted to maintenance teams for action, either to PC, laptop, smartphone or tablet 5.

Status information and test reports can be accessed securely from anywhere and any device with internet connection, making maintenance planning simple.

Naveo

Customisable solutions

Naveo offers a fully customisable solution to managing emergency lighting:

The Naveo solution offers a convenient range of pricing packages dependent on the size and scope of the installation,

enabling customers to tailor to their specific needs. Additional upgrades can be added at any time to include new emergency luminaires into the system, making the solution highly scalable. For further details, please contact Emergi-Lite.

2



When do you need to test?

Fire Safety Regulations require emergency lighting to be tested in accordance with BS 5266-8 (EN 50172).

Simplified Testing Regime

- Daily check central power supply indicators for healthy operation
- Monthly functional check
- Yearly duration check
- Always keep documented records
- Automatic test devices should meet IEC 62034

What needs to be checked & tested?

- Mains present and healthy
- Battery present
- Battery charging
- Inverter circuit in emergency operation
- Lamp functions and in circuit
- Duration

Effective testing with Naveo

Naveo's comprehensive, technologically advanced approach ensures testing to meet the requirements of BS 5266-8 (EN 50172):

- Naveo tests can be run either manually or automatically
- Unattended tests can be performed using the schedule program
- All automatic test schedules can be easily programmed for the type of test required and for the time the test is to be performed
- All results of tests are stored at the remote server for recall at a later date

- Each luminaire is programmed with an address which is used for interrogation and fault diagnosis

Supporting Naveo installations

Naveo is fully supported through our project sales and technical teams, including:

- Design of the emergency lighting system with Naveo compatible emergency luminaires
- Practical advice on installation matters, such as power and data cable structure, system set-up etc
- Full commissioning of the system, pre-operation, from our highly experienced field service team
- Maintenance contracts, available as required to support the installation, for added peace of mind
- Project after-sales support, with project files retained by our service department so that preparation of additional luminaires as required is a straightforward task

Technical literature & advice

Please contact a member of our sales team for full details and advice on Naveo, including:

- Technical design guide, providing in-depth technical information on the system
- System demonstrations, arranged at your own premises or at our head office for an informed assessment of the system and software capabilities

Additionally, a separate brochure explaining the Naveo solution in full is available on request.

Central power supplies

EMEX Range

Our Central Power Supply Systems division offers a choice of reliable and high quality products which are designed to meet the relevant standards and specifications for both AC/AC and AC/DC applications. The 'EMEX Power' and 'EMEX TS' static inverters, 'EMEX 110' AC/DC and 'Compact Power' product ranges are manufactured in our Leeds facility, supported by an experienced engineering, sales, and commissioning team.

2



EMEX – AC/AC Static inverter range: 220-230V 50/60Hz, 400V. 3ph 50/60Hz

Static inverters in this range are true passive stand-by emergency lighting units, designed and built to exceed current emergency lighting standards and technical requirements, something with which most UPS based central power products do not comply. EMEX Power, EMEX TS static inverters and EMEX Mini power systems offer a low maintenance and extremely reliable central power supply solution with low running costs and a high degree of functionality to serve individual customer needs.

- Modular design, which makes maintenance or repair a simple task
- Manufactured in the UK
- Normal mains luminaires with electronic starters/high frequency ballasts may be driven by the system (glow wire starters cannot be used in accordance with BS EN 60598.2.22)
- Ideal for task lighting projects where normal (high) lighting levels are required to minimise business disruption
- High efficiency: Low running cost
 1. This AC/AC type of system has been designed for an inherently long service life with associated significant cost benefits over alternative emergency lighting solutions
- Cost conservancy and design:
 1. Ventilation fan life is maximised, as they will only operate when required, during 'battery charge' or 'inverter active' cycles
 2. Battery life conserved by a temperature compensated constant voltage charger circuit in conjunction with passive stand-by inverter operation
- Functional features include sub-circuit monitoring, final exit input, MCB monitoring, M/NM operation (user selectable), fire alarm input and two volt-free common alarm outputs
- MCB protection devices are used throughout the equipment, eliminating the need for fuse spares
- Digital display for battery and output metering V & I
- Fully compliant with EN 50171 and ICEL1009
- EMEX TS includes integral touch-screen with EMEX Test capability



Central power supplies

EMEX Range

2



EMEX110 – AC/DC Central Power Supply Systems: 110 V

The 'EMEX110' range is available where the user preference is for an AC/DC system powering slave luminaires fitted with compatible inverter modules. The 110 V range is suitable for medium to large premises, including schools, supermarkets and other commercial or local authority properties.

Structurally, the type enjoys the modular design and all the standard features of the EMEX range.



Emergi-Lite EMEX AC/AC CPS systems are now kitemark approved to EN 50171 (Kitemark reference KM 542294).



EMEX Test

An optional innovative test facility is available for testing both the central power supply system and emergency lighting luminaires linked to it. The 'EMEX Test' hardware and software has been developed to produce an advanced, reliable and functional system at comparatively low cost. Data communication to the luminaires being fed from the inverter is available in two forms depending on user choice. Either a Data Bus version utilising a single pair data cable or a line borne data signal imposed onto distributed AC power is available.

- Both the central power supply and luminaires are addressable
- Programmable: To perform timed tests during 'out of hours' periods for minimal disruption to everyday core business
- Any failure is recorded to a printable log file
- User interface: A standard PC with printer or door mounted touch-screen
- Networking facility: Up to 256 separate systems can be networked for testing from a single PC
- Remote access: Test results can be viewed remotely via computer network/internet
- A substation (MXC) is used to control up to 40 luminaires
- Additionally, any standard luminaire can be converted for use with substations using a small LTC interface module
- Test and monitoring facility designed as per EN50172/IEC 62034 guidelines

Compact power ac/dc central Power Supply Systems

Light and medium duty 24 V or 50 V for smaller premises or replacement work. Full range of options available to suit site and customer requirements.

For a project assessment, design and quotation please contact a member of our internal Technical Sales or Field Sales Team. We will be able to offer the most suitable equipment for your local requirement.



Central power supplies

Technical reference

Testing

BS 5266 Part 8 (EN 50172) and BS EN 62034:2000 specify the statutory requirements for testing the entire emergency lighting installation, and a copy of this standard should be obtained.

It should be noted that, immediately after a test, the battery might not have sufficient capacity to provide emergency lighting cover. For this reason all tests should be performed, where possible, at a time of minimum risk.

Record keeping

It is a requirement of BS 5266 Part 8 (EN 50172) that accurate records of testing are kept. Emergi-Lite have produced an Emergency Lighting Record Log Book designed to assist with these requirements. These are available to order – part code YLB-EL0807.

General maintenance

Check the system has adequate ventilation. Louvres in the door, and grilles in the rear panel must not be obstructed. Door access must not be obstructed. The operating environment should be free from dust, which can accumulate inside modules.

Charger maintenance

The charger output voltage should be tested on a monthly basis by a competent engineer to ensure it is set correctly. Charger voltage may be affected by the ambient temperature in the battery compartment. Any variation in charger voltage should be noted, and, if in doubt, contact Emergi-Lite Service Department for advice and assistance. Equipment should be maintained dust free and clean to prevent premature failure.

Battery and cells maintenance and storage

Battery storage, maintenance and handling shall be fully carried out in line with the battery manufacturers instructions. The battery should be visually inspected each month by a competent engineer to check that there is no evidence of damaged or leaking cells. Damaged or leaking cells require replacement. Please contact Emergi-Lite Service Department for advice and replacements. Individual cell voltages should be recorded on the record sheets provided in the manual. A digital DC voltmeter is required for this purpose. Only record cell voltages when the battery is fully charged, which takes a maximum of 24 hrs after a test.

Cell voltages should remain constant over the life of the battery. Cells showing a voltage differing from previous readings require investigation (please note charger is temperature compensated and cell voltages will vary with ambient room temperature changes). Do not at any time attempt to remove or replace cells or re-commission the system. Please contact Emergi-Lite Service Department for advice and assistance. Temperature extremes severely affect battery life. Always check and record the ambient temperature in the battery room. The optimum temperature is 20°C.

Handling

Most cells are heavy and difficult to handle. Care should be taken and the correct technique employed when using manual or other lifting methods.

Explosion hazard

Recombination (sealed) cells, when operated correctly, have negligible rates of gas evolution.

Repair/disposal

No attempt should be made to repair any cells, they should be treated as disposable when they have outlived their use. Batteries must be disposed of in accordance with current waste disposal and pollution legislation. It is recommended that the following authorities are contacted before any attempt is made to dispose of cells; Environment Agency Local Office, Local Authority Environmental Health or Waste Handling Department.

Our Service Department is available to provide advice regarding disposal of batteries, replacement of batteries and re-commissioning of Central Power Supply Systems. Please contact us for assistance.

Warranty

Failure to observe above guidance may invalidate the Thomas and Betts warranty. Terms and conditions of warranty apply which are available on request.



Guideway Innovative & stylish

- Injection moulded - aluminium base construction
- Bright & uniform light distribution with 500 cd/m²
- Versatile mounting options with First-Fix control gear
- Unique frameless legend design with click-lock assembly

Guideway

Innovative & stylish



Guideway 22m - Recessed

- Injection moulded - aluminium base construction
- Bright & uniform light distribution with 500 cd/sq.m
- Versatile mounting options with First-Fix control gear
- Unique frameless legend design with click-lock assembly

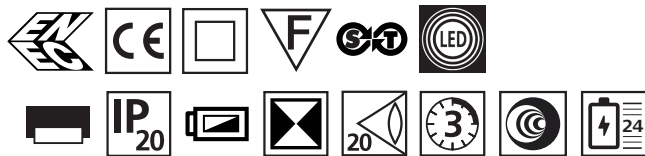

Luminaire

Order code	Input Voltage	Description	Lamp type	Power Consumption	Operation / Duration (hrs)	Environment Temperature	Weight
EGR3LS1-S22	220-240Vac, 50 Hz	LED SIGN M3 RECESSED	LED strip 1,8W	18,3 mA	M3	5-35 °C	0.93 kg
CTEGR3LS1-S22	220-240Vac, 50 Hz	LED SIGN M3 RECESSED, CT-NAVEO	LED strip 1,8W	18,3 mA	M3	5-35 °C	0.93 kg
EGR1LS1-S22	220-240Vac, 50 Hz	LED SIGN 230V HF RECESSED	LED strip 1,8W	18,3 mA	230 V	0-35 °C	0.93 kg
EGR1LS1LTC-S22	220-240Vac, 50 Hz	LED SIGN 230V EMEX TEST RECESSED	LED strip 1,8W	18,3 mA	230 V	0-35 °C	0.93 kg

For testing and dimmable control assemblies, please contact Emergi-lite

Legends are screen printed. ISO 7010 format legends shown. Euro pictogram legends are available to order, please contact Emergi-Lite

'60Hz' option available on request, please contact Emergi-lite.

Designed and manufactured to meet the requirements of BS EN 60598.2.22

Part No.	Legends
XEN2EG22	
XEN3EG22	
XEN6EG22	
XEN5EG22	
XEN602EG22	
XEN603EG22	
XEN606EG22	
XEN605EG22	
Arabic legend format	
XBN1EG22	



Accessories

Order code	Description	Colour
EG-T4SG	Cover discs, 2+2 selfcon	
EG-T4EG	Cover discs, 2+2 slave	

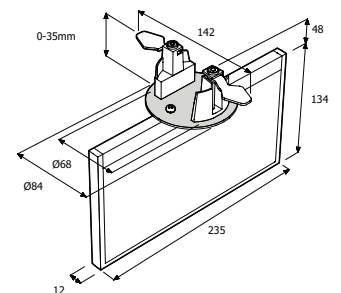

Guideway

Innovative & stylish

3



Guideway 32m - Recessed

- Injection moulded - aluminium base construction
- Bright & uniform light distribution with 500 cd/sq.m
- Versatile mounting options with First-Fix control gear
- Unique frameless legend design with click-lock assembly

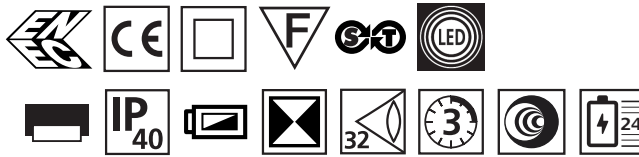

Luminaire

Order code	Input Voltage	Description	Lamp type	Power Consumption	Operation / Duration (hrs)	Recharge Period	Environment Temperature	Weight
EGR3LS1-S32	220-240Vac, 50 Hz	LED SIGN M3 RECESSED	LED strip 3,6W	26,1 mA	M3	24 hrs	5-35 °C	1,11 kg
CTEGR3LS1-S32	220-240Vac, 50 Hz	LED SIGN M3 RECESSED, CT-NAVEO	LED strip 3,6W	26,1 mA	M3	24 hrs	5-35 °C	1,11 kg
EGR1LS1-S32	220-240Vac, 50 Hz	LED SIGN 230V HF RECESSED	LED strip 3,6W	27,4 mA	230 V	24 hrs	0-35 °C	1,29 kg
EGR1LS1LTC-S32	220-240Vac, 50 Hz	LED SIGN 230V EMEX TEST RECESSED	LED strip 3,6W	27,4mA	230 V	24 hrs	0-35 °C	1,29 kg

For testing and dimmable control assemblies, please contact Emergi-lite

Legends are screen printed. ISO 7010 format legends shown. Euro pictogram legends are available to order, please contact Emergi-Lite

'60Hz' option available on request, please contact Emergi-lite.

Designed and manufactured to meet the requirements of BS EN 60598.2.22

Part No.	Legends
XEN2EG22	
XEN3EG22	
XEN6EG22	
XEN5EG22	
XEN602EG22	
XEN603EG22	
XEN606EG22	
XEN605EG22	
Arabic legend format	
XBN1EG32	



Accessories

Order code	Description	Colour
EG-T4SG	Cover discs, 2+2 selfcon	
EG-T4EG	Cover discs, 2+2 slave	

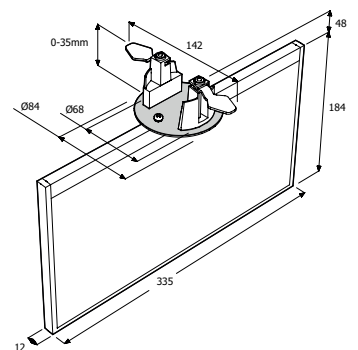

Guideway

Innovative & stylish



Guideway 22m - Surface

- Injection moulded - aluminium base construction
- Bright & uniform light distribution with 500 cd/sq.m
- Versatile mounting options with First-Fix control gear
- Unique frameless legend design with click-lock assembly



Luminaire

Order code	Input Voltage	Description	Lamp type	Power Consumption	Operation / Duration (hrs)	Recharge Period	Environment Temperature	Weight
EG3LS1-S22	220-240Vac, 50 Hz	LED SIGN M3 SURFACE MOUNT	LED strip 1,8W	18,3 mA	M3	24 hrs	5-35 °C	1,11 kg
CTEG3LS1-S22	220-240Vac, 50 Hz	LED SIGN M3 SURFACE MOUNT, CT-NAVEO	LED strip 1,8W	18,3 mA	M3	24 hrs	5-35 °C	1,11 kg
EG1LS1-S22	220-240Vac, 50 Hz	LED SIGN 230V HF SURFACE MOUNT	LED strip 1,8W	18,3 mA	230 V	24 hrs	0-35 °C	1,00 kg
EG1LS1LTC-S22	220-240Vac, 50 Hz	LED SIGN 230V EMEX TEST SURFACE MOUNT	LED strip 1,8W	18,3 mA	230 V	24 hrs	0-35 °C	1,00 kg

Includes back to wall mounting accessory as standard

For testing and dimmable control assemblies, please contact Emergi-lite

Legends are screen printed. ISO 7010 format legends shown. Euro pictogram legends are available to order, please contact Emergi-Lite

'60Hz' option available on request, please contact Emergi-lite.

Designed and manufactured to meet the requirements of BS EN 60598.2.22

Part No.	Legends
XEN2EG22	
XEN3EG22	
XEN6EG22	
XEN5EG22	
XEN602EG22	
XEN603EG22	
XEN606EG22	
XEN605EG22	
Arabic legend format	
XBN1EG22	



Accessories

Order code	Description
EG-TKIT50	Tube suspension kit (0.5 m)
EG-TKIT100	Tube suspension kit (1 m)

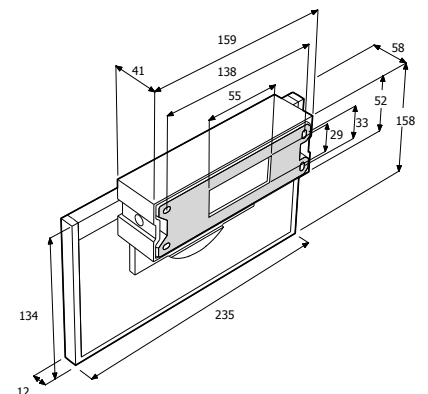

Guideway

Innovative & stylish



Luminaire

Guideway 32m - Surface

- Injection moulded - aluminium base construction
- Bright & uniform light distribution with 500 cd/sq.m
- Versatile mounting options with First-Fix control gear
- Unique frameless legend design with click-lock assembly

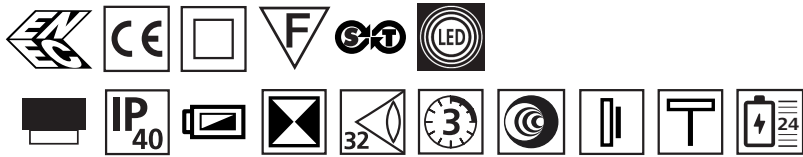

Order code	Input Voltage	Description	Lamp type	Power Consumption	Operation / Duration (hrs)	Environment Temperature	Weight
EG3LS1-S32	220-240Vac, 50 Hz	LED SIGN M3 SURFACE MOUNT	LED strip 3,6W	26,1 mA	M3	5-35 °C	1,58 kg
CTEG3LS1-S32	220-240Vac, 50 Hz	LED SIGN M3 SURFACE MOUNT, CT-NAVEO	LED strip 3,6W	26,1 mA	M3	5-35 °C	1,58 kg
EG1LS1-S32	220-240Vac, 50 Hz	LED SIGN 230V HF SURFACE MOUNT	LED strip 3,6W	27,4 mA	230 V	0-35 °C	1,48 kg
EG1LS1LTC-S32	220-240Vac, 50 Hz	LED SIGN 230V EMEX TEST SURFACE MOUNT	LED strip 3,6W	27,4 mA	230 V	0-35 °C	1,48 kg

Includes back to wall mounting accessory as standard

For testing and dimmable control assemblies, please contact Emergi-lite

Legends are screen printed. ISO 7010 format legends shown. Euro pictogram legends are available to order, please contact Emergi-Lite

'60Hz' option available on request, please contact Emergi-lite

Designed and manufactured to meet the requirements of BS EN 60598.2.22

Part No.	Legends
XEN2EG22	
XEN3EG22	
XEN6EG22	
XEN5EG22	
XEN602EG22	
XEN603EG22	
XEN606EG22	
XEN605EG22	
Arabic legend format	
XBN1EG32	



Accessories

Order code	Description
EG-TKIT50	Tube suspension kit (0.5 m)
EG-TKIT100	Tube suspension kit (1 m)

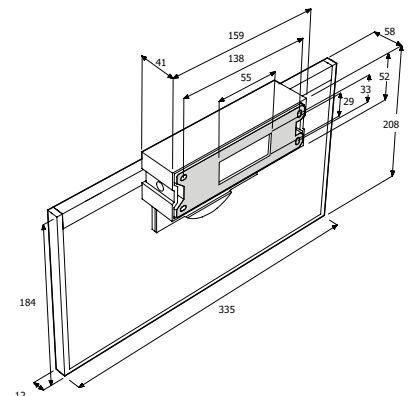

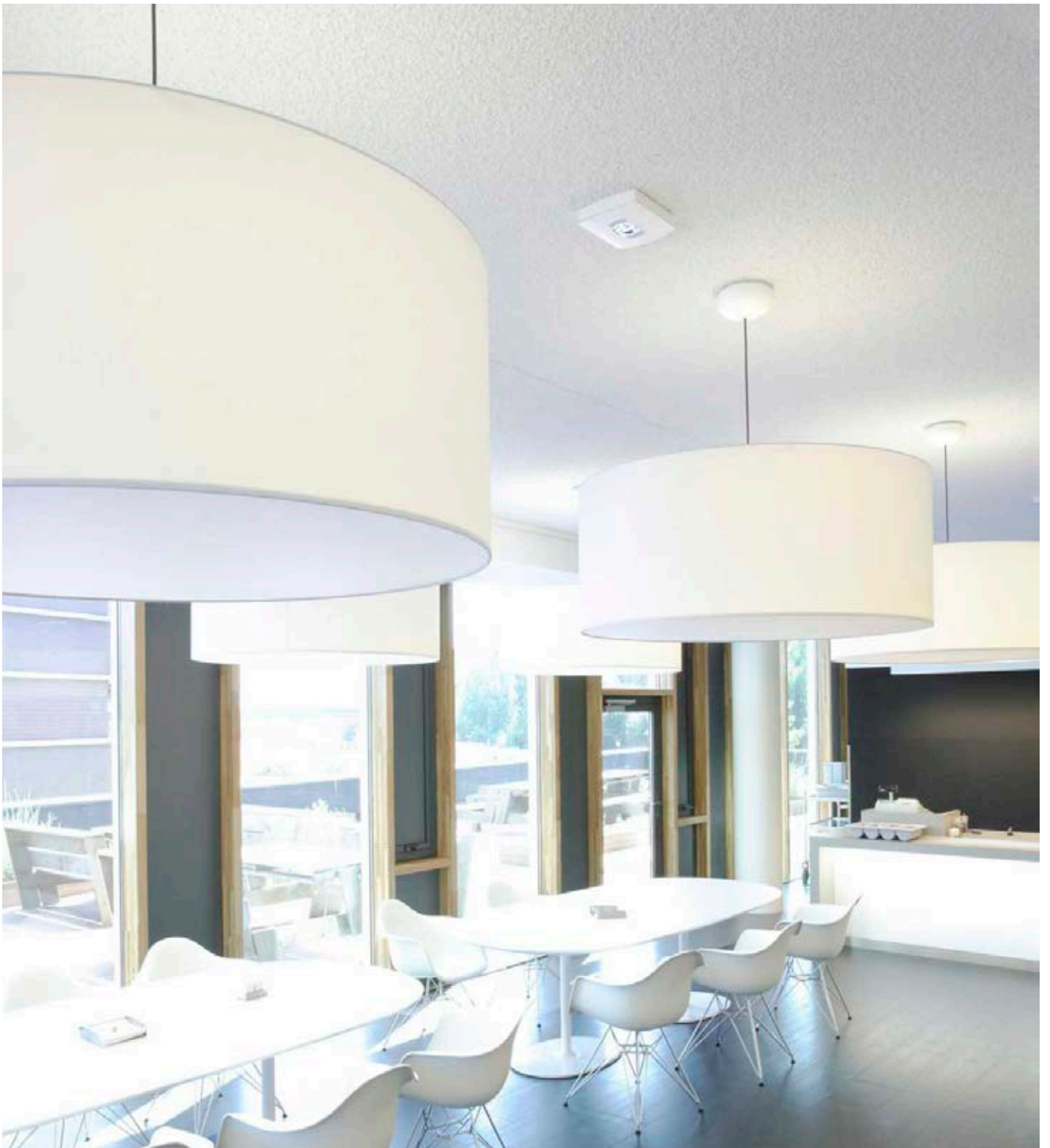

Serenga

Project covering & stylish

- High power, low energy consumption LED solutions
- Specially designed lens for optimized light distribution
- Modular, First-Fix installation
- 2 different shapes to suit interior design requirements

Serenga

Project covering & stylish



Escape route - Recessed (long beam)

- Injection moulded - high grade polycarbonate body
- Specially designed lens for optimised light distribution
- Modular, First-Fix installation
- Available in 2 different shapes to suite interior design capabilities

4

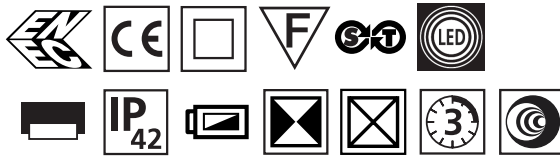

Luminaire

Order code	Input Voltage	Description	Lamp type	Lamp Output	Power Consumption	Operation / Duration (hrs)	Recharge Period	Environment Temperature	Weight
SR2-DEA-M3	220-240Vac, 50 Hz	REC M3 AUTOTST ESC-4MH WH	2 x LED 0,85W	177 lm	21mA	M3	24 hrs	5-40 °C	0,6 kg
CTSR2-DEA-M3	220-240Vac, 50 Hz	REC M3 CT-NAVEO ESC-L4M WH	2 x LED 0,85W	177 lm	21mA	M3	24 hrs	5-40 °C	0,6 kg
SR2-DEA-230HF	220-240Vac, 50 Hz	REC 230V ESC-L4M WH	2 x LED 0,85W	200 lm	23mA	230 V	-	0-40 °C	0,3 kg
SR2-DEA-230LTC	220-240Vac, 50 Hz	REC 230V EMEX ESC-L4M WH	2 x LED 0,85W	200 lm	23mA	230 V	-	0-40 °C	0,3 kg
SR2Q-DEA-M3	220-240Vac, 50 Hz	REC-SQ M3 AUTOTST ESC-L4M WH	2 x LED 0,85W	177 lm	21mA	M3	24 hrs	5-40 °C	0,6 kg
CTSR2Q-DEA-M3	220-240Vac, 50 Hz	REC-SQ M3 CT-NAVEO ESC-L4M WH	2 x LED 0,85W	177 lm	21mA	M3	24 hrs	5-40 °C	0,6 kg
SR2Q-DEA-230HF	220-240Vac, 50 Hz	REC-SQ 230V ESC-L4M WH	2 x LED 0,85W	200 lm	23mA	230 V	-	0-40 °C	0,3 kg
SR2Q-DEA-230LTC	220-240Vac, 50 Hz	REC-SQ 230V EMEX ESC-L4M WH	2 x LED 0,85W	200 lm	23mA	230 V	-	0-40 °C	0,3 kg

Designed and manufactured to meet the requirements of BS EN 60598.2.22



Accessories

Order code	Description
SR2-CCAW	WH CIRCULAR ADAPTOR
SR2-LENS2	LENS KIT FOR 6 - 10M

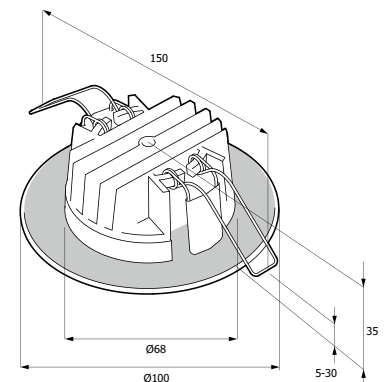

Serenga

Project covering & stylish



Emergency spot light - Recessed (object lighting)

- Injection moulded - high grade polycarbonate body
- Specially designed lens for optimised light distribution
- Modular, First-Fix installation
- Available in 2 different shapes to suite interior design capabilities

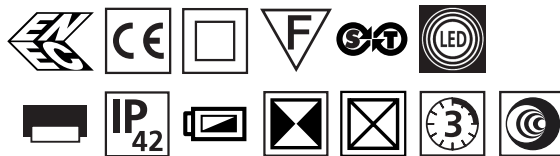

Luminaire

Order code	Input Voltage	Description	Lamp type	Lamp Output	Power Consumption	Operation / Duration (hrs)	Recharge Period	Environment Temperature	Weight
SR2-DS-RM3	220-240Vac, 50 Hz	REC M3 AUTOTST SPOT-L4M WH	2 x LED 0,85W	200 lm	21mA	M3	24 hrs	5-40 °C	0,6 kg
CTSR2-DS-RM3	220-240Vac, 50 Hz	REC M3 CT-NAVEO SPOT-L4M WH	2 x LED 0,85W	200 lm	21mA	M3	24 hrs	5-40 °C	0,6 kg
SR2-DS-R230HF	220-240Vac, 50 Hz	REC 230V SPOT-L4M WH	2 x LED 0,85W	230 lm	23mA	230 V	-	0-40 °C	0,3 kg
SR2-DS-R230LTC	220-240Vac, 50 Hz	REC 230V EMEX SPOT-L4M WH	2 x LED 0,85W	230 lm	23mA	230 V	-	0-40 °C	0,3 kg
SR2-DQS-RM3	220-240Vac, 50 Hz	REC-SQ M3 AUTOTST SPOT-L4M WH	2 x LED 0,85W	200 lm	21mA	M3	24 hrs	5-40 °C	0,6 kg
CTSR2-DQS-RM3	220-240Vac, 50 Hz	REC-SQ M3 CT-NAVEO SPOT-L4M WH	2 x LED 0,85W	200 lm	21mA	M3	24 hrs	5-40 °C	0,6 kg
SR2-DQS-R230HF	220-240Vac, 50 Hz	REC-SQ 230V SPOT-L4M WH	2 x LED 0,85W	230 lm	23mA	230 V	-	0-40 °C	0,3 kg
SR2-DQS-R230LTC	220-240Vac, 50 Hz	REC-SQ 230V EMEX SPOT-L4M WH	2 x LED 0,85W	230 lm	23mA	230 V	-	0-40 °C	0,3 kg

Designed and manufactured to meet the requirements of BS EN 60598.2.22



Accessories

Order code	Description
SR2-CCAW	WH CIRCULAR ADAPTOR
SR2-LENS2	LENS KIT FOR 6 - 10M

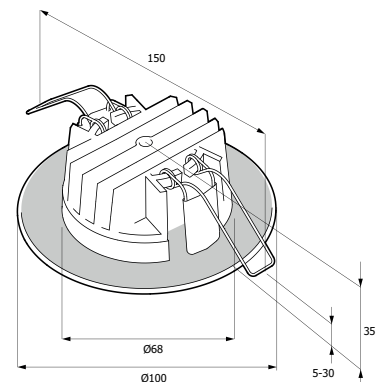

Serenga

Project covering & stylish



Anti-panic lighting - Recessed (wide beam)

- Injection moulded - high grade polycarbonate body
- Specially designed lens for optimised light distribution
- Modular, First-Fix installation
- Available in 2 different shapes to suite interior design capabilities

4

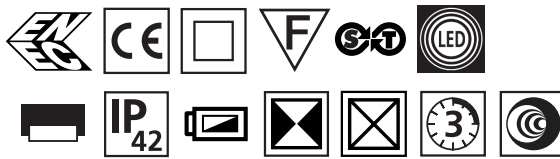

Luminaire

Order code	Input Voltage	Description	Lamp type	Lamp Output	Power Consumption	Operation / Duration (hrs)	Recharge Period	Environment Temperature	Weight
SR2-DAD-M3	220-240Vac, 50 Hz	REC M3 AUTOTST OA-L4M WH	2 x LED 0,85W	215 lm	21mA	M3	24 hrs	5-40 °C	0,6 kg
CTSR2-DAD-M3	220-240Vac, 50 Hz	REC M3 CT-NAVEO OA-L4M WH	2 x LED 0,85W	215 lm	21mA	M3	24 hrs	5-40 °C	0,6 kg
SR2-DAD-230HF	220-240Vac, 50 Hz	REC 230V OA-L4M WH	2 x LED 0,85W	245 lm	23mA	230 V	-	0-40 °C	0,3 kg
SR2-DAD-230LTC	220-240Vac, 50 Hz	REC 230V EMEX OA-L4M WH	2 x LED 0,85W	245 lm	23mA	230 V	-	0-40 °C	0,3 kg
SR2Q-DAD-M3	220-240Vac, 50 Hz	REC-SQ M3 AUTOTST OA-L4M WH	2 x LED 0,85W	215 lm	21mA	M3	24 hrs	5-40 °C	0,6 kg
CTSR2Q-DAD-M3	220-240Vac, 50 Hz	REC-SQ M3 CT-NAVEO OA-L4M WH	2 x LED 0,85W	215 lm	21mA	M3	24 hrs	5-40 °C	0,6 kg
SR2Q-DAD-230HF	220-240Vac, 50 Hz	REC-SQ 230V OA-L4M WH	2 x LED 0,85W	245 lm	23mA	230 V	-	0-40 °C	0,3 kg
SR2Q-DAD-230LTC	220-240Vac, 50 Hz	REC-SQ 230V EMEX OA-L4M WH	2 x LED 0,85W	245 lm	23mA	230 V	-	0-40 °C	0,3 kg

Designed and manufactured to meet the requirements of BS EN 60598.2.22



Accessories

Order code	Description
SR2-CCAW	WH CIRCULAR ADAPTOR
SR2-LENS2	LENS KIT FOR 6 - 10M

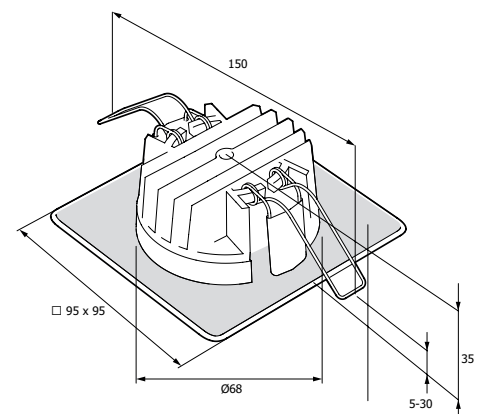

Serenga

Project covering & stylish



Escape route - Surface mount (long beam)

- Injection moulded - high grade polycarbonate body
- Specially designed lens for optimised light distribution
- Modular, First-Fix installation
- Ease of installation - unique moulded construction to retain IP rating without additional protection

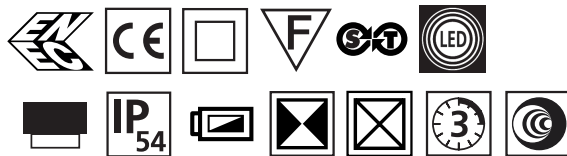

Luminaire

Order code	Input Voltage	Description	Lamp type	Lamp Output	Power Consumption	Operation / Duration (hrs)	Recharge Period	Environment Temperature	Weight
SR2-SEM3-A1	220-240Vac, 50 Hz	SFC M3 AUTOTST ESC-L4M WH	2 x LED 0,85W	177 lm	21mA	M3	24 hrs	5-40 °C	1,0 kg
CTSR2-SEM3-A1	220-240Vac, 50 Hz	SFC M3 CT-NAVEO ESC-L4M WH	2 x LED 0,85W	177 lm	21mA	M3	24 hrs	5-40 °C	1,0 kg
SR2-SE230HF-A1	220-240Vac, 50 Hz	SFC 230V ESC-L4M WH	2 x LED 0,85W	200 lm	23mA	230 V	-	0-40 °C	0,75 kg
SR2-SE230LTC-A1	220-240Vac, 50 Hz	SFC 230V EMEX ESC-L4M WH	2 x LED 0,85W	200 lm	23mA	230 V	-	0-40 °C	0,75 kg

Designed and manufactured to meet the requirements of BS EN 60598.2.22



Accessories

Order code	Description
SR2-LENS2	LENS KIT FOR 6 - 10M

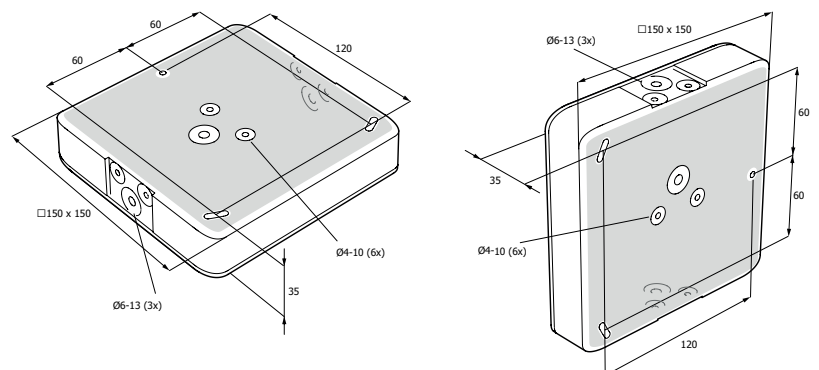

Serenga

Project covering & stylish



Anti-panic - Surface mount (wide beam)

- Injection moulded - high grade polycarbonate body
- Specially designed lens for optimised light distribution
- Modular, First-Fix installation
- Ease of installation - unique moulded construction to retain IP rating without additional protection

4

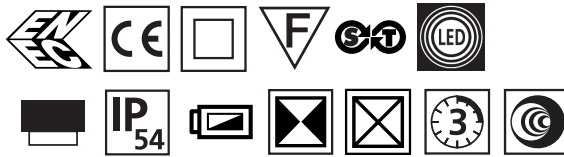

Luminaire

Order code	Input Voltage	Description	Lamp type	Lamp Output	Power Consumption	Operation / Duration (hrs)	Recharge Period	Environment Temperature	Weight
SR2-SAM3-D1	220-240Vac, 50 Hz	SFC M3 AUTOTST OA-L4M WH	2 x LED 0,85W	215 lm	21mA	M3	24 hrs	5-40 °C	1,0 kg
CTSR2-SAM3-D1	220-240Vac, 50 Hz	SFC M3 CT-NAVEO OA-L4M WH	2 x LED 0,85W	215 lm	21mA	M3	24 hrs	5-40 °C	1,0 kg
SR2-SA230HF-D1	220-240Vac, 50 Hz	SFC 230V OA-L4M WH	2 x LED 0,85W	245 lm	23mA	230 V	-	0-40 °C	0,75 kg
SR2-SA230LTC-D1	220-240Vac, 50 Hz	SFC 230V EMEX OA-L4M WH	2 x LED 0,85W	245 lm	23mA	230 V	-	0-40 °C	0,75 kg

Designed and manufactured to meet the requirements of BS EN 60598.2.22



Accessories

Order code	Description
SR2-LENS2	LENS KIT FOR 6 - 10M

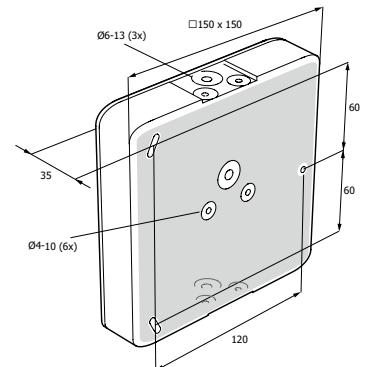
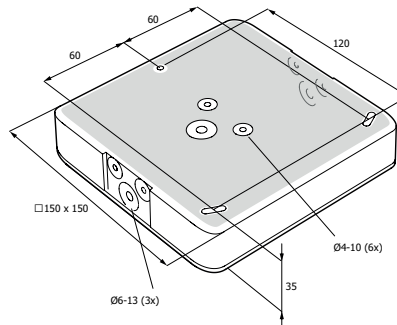

Serenga

Project covering & stylish



Escape route - Surface mount 12m (long beam)

- Injection moulded - high grade polycarbonate body
- Specially designed lens for optimised light distribution - ideal for high ceiling areas, up to 12 meter
- Modular, First-Fix installation
- Ease of installation - unique moulded construction to retain IP rating without additional protection

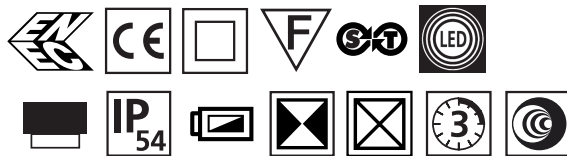

Luminaire

Order code	Input Voltage	Description	Lamp type	Lamp Output	Power Consumption	Operation / Duration (hrs)	Recharge Period	Environment Temperature	Weight
SR2-SEM3-BC1	220-240Vac, 50 Hz	AUTOTST SFC ESC-MH12M 2L M3	2 x LED 0,85W	210 lm	21mA	M3	24 hrs	5-40 °C	1,0 kg
CTSR2-SEM3-BC1	220-240Vac, 50 Hz	CT-N SFC ESC-MH12M 2L M3	2 x LED 0,85W	210 lm	21mA	M3	24 hrs	5-40 °C	1,0 kg
SR2-SE230HF-BC1	220-240Vac, 50 Hz	SFC ESC-MH12M 2L 230V50Hz	2 x LED 0,85W	240 lm	23mA	230 V	-	0-40 °C	0,75 kg
SR2-SE230LT-BC1	220-240Vac, 50 Hz	SFACE ESC-MH12M 2L 230V50Hz LTC WH	2 x LED 0,85W	240 lm	23mA	230 V	-	0-40 °C	0,75 kg

Designed and manufactured to meet the requirements of BS EN 60598.2.22

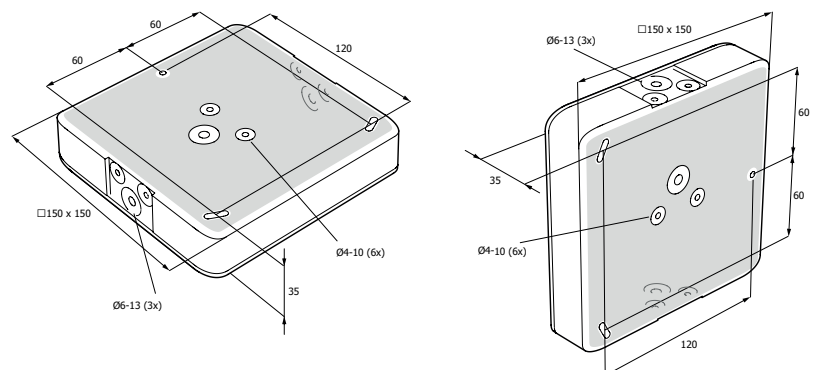

Serenga

Project covering & stylish



Anti-panic - Surface mount 12m (wide beam)

- Injection moulded - high grade polycarbonate body
- Specially designed lens for optimised light distribution - Ideal for high ceiling areas, up to 12 meter
- Modular, First-Fix installation
- Ease of installation - unique moulded construction to retain IP rating without additional protection

4

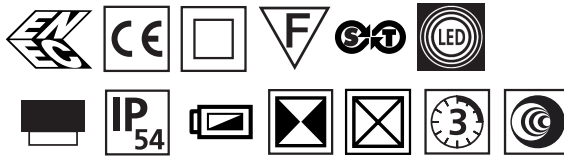

Luminaire

Order code	Input Voltage	Description	Lamp type	Lamp Output	Power Consumption	Operation / Duration (hrs)	Recharge Period	Environment Temperature	Weight
SR2-SAEM3-EF1	220-240Vac, 50 Hz	AUTOTST SFC OA-MH12M 2L M3	2 x LED 0,85W	205 lm	21mA	M3	24 hrs	5-40 °C	1,0 kg
CTSR2-SAM3-EF1	220-240Vac, 50 Hz	CT-N SFC OA-MH12M 2L M3	2 x LED 0,85W	205 lm	21mA	M3	24 hrs	5-40 °C	1,0 kg
SR2-SA230HF-EF1	220-240Vac, 50 Hz	SFC OA-MH12M 2L 230V50HZ	2 x LED 0,85W	235 lm	23mA	230 V	-	0-40 °C	0,75 kg
SR2-SA230LTC-EF1	220-240Vac, 50 Hz	SFACE OA-MH12M 2L 230V50HZ LTC WH	2 x LED 0,85W	235 lm	23mA	230 V	-	0-40 °C	0,75 kg

Designed and manufactured to meet the requirements of BS EN 60598.2.22

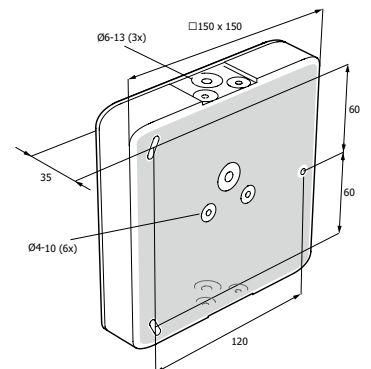
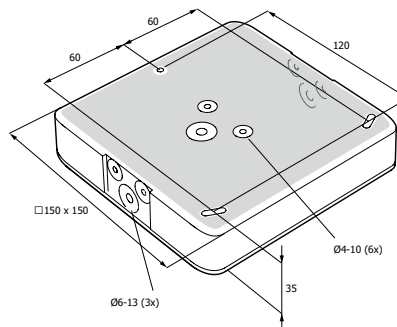

Serenga

Project covering & stylish



Escape route - Surface mount wall

- Injection moulded- high grade polycarbonate body
- Specially designed lens with optimised light distribution for wall mounting applications
- Modular, First-Fix installation
- Ease of installation - unique moulded construction to retain IP rating without additional protection

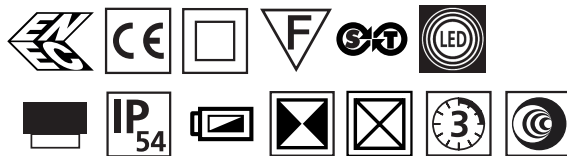

Luminaire

Order code	Input Voltage	Description	Lamp type	Lamp Output	Power Consumption	Operation / Duration (hrs)	Recharge Period	Environment Temperature	Weight
SR2-SWM3-G1	220-240Vac, 50 Hz	SFC M3 AUTOTST WALL -W3M WH	2 x LED 0,85W	180 lm	21mA	M3	24 hrs	5-40 °C	1,0 kg
CTSR2-SWM3-G1	220-240Vac, 50 Hz	SFC M3 CT-NAVEO WALL -W3M WH	2 x LED 0,85W	180 lm	21mA	M3	24 hrs	5-40 °C	1,0 kg
SR2-SW230HF-G1	220-240Vac, 50 Hz	SFC 230V WALL -W3M WH	2 x LED 0,85W	210 lm	23mA	230 V	-	0-40 °C	0,75 kg
SR2-SW230LTC-G1	220-240Vac, 50 Hz	SFC 230V EMEX WALL -W3M WH	2 x LED 0,85W	210 lm	23mA	230 V	-	0-40 °C	0,75 kg

Designed and manufactured to meet the requirements of BS EN 60598.2.22

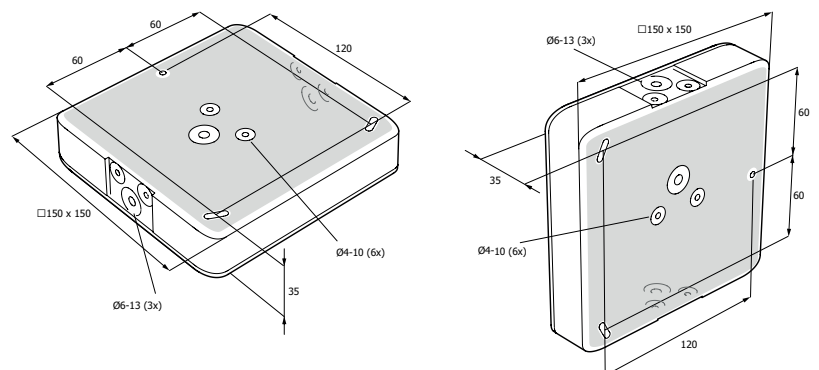



Serenga Contemporary & economical

- Modular, first-fix installation with optional mounting accessories
- Exit smart frame with 2 LED or 4 LED
- High power, lower energy consumption LED solutions
- 2 surface mount orientations

Serenga

Contemporary & economical



LED escape route illumination, plastic frame, aluminium trim
Normal legend face

- 2 surface mount orientations
- 2 LED exit sign or 4 LED (2-downlighters) exit sign
- First-Fix with optional mounting accessories
- High grade polycarbonate body with aluminium trim

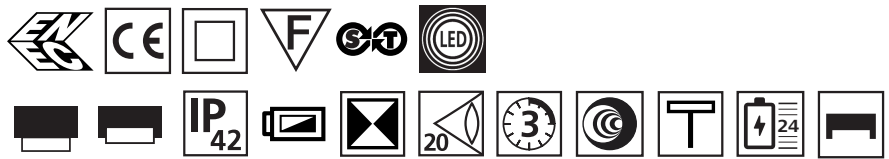

Control assembly

Order code	Input Voltage	Description	Operation / Duration (hrs)	Recharge Period	Environment Temperature	Weight
SER-M3-003	220 - 240 Vac, 50 Hz	SERENGA M3 CNTRL MODULE & BATT PACK, 50Hz	M3	24 hrs	5-25 °C	0.8 kg
CTSER-M3V2-003	220 - 240 Vac, 60 Hz	SERENGA M3 CNTRL MODULE & BATT PACK, CT VERSION, 50 Hz	M3	24 hrs	5-25 °C	0.8 kg
CTSER-M3EV2-003	220 - 240 Vac, 60 Hz	SERENGA M3 CNTRL MODULE & BATT PACK, CT VERSION, 60 Hz	M3	24 hrs	5-25 °C	0.8 kg
SER-M3EV2-003	220 - 240 Vac, 50 Hz	SERENGA M3 CNTRL MODULE & BATT PACK, 60Hz	M3	24 hrs	5-25 °C	0.8 kg
SER-230-003	85 - 240 Vac, 50 Hz	SERENGA CONTROL MODULE 230V MAINS	230 V	-	0-40 °C	0.8 kg
SER-230LTC-003	85 - 240 Vac, 50Hz	SERENGA CONTROL MODULE 230V, LTC VERSION	230 V	-	0-40 °C	0.8 kg

Smart- Frame

Order code	Lamp type	Description	Power Consumption Self Contained	Power Consumption Slave	Weight
SER-FE2D	2 x 1W LED	SERENGA SMART FRAME 2 LED - NORMAL FACE	60 mA	30 mA	0.9 kg
SER-FE4D	4 x 1W LED	SERENGA SMART FRAME 4 LED - NORMAL FACE	70 mA	60 mA	0.9 kg
SER-FE2DS	2 x 1W LED (Side Wired)	SERENGA SMART FRAME 2 LED - NORMAL FACE/ FLAG FORMAT	60 mA	30 mA	0.9 kg
SER-FE4DS	4 x 1W LED (Side Wired)	SERENGA SMART FRAME 4 LED - NORMAL FACE/ FLAG FORMAT	70 mA	60 mA	0.9 kg

For testing and dimmable control assemblies, please contact Emergi-lite

Legends are screen printed. ISO 7010 format legends shown. Euro pictogram legends are available to order, please contact Emergi-Lite

Includes legend down-blank. Designed and manufactured to meet the requirements of BS EN 60598.2.22

Part No.	Legends
European signs directive, SI341 format	
SER-SN010	
SER-SN011	
SER-SN012	
SER-SN013	
ISO 7010 legend format	
SER-SNN10	
SER-SNN11	
SER-SNN12	
SER-SNN13	
Arabic legend format	
SER-SNB01	
Safety signs	
SER-SN802	
SER-SN803	

Accessories

Order code	Description
SER-BZKIT	RECESSING KIT
SER-RKIT150	TUBE SUSPENSION KIT (0.15 M)
SER-RKIT300	TUBE SUSPENSION KIT (0.3 M)
SER-RKIT500	TUBE SUSPENSION KIT (0.5 M)
SER-RKIT1000	TUBE SUSPENSION KIT (1 M)

For further information on Naveo and IR2 emergency luminaire testing formats, please contact Emergi-Lite

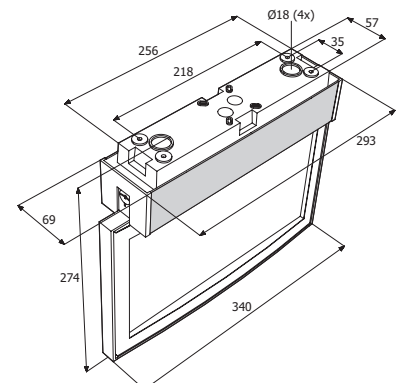

Serenga

Contemporary & economical



LED escape route illumination, plastic frame, aluminium trim
(C model = CURVED on both sides)

- 2 surface mount orientations
- 2 LED exit sign or 4 LED exit sign with downlighters
- First-Fix with optional mounting accessories
- High grade polycarbonate body with aluminium trim

4

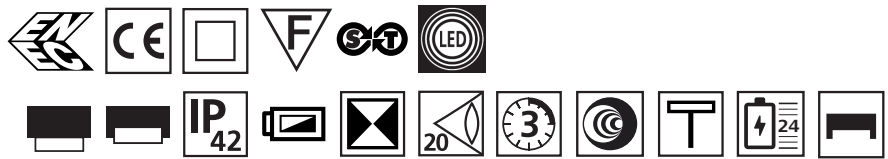

Control assembly

Order code	Input Voltage	Description	Operation / Duration (hrs)	Recharge Period	Environment Temperature	Weight
SER-M3-003	220 - 240 Vac, 50 Hz	SERENGA M3 CNTRL MODULE & BATT PACK, 50Hz	M3	24 hrs	5-25 °C	0.8 kg
CTSER-M3-003	220 - 240 Vac, 50 Hz	SERENGA M3 CNTRL MODULE & BATT PACK, CT VERSION, 50 Hz	M3	24 hrs	5-25 °C	0.8 kg
CTSER-M3EV2-003	220 - 240 Vac, 60 Hz	SERENGA M3 CNTRL MODULE & BATT PACK, CT VERSION, 60 Hz	M3	24 hrs	5-25 °C	0.8 kg
SER-M3EV2-003	220 - 240 Vac, 60 Hz	SERENGA M3 CNTRL MODULE & BATT PACK, 60Hz	M3	24 hrs	5-25 °C	0.8 kg
SER-230-003	85 - 240 Vac, 50 Hz	SERENGA CONTROL MODULE 230V MAINS	230 V	-	0-40 °C	0.8 kg
SER-230LTC-003	85 - 240 Vac, 50 Hz	SERENGA CONTROL MODULE 230V, LTC VERSION	230 V	-	0-40 °C	0.8 kg

Smart- Frame

Order code	Lamp type	Description	Power Consumption Self Contained	Power Consumption Slave	Weight
SER-FS2D	2 x 1W LED	SERENGA SMART FRAME 2 LED - CURVED FACE	60 mA	30 mA	0.9 KG
SER-FS4D	4 x 1W LED	SERENGA SMART FRAME 4 LED - CURVED FACE	70 mA	60 mA	0.9 KG
SER-FS2DS	2 x 1W LED (Side Wired)	SERENGA SMART FRAME 2 LED - CURVED FACE/ FLAG FORMAT	60 mA	30 mA	0.9 KG
SER-FS4DS	4 x 1W LED (Side Wired)	SERENGA SMART FRAME 4 LED - CURVED FACE/ FLAG FORMAT	70 mA	60 mA	0.9 KG

For testing and dimmable control assemblies, please contact Emergi-lite

Legends are screen printed. ISO 7010 format legends shown. Euro pictogram legends are available to order, please contact Emergi-Lite

Includes legend down-blank. Designed and manufactured to meet the requirements of BS EN 60598.2.22

Part No.	Legends
European signs directive, SI341 format	
SER-SC010	
SER-SC011	
SER-SC012	
SER-SC013	
ISO 7010 legend format	
SER-SCN10	
SER-SCN11	
SER-SCN12	
SER-SCN13	
Arabic legend format	
SER-SCB01	
Safety signs	
SER-SC802	
SER-SC803	

Accessories

Order code	Description
SER-BZKIT	RECESSING KIT
SER-RKIT150	TUBE SUSPENSION KIT (0.15 M)
SER-RKIT300	TUBE SUSPENSION KIT (0.3 M)
SER-RKIT500	TUBE SUSPENSION KIT (0.5 M)
SER-RKIT1000	TUBE SUSPENSION KIT (1 M)

For further information on Naveo and IR2 emergency luminaire testing formats, please contact Emergi-Lite

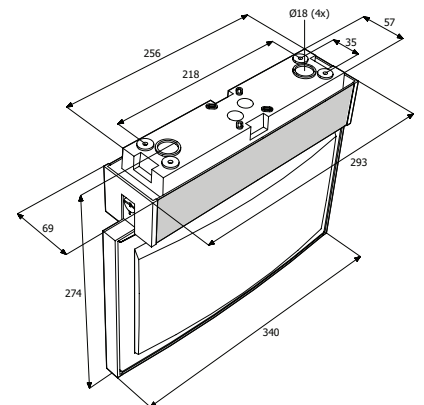

Serenga

Contemporary & economical



LED escape route illumination, back to wall mount, plastic frame, aluminium trim (FB model = CURVED on front face, back to wall)

- 2 surface mount orientations
- 2 LED exit sign or 4 LED exit sign with downlighters
- First-Fix mounting
- High grade polycarbonate body with aluminium trim



Control assembly

Order code	Input Voltage	Description	Operation / Duration (hrs)	Recharge Period	Environment Temperature	Weight
SER-M3-003	220 - 240 Vac, 50 Hz	SERENGA M3 CNTRL MODULE & BATT PACK, 50Hz	M3	24 hrs	5-25 °C	0.8 kg
CTSER-M3-003	220 - 240 Vac, 50 Hz	SERENGA M3 CNTRL MODULE & BATT PACK, CT VERSION, 50 Hz	M3	24 hrs	5-25 °C	0.8 kg
CTSER-M3EV2-003	220 - 240 Vac, 60 Hz	SERENGA M3 CNTRL MODULE & BATT PACK, CT VERSION, 60 Hz	M3	24 hrs	5-25 °C	0.8 kg
SER-M3EV2-003	220 - 240 Vac, 60 Hz	SERENGA M3 CNTRL MODULE & BATT PACK, 60Hz	M3	24 hrs	5-25 °C	0.8 kg
SER-230-003	85 - 240 Vac, 50 Hz	SERENGA CONTROL MODULE 230V MAINS	230 V	-	0-40 °C	0.8 kg
SER-230LTC-003	POWER CONSUMPTION VEAVE	SERENGA CONTROL MODULE 230V, LTC VERSION	230 V	-	0-40 °C	0.8 kg

Smart- Frame

Order code	Lamptype	Description	Power Consumption Self Contained	Power Consumption Slave	Weight
SER-FB2D	2 x 1W LED	SERENGA SMART FRAME 2 LED - WALL MOUNT/ CURVED	60 mA	30 mA	0.9 KG
SER-FB4D	4 x 1W LED	SERENGA SMART FRAME 4 LED - WALL MOUNT/ CURVED	70 mA	60 mA	0.9 KG

For testing and dimmable control assemblies, please contact Emergi-lite

Legends are screen printed. ISO 7010 format legends shown. Euro pictogram legends are available to order, please contact Emergi-Lite

Includes legend down-blank. Designed and manufactured to meet the requirements of BS EN 60598.2.22

Part No.	Legends
European signs directive, SI341 format	
SER-SC010	
SER-SC011	
SER-SC012	
SER-SC013	
ISO 7010 legend format	
SER-SCN10	
SER-SCN11	
SER-SCN12	
SER-SCN13	
Arabic legend format	
SER-SCB01	
Safety signs	
SER-SC802	
SER-SC803	

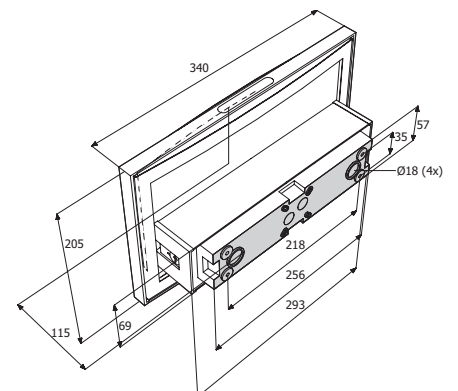

Endurance

Sleek, modular & contemporary



Edge-lit LED escape route exit luminaire with long life expectancy

- Low Power Consumption
- Available in standard white, black and silver options
- Wide range of mounting accessories
- High viewing distance up to 27 meter

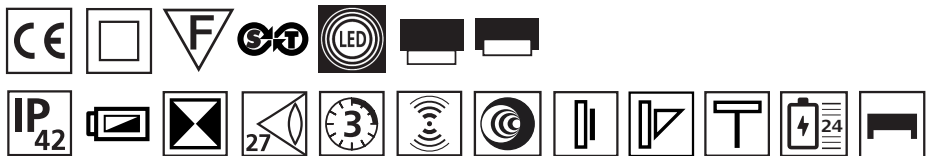

5

Luminaire

Order code	Input Voltage	Description	Lamp type	Power Consumption	Colour	Recharge Period	Operation / Duration (hrs)	Environment Temperature	Weight
ENV50-001	220-240V 50Hz	SLFTEST LED M3 WH IP20	LED strip, 1W	27 mA	Black	M3	24hrs	0-25 °C	1.4 kg
ENV30LTC-001	220-240V 50Hz	CCFL 230V50Hz LTC WH IP20	CCFL	40 mA	Silver	230 V	-	0-25 °C	1.4 kg
CTENV60-001	220-240V 50Hz	CT-N LED M3 WH IP20	LED	27 mA	White	M3	24hrs	0-25 °C	1.4 kg
EM3-001	220-240V 50Hz	ENDURANCE EXIT SIGN	CCFL	40 mA	White	M3	24hrs	0-25 °C	1.4 kg
EM3-002 *	220-240V 50Hz	ENDURANCE EXIT SIGN	CCFL	40 mA	Silver	M3	24hrs	0-25 °C	1.4 kg
EM3-003 *	220-240V 50Hz	ENDURANCE EXIT SIGN	CCFL	40 mA	Silver	M3	24hrs	0-25 °C	1.4 kg

* Fluorescent = NiCD, LED = NiMH. Black & silver options available to order
 Please contact Emergi-Lite. For AC/AC or AC/DC slave units please refer to our EMEX Central Power Supply Systems Catalogue
 Designed and manufactured to meet the requirements of BS EN 60598.2.22
 Kitemark approved product.

Single sided

Part No.	Legends
European signs directive, SI341 format	
ESS012	
ESS010	
ESS011	
ESS013	
ISO 7010 legend format	
ESSN12	
ESSN10	
ESSN11	
ESSN13	
Arabic legend format	
On request	

Double sided

Part No.	Legends
European signs directive, SI341 format	
EDS020	
EDS021	
EDS022	
ISO 7010 legend format	
EDSN20	
EDSN21	
EDSN22	
Arabic legend format	
On request	

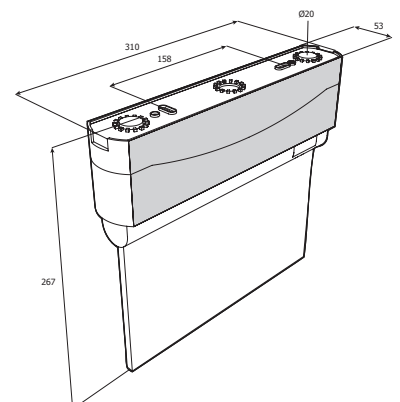

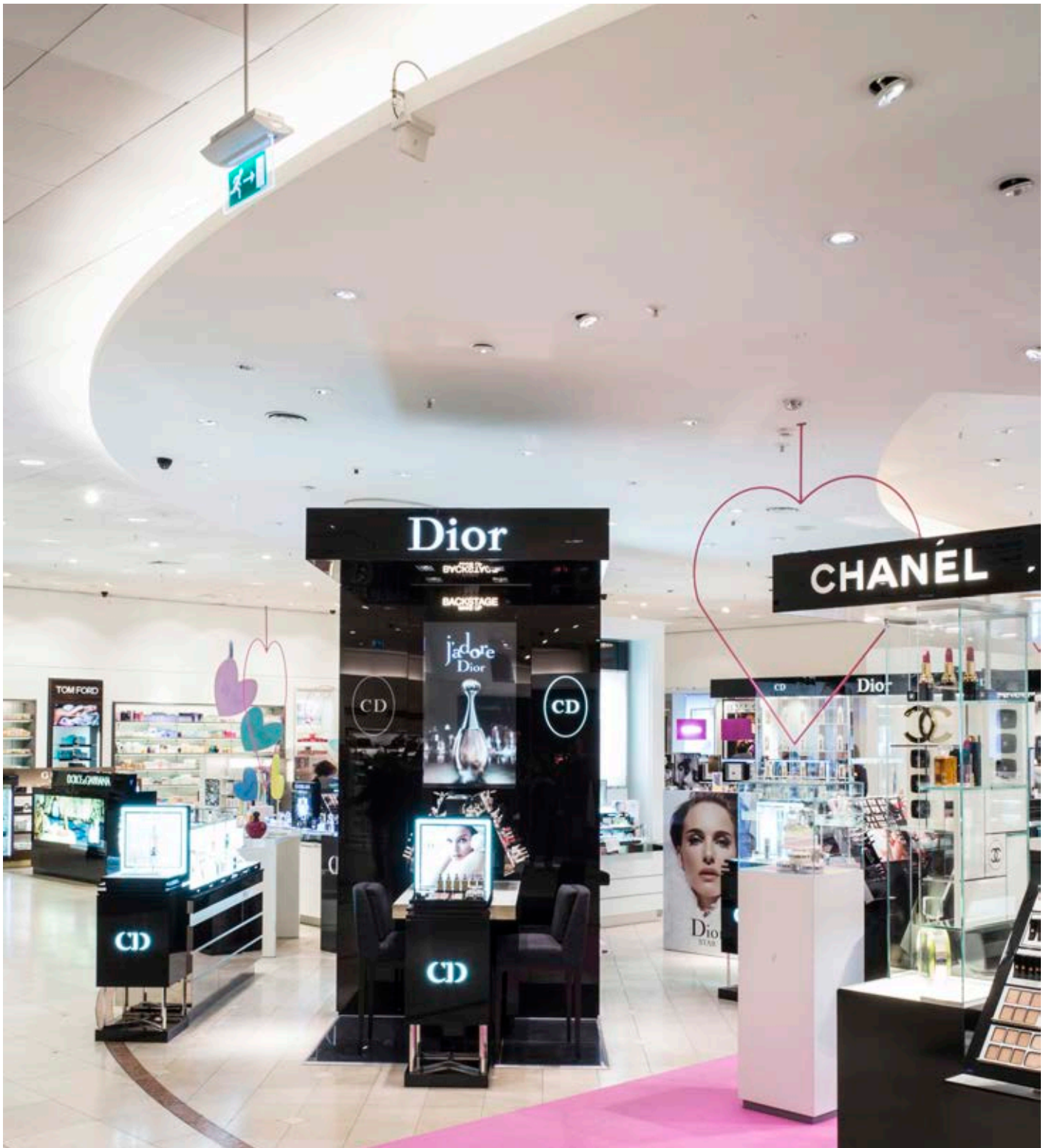

Horizon Traditional & versatile

- Clip on legend with frame
- Shaped diffuser and contoured reflector
- First-Fix aluminium base, polycarbonate body
- Available for surface and recessed mounting

Horizon Traditional & versatile



LED back-lit exit sign

- Clip on legend panel
- Shaped diffuser and contoured reflector
- First-Fix aluminium base with white polycarbonat luminaire body
- Available in surface and recessed

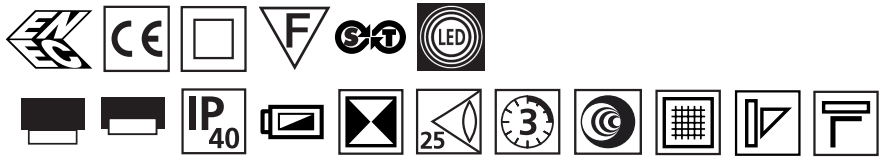

Luminaire

6

Order code	Input Voltage	Description	Lamp type	Power Consumption	Operation / Duration (hrs)	Recharge Period	Environment Temperature	Weight
OH3L261	220 - 240 Vac, 50 Hz	SLFTEST LED X2 M3 ALU SLVER IP20	2 x 1WLED	60mA	M3	24 hrs	0-25 °C	1.7 kg
OH3L261V2	220 - 240 Vac, 60 Hz	SLFTEST LED X2 M3 ALU SLVER IP20	2 x 1WLED	60mA	M3	24 hrs	0-25 °C	1.7 kg
OH1L261HF	220 - 240 Vac, 50/60 Hz	LED X2 230V50Hz ALU SLVER IP20	2 x 1WLED	20mA	230 V	-	0-40 °C	1.5 kg
OZ3L261	220 - 240 Vac, 50 Hz	SLFTEST LED X2 M3 ALU SLVER IP20	2 x 1WLED	60mA	M3	24 hrs	0-25 °C	1.7 kg
OZ1L261HF	220 - 240 Vac, 50/60 Hz	LED X2 230V50Hz ALU SLVER IP20	2 x 1WLED	30mA	230 V	-	0-40 °C	1.5 kg
OH1L261LTC	321 - 240 Vac, 50/60 Hz	LED X2 230V50Hz LTC ALU SLVER IP20	2 x 1WLED	30 mA	230 V	-	0-40 °C	1.5 kg
OZ1L261LTC	322 - 240 Vac, 50/60 Hz	LED X2 230V50Hz LTC ALU SLVER IP20	2 x 1WLED	30 mA	230 V	-	0-40 °C	1.5 kg
CTOH3L261	220 - 240 Vac, 50 Hz	CT-N LED X2 M3 ALU SLVER IP20	2 x 1WLED	30 mA	M3	24 hrs	0-25 °C	1.7 kg

Legends are screen printed. ISO 7010 format legends shown. Euro pictogram legends are available to order, please contact Emergi-Lite
Designed and manufactured to meet the requirements of BS EN 60598.2.22

Part No.	Legends
European signs directive, SI341 format	
XE02H	
XE03H	
XE06H	
XE05H	
ISO 7010 legend format	
XEN2H	
XEN3H	
XEN6H	
XEN5H	
Arabic legend format	
XB01H	
Safety signs	
XLF802H	
XLF803H	



Accessories

Order code	Description
OH/BCM	OH/BCM CEILING BRACKET
OH/WG	OH/WG PROTECTIVE WIRE GUARD
OH/BWM	OH/BCM SIDE WALL BRACKET

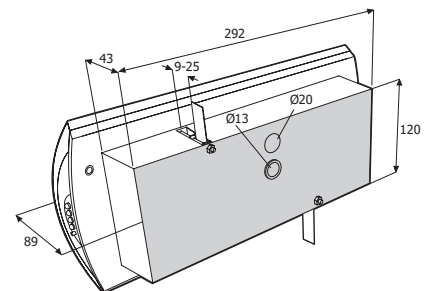
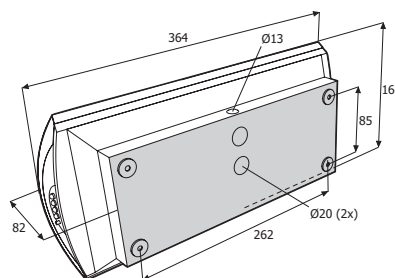

Horizon

Traditional & versatile



LED edge-lit exit sign

- Legend panel with slotted aluminium frame - single or double sided legend
- Shaped diffuser and contoured reflector
- First-Fix aluminium base with white polycarbonat luminaire body
- Available in surface and recessed



Luminaire

Order code	Input Voltage	Description	Lamp type	Power Consumption	Operation / Duration (hrs)	Recharge Period	Environment Temperature	Weight
OHD3LS61	220-240V50Hz	SLFTEST LED STRIP M3 ALU SLVER IP20	2 x 1WLED	60 mA	M3	24 hrs	0-25 °C	1.7 kg
OHD1LS61HF	220-240V50Hz	LED STRIP 230V50Hz ALU SLVER IP20	2 x 1WLED	30 mA	230 V	-	0-40 °C	1.5 kg
OZD3LS61	220-240V50Hz	SLFTEST LED STRIP M3 ALU SLVER IP20	2 x 1WLED	60 mA	M3	24 hrs	0-25 °C	1.7 kg
OZD3LS61V2	220-240V60Hz	SLFTEST LED STRIP M3 ALU SLVER IP20	2 x 1WLED	60 mA	M3	24 hrs	0-25 °C	1.7 kg
OZD1LS61HF	220-240V50Hz	LED STRIP 230V50Hz ALU SLVER IP20	2 x 1WLED	30 mA	230 V	-	0-40 °C	1.5 kg
OHD1LS61LTC	220-240V50Hz	LED STRIP 230V50Hz LTC ALU SLVER IP20	2 x 1WLED	30 mA	230 V	-	0-40 °C	1.5 kg
OZD1LS61LTC	220-240V50Hz	LED STRIP 230V50Hz LTC ALU SLVER IP20	2 x 1WLED	30 mA	230 V	-	0-40 °C	1.5 kg
CTOHD3LS61	220-240V50Hz	CT-N LED STRIP M3 ALU SLVER IP20	2 x 1WLED	-	M3	24 hrs	0-25 °C	1.5 kg
CTOZD3LS61	220-240V50Hz	CT-N LED STRIP M3 ALU SLVER IP20	2 x 1WLED	-	M3	24 hrs	0-25 °C	1.7 kg

Legends are screen printed. ISO 7010 format legends shown. Euro pictogram legends are available to order, please contact Emergi-Lite
Designed and manufactured to meet the requirements of BS EN 60598.2.22

Single sided

Part No.	Legends
European signs directive, SI341 format	
XE20HS	
XE30HS	
XE60HS	
XE50HS	
ISO 7010 legend format	
XEN20HS	
XEN30HS	
XEN60HS	
XEN50HS	
Arabic legend format	
XB01H	
Safety signs	
XLF802H	
XLF803H	

Double sided

Part No.	Legends
European signs directive, SI341 format	
XE22HD	
XE36HD	
ISO 7010 legend format	
XEN22HD	
XEN36HD	
XEN55HD	
Arabic legend format	
XB01HD	

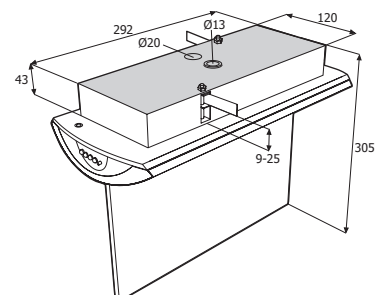
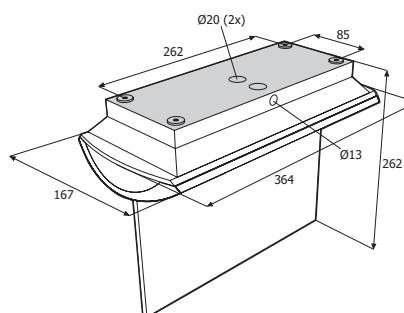

Accessories

Order code	Description
OH/BWM	OH/BCM SIDE WALL BRACKET
OH/BCM	MOUNTING KIT WH CEILING, BACK FIT

Horizon

Traditional & versatile



Escape route signalisation - Combined with lighting

- Legend panel with open aluminium frame - single or double sided legend
- Shaped diffuser and contoured reflector
- First-Fix aluminium base with white polycarbonate luminaire body
- Available in surface and recessed

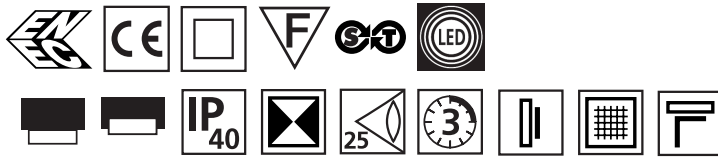

Luminaire

6

Order code	Input Voltage	Description	Lamp Output	Lamp type	Power Consumption	Operation / Duration (hrs)	Recharge Period	Environment Temperature	Weight
OH23161	220 - 240 Vac, 50/60 Hz	SLFTEST LED STRIP M3 ALU SLVER IP20	156 lumens	8 W T5	20 mA	NM3	24 hrs	0-25 °C	1.5 kg
OH33161	220 - 240 Vac, 50/60 Hz	LED STRIP 230V50Hz ALU SLVER IP20	156 lumens	8 W T5	70 mA	M3	24 hrs	0-25 °C	1.7 kg
OH13161HF	220 - 240 Vac, 50/60 Hz	SLFTEST LED STRIP M3 ALU SLVER IP20	253 lumens	8 W T5	70 mA	230 V	-	0-25 °C	-
OH13161LTC	220 - 240 Vac, 50/60 Hz	SLFTEST LED STRIP M3 ALU SLVER IP20	253 lumens	8 W T5	70 mA	230 V	-	0-25 °C	-
OZ23161	220 - 240 Vac, 50 Hz	LED STRIP 230V50Hz ALU SLVER IP20	253 lumens	8 W T5	20 mA	NM3	24 hrs	0-25 °C	-
OZ33161	220 - 240 Vac, 50 Hz	LED STRIP 230V50Hz LTC ALU SLVER IP20	253 lumens	8 W T5	70 mA	M3	24 hrs	0-25 °C	-
OZ13161HF	220 - 240 Vac, 50/60 Hz	LED STRIP 230V50Hz LTC ALU SLVER IP20	253 lumens	8 W T5	70 mA	230 V	-	0-25 °C	-
OZ13161LTC	220 - 240 Vac, 50/60 Hz	CT-N LED X2 M3 ALU SLVER IP20	253 lumens	8 W T5	70 mA	230 V	-	0-25 °C	-

Designed and manufactured to meet the requirements of BS EN 60598.2.22

Single sided

Part No.	Legends
European signs directive, SI341 format	
XE20HS	
XE30HS	
XE60HS	
XE50HS	
ISO 7010 legend format	
XEN20HS	
XEN30HS	
XEN60HS	
XEN50HS	
Arabic legend format	
XB01H	
Safety signs	
XLF802H	
XLF803H	

Double sided

Part No.	Legends
European signs directive, SI341 format	
XE22HD	
XE36HD	
ISO 7010 legend format	
XEN22HD	
XEN36HD	
XEN55HD	
Arabic legend format	
XB01HD	

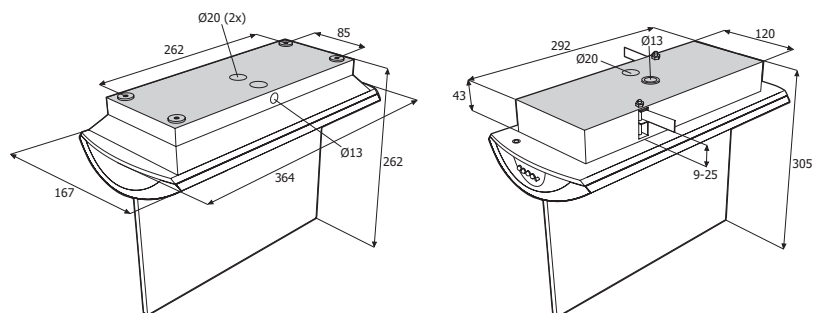
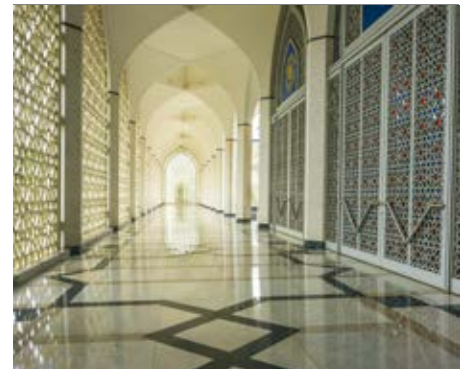

Accessories

Order code	Description
OH/BWM	WALL BRACKET FOR EDGE-LIT SIGN/LUMINAIRE
OH/WG	PROTECTIVE WIRE GUARD
OH/BCM	MOUNTING KIT WH CEILING, BACK FIT

Corniche

Classical and timeless



Luminaire

Distinctive edge-lit exit sign

- Suitable for both prestigious, period settings and contemporary decors
- Mains connector block seated in support pod
- Includes chain for maximum of 0.5 m suspension
- Available in white, polished brass or stainless steel trim

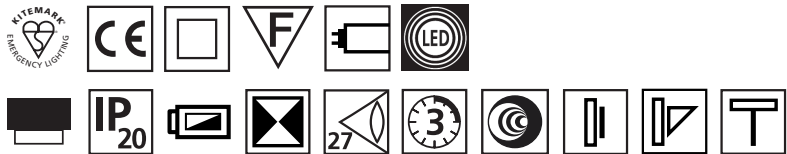

Order code	Input Voltage	Description	Lamp type	Power Consumption	Operation / Duration (hrs)	Environment Temperature	Weight
NB331*	220-240V 50/60Hz	EDGE LIT 8W M3	8W T5	M3	24 hrs	0-40 °C	2.5 - 3.1 kg
NB3LS*	220-240V 50/60Hz	EDGE LIT LED M3	LED	M3	24 hrs	0-40 °C	2.5 - 3.1 kg
CTNB331*	220-240V 50/60Hz	EDGE LIT 8W CTM3	8W T5	M3	24 hrs	0-40 °C	2.5 - 3.1 kg
NB131*HF	220-240V 50/60Hz	EDGE LIT 8W 230HF	8W T5	230 V	-	0-40 °C	2.5 - 3.1 kg
NB131*LTC	220-240V 50/60Hz	EDGE LIT 8W 230LTC	8W T5	230 V	-	0-40 °C	2.5 - 3.1 kg
NB1LS*HF	220-240V 50/60Hz	EDGE LIT LED 230HF	LED	230 V	-	0-40 °C	2.5 - 3.1 kg
NB1LS*LTC	220-240V 50/60Hz	EDGE LIT LED 230LTC	LED	230 V	-	0-40 °C	2.5 - 3.1 kg

Add *=1, White Trim, =4 Brass Trim, =5 Stainless Steel Trim (Ordering example: NB3LS1 reflects Corniche LED, M3 hrs Duration, White Trim)

Legends are screen printed. ISO 7010 format legends shown. Euro pictogram legends are available to order, please contact Emergi-Lite

Designed and manufactured to meet the requirements of BS EN 60598.2.22

Single sided

Part No.	Legends
European signs directive, S1341 format	
XE02NT31	
XE03NT31	
XE06NT31	
XE05NT31	
ISO 7010 legend format	
XEN2NT31	
XEN3NT31	
XEN6NT31	
XEN5NT31	
Arabic legend format	
XB01NT31	

Double sided

Part No.	Legends
European signs directive, S1341 format	
XE03/6NT32	
ISO 7010 legend format	
XEN3/6NT32	
Arabic legend format	
XB01NT32	



Accessories

Order code	Description	Colour
NB/BFM07	CANTILIER WALL BRACKET	
NB/BWM07	BACK TO WALL BRACKET	

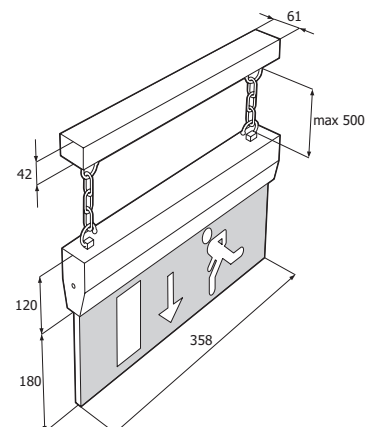

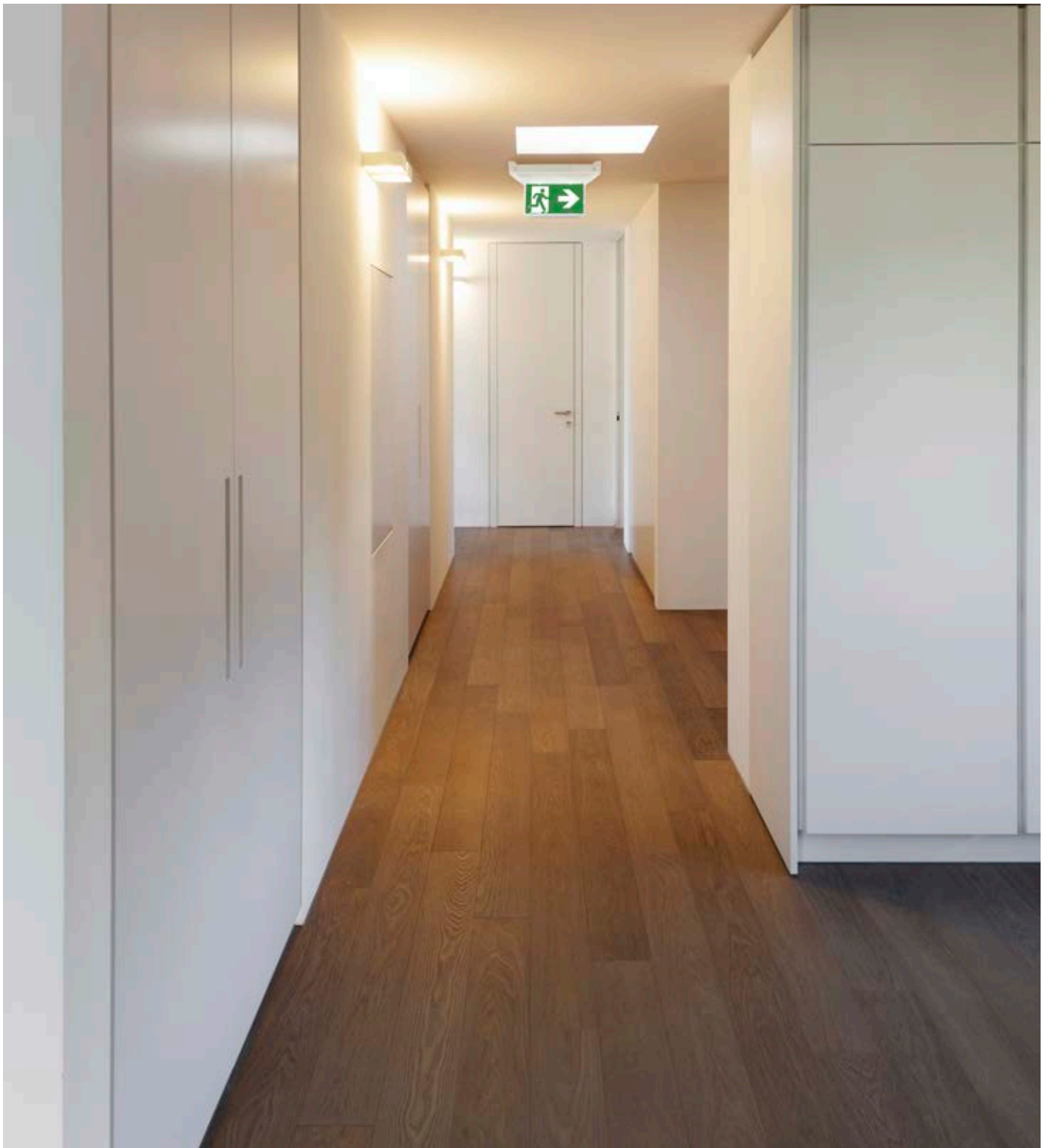

8

PreviX Quick & practical

- Quality in its simplicity
- Lighting and signalisation in one, depending on the model
- Installation within three minutes

Previx

Quick & practical



Luminaire

Back-lit / Edge-lit LED luminaire

- High grade polycarbonate body
- Straightforward installation, with First-Fix base
- Flexible mounting options
- Economical and durable



Order code	Input Voltage	Description	Lamptype	Power Consumption	Operation / Duration (hrs)	Recharge Period	Environment Temperature	Weight
PX3LS1	220 - 240 Vac, 50 Hz	LED M-NM3 WH IP20	1 W LED strip	27 mA	M3	24 hrs	0-25 °C	1.0 kg
PX1LS1HF	220 - 240 Vac, 50/60 Hz	LED 230V50HZ WH IP20	1 W LED strip	30 mA	230 V	-	0-40 °C	0.9 kg
PX1LS1LTC	220 - 240 Vac, 50/60 Hz	LED 230V50HZ LTC WH IP20	1 W LED strip	30 mA	230 V	-	0-40 °C	1.0 kg
CTPX3LS1	220 - 240 Vac, 50 Hz	CT-N LED STRIP M3 WH IP20	1 W LED strip	27 mA	M3	24 hrs	0 - 25 °C	1.0 kg

Legends are screen printed. ISO 7010 format legends shown. Euro pictogram legends are available to order, please contact Emergi-Lite
Designed and manufactured to meet the requirements of BS EN 60598.2.22

Part No.	Legends
European signs directive, SI341 format	
XE02PX	
XE03PX	
XE06PX	
XE05PX	
ISO 7010 legend format	
XEN2PX	
XEN3PX	
XEN6PX	
XEN5PX	
Arabic legend format	
On request	

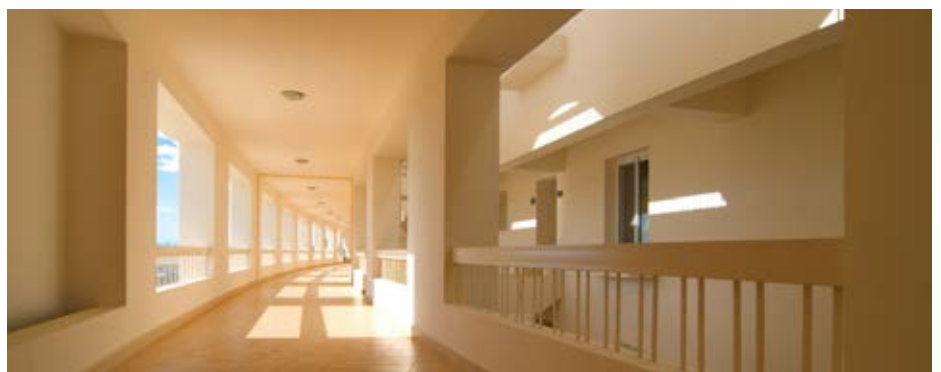

Accessories

Order code	Description
BK XL	PROTECTIVE WIRE GUARD
PX/BCM	CEILING BRACKET, VERTICAL MOUNT
PX/BWM	WALL BRACKET, FOR FLAG SIGN MOUNT
PX/LENS4	SET OF 4 LENSES (FOR ENHANCED SPACING IN GENERAL USE)
PX/DSLKIT	DOUBLE SIDED EXIT SIGN KIT

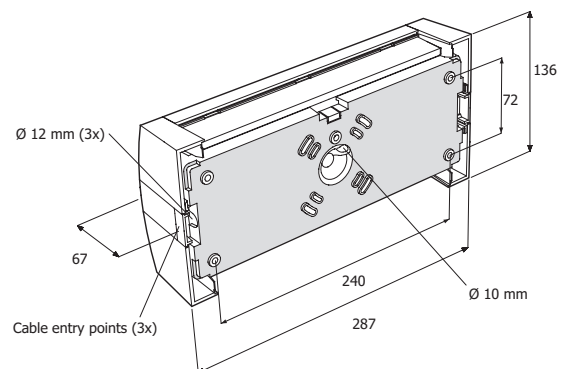

Previx

Quick & practical



Edge-lit LED exit sign

- High grade polycarbonate body
- Straight forward installation, with First-Fix Base
- Economical and durable

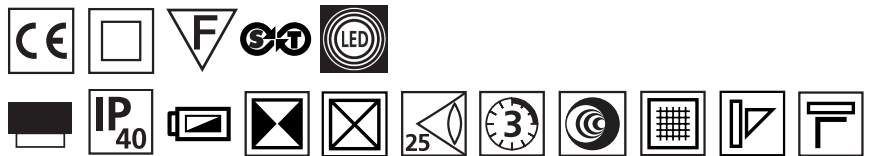

Luminaire

Order code	Input Voltage	Description	Lamptype	Power Consumption	Operation / Duration (hrs)	Recharge Period	Environment Temperature	Weight
PX3LS1	220 - 240 Vac, 50 Hz	LED M-NM3 WH IP20	1 W LED strip	27 mA	M3	24 hrs	0-25 °C	1.0 kg
PXR3LS1	220 - 240 Vac, 50 Hz	LED M-NM3 WH IP20	1 W LED strip	27 mA	M3	24 hrs	0-40 °C	1.4 kg
PX1LS1HF	220 - 240 Vac, 50/60 Hz	LED 230V50HZ WH IP20	1 W LED strip	30 mA	230 V	-	0-40 °C	0.9 kg
PX1LS1LTC	220 - 240 Vac, 50/60 Hz	LED 230V50HZ LTC WH IP20	1 W LED strip	30 mA	230 V	-	0-40 °C	1.3 kg
PXR1LS1HF	220 - 240 Vac, 50/60 Hz	LED 230V50HZ WH IP20	1 W LED strip	30 mA	230 V	-	0-40 °C	0.9 kg
PXR1IS1LTC	220 - 240 Vac, 50 Hz	LED 230V50HZ LTC WH IP20	1 W LED strip	27 mA	M3	24 hrs	0-40 °C	1.3kg

Legends are screen printed. ISO 7010 format legends shown. Euro pictogram legends are available to order, please contact Emergi-Lite
Designed and manufactured to meet the requirements of BS EN 60598.2.22

Part No.	Legends
European signs directive, SI341 format	
XE02PX	
XE03PX	
XE06PX	
XE05PX	
ISO 7010 legend format	
XEN2PX	
XEN3PX	
XEN6PX	
XEN5PX	
Arabic legend format	
On request	



Accessories

Order code	Description
PX/DSLKIT	DOUBLE SIDED EXIT SIGN KIT

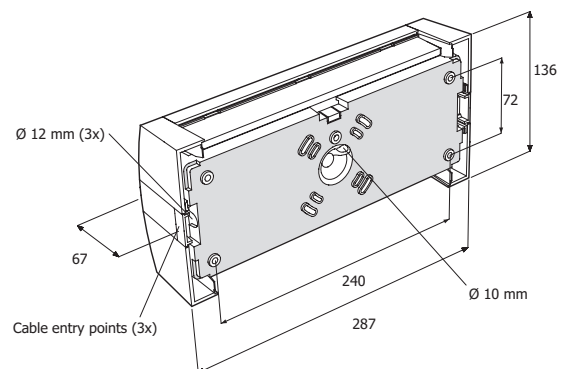

Previx Quick & practical



Recessed LED luminaire

- High grade polycarbonate body
- Straightforward installation, with first - fix base
- Economical and durable
- Increased spacing achieved with optional lens kit (PX/LENS4)

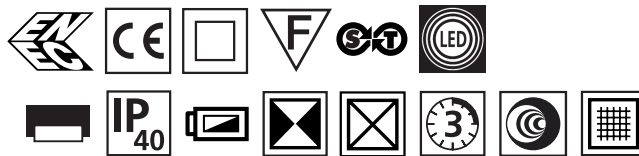

Luminaire

Order code	Input Voltage	Description	Lamp type	Lamp Output	Power Consumption	Operation / Duration (hrs)	Recharge Period	Environment Temperature	Weight
PXR3LS1	220 - 240 Vac, 50 Hz	LED M-NM3 WH IP20	1 W LED strip	147 lm	27 mA	M3	24 hrs	0-25 °C	1.4 kg
PXR1LS1HF	220 - 240 Vac, 50/60 Hz	LED 230V50HZ WH IP20	1 W LED strip	185 lm	30 mA	230 V	-	0-40 °C	0.9 kg
PXR1LS1LTC	220 - 240 Vac, 50/60 Hz	LED 230V50HZ LTC WH IP20	1 W LED strip	185 lm	30 mA	230 V	-	0-40 °C	1.3 kg
CTPXR3LS1	220 - 240 Vac, 50 Hz	CT-N LED STRIP M3 WH IP20	1 W LED strip	147 lm	27 mA	M3	24 hrs	0-25 °C	1.4 kg

Legends are screen printed. ISO 7010 format legends shown. Euro pictogram legends are available to order, please contact Emergi-Lite
Designed and manufactured to meet the requirements of BS EN 60598.2.22

Part No.	Legends
European signs directive, SI341 format	
XE02PX	
XE03PX	
XE06PX	
XE05PX	
ISO 7010 legend format	
XEN2PX	
XEN3PX	
XEN6PX	
XEN5PX	
Arabic legend format	
On request	



Accessories

Order code	Description
BK XL	PROTECTIVE WIRE GUARD
PX/LENS4	SET OF 4 LENSES (FOR ENHANCED SPACING IN GENERAL USE)
DSLKIT	DOUBLE SIDED EXIT SIGN KIT

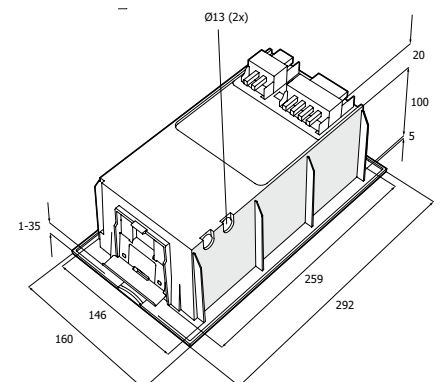

Silver-lite

Robust and durable



Luminaire

Edge-lit LED/FL exit sign

- Ideal for modern commercial environments
- Available with stainless steel, brushed silver aluminium, white or mirror finish brass trim plate
- Heavy duty steel enclosure with wing fixings for recessed application with separate slotted metal trim plate to support legend
- Order recessed unit, trim plate and legend separately

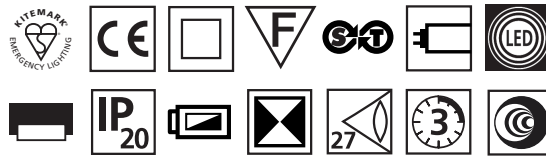

Order code	Input Voltage	Description	Lamptype	Operation / Duration (hrs)	Recharge Period	Environment Temperature	Weight
AR3LS	220-240V50/60Hz	LED M3 IP20	1W LED	M3	24 hrs	0-25 °C	2.0 kg
ARV33	220-240V50/60Hz	8WT5 M3 IP20	8W T5	M3	24 hrs	0-25 °C	2.0 kg
AR13LTC	220-240V50/60Hz	230V50HZ LTC IP20	8W T5	230 V	-	0-25 °C	2.0 kg
AR13HF	220-240V50/60Hz	230V50HZ HF IP20	8W T5	230 V	-	0-25 °C	2.0 kg
AR1LSHF	220-240V50/60Hz	LED 110-230V IP20	1W LED	230 V	-	0-25 °C	2.0 kg
AR1LSLTC	220-240V50/60Hz	LED 230V50HZ LTC IP20	1W LED	230 V	-	0-25 °C	2.0 kg
CTAR33111	220-240V50/60Hz	CT-N 8WT5 M3 WH	8W T5	230 V	-	0-25 °C	2.0 kg
CTAE3311	220-240V50/60Hz	CT-N 8WT5 M3 WH	8W T5	M3	24 hrs	0-25 °C	2.0 kg
CTAE3314	220-240V50/60Hz	CT-N 8WT5 M3 BRASS	8W T5	230 V	-	0-25 °C	2.0 kg

Legends are screen printed. ISO 7010 format legends shown. Euro pictogram legends are available to order, please contact Emergi-Lite
Designed and manufactured to meet the requirements of BS EN 60598.2.22

Single sided

Part No.	Legends
European signs directive, SI341 format	
XE02A31	
XE03A31	
XE06A31	
XE05A31	
ISO 7010 legend format	
XEN2A31	
XEN3A31	
XEN6A31	
XEN5A31	
Arabic legend format	
XB01A31	

Double sided

Part No.	Legends
European signs directive, SI341 format	
XE03/6A32	
ISO 7010 legend format	
XEN36A32	
Arabic legend format	
On request	

Accessories

Order code	Description	Colour
AE01	WHITE SLOTTED TRIM	
AE04	BRASS SLOTTED TRIM	
AE05	S/STEEL SLOTTED TRIM	
AE06	BRUSHED ALU SLOTTED TRIM	

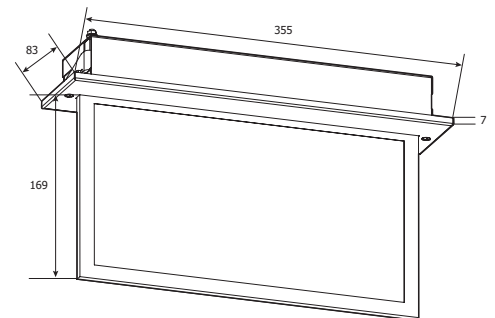

Silver-lite

Robust and durable



Edge-lit LED/FL emergency luminaire

- Ideal for modern commercial environments
- Available with stainless steel, brushed silver aluminium, white or mirror finish brass trim plate
- Heavy duty steel enclosure with wing fixings for recessed application with separate slotted metal trim plate to support legend
- Order recessed unit, trim plate and legend separately

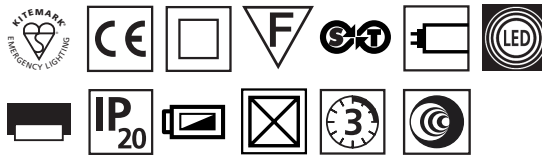

Luminaire

Order code	Input Voltage	Description	Lamp type	Lamp Output	Operation / Duration (hrs)	Recharge Period	Environment Temperature	Weight
AR2LS	220-240V50/60Hz	LED NM3 IP20	1W LED	90 lm	NM3	24 hrs	0-25 °C	1.8 kg
ARV23	220-240V50/60Hz	FL NM3 IP20	8W T5	100 lm	NM3	24 hrs	0-25 °C	1.8 kg
AR13HF	220-240V50/60Hz	FL 230V50HZ HF IP20	8W T5	300 lm	230 V	-	0-25 °C	1.8 kg
AR1LSHF	220-240V50/60Hz	LED 110-230V IP20	1W LED	90 lm	230 V	-	0-25 °C	1.8 kg
AR13LTC	220-240V50/60Hz	FL 230V50HZ LTC IP20	8W T5	300 lm	230 V	-	0-25 °C	1.8 kg
AR1LSLTC	220-240V50/60Hz	LED 230V50HZ LTC IP20	1W LED	90 lm	230 V	-	0-25 °C	1.8 kg
CTAR23111	220-240V50/60HZ	CT-N 8WT5 NM3 WH	8W T5	100 lm	NM3	24 hrs	0-25 °C	1.8 kg

Designed and manufactured to meet the requirements of BS EN 60598.2.22

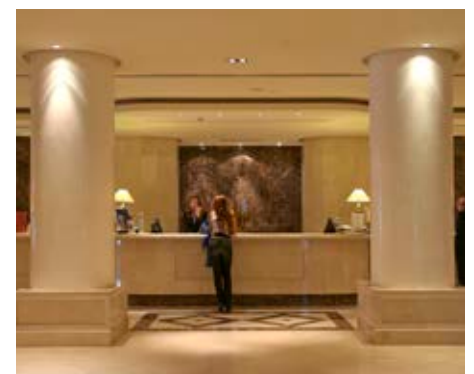

Accessories

Order code	Description	Colour
AR011	WHITE TRIM	
AR041	BRASS TRIM	
AR051	STAINLESS STEEL TRIM	
AR061	BRUSHED ALUMINIUM	

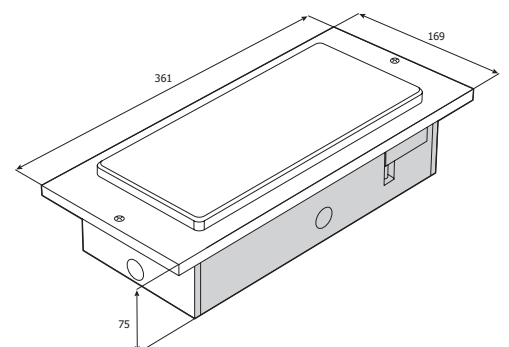

Navigator per forma

Practical & everyday



Escape route signalisation

- Generous downlight panel provides additional illumination at floor level
- Available in white trim, gold effect trim, stainless steel trim
- Ideal for wall mounting above doorways
- Suitable for public buildings, offices, retail etc.

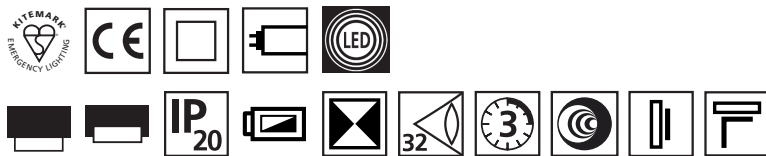

Luminaire

Order code	Input Voltage	Description	Lamp type	Power Consumption	Operation / Duration (hrs)	Recharge Period	Environment Temperature	Weight
VE331*	220-240Vac, 50/60 Hz	8WT5 M3 WH IP20	8W T5	60 mA	M3	24 hrs	0-25 °C	2.2 kg
VE3LS*	220-240Vac, 50/60 Hz	LED M3 WH IP20	1W LED	27mA	M3	24 hrs	0-25 °C	2.2 kg
VE131*HF	220-240Vac, 50/60 Hz	230V50HZ HF WH	8W T5	-	230 V	-	0-25 °C	2.2 kg
VE131*LTC	220-240Vac, 50/60 Hz	230V50HZ LTC WH	8W T5	-	230 V	-	0-25 °C	2.2 kg
VE1LS*HF	220-240Vac, 50/60 Hz	LED 110-230V WH IP20	1W LED	-	230 V	-	0-25 °C	2.2 kg
VE1LS*LTC	220-240Vac, 50/60 Hz	LED 230V50HZ LTC WH IP20	1W LED	-	230 V	-	0-25 °C	2.2 kg

Add *=1 White Trim, =7 Gold effect trim, =5 Stainless Steel trim (Ordering Example, VE3LS1 reflects Navigator Compact LED, M3 hrsDuration, White Trim)
Designed and manufactured to meet the requirements of BS EN 60598.2.22

10

Part No.	Legends
European signs directive, SI341 format	
XE02V31	
XE03V31	
XE06V31	
XE05V31	
ISO 7010 legend format	
XEN2V31	
XEN3V31	
XEN6V31	
XEN5V31	
Arabic legend format	
XB01V31	



Accessories

Order code	Description
VEBACK	REAR TRIM PLATE IN WHITE FOR A FLAT BACK WHEN REQUIRED FOR CEILING MOUNTING

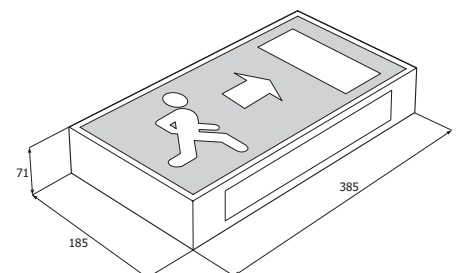

Navigator compact

Practical & everyday



Escape route signalisation

- Generous downlight panel provides additional illumination at floor level
- Ideal for wall mounting above doorways
- Large, highly visible sign
- Suitable for auditoria, hotel foyers, corridors etc.

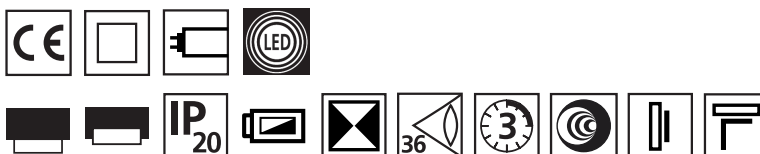

Luminaire

Order code	Input Voltage	Description	Lamptype	Power Consumption	Operation / Duration (hrs)	Recharge Period	Environment Temperature	Weight
EE3311	220-240Vac, 50/60 Hz	8WT5 M3 WH IP20	8W T5	60 mA	M3	24 hrs	0-25 °C	3.0 kg
EE4321	220-240Vac, 50/60 Hz	8WT5 X2 CNM3 WH IP20	2 x 8W T5	60 mA	CNM3	24 hrs	0-25 °C	3.2 kg
CTE3311	220-240Vac, 50/60 Hz	CT-N 8WT5 M3 WH	8W T5	-	M3	24 hrs	0-25 °C	3.0 kg
E1311HF	220-240Vac, 50/60 Hz	8WT5 230V50HZ HF WH	8W T5	-	SLAVE 230 V	-	0-25 °C	2.2 kg
E1311LTC	220-240Vac, 50/60 Hz	8WT5 230V50HZ LTC	1W LED	-	SLAVE 230 V	-	0-25 °C	2.2 kg

Designed and manufactured to meet the requirements of BS EN 60598.2.22

Part No.	Legends
European signs directive, SI341 format	
XE02E31	
XE03E31	
XE06E31	
XE05E31	
ISO 7010 legend format	
XEN2E31	
XEN3E31	
XEN6E31	
XEN5E31	
Arabic legend format	
XB01E31	

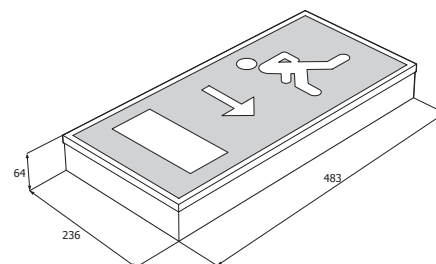

Weatherforce

Practical & robust



Escape route signalisation

- High grade polycarbonate enclosure with fixed legends
- Semi-recessing accessory available
- Suitable for public walkways, enclosed car parks etc
- Includes legends



Luminaire

Order code	Input Voltage	Description	Lamp type	Operation / Duration (hrs)	Environment Temperature	Weight
DV3LS1XE*	220-240Vac, 50/60Hz	SIGN DS LED M3 WH IP65	1W LED strip	M3	0-25 °C	2,1 kg
DV3311XE*	220-240Vac, 50/60Hz	SIGN DS 8WT5 M3 WH IP65	8W T5	M3	0-25 °C	2,1 kg
DB1311HFXE*	220-240Vac, 50/60Hz	SIGN DS 8WT5 230V WH IP65	8W T5	230 V	0-25 °C	2,1 kg
DB1311LTCXE*	220-240Vac, 50/60Hz	SIGN DS 8WT5 230V LTC WH IP65	8W T5	230 V	0-25 °C	2,1 kg
DWA1311LTCXE*	220-240Vac, 50/60Hz	SIGN DS 8WT5 230V LTC WH ALU IP65	8W T5	230 V	0-25 °C	2,1 kg
CTDB3LS1XE*	220-240Vac, 50/60Hz	SIGN DS CT-N LED M3 WH IP65	1W LED strip	M3	0-25 °C	2,1 kg
CTDB3311XE*	220-240Vac, 50/60Hz	SIGN DS CT-N 8WT5 M3 WH IP65	8W T5	M3	0-25 °C	2,1 kg

Designed and manufactured to meet the requirements of BS EN 60598.2.22

Double sided

Part No.	Legends
* Standard legend options	
XE36	
European signs directive, SI341 format	
XE22	
Arabic legend format	
RSB23DV	



Accessories

Order code	Description	Colour
BBZ	SEMI-RECESSING BEZEL KIT	

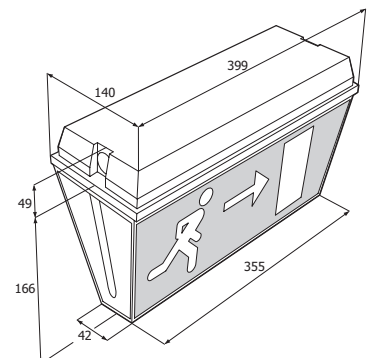

Weatherforce

Practical & robust



Escape route lighting

- Simple vandal resistant design
- Available with high grade polycarbonate (B) or cast aluminium (WA) enclosure
- Opal diffuser as standard with clear polycarbonate
- Converts easily to exit sign with addition of self adhesive legend

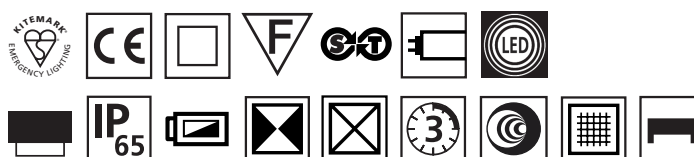

Luminaire

Order code	Input Voltage	Description	Lamp type	Lamp Output	Operation / Duration (hrs)	Environment Temperature	Weight
B2LS1	220-240Vac 50/60Hz	LED NM3 WH IP65	1W LED strip	90 lm	NM3	0-25 °C	1,7 kg
B3LS1	220-240Vac 50/60Hz	LED M3 WH IP65	1W LED strip	90 lm	M3	0-25 °C	2,1 kg
B2311*	220-240Vac 50/60Hz	FL NM3 WH IP65	8W T5	170 lm	NM3	0-25 °C	1,7 kg
B3311*	220-240Vac 50/60Hz	FL M3 WH IP65	8W T5	170 lm	M3	0-25 °C	1,9 kg
B4321*	220-240Vac 50/60Hz	FL CNM3 WH IP65	2 x 8W T5	170 lm	CNM3	0-25 °C	2,0 kg
WA2321	220-240Vac 50/60Hz	FL 2X8 NM3 WH IP65	2 x 8W T5	250 lm	NM3	0-25 °C	2,1 kg
B1311*HF	220-240Vac 50/60Hz	FL 8W230V IP65	8W T5	300 lm	230 V	0-25 °C	-
B1311*LTC	220-240Vac 50/60Hz	FL 8W230LTC IP65	8W T5	300 lm	230 V	0-25 °C	-
B1LS1HF	220-240Vac 50/60Hz	LED 8W230V IP65	1W LED strip	90 lm	230 V	0-25 °C	-
B1LS1LTC	220-240Vac 50/60Hz	LED 8W230LTC IP65	1W LED strip	90 lm	230 V	0-25 °C	-
CTB2311*	220-240Vac 50/60Hz	FL CT-N NM3 WH IP65	8W T5	170 lm	NM3	0-25 °C	-
CTB2LS1	220-240Vac 50/60Hz	LED CT-N NM3 WH IP65	1W LED strip	90 lm	NM3	0-25 °C	-
CTB3311*	220-240Vac 50/60Hz	FL CT-N M3 WH IP65	8W T5	170 lm	M3	0-25 °C	-
CTB3LS1	220-240Vac 50/60Hz	LED CT-N M3 WH IP65	1W LED strip	90 lm	M3	0-25 °C	-

* STANDARD-OPAL DIFFUSER. SUFFIX 1- CLEAR PRISMATIC DIFFUSER. Designed and manufactured to meet the requirements of BS EN 60598.2.22

Part No.	Legends
European signs directive, SI341 format	
RSE2X	
RSE3X	
RSE6X	
RSE120	PICK N MIX PACK
ISO 7010 legend format	
RSEN2X	
RSEN3X	
RSEN6X	
RSEN5X	
Arabic legend format	
RSB23DV	

Accessories

Order code	Description	Colour
BBZ	SEMI-RECESS BEZEL	
BWG	PROTECTIVE WIRE GUARD	

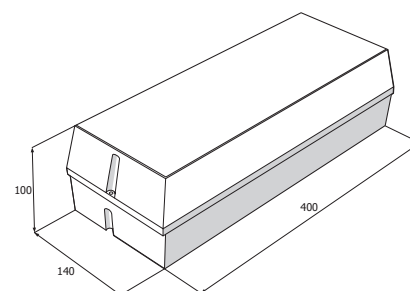

Wayfer

Functional & everyday



Slim-profile back-lit exit sign

- Manufactured from high graded polycarbonate
- Self adhesive legend creates back lit sign
- Ingress rated to IP42 wall mounted
- Easy to install

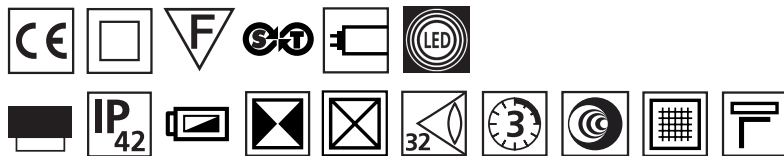

Luminaire

Order code	Input Voltage	Description	Lamptype	Operation / Duration (hrs)	Environment Temperature	Weight
PL2LS1	220-240Vac 50/60Hz	LED NM3 WH	1W LED strip	NM3	0-25 °C	1,7 kg
PL3LS1	220-240Vac 50/60Hz	LED M3 WH	1W LED strip	M3	0-25 °C	1,9 kg
PLX23111	220-240Vac 50/60Hz	FL NM3 WH	8W T5	NM3	0-25 °C	1,7 kg
PLX33111	220-240Vac 50/60Hz	FL M3 WH	8W T5	M3	0-25 °C	1,9 kg
CTPLX23111	220-240Vac 50/60Hz	CT-N 8WT5 NM3 WH	8W T5	NM3	0-25 °C	1,7 kg
CTPLX33111	220-240Vac 50/60Hz	CT-N 8WT5 M3 WH	8W T5	M3	0-25 °C	1,9 kg
PL13111HF	220-240Vac 50/60Hz	FL 230V50HZ HF WH	8W T5	230 V	0-25 °C	-
PL13111LTC	220-240Vac 50/60Hz	FL 230V50HZ LTC WH	8W T5	230 V	0-25 °C	-
PL1LS1HF	220-240Vac 50/60Hz	LED 230V50HZ HF WH	1W LED strip	230 V	0-25 °C	-
PL1LS1LTC	220-240Vac 50/60Hz	LED 230V50HZ LTC WH	1W LED strip	230 V	0-25 °C	-

Designed and manufactured to meet the requirements of BS EN 60598.2.22

Part No.	Legends
European signs directive, SI341 format	
RSE 2PL	
RSE 3PL	
RSE 6PL	
RSE 5PL	
ISO 7010 legend format	
RSEN 2PL	
RSEN 3PL	
RSEN 6PL	
RSEN 5PL	
Arabic legend format	
On request	

Accessories

Order code	Description
PL/WG	PROTECTIVE WIRE GUARD
PL/BCM	CEILING MOUNTING BRACKET

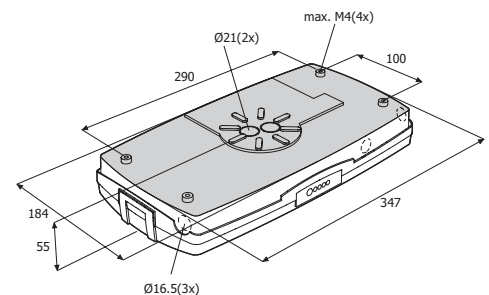

Wayfer

Functional & everyday



Luminaire

Slim-profile edge-lit exit sign

- Manufactured from high graded polycarbonate
- Self adhesive legend creates edge-lit sign
- Ingress rated to IP54
- Easy to install

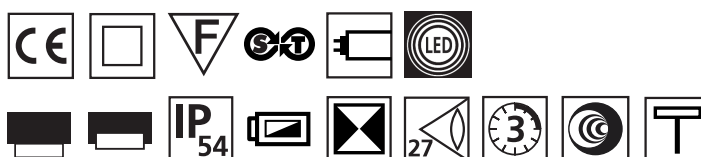

Order code	Input Voltage	Description	Lamp type	Power Consumption	Operation / Duration (hrs)	Environment Temperature	Weight
PL2LS1	220-240Vac 50/60Hz	LED NM3 WH	1W LED strip	12mA	NM3	0-25 °C	1,7 kg
PL3LS1	220-240Vac 50/60Hz	LED M3 WH	1W LED strip	27mA	M3	0-25 °C	1,9 kg
PLX23111	220-240Vac 50/60Hz	FL NM3 WH	8W T5	30mA	NM3	0-25 °C	1,7 kg
PLX33111	220-240Vac 50/60Hz	FL M3 WH	8W T5	60mA	M3	0-25 °C	1,9 kg

Designed and manufactured to meet the requirements of BS EN 60598.2.22

Single sided

Part No.	Legends
European signs directive, SI341 format	
XE02PL	
XE03PL	
XE06PL	
XE05PL	
ISO 7010 legend format	
XEN2PL	
XEN3PL	
XEN6PL	
XEN5PL	
Arabic legend format	
On request	

Accessories

Order code	Description
PL/BPM	PENDANT BRACKET, BACK MOUNT

Double sided

Part No.	Legends
European signs directive, SI341 format	
XE036PL	
XE022PL	
ISO 7010 legend format	
XEN36PLD	
XEN22PLD	
Arabic legend format	
On request	

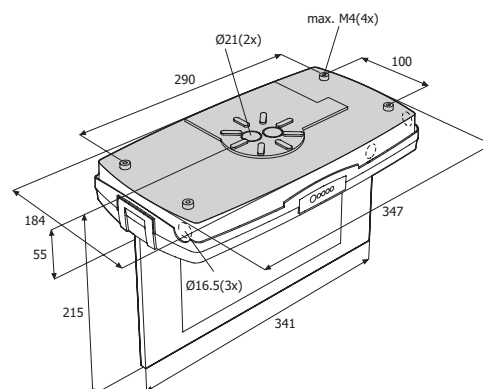
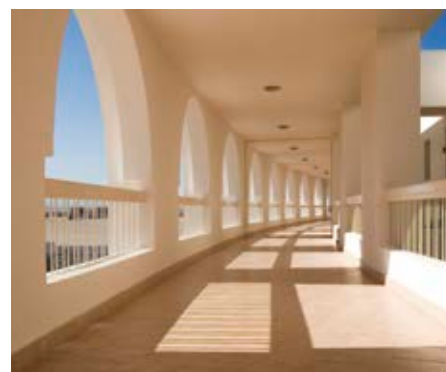

Day-lite Escape route signalisation



Slim-profile back-lit exit sign

- Manufactured from high graded polycarbonate
- Self adhesive legend creates back lit sign
- Ingress rated to IP42 wall mounted
- Easy to install

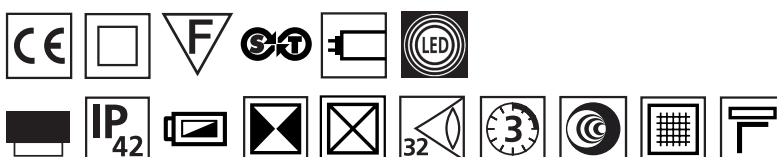

Luminaire

Order code	Input Voltage	Description	Lamp type	Lamp Output	Power Consumption	Operation / Duration (hrs)	Environment Temperature	Weight
XW2LS11	220-240Vac 50/60Hz	LED NM3 WH IP65	1W LED strip	90 lm	12mA	NM3	0-25 °C	1,1 kg
XW3LS11	220-240Vac 50/60Hz	LED M3 WH IP65	1W LED strip	90 lm	27mA	M3	0-25 °C	1,2 kg
XW23111	220-240Vac 50/60Hz	8WT5 NM3 WH IP65	8W T5	100 lm	30mA	NM3	0-25 °C	1,2 kg
XW33111	220-240Vac 50/60Hz	8WT5 M3 WH IP65	8W T5	100 lm	60mA	M3	0-25 °C	1,5 kg
XXW23111	220-240Vac 50/60Hz	SLIM BODY 8W NM3 IP65 3 CE	8W T5	170 lm	30mA	NM3	0-25 °C	1,2 kg
XXW33111	220-240Vac 50/60Hz	SLIM BODY 8W M3 IP65 3 CEL	8W T5	170 lm	60mA	M3	0-25 °C	1,1 kg
XW13111HF	220-240Vac 50/60Hz	230V50HZ HF WH	8W T5	300 lm	-	230 V	0-40 °C	1,5 kg
XW13111LTC	220-240Vac 50/60Hz	230V50HZ LTC WH	8W T5	300 lm	-	230 V	0-40 °C	1,5 kg
XW1LS11HF	220-240Vac 50/60Hz	LED 110-230V WH IP65	1W LED strip	300 lm	-	230 V	0-40 °C	1,5 kg
XW1LS11LTC	220-240Vac 50/60Hz	LED 230V50HZ LTC WH IP65	1W LED strip	300 lm	-	230 V	0-40 °C	1,5 kg
XWF13111HF	220-240Vac 50/60Hz	DAYLITE 8W230V HF FTOP IP65	8W T5	300 lm	-	230 V	0-40 °C	1,2 kg
XWF13111LTC	220-240Vac 50/60Hz	DAYLITE 8W230V LTC FTOP IP65	8W T5	300 lm	-	230 V	0-40 °C	1,2 kg

Designed and manufactured to meet the requirements of BS EN 60598.2.22

Part No.	Legends
European signs directive, SI341 format	
RSE2X	
RSE3X	
RSE6X	
RSE5X	
Arabic legend format	
On request	

Accessories

Order code	Description
XTR	SEMI-RECESS BEZEL IN WHITE

Day-lite Ex-cel

Surface mounted luminaire



Surface mounted luminaire

- Simple, vandal resistant design suitable for general use in interior and exterior locations
- Available with high grade polycarbonate (B) or cast aluminium (WA) enclosure
- Opal diffuser as standard with clear polycarbonate diffuser option available
- Converts easily to exit sign with addition of self-adhesive legend

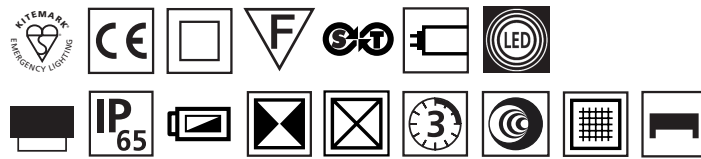

Luminaire

Order code	Input Voltage	Description	Lamptype	Lamp Output	Power Consumption	Operation / Duration (hrs)	Environment Temperature	Weight
XW2LS11	220-240Vac 50/60Hz	LED NM3 WH IP65	1W LED strip	90 lm	12mA	NM3	0-25 °C	1,1 kg
XW3LS11	220-240Vac 50/60Hz	LED NM3 WH IP65	1W LED strip	90 lm	27mA	M3	0-25 °C	1,3 kg
XXW23111	220-240Vac 50/60Hz	SLIM BODY 8W NM3 IP65 3 CE	8W T5	170 lm	30mA	NM3	0-25 °C	1,2 kg
XXW33111	220-240Vac 50/60Hz	SLIM BODY 8W M3 IP65 3 CEL	8W T5	170 lm	60mA	M3	0-25 °C	1,5 kg

Designed and manufactured to meet the requirements of BS EN 60598.2.22

Part No.	Legends
European signs directive, SI341 format	
RSE2X	
RSE3X	
RSE6X	
RSE5X	
Arabic legend format	
RSB23DV	



Accessories

Order code	Description
XTR	SEMI-RECESS BEZEL IN WHITE

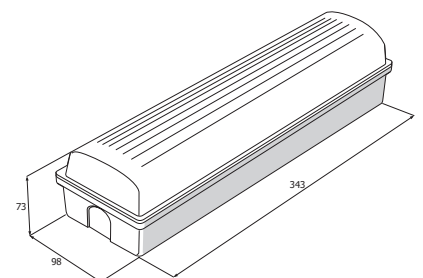

Cordona

High impact decorative luminaire



Surface mounted luminaire

- 28 Watt 2D high power luminaire
- Slim-line design for escape route and open area lighting
- Polycarbonate luminaire body with clear light optimised diffuser
- Hinged geartray for easy access

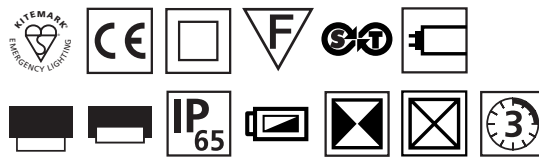

Luminaire

Order code	Input Voltage	Description	Lamp type	Lamp Output	Power Consumption	Operation / Duration (hrs)	Environment Temperature	Weight
CPW28NM	220-240Vac 50/60Hz	28W2D NM3 WH IP65	28W 2D	1800/250 lm	200/250mA	NM3	0-25 °C	3 kg
CPW28M	220-240Vac 50/60Hz	28W2D M3 WH IP65	28W 2D	1800/250 lm	200/250mA	M3	0-25 °C	3 kg
CPW28PHF	220-240Vac 50/60Hz	28W2D 230V WH IP65	28W 2D	1800 lm	200mA	NM3	0-25 °C	2.8 kg
CPW28PLTC	220-240Vac 50/60Hz	28W2D 230V LTC WH IP65	28W 2D	1800 lm	200mA	NM3	-	2.8 kg
CPW28V110	220-240Vac 50/60Hz	28W2D 110V WH IP65	28W 2D	1800 lm	-	M3	-	2.8 kg

Designed and manufactured to meet the requirements of BS EN 60598.2.22



14

Accessories

Order code	Description
CPW/BZ	SEMI-RECESS BEZEL IN WHITE

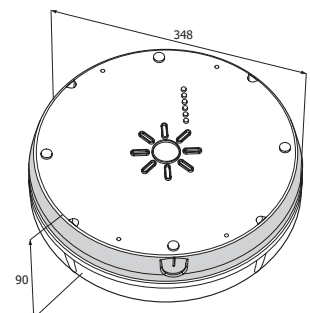

Silver-scape

Robust and durable



Recessed emergency exit sign

- Suitable for application in suspended ceilings
- Polycarbonate enclosure with wing fixings for recessed application
- Diffuser panel with slot for exit sign legend

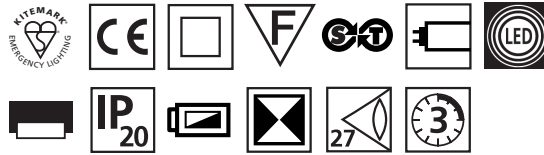

Luminaire

Order code	Input Voltage	Description	Lamptype	Operation / Duration (hrs)	Recharge Period	Environment Temperature	Weight
RB3LS1	220-240V50/60Hz	LED M3 IP20	1W LED Strip	M3	24 hrs	0-25 °C	1.3 kg
RB3311	220-240V50/60Hz	8WT5 M3 WH	8W T5	M3	24 hrs	0-25 °C	1.3 kg
RB1311HF	220-240V50/60Hz	230V50HZ HF	8W T5	230 V	-	0-40 °C	1.1 kg
RB1311LTC	220-240V50/60Hz	230V50HZ LTC	8W T6	230 V	-	0-40 °C	1.1 kg
RB1LS1HF	220-240V50/60Hz	LED 110-230V WH IP20	1W LED Strip	230 V	-	0-40 °C	1.1 kg
RB1LS1LTC	220-240V50/60Hz	LED 230V50HZ LTC WH IP20	1W LED Strip	230 V	-	0-40 °C	1.1 kg

Legends are screen printed. ISO 7010 format legends shown. Euro pictogram legends are available to order, please contact Emergi-Lite
 Designed and manufactured to meet the requirements of BS EN 60598.2.22

Single sided

Part No.	Legends
European signs directive, SI341 format	
XE02A31	
XE03A31	
XE06A31	
XE05A31	
ISO 7010 legend format	
XEN2A31	
XEN3A31	
XEN6A31	
XEN5A31	
Arabic legend format	
XB01A31	

Double sided

Part No.	Legends
European signs directive, SI341 format	
XE03/6A32	
ISO 7010 legend format	
XEN36A32	
Arabic legend format	
On request	



Accessories

Order code	Description
RE00	RECESSED SLOTTED DIFFUSER PANEL

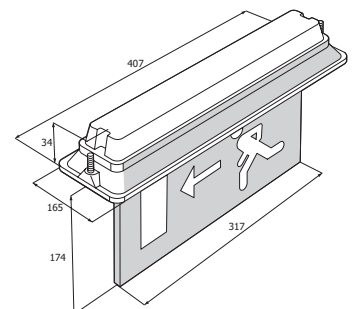

Silver-scape

Robust and durable



Recessed emergency luminaire

- Suitable for application in suspended ceilings
- Polycarbonate enclosure with wing fixings for recessed application
- Light engineered diffuser for optimum spacing

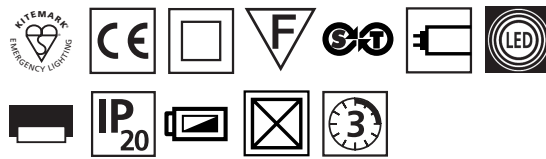

Luminaire

Order code	Input Voltage	Description	Lamp type	Lamp Output	Power Consumption	Operation / Duration (hrs)	Recharge Period	Environment Temperature	Weight
RB2LS1	220-240V50/60Hz	LED NM3 IP20	1 W LED strip	90 lm	12mA	NM3	24 hrs	0-25 °C	1.8 kg
RB3LS1	220-240V50/60Hz	LED M3 IP20	1 W LED strip	100 lm	27mA	NM3	24 hrs	0-25 °C	1.8 kg
RB2311	220-240V50/60Hz	8WT5 NM3 WH	8W T5	100 lm	30mA	230 V	-	0-25 °C	1.8 kg
RB3311	220-240V50/60Hz	8WT5 M3 WH	8W T5	90 lm	60mA	230 V	-	0-25 °C	1.8 kg
RB1311HF	220-240V50/60Hz	230V50HZ HF	8W T5	100 lm	60mA	230 V	-	0-25 °C	1.8 kg
RB1311LTC	220-240V50/60Hz	230V50HZ LTC	8W T5	90 lm	-	230 V	-	0-25 °C	1.8 kg
RB1LS1LTC	220-240V50/60Hz	LED 230V50HZ LTC WH IP20	1 W LED strip	90 lm	-	230 V	-	0-25 °C	1.8 kg
RB1LS1HF	220-240V50/60Hz	LED 110-230V WH IP20	1 W LED strip	100 lm	-	NM3	24 hrs	0-25 °C	1.8 kg

Designed and manufactured to meet the requirements of BS EN 60598.2.22



Accessories

15

Order code	Description	Colour
RB00	WHITE TRIM	

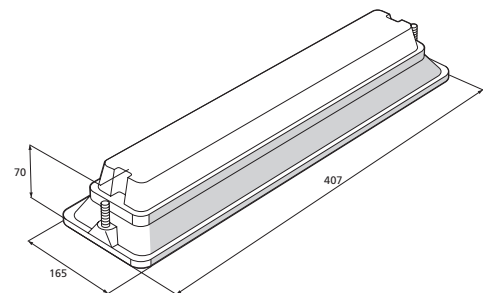

Aqualux

Escape route signalisation



Back-lit LED exit sign

- Robust contemporary design, ideal for offices, warehouses and storage facilities
- Attractive aluminium modular enclosure (certified to IP65 and IP67)
- Clear polycarbonate broad delivery diffuser
- Intelligent Self-Test as standard

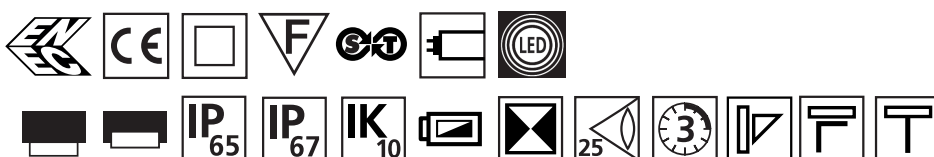

Luminaire

Order code	Input Voltage	Description	Lamptype	Power Consumption	Operation / Duration (hrs)	Recharge Period	Environment Temperature	Weight
OW33161	220-240Vac,50Hz	AQUALUX 8WM3 IP65	8W T5	90mA	M3	24 hrs	0-25 °C	2.2 kg
OW36161	220-240Vac,50Hz	AQUALUX 11WM3 SLFTST IP65	11W PL	120mA	M3	24 hrs	0-25 °C	2.2 kg
OW3L261	220-240Vac,50Hz	AQUALUX 2LED M3	2 x 1W LED	60mA	M3	24 hrs	0-25 °C	2.2 kg
OW3L261V2	220-240Vac,60Hz	AQUALUX 2LED M3 220V60HZ	2 x 1W LED	60mA	M3	24 hrs	0-25 °C	2.2 kg
CTOW33161	220-240Vac,50Hz	AQUALUX 8WM3 CT IP65	11W PL	-	M3	24 hrs	0-25 °C	2.2 kg
CTOW36161	220-240Vac,50Hz	AQUALUX 11WM3 CT IP65	2 x 1W LED	-	M3	24 hrs	0-25 °C	2.2 kg
CTSTF23161	220-240Vac,50Hz	CENTRAL AQUA FREEZ-LITE 8WNM3	2 x 1W LED	-	M3	24 hrs	0-25 °C	2.2 kg
CTSTF3L261	220-240Vac,50Hz	FREEZ-LITE CT 2LED M3	8W T5	70mA	M3	24 hrs	0-25 °C	2.2 kg
OW13161HF	220-240Vac,50/60Hz	AQUALUX 8W230V50HZ IP65	8W T5	70mA	230 V	-	0-40 °C	1.8 kg
OW13161LTC	220-240Vac,50/60Hz	AQUALUX 8W 230V LTC, IP65	11W PL	30mA	230 V	-	0-40 °C	1.9 kg
OW16161HF	220-240Vac,50/60Hz	AQUALUX 11W230V HF IP65	2 x 1W LED	100mA	230 V	-	0-40 °C	1.8 kg
OW1L261HF	220-240Vac,50/60Hz	AQUALUX 2XLED SIGN 230VHF	2 x 1W LED	30mA	230 V	-	0-40 °C	1.9 kg
OW1L261LTC	220-240Vac,50/60Hz	AQUALUX 8WM3 IP65	-	-	-	-	-	-

Designed and manufactured to meet the requirements of BS EN 60598.2.22

Single sided

Part No.	Legends
European signs directive, SI341 format	
XE02A31	
XE03A31	
XE06A31	
XE06A31	
Arabic legend format	
XB01A31	

Accessories

Order code	Description
OW/BCM	CEILING BRACKET VERTICAL MOUNT
OW/BCR	RECESSED BEZEL KIT
OW/BWA	WALL BRACKET ANGLE MOUNT
OW/BWM	WALL BRACKET END CANTILEVER
OW/CVR	OW CLR COVER + FRESNEL
OW/DSC	DIFFUSER DS BANK

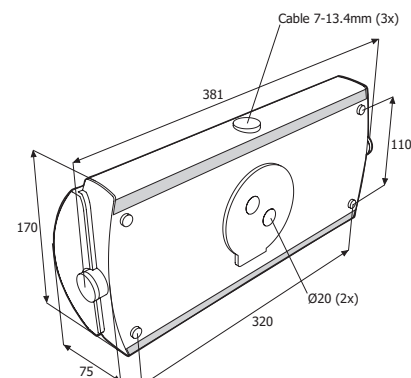

Aqualux

Escape route signalisation - convex



Edge-lit LED exit sign

- Robust contemporary design, ideal for offices, warehouses and storage facilities
- Attractive aluminium modular enclosure (certified to IP65 and IP67)
- Clear polycarbonate broad delivery diffuser
- Intelligent Self-Test as standard

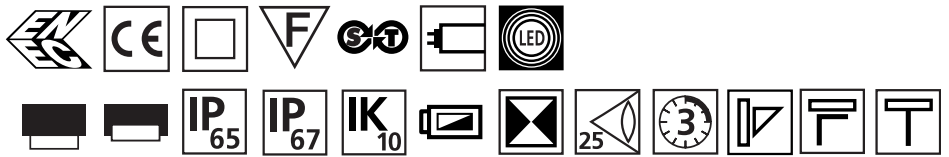

Luminaire

Order code	Input Voltage	Description	Lamptype	Power Consumption	Operation / Duration (hrs)	Recharge Period	Environment Temperature	Weight
OW33161	220-240Vac,50Hz	AQUALUX 8WM3 IP65	8W T5	90mA	M3	24 hrs	0-25 °C	2.2 kg
OW36161	220-240Vac,50Hz	AQUALUX 11WM3 SLTST IP65	11W PL	120mA	M3	24 hrs	0-25 °C	2.2 kg
OW3L261	220-240Vac,50Hz	AQUALUX 2LED M3	2 x 1W LED	60mA	M3	24 hrs	0-25 °C	2.2 kg
OW3L261V2	220-240Vac,60Hz	AQUALUX 2LED M3 220V60HZ	2 x 1W LED	60mA	M3	24 hrs	0-25 °C	2.2 kg
CTOW33161	220-240Vac,50Hz	AQUALUX 8WM3 CT IP65	11W PL	-	M3	24 hrs	0-25 °C	2.2 kg
CTOW36161	220-240Vac,50Hz	AQUALUX 11WM3 CT IP65	2 x 1W LED	-	M3	24 hrs	0-25 °C	2.2 kg
CTSTF23161	220-240Vac,50Hz	CENTRAL AQUA FREEZ-LITE 8WNM3	2 x 1W LED	-	M3	24 hrs	0-25 °C	2.2 kg
CTSTF3L261	220-240Vac,50Hz	FREEZ-LITE CT 2LED M3	8W T5	70mA	M3	24 hrs	0-25 °C	2.2 kg
OW13161HF	220-240Vac,50/60Hz	AQUALUX 8W230V50HZ IP65	8W T5	70mA	230 V	-	0-40 °C	1.8 kg
OW13161LTC	220-240Vac,50/60Hz	AQUALUX 8W 230V LTC, IP65	11W PL	30mA	230 V	-	0-40 °C	1.9 kg
OW16161HF	220-240Vac,50/60Hz	AQUALUX 11W230V HF IP65	2 x 1W LED	100mA	230 V	-	0-40 °C	1.8 kg
OW1L261HF	220-240Vac,50/60Hz	AQUALUX 2XLED SIGN 230VHF	2 x 1W LED	30mA	230 V	-	0-40 °C	1.9 kg
OW1L261LTC	220-240Vac,50/60Hz	AQUALUX 8WM3 IP65	-	-	-	-	-	-

Designed and manufactured to meet the requirements of BS EN 60598.2.22

Single sided

Part No.	Legends
European signs directive, SI341 format	
RSE2W	
RSE3W	
RSE6W	
RSE5W	
Arabic legend format	
XB01A31	

Double sided

Part No.	Legends
European signs directive, SI341 format	
RSE2W/RSE2W	
ISO 7010 legend format	
RSE3W/RSE3W	
Arabic legend format	
On request	

Accessories

Order code	Description
OW/BCM	CEILING BRACKET VERTICAL MOUNT
OW/BCR	RECESSED BEZEL KIT
OW/BWA	WALL BRACKET ANGLE MOUNT
OW/BWM	WALL BRACKET END CANTILEVER
OW/CVR	OW CLR COVER + FRESNEL
OW/DSC	DIFFUSER DS BANK

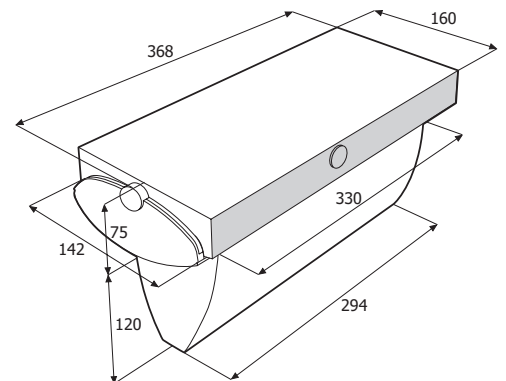

Aqualux

Escape route signalisation



High power open area luminaire

- Robust contemporary design, ideal for offices, warehouses and storage facilities
- Choice of 8 W or 11 W fluorescent lamps
- Attractive aluminium modular enclosure (certified to IP65 and IP67)
- Clear polycarbonate broad delivery diffuser

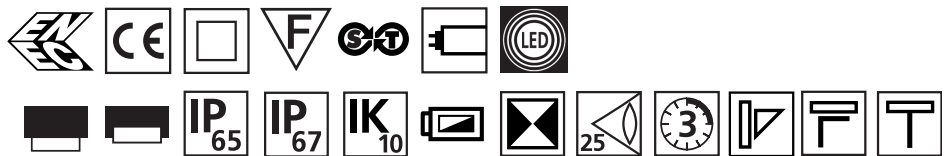

Luminaire

Order code	Input Voltage	Description	Lamp type	Power Consumption	Operation / Duration (hrs)	Recharge Period	Environment Temperature	Weight
OW23161	220-240Vac,50Hz	AQUALUX 8WNM3 IP65	8W T5	40mA	NM3	24 hrs	0-25 °C	2.2 kg
OW23161V2	220-240Vac,60Hz	AQUALUX 8WNM3 IP65 110V60HZ	8W T5	40mA	NM3	24 hrs	0-25 °C	2.2 kg
OW26161	220-240Vac,50Hz	AQUALUX 11WNM3 SLFTST IP65	11W PL	40mA	NM3	24 hrs	0-25 °C	2.2 kg
OW33161	220-240Vac,50Hz	AQUALUX 8WM3 IP65	8W T5	90mA	M3	24 hrs	0-25 °C	2.2 kg
OW36161	220-240Vac,50Hz	AQUALUX 11WM3 SLFTST IP65	11W PL	120mA	M3	24 hrs	0-25 °C	2.2 kg
OW3L261	220-240Vac,50Hz	AQUALUX 2LED M3	2 x 1W LED	60mA	M3	24 hrs	0-25 °C	2.2 kg
OW3L261V2	220-240Vac,60Hz	AQUALUX 2LED M3 220V60HZ	2 x 1W LED	60mA	M3	24 hrs	0-25 °C	2.2 kg
CTOW23161	220-240Vac,50Hz	AQUALUX 8WM3 CT IP65	11W PL	-	NM3	24 hrs	0-25 °C	2.2 kg
CTOW26161	220-240Vac,50Hz	AQUALUX 11WM3 CT IP65	8W T5	-	NM3	24 hrs	0-25 °C	2.2 kg
CTOW33161	220-240Vac,50Hz	AQUALUX 8WM3 CT IP65	11W PL	-	M3	24 hrs	0-25 °C	2.2 kg
CTOW36161	220-240Vac,50Hz	AQUALUX 11WM3 CT IP65	2 x 1W LED	-	M3	24 hrs	0-25 °C	2.2 kg
CTOW3L261	220-240Vac,50Hz	AQUALUX CT 2LED M3	8W T5	-	M3	24 hrs	0-25 °C	2.2 kg
CTSTF23161	220-240Vac,50Hz	CENTRAL AQUA FREEZ-LITE 8WNM3	2 x 1W LED	-	NM3	24 hrs	0-25 °C	2.2 kg
CTSTF3L261	220-240Vac,50Hz	FREEZ-LITE CT 2LED M3	8W T5	-	M3	24 hrs	0-25 °C	2.2 kg
OW13161HF	220-240Vac,50/60Hz	AQUALUX 8W230V50HZ IP65	8W T5	70mA	230 V	-	0-40 °C	1.8 kg
OW13161LTC	220-240Vac,50/60Hz	AQUALUX 8W 230V LTC, IP65	11W PL	30mA	230 V	-	0-40 °C	1.9 kg
OW16161HF	220-240Vac,50/60Hz	AQUALUX 11W230V HF IP65	2 x 1W LED	100mA	230 V	-	0-40 °C	1.8 kg
OW1L261HF	220-240Vac,50/60Hz	AQUALUX 2XLED SIGN 230VHF	2 x 1W LED	30mA	30 V	-	0-40 °C	1.9 kg
OW1L261LTC	220-240Vac,50/60Hz	AQUALUX 8WM3 IP65	-	-	-	-	-	-

Designed and manufactured to meet the requirements of BS EN 60598.2.22

Accessories

Order code	Description
OW/BCM	CEILING BRACKET VERTICAL MOUNT
OW/BCR	RECESSED BEZEL KIT
OW/BWA	WALL BRACKET ANGLE MOUNT
OW/BWM	WALL BRACKET END CANTILEVER
OW/CVR	OW CLR COVER + FRESNEL

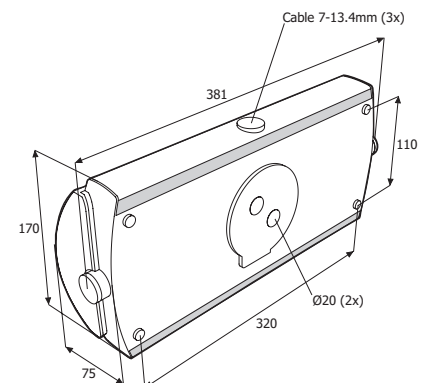

Portable Work-Lite

Portable emergency luminaire



Portable Work-Lite emergency luminaire

- High brightness, high power, focused beam LED light source
- Ideal for installers, maintenance or security personnel
- Durable polycarbonate body with clear polycarbonate diffuser
- Half power illumination (45 lumens for 3 hours) or full power (100 lumens for hour)
- Carrying handle with variable ratchet positioning

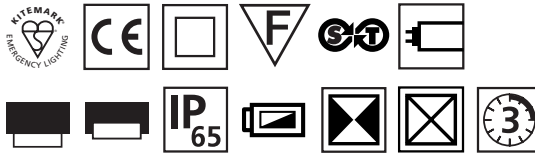

Luminaire

Order code	Input Voltage	Description	Lamp type	Lamp Output	Recharge Period	Operation / Duration (hrs)	Environment Temperature	Weight
CPW28V110	220-240Vac 50/60Hz	PORTABLE LED	LED	100/45 lm	24 hours	NM1/M3	0-25 °C	0.7 kg

Designed and manufactured to meet the requirements of BS EN 60598.2.22



Accessories

Order code	Description
CPW/BZ	SEMI-RECESS BEZEL IN WHITE

Range-Lite

Twin beam emergency lighting



Twin beam emergency lighting (20w)

- Ideal for indoor use in smaller warehouses, factory spaces and industrial open areas
- Can be mounted upright on a wall or stanchion
- 20 Watt tungsten halogen lamps with polycarbonate lenses
- Mild steel enclosure with white powder coat
- Optional battery retaining clamp, or time delay feature

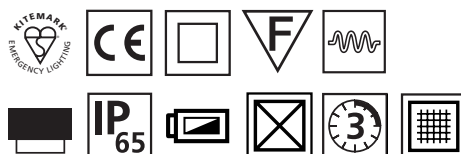

Luminaire

Order code	Input Voltage	Description	Lamp type	Power Consumption	Operation / Duration (hrs)	Environment Temperature	Weight
HV183	220-240Vac 50/60Hz	2X18W NM3	2 X 18/W TH	100mA	NM3	0-25 °C	7.8 kg
HV203	220-240Vac 50/60Hz	2X20W NM3	2 X 20W TH	100mA	NM3	0-25 °C	7.8 kg
HVCB230HF	220-240Vac 50/60Hz	2X20W 230VAC HOR	2 X 20W TH	200mA	230 V	0-25 °C	7.8 kg
HVCB230LTC	220-240Vac 50/60Hz	LTC 2 X 20W TWINSPO.	2 X 20W TH	-	230 V	-	7.8 kg

Designed and manufactured to meet the requirements of BS EN 60598.2.22

Options

Order code	Description
On request	RUN ON TIMER (20 W VERSION ONLY) TO SUPPORT SLOW START MAINS LUMINAIRES



Accessories

Order code	Description
HVBC	BATTERY RETAINING CLAMP
HLWG	PROTECTIVE WIRE GUARD

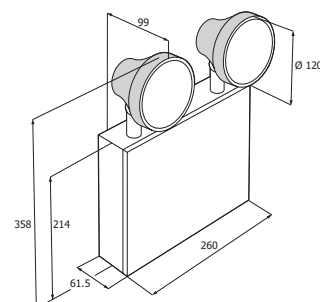

Range-Lite

Twin beam emergency lighting



Portable emergency luminaire

- Ideal for indoor use in larger warehouses, factory spaces and industrial open areas
- Can be mounted upright on a wall or stanchion
- 55 Watt tungsten halogen lamps
- Mild steel enclosure
- Single lamp option available

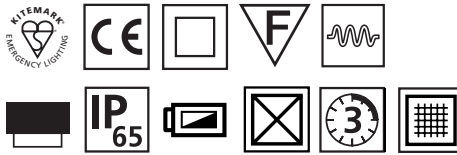

Luminaire

Order code	Input Voltage	Description	Lamp type	Lamp Output	Power Consumption	Recharge Period	Operation / Duration (hrs)	Environment Temperature	Weight
HL203E3	220-240Vac 50/60Hz	RANGE LITE 2X20W NM3 IP65	2 x 20W TH	600 lm	100mA	24 hours	NM3	0-25 °C	7.8 kg
HL551E3	220-240Vac 50/60Hz	RANGE LITE 2X55W NM1 IP65	1 x 55W TH	1800 lm	100mA	24 hours	NM3	0-25 °C	7.8 kg
HLCB55230LTC	220-240Vac 50/60Hz	RANGE LITE 2X55W 230V LTC	2 x 55W TH	-	-	-	230 V	0-25 °C	7.8 kg

Designed and manufactured to meet the requirements of BS EN 60598.2.22

Options

Order code	Description
On request	RUN ON TIMER (20 W VERSION ONLY) TO SUPPORT SLOW START MAINS LUMINAIRES



Accessories

Order code	Description
CPW/BZ	SEMI-RECESS BEZEL IN WHITE

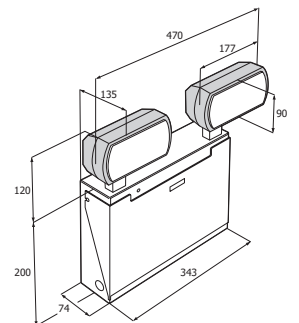

Range-Lite

Robust and high output



Twin beam emergency lighting

- Rated for external use with battery and electronics enclosure sealed to IP65
- Remote mounting lamps with horizontal and vertical head adjustment
- Polycarbonate enclosure with screw locked front panel
- Meets the anti-glare requirement when projectors mounted at least 30° above the line of sight

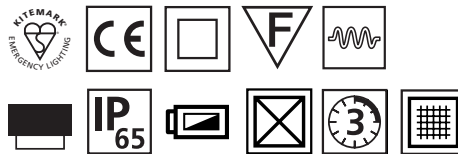

Luminaire

Order code	Input Voltage	Description	Lamp type	Power Consumption	Recharge Period	Operation / Duration (hrs)	Environment Temperature	Weight
HL1553	220-240Vac 50/60Hz	RANGE LITE 1X55W 3HR	1 x 55W TH	100mA	24 hours	NM3	0-25 °C	7.8 kg
HL551PC	220-240Vac 50/60Hz	RANGELITE 2X55W NM1 PC LENS	2 x 55W TH	100mA	24 hours	NM3	0-25 °C	7.8 kg
HL551	220-240Vac 50/60Hz	RANGE LITE 2X55W 1HR	2 x 55W TH	100mA	24 hours	NM1	0-25 °C	7.8 kg

Designed and manufactured to meet the requirements of BS EN 60598.2.22

Options

Order code	Description
On request	RUN ON TIMER (20 W VERSION ONLY) TO SUPPORT SLOW START MAINS LUMINAIRES

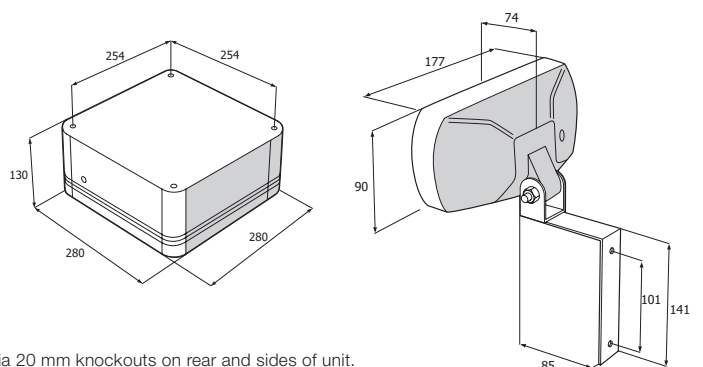

Cable entry via 20 mm knockouts on rear and sides of unit.

For your notes

A series of horizontal dotted lines for taking notes.

For your notes

A series of horizontal dotted lines for taking notes.

Contact us

Thomas & Betts Ltd. Br.

Office 724 6WA West Wing
Dubai Airport Free Zone
PO Box 54567
Dubai
United Arab Emirates
T +971 (0)4 609 1635
F +971 (0)4 609 1636
E enquiry@tnb.com

Thomas & Betts Saudi Arabia

Building 128
Dammam Industrial Area #2
PO Box 514
Al Khobar 31952
Saudi Arabia
T +966 (0)3 812 1222
T +966 (0)3 812 2981
E enquiry@tnb.com

www.abb.com/lowvoltage

Note: We reserve the right to make technical changes or modify the contents of this document without prior notice. With regard to purchase orders, the agreed particulars shall prevail. ABB AG does not accept any responsibility whatsoever for potential errors or possible lack of information in this document.

We reserve all rights in this document and in the subject matter and illustrations contained therein. Any reproduction, disclosure to third parties or utilization of its contents – in whole or in parts – is forbidden without prior written consent of ABB AG.

Copyright © 2015

ABB Business Unit: Protection, Connection & Wire Management
All rights reserved