

MEMBRANE SPECIFICATION

Colour:
black (top)

Weight:
392 g/m²
(including liner)

Dimensions:
Roll size: 1.5m x 50m

I OVERVIEW

WRAPTITE UV MEMBRANE

- Wraptite UV is a Class B-s2,d0* fire rated membrane that combines the best properties of vapour permeability and air tightness in one innovative, self-adhering product, which is specifically designed for use behind open jointed cladding.
- Wraptite UV combines exceptional water resistance and UV resistance to provide a “shadow” appearance within open rainscreen façades. Manufactured from polyester and a functional coating, with a proprietary acrylic moisture vapour permeable adhesive and silicone-coated PET release liner.
- Wraptite UV bonds (no mechanical attachment) to multiple substrates for air tightness and ease of installation, negating the requirement for a primer, sealants or tapes. Adhesive curing time is approximately 6hrs depending on environmental conditions.
- Wraptite UV prevents lateral air movement enhancing the buildings thermal performance. With a rating of SD 0.060m it provides a high vapour permeability in a commercial quality, self-adhered, airtight breathable membrane.
- To protect the membrane from mechanical damage, the joint openings in the façade covering have to be less than 40% of the area, and maximum 50mm wide.

WRAPTITE LIQUID FLASHING (LF) Black

- Wraptite Liquid Flashing (LF) Black is a high-quality, gunable, low-odour, elastomeric, polyether, liquid-applied flashing and detailing membrane.
- Wraptite LF Black bonds easily to multiple substrates. 1 x 600ml Wraptite LF Black sausage covers approx. 1.4 - 1.8m². Product skins within 30 minutes at 21°C (70°F) and 50% relative humidity. Low temperatures + low relative humidity will slow drying time. High temperatures + high relative humidity will accelerate drying time. Coverage rates will vary depending on the substrate. Primer is not required.
- Wraptite LF Black is compatible with the entire range of A. Proctor Group’s vapour permeable products and is ideal for use in complex details. It may also be used to protect the leading edge of Wraptite UV membrane, tape and corners from water ingress if those edges cannot be protected by overlapping in a shingle fashion.

* Tested over 12mm calcium silicate board to EN 13238:2010

STORAGE & HANDLING

- Wraptite UV must be protected from rain and physical damage. Pallets of the membrane must be stored in dry areas away from heat, sparks and flame, with allowances for adequate ventilation. Pallets must not be double -stacked. Rolls of Wraptite must be stored vertically.
- Store only as much material at point of use as is required for each day’s usage in temperatures not exceeding 32° C for extended periods.

ACCESSORIES REQUIRED

- Wraptite LF Black
- Wraptite UV Tape
- Wraptite UV Tape Split Liner
- Wraptite UV Corners

2 TOOLS REQUIRED

- | | | |
|-------------------------------|------------------|-----------------------------|
| • Utility Knife | • Stiff Brush | • Putty Knife |
| • Hand-Held Heavy Duty Roller | • Marker Pen | • Foil Applicator Gun 600ml |
| | • Measuring Tape | • Clean Cloth |
| | • Scissors | |

3 SUBSTRATE PREPARATION

- Substrate condition is critical to the adhesive performance of any self-adhered membrane or liquid-applied flashing.
- Surfaces must be clean, dry and free from all bond-breaking contaminants, sharp protrusions or other matter that may hinder adhesion to the substrate. Clean any loose dust or dirt from the substrate by wiping with a clean dry cloth or brush. Remove and replace any damaged structural wall components.

WRAPTITE UV MEMBRANE, TAPE & CORNERS

- Can be applied to various substrates including:

> Aluminium (Painted, Powder Coated, Mill Finish)	> In-Situ Concrete
> Anodised Aluminium	> OSB
> Concrete Block	> Precast Concrete
> Exterior Grade Gypsum / Fibre Board	> Pre-Painted Steel
> Galvanised Metal	> Rigid Vinyl
	> Steel
	> Plywood

WRAPTITE LIQUID FLASHING (LF) Black:

- Can be applied to various substrates including:
 - > Aluminium (Painted, Powder Coated, Mill Finish)
 - > Exterior Sheathing
 - > Concrete
 - > Vinyl
 - > Brick
 - > Wood

4 INSTALLATION: BEST PRACTICE

- Building design requirements should be considered prior to application of Wraptite UV to minimise waste. Penetrations/openings will need to be correctly detailed to ensure a weather and air tight installation.
- Keep Wraptite UV in the original packaging which also functions as a dispenser. Wraptite UV is easily cut to desired lengths and can be installed in either a vertical or horizontal orientation. Use a hand roller and stiff brush to ensure an effective bond with the substrate.
- **IMPORTANT:** Failure to roller the membrane effectively may result in poor adhesion to the substrate. Poor adhesion may result in air pockets (bubbles) appearing, especially when Wraptite UV is facing into direct sunlight. To remedy this, use a hand-held heavy duty roller over the bubbles ensuring a proper bond to the substrate is achieved.
- Always install with an overlap, with the upper courses lapped over lower courses. Wraptite UV installed around penetrations such as windows and doors must be installed in the correct sequence to ensure an overlapping “shingled” result.
- All horizontal and vertical overlaps must be a minimum of 75mm. Vertical overlaps should be staggered from floor-to-floor or separated by a horizontally applied Wraptite UV strip. Internal and external vertical corners should have a minimum overlap of 150mm.
- At the end of each working day, protect the leading edge of Wraptite UV with a temporary tarpaulin to ensure liquid water does not seep behind the membrane.
- Wraptite UV should only be applied in dry weather when air and surface temperatures are above -10°C. Do not install Wraptite UV in adverse weather conditions.
- Wraptite UV should be covered with the final external protective layer (i.e.: cladding, roofing) within 12 months (Central European Climate). If exceeding this limit is unavoidable, protect Wraptite UV from the elements with a tarpaulin.
- All walling and roofing membranes require protection from heavy/prolonged rainfall and extreme weather events while being installed. Waterproofing materials (e.g. tarpaulins) should be utilised as necessary to ensure the leading edges of all membranes and interior spaces are protected until the primary cladding and roofing is in place.
- Wraptite Liquid Flashing Black is not for use in place of Wraptite UV Membrane, as a structural sealant, or in locations below ground or that will be continuously in contact with water.

5 HORIZONTAL INSTALLATION (2-person method)

1. Snap chalkline for guidance.
2. Pre-cut material to required length.
3. Roll cut length with release paper outwards.
4. Starting at corner, peel back release paper by approx 150mm. (Fig.1)
5. Fold release paper back, and using a hand-held heavy duty roller or stiff brush, lightly apply the exposed glue surface to the prepared substrate.
6. Starting in the middle, use hand-held heavy duty roller or stiff brush to smooth out any air bubbles, releasing the air to each side.

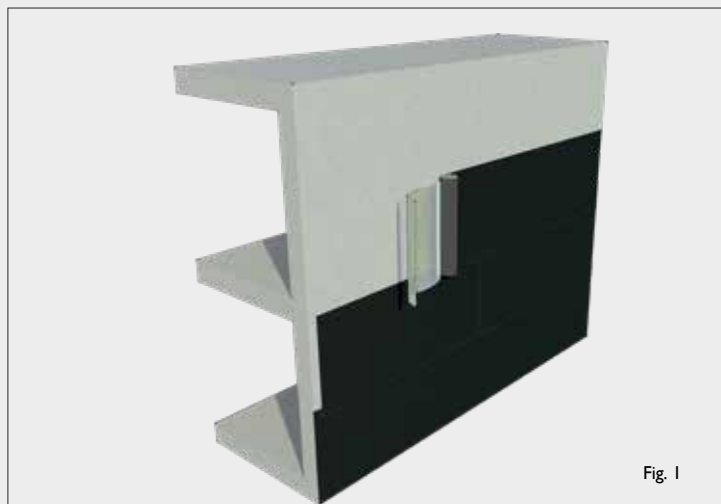

Fig. 1

6 VERTICAL INSTALLATION (1-person method)

FOLLOW PRECEDING STEPS 1-5, THEN:

6. Allow rest of rolled up material to drop down - with release paper still attached. Check for proper alignment (Fig.2).
7. When aligned, use hand-held heavy duty roller or stiff brush across the entire adhered section.
8. Drop roll down, pulling off release paper:
9. Smooth out air bubbles with stiff brush / hand-held heavy duty roller
10. Proceed with next row, ensuring minimum 75mm overlap, always in shingled fashion.

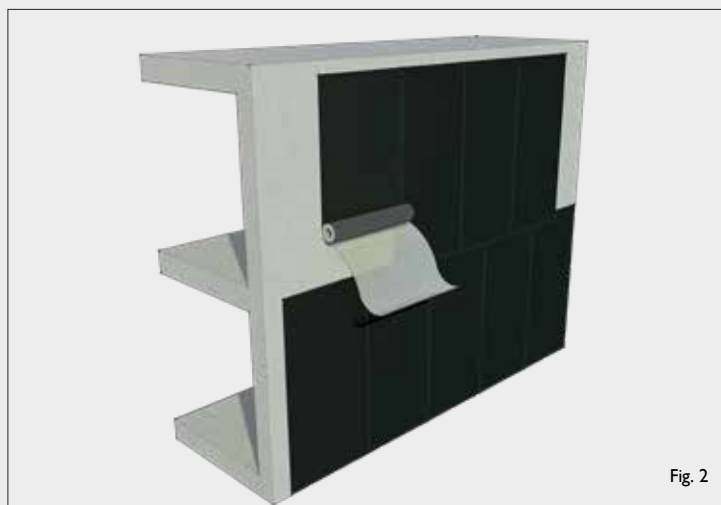

Fig. 2

TECHNICAL ADVICE

The A. Proctor Group has a dedicated Technical Department which can help with installation details, view drawings for approval and give specialist advice on the correct use of the A. Proctor Group products.

Telephone: +44 (0)1250 872261
Email: contact@proctorgroup.com
Website: www.proctorgroup.com

7 WALL & FLOOR CONNECTIONS

1. Apply 150mm Wraptite UV Split Liner Tape to the bottom edge of the wall panel. Create a flap by adhering the top half of the Tape only using the release liner. Roller top edge well. (Fig.3)
2. Use masking tape to hold down the flap temporarily. Apply Wraptite UV Membrane to the rest of the wall panel.
3. On site, remove masking tape. Use a 300mm wide strip of Wraptite UV Membrane to seal the floor zone and to make a shingled connection between floor and walls. (Fig.4-5)

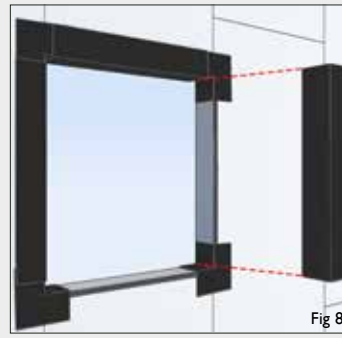
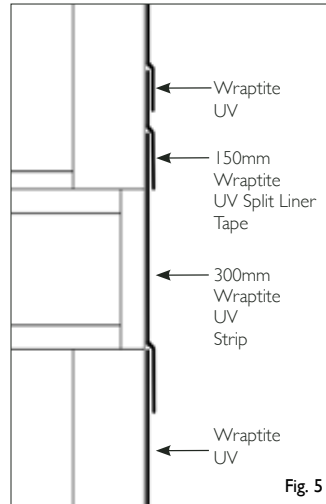
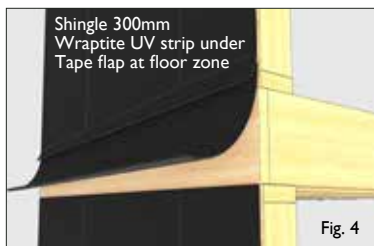
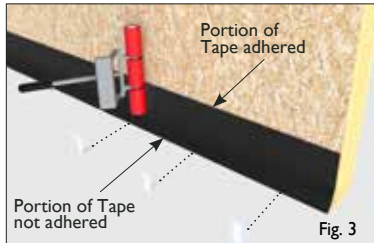

9 WALL PENETRATIONS

1. Fill joints, gaps and cracks with Wraptite LF Black and smooth across the rough surface with a putty knife (Fig.10,12,14).
2. Install Wraptite UV Membrane up to the penetration edges.
3. Opt 1: Apply a thick bead of Wraptite LF Black around the penetration and smooth with a putty knife ensuring a min. 100-150mm spread making contact with the penetration, and membrane (Fig.11,13).
4. Opt 2: Use 150mm Wraptite UV Split Liner Tape to seal penetrations by folding half the tape onto the membrane and the other half onto the penetration. Seal corner seam with Wraptite LF Black (Fig.15)

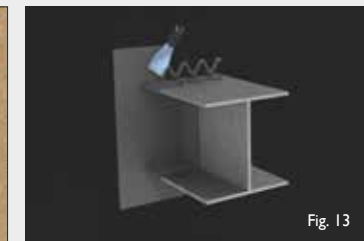
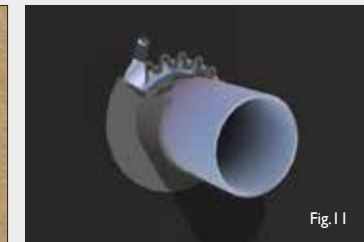

8 WINDOW & DOOR OPENINGS

1. Pre-fill joints, gaps and cracks >6mm with a bead of Wraptite LF Black and allow to cure fully; (Fig.6)
2. Fill remaining joints, gaps and cracks <6mm with Wraptite LF Black and smooth across the rough surface with a putty knife.
3. Finish door and window detailing using pre-formed Wraptite UV Corners and Wraptite UV Split Liner Tape (Figs.7-9).

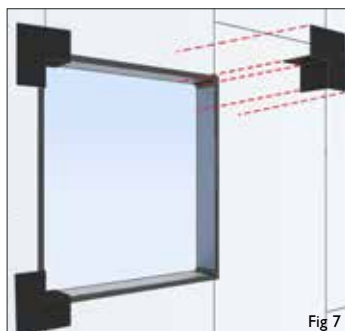
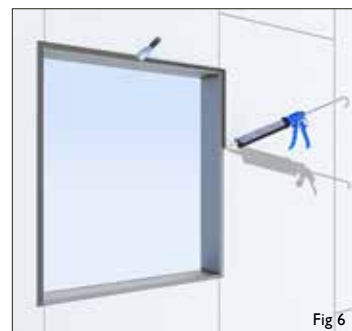

TROUBLESHOOTING & COMPLIANCE

Creases & Bubbles

Wraptite UV Membrane should be rolled out and pressed flat to the substrate as much as possible to avoid creating air pockets and bubbles. Some creases are unavoidable. When a significant rise in temperature and/or direct solar radiation are expected within 12 hours of installation, prior to the adhesive fully curing, the risk of bubbling is greater so extra care must be taken.

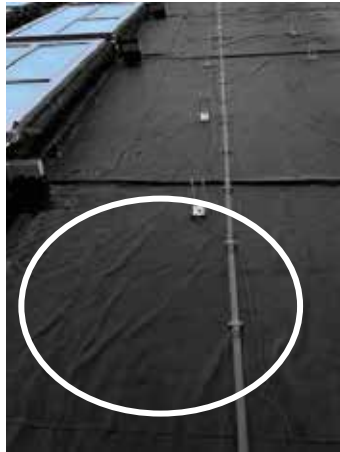

Exposed Substrate

Large tears and awkward wall penetrations can result in the substrate being left exposed. Seal substrate using Wraptite UV Tape with a minimum 75mm overlap &/or Liquid Flashing.

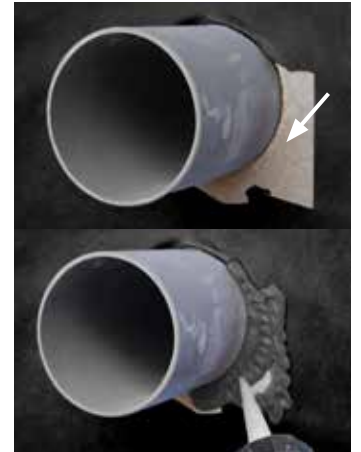

Small Punctures & Tears

Fixings that are flush or penetrate through the Membrane should be treated with minimum 75mm wide Wraptite UV Tape. Small tears should be similarly repaired.

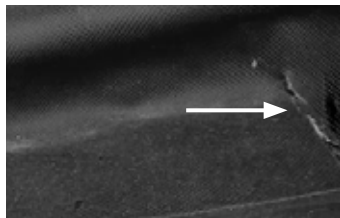
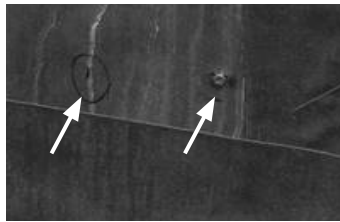

Reverse Shingle

In areas where a reverse shingle effect has occurred, treat either with Wraptite UV Tape ensuring the overlap onto the surface is a minimum of 75mm, or apply a generous bead of Wraptite LF Black to the leading edges of the Membrane and smooth over.

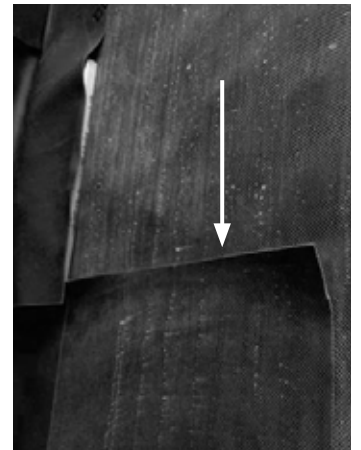

Peel-back & Delamination

Remediate areas of peel-back with Wraptite UV Tape ensuring a 75mm overlap. If the membrane has lost its adhesion strength, remove the material completely and replace.

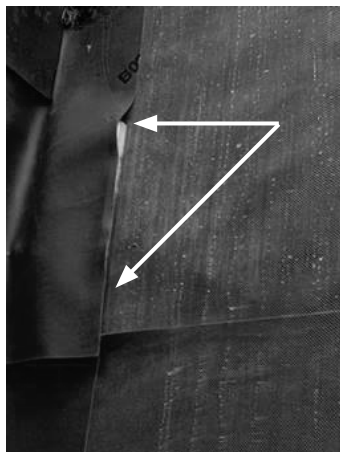

Incomplete Detailing

Areas around window bottoms must be fully lapped under with the Membrane. Remove any excess material.

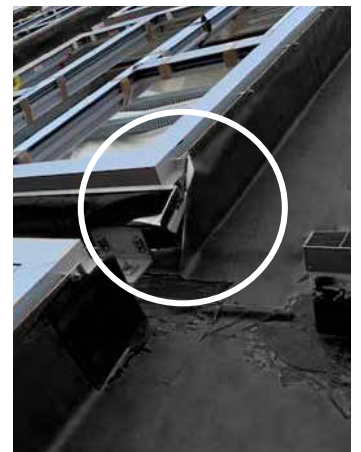

CONTACT

Telephone:
+44 (0)1250 872261

Email:
contact@proctorgroup.com

Website:
www.proctorgroup.com