

Chroma-Q® Studio Force™ V12 / T12 / D12 / D XT 12

User Manual



Chroma-Q®
BRILLIANT SOLUTIONS

Version 1.3 March 2015 Software Version 2.0

PN: 621-0502

Warranty Statement

Chroma-Q warrants to the original purchaser, with proof of purchase, that its delivered products shall be free from defects in material and workmanship under normal use for a period of 12 months from date of shipment.

Chroma-Q will repair, or at its option, provide an equivalent item or replace, the defective product during the stated warranty period. This warranty applies only to the repair or replacement of the product and only when the product is properly handled, installed and maintained according to Chroma-Q instructions. This warranty excludes defects resulting from improper handling, storage, installation, acts of God, fire, vandalism or civil disturbances. Purchaser must notify Chroma-Q in writing within 14 days of noticing the defect. This warranty excludes field labour or service charges related to the repair or replacement of the product.

The warranty contained herein shall not extend to any finished goods or spare parts from which any serial number has been removed or which have been damaged or rendered defective (a) as a result of normal wear and tear, wilful or accidental damage, negligence, misuse or abuse; (b) due to water or moisture, lightning, windstorm, abnormal voltage, harmonic distortion, dust, dirt, corrosion or other external causes; (c) by operation outside the specifications contained in the user documentation; (d) by the use of spare parts not manufactured or sold by Chroma-Q or by the connection or integration of other equipment or software not approved by Chroma-Q unless the Customer provides acceptable proof to Chroma-Q that the defect or damage was not caused by the above; (e) by modification, repair or service by anyone other than Chroma-Q, who has not applied for and been approved by Chroma-Q to do such modification, repair or service unless the Customer provides acceptable proof to Chroma-Q that the defect or damage was not caused by the above; (f) due to procedures, deviating from procedures specified by Chroma-Q or (g) due to failure to store, install, test, commission, maintain, operate or use finished goods and spare parts in a safe and reasonable manner and in accordance with Chroma-Q's instructions (h) by repair or replacement of engines without factory training.

The warranty contained herein shall not apply to finished goods or spare parts which are sold "as is", as "second-hand", as used", as "demo" or under similar qualifications or to Consumables ("Consumables" is defined as any part(s) of goods or part(s) for use with goods, which part(s) of goods or part(s) for use with goods are consumed during the operation of the goods and which part(s) of goods or part(s) for use with goods require replacement from time to time by a user such as, but not limited to, light bulbs).

The warranty contained herein shall not apply, unless the total purchase price for the defective finished goods or spare parts has been paid by the due date for payment.

The warranty contained herein applies only to the original purchaser and are not assignable or transferable to any subsequent purchaser or end-user.

This warranty is subject to the shipment of the goods, within the warranty period, to the Chroma-Q warranty returns department, by the purchaser, at the purchasers expense. If no fault is found, Chroma-Q will charge the purchaser for the subsequent return of the goods.

Chroma-Q reserves the right to change the warranty period without prior notice and without incurring obligation and expressly disclaims all warranties not stated in this limited warranty.

Disclaimer

The information contained herein is offered in good faith and is believed to be accurate. However, because conditions and methods of use of our products are beyond our control, this information should not be used in substitution for customer's tests to ensure that Chroma-Q products are safe, effective, and fully satisfactory for the intended end use. Suggestions of use shall not be taken as inducements to infringe any patent. Chroma-Q sole warranty is that the product will meet the sales specifications in effect at the time of shipment. Your exclusive remedy for breach of such warranty is limited to refund of purchase price or replacement of any product shown to be other than as warranted.

Chroma-Q reserves the right to change or make alteration to devices and their functionality without notice due to our on going research and development.

The Chroma-Q Studio Force V 12 / T 12 / D 12 / D XT 12 range has been designed specifically for the lighting industry. Regular maintenance should be performed to ensure that the products perform well in the entertainment environment.

If you experience any difficulties with any Chroma-Q products please contact your selling dealer. If your selling dealer is unable to help please contact support@chroma-q.com. If the selling dealer is unable to satisfy your servicing needs, please contact the following, for full factory service:

Outside North America:	North America:
Tel: +44 (0)1494 446000	Tel: 416-255-9494
Fax: +44 (0)1494 461024	Fax: 416-255-3514
support@chroma-q.com	support@chroma-q.com

For further information please visit the Chroma-Q website at www.chroma-q.com.

Chroma-Q and Studio Force are trademarks, for more information on this visit www.chroma-q.com/trademarks.

The rights and ownership of all trademarks are recognised.

Important Notice:

As per the requirements in the Occupational Safety and Health Administration standards for product approval, please refer to the OSHA web pages <http://www.osha.gov/dts/otpca/nrtl/> for information on the list of Nationally Recognized Testing Laboratories (NRTLs) and the scope of recognition.

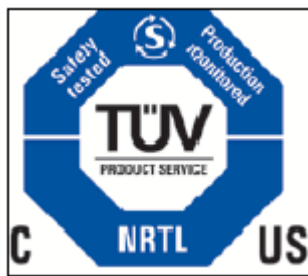

Table of Contents

1.	Product overview	3
2.	Operation	5
2.1	Unpacking the Units.....	5
2.2	Cabling	5
2.3	Mounting	5
2.5	Chevrons.....	6
2.6	Control	6
2.7	DMX Protocol – Studio Force D 12 & D XT 12.....	10
2.8	DMX Protocol – Studio Force T 12.....	11
2.9	DMX Protocol – Studio Force V 12.....	12
2.10	Thermal Performance	14
3.	Troubleshooting	15
4.	Specification	15
4.1	Technical Specifications	16
4.2	Drawings – Dimensions	17
4.3	Accessories.....	17
5.	Maintenance	17

1. Product overview

The Chroma-Q Studio Force™ 12 LED fixtures range features a choice of 6,100K CCT, daylight white (Studio Force D 12 & D XT 12), 3,000K CCT, tungsten white (Studio Force T 12) and 3,000K – 6,100K CCT, variable white (Studio Force V 12) models – the latter featuring 3200°K and 5600°K laboratory calibrated presets.

Utilising the same core technologies as the innovative Chroma-Q Color Force™ range, both models offer at least twice the light output of their RGBA colour variants.

The units provide extreme outputs of 6,000 lumens (Studio Force D 12) / 15,000 lumens (Studio Force D XT 12) / 5,000 lumens (Studio Force T 12) / 5,300 lumens (Studio Force V 12) for evenly washing large areas, complemented by smooth, theatrical grade dimming.

The Studio Force range is specifically designed for TV, film, touring, exhibitions, corporate events and theatre lighting applications.

At only 300mm / 1ft long, the fixtures are ideal for floor, wall or truss mounting. The units can also be used to extend Studio Force LED batten installations.

Optional accessories include cyc and border light lens, lightbank kit⁺, egg crate louver, top hat, half top hat, barn door, spigot adaptor and diffuser box attachment accessories.

Each model utilises two light engines featuring 24 high powered LEDs per engine and a total of 48 LEDs per fixture. The Studio Force D 12 features 24 cold white LEDs per engine, the Studio Force D XT 12 features 24 cold white high output LEDs per engine, the Studio Force T 12 features 24 warm white LEDs per engine and the Studio Force V 12 features 12 cold white and 12 warm white LEDs per engine.

Each model is equipped with a built-in power supply and can operate as a standalone unit or be remotely controlled through the ANSI E1.11 USITT DMX 512-A protocol. The control options incorporate a choice of multiple channel intensity control, effects and a dynamic Variable Effects Engine integrated in the software, which gives the user full control of the effects combination.

The product's robust anodised aluminum extruded construction houses a discreet cable management system. Additional protection is built around the lenses for a truly road proof fixture



⁺The Lightbank Kit consists of the Lightbank Adaptor (Speedring) and Lightbank. Both items can also be purchased separately. Fixture not included.

Note: HANDHELD COLOUR METERS

Handheld Colour Meters provide a very limited measuring range for LED fixtures, which results in inconsistent and unreliable

data.

All photometric values listed in this document are based on testing and measurements conducted by certified independent laboratories with reference to the IES standards.

2. Operation

2.1 Unpacking the Units

The Studio Force V 12 / T 12 / D 12 / D XT 12 package includes 1 unit Studio Force 12 fixture, power connector (EU)/power cord (US) and a Quick Start Guide. We recommend that you keep the original packaging in case the item needs to be returned.

2.2 Cabling

The Studio Force V 12 / T 12 / D 12 / D XT 12 utilise PowerCon connectors for power input and through. The DMX control data input and through connections from an external control console are via two XLR 5-pin connectors. The chassis are ground bonded.

Note: The maximum number of Studio Force V 12 / T 12 / D 12 / D XT 12 fixtures running off a single power input cable is 10 at 120V AC or 20 at 240V AC. Please refer to ANSI and AWG standards for the maximum data and power cable lengths.

XLR 5-pin Cable:

Pin#	Function
1	Ground (Screen)
2	Data Minus
3	Data Plus
4	Spare Data Minus
5	Spare Data Plus

Power Cable:

International Colour Code	North American Colour Code	Connections	
Green and Yellow	Green	Earth (E)	Ground (Green)
Blue	White	Neutral (N)	Neutral (Silver)
Brown	Black	Live (L)	Hot (Gold)

Important Notice: The use of an opto-splitter for DMX signal distribution is highly recommended when several fixture units are not plugged into the same power source.

2.3 Mounting

The Studio Force V 12 / T 12 / D 12 / D XT 12 fixtures are equipped with built-in mounting yokes for floor, wall and truss mounting applications. The yoke assembly features a hidden quick release fixing for fast and easy tilt adjustment.

Note: Secure the fixture with a safety bond. A provision for a fixing hold is built into the yoke.

2.4 Optical Accessories

Slide-in optical accessories are available to adjust the beam angle of the Studio Force V 12 / T 12 / D 12 / D XT 12 fixtures to suit a wide range of applications. Two accessory slots and a swivel plate are included at the front and side of the fixture to hold and lock these slide-in accessories: cyc and border light lens, lightbank kit, egg crate louver, top hat, half top hat, barn door and diffuser box attachment accessories.

2.5 Chevrons

The Studio Force V 12 / T 12 / D 12 / D XT 12 fixtures have the 'chevron' markings stamped on both ends and printed at the rear enclosure to indicate the side of the fixture that should be adjacent to the wall or cyclorama.

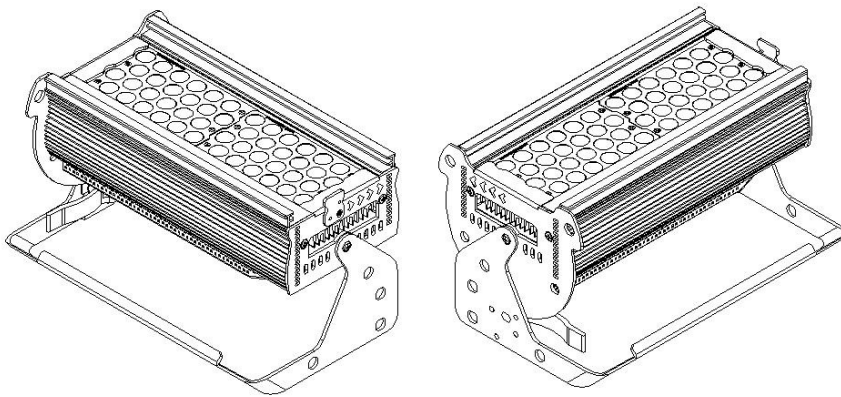

2.6 Control

Studio Force V 12 / T 12 / D 12 / D XT 12 fixtures can operate as a standalone unit or be controlled remotely via ANSI E1.11 USITT DMX512-A protocol. The control functions can be accessed through the LCD display at the rear of the fixture with 4 push buttons.

Push button operation:



Control	Function
Exit	Back to previous menu
Up Arrow	Increases (+) the mode level or value
Down Arrow	Decreases (-) the mode level or value
Back Arrow	(Enter) Stores the menu choice

Power-Up Display:

On power-up and home position, the display shows the model name, software version, the DMX address, current assigned mode and the number of assigned channels.

Display Mode:

The LCD is backlit when you access the menus. This will turn off when left undisturbed for 5 seconds.

Control Modes:

Grouping - The Studio Force V 12 / T 12 / D 12 / D XT 12 consist of 2 LED engines with 24 white LEDs each. The two engines can be controlled as a one group "All" or as two separate groups "Duo".

Studio Force D 12, D XT 12 & T 12:

8 channels (Dim8x)	1 control channel directly affecting the intensity of 6 LEDs per engine.
2 channels (FxDim)	1 control channel directly affecting the intensity of all the LEDs and 1 control channel for intensity effects.
2 channels (Dim2x)	1 control channel directly affecting the intensity of 24 LEDs per engine.
1 channel (Dim1x)	1 control channel directly affecting the intensity of all the LEDs.
1 channel (Look Select)	1 control channel directly selecting scenes from the look store.

Studio Force V 12:

8 channels (WWWW)	1 control channel directly affecting the intensity of 6 LEDs per engine.
3 channels (sWWCW)	1 control channel for intensity effects, the 2 nd control channel directly affecting the intensity of all warm white LEDs and the 3 rd channel directly affecting the intensity of all cold white LEDs.
2 channels (WW/CW)	1 control channel directly affecting the intensity of all warm white LEDs and the 2 nd control channel directly affecting the intensity of all cold white LEDs.
2 channels (CTI)	1 control channel for Colour Temperature adjustment and the 2 nd control channel for Intensity level.
1 channel (Look Select)	1 control channel directly selecting scenes from the look store.

Other Control Modes (Both Models):

Internal FX engine: integrated in the software is an internal Fx engine with variable parameters to create an unlimited amount of unique lighting effects.

Master Standalone – assigns the unit to be the Master unit where standalone control options are set.

Slave Standalone – assigns the unit to be the Slave unit and follows the control options assigned to the Master unit.

Manual – gives manual control for the Intensity level (Studio Force D 12, D XT 12 & T 12), and Intensity and Colour Temperature (Studio Force V 12)

Control Menu

Use the push buttons (up/down arrows) to scroll through the control menu options:

→ Home / DMX Address

To set the DMX start address, press Enter, press Up/Down buttons to adjust DMX start address, press Enter for 2 seconds to save settings, the display goes back to Home.



Control Mode

The Studio Force V 12 / T 12 / D 12 / D XT 12 can be set to operate in 5 DMX controlled modes and 3 standalone modes. 2 grouping options are available cell-grouped (“Duo”) and all-grouped (“All”). Refer to the list below for details.

Press the Up/Down buttons to access the “Control Mode”, press Up/Down to select the mode and press Enter for 2 seconds to save the settings.

Studio Force D 12, D XT 12 & T 12

Control Mode - Software Version 2.0

Mode	Name	Group	Ch	Description
1	Dim8x	Duo	8	WWWW + WWWW
2	FxDim	All	2	1 intensity Fx + All
3	Dim2x	Duo	2	2 x W
4	Dim1x	All	1	All
11	Look Sel		1	Look Select
12	Mastr StndAlon			Standalone Master
13	Slave StndAlon			Standalone Master
	Manual			Manual

Manual:

In this mode, the intensity level “Intensity” can be set and adjusted in standalone operation. From the main menu, press Up/Down to access “Control Mode”, press Up/Down to select “Manual”, and then press Enter for 2 seconds to save the setting. Press Exit and the display will show “Manual Control” and the intensity level “00% Intensity”. To adjust the levels press Enter once “00%” level will flash. Use the Up/Down buttons to adjust the value and press Enter for 2 seconds to save the settings.

Studio Force V 12

Control Mode - Software Version 2.0

Mode	Name	Group	Ch	Description
1	WWWW	Duo	8	WWWW + WWWW
2	sWWCW	All	3	1 Intensity Fx + WW + CW
3	WW/CW	All	2	WW + CW
4	CTI	All	2	1 Colour Temperature + Intensity
11	Look Sel		1	Look Select
12	Mastr StndAlon			Standalone Master
13	Slave StndAlon			Standalone Master
	Manual			Manual

Manual:

In this mode, the intensity level “Int” and colour temperature “CT” can be set and adjusted in standalone operation. From the main menu, press Up/Down to access “Control Mode”, press Up/Down to select “Manual”, and then press Enter for 2 seconds to save the setting. Press Exit and the display will show “Manual Control” – the level of colour temperature “CT 00%” and the intensity level “Int 00%”. To adjust the levels press Enter once and the CT level will flash. Use the Up/Down buttons to adjust the value and press Enter again once and the “Int” level will flash. Use the Up/Down buttons to adjust the value and press Enter for 2 seconds to save the settings.

→ When DMX is Lost

If DMX is not detected various output options can be selected:

Press Up/Down to access “When DMX is Lost”, press Enter, press Up/Down buttons to select the options , press Enter for 2 seconds to save.

‘Off’ - will snap to off

‘Hold’ - will hold the last valid DMX state

‘Look 1-31’ will snap to the Look of your choice

→ Look Store

The Studio Force V 12 / T 12 / D 12 / D XT 12 can record 31 Looks for standalone operation. In the Studio Force V / D / D XT fixtures, pre-programmed Looks are stored in 1-23 and only Look 1 is pre-programmed in the Studio Force T fixture. (*Note: Only a selection of pre-programmed Looks is applicable to the Studio Force D, D XT and T fixtures.)

To replay a Look in standalone operation, press Up/Down buttons to access “Look Store”, press Enter, press Up/Down buttons to select the desired Look and press Enter for 2 seconds to save settings.

To replay a Look with a DMX console, press Up/Down buttons to access Control Mode 11 and press Enter for 2 seconds. Use the DMX console with the assigned channel to playback the various looks stored. (1-31 looks in 1 single channel)

(Note: DMX has priority over internal Looks)

Looks can be recorded to the internal flash memory by users and will be preserved on power down. However, looks will be returned to default setting if Reset is performed. There are two ways to record a look:

Simple, with DMX console

Set the Studio Force V 12 / T 12 / D 12 / D XT 12 to the desired Control Mode. Use a DMX console to adjust channel levels and create the desired look or effect. Press Up/Down buttons to the “Look Store” and press Enter, press Up/Down buttons to the desired Look number and press Enter. Press Enter again for 2 seconds to save Look.

Advanced, standalone (DMX is unplugged)

Press Up/Down buttons to access “Look Store”, and press Enter, press Up/Down button to the desired Look and press Enter to access the memory data. The data is presented as two numbers separated by a letter “c”. The number to the left of the “c” is the channel number and to the right is the channel level. Pressing Up/Down up to the far end will show the Mode at which the selected Look was programmed.

To edit the Mode of a selected Look:

Press Up/Down buttons to access “Look Store” and press Enter, press Up/Down to the desired Look and press Enter to access the memory data. Press Up/Down buttons up to the far end until Mode number is shown and press Enter. Press Up/Down buttons to adjust the Mode number. Press Enter to toggle back to the channel numbers.

To edit the channel numbers and levels of a selected Look:

Press Up/Down buttons to access “Look Store” and press Enter, press Up/Down to the desired Look and press Enter to access the memory data. Press Up/Down buttons and select the channel number. To edit the channel level, press Enter and use the Up/Down buttons to adjust the level (shown as 0-255). Press Enter to toggle back to the channel number. When the desired effect is created press Enter for 2 seconds to save the edited Look.

→ Technical

In this mode, frequency settings of the unit can be changed; and pre-programmed engines can be uploaded.

Press Up/Down to access "Technical", press Up/Down to select either "Frequency" or "Upload Engines".

Frequency:

The Studio Force V 12 / T 12 / D 12 / D XT 12 has four frequency settings available - 600, 1200, 2400, 4800. This allows for the LED scan rate to be synchronised with the video camera and avoid a flickering effect. Press the Up/Down buttons to select the desired frequency, press Enter for 2 seconds to save settings.

Upload Engines:

Pre-programmed engines can be uploaded to the Studio Force V 12 / T 12 / D 12 / D XT 12 from the Chroma-Q Uploader:

1. Press Enter, Up/Down buttons to select "Upload Engines" then press Enter, and the display will show "Ready":
2. Connect an XLR 5-pin cable from the Uploader to the unit.
3. Power-up the Uploader - display will show the file name, and "Ready".
4. Press the "GO" button once to execute the uploading - red indicator light on the "GO" button will blink.
5. The Uploader display will show a simulated arrow moving from left to right indicating the uploading process.
6. All the white LEDs of the unit will light up (low intensity) to indicate completion of a successful Upload and the Uploader display will show "DONE".
7. Power-cycle the unit.

(See Quick Start Guide of the Chroma-Q Uploader)

➔ Output Setting

This menu applies to the Color Force 12 fixtures. The light output of the Color Force 12 fixtures can be adjusted to two levels. "Standard" is the maximum light output and "Matching CF48/72" is the light output level that matches the levels of the Color Force 72 and 48 fixtures.

Press Up/Down to access "Output Setting", then press Enter and Up/Down to select between "Standard" or Matching CF48/72".

➔ Fan Speed

The Studio Force V 12 / T 12 / D 12 / D XT 12 are built with an internal fan with four speed options to regulate noise levels and the cooling process. The internal fan is off in the "Quiet" mode. The "Studio" mode is the equivalent to low velocity for most studio application and cooler locations. "Live" mode is the equivalent to high velocity for louder/less critical applications and warmer locations. "Live with Light" mode is equivalent to the "Live" mode activating when the light is on.

Press Enter, Up/Down buttons to select "Fan Speed", then press Enter to select from either "Quiet", "Studio", "Live" or "Live with Light", and then press Enter for 2 seconds to save the settings.

➔ Reset to Default

Press Up/Down to access "Reset to Default", press Enter, display will show "reset?", press Enter for 2 seconds, display will show "resetting" and "done" when complete, and all menu items are reset to factory defaults:

DMX address = 001, Control Mode = 2, When DMX is Lost = Hold, Looks = 00,

Frequency = 600, Fan Speed = Quiet, Output Setting = Standard.

2.7 DMX Protocol – Studio Force D 12 & D XT 12

Studio Force D 12 & D XT 12 - DMX Personality Mode 1-2:

Studio Force D 12 & D XT 12	Control Mode 1 [8ch] Dim8x	Control Mode 2 [2ch] FxDim
-----------------------------	-------------------------------	-------------------------------

v2.0	Group : Duo	Group : All
Channel 1	Cold White for group 1	Intensity Effects 0 Static 1-63 Fade on, fade off. Variable, 63 fastest 64-127 Fade on, snap off. Variable, 127 fastest 128-191 Snap on, fade off. Variable, 191 fastest 192-255 Snap on, snap off (strobe). Variable, 255 fastest.
Channel 2	Cold White for group 1	Cold White for group 1
Channel 3	Cold White for group 1	
Channel 4	Cold White for group 1	
Channel 5	Cold White for group 2	
Channel 6	Cold White for group 2	
Channel 7	Cold White for group 2	
Channel 8	Cold White for group 2	
Total	8 DMX channels	2 DMX channels

Studio Force D 12 & D XT 12- DMX Personality Mode 3-4:

Studio Force D 12 & D XT 12 v2.0	Control Mode 3 [2ch] Dim2x Group: Duo	Control Mode 4 [1ch] Dim1x Group : All
Channel 1	Cold White for group 1	Cold White for group 1
Channel 2	Cold White for group 2	
Total	2 DMX channels	1 DMX channel

2.8 DMX Protocol – Studio Force T 12

Studio Force T 12 - DMX Personality Mode 1-2:

Studio Force T 12 v2.0	Control Mode 1 [8ch] Dim8x Group : Duo	Control Mode 2 [2ch] FxDim Group : All
Channel 1	Warm White for group 1	Intensity Effects 0 Static 1-63 Fade on, fade off. Variable, 63 fastest

		64-127 Fade on, snap off. Variable, 127 fastest 128-191 Snap on, fade off. Variable, 191 fastest 192-255 Snap on, snap off (strobe). Variable, 255 fastest.
Channel 2	Warm White for group 1	Warm White for group 1
Channel 3	Warm White for group 1	
Channel 4	Warm White for group 1	
Channel 5	Warm White for group 2	
Channel 6	Warm White for group 2	
Channel 7	Warm White for group 2	
Channel 8	Warm White for group 2	
Total	8 DMX channels	2 DMX channels

Studio Force T 12 - DMX Personality Mode 3-4:

Studio Force T 12 v2.0	Control Mode 3 [2ch] Dim2x Group: Duo	Control Mode 4 [1ch] Dim1x Group : All
Channel 1	Warm White for group 1	Warm White for group 1
Channel 2	Warm White for group 2	
Total	2 DMX channels	1 DMX channel

2.9 DMX Protocol – Studio Force V 12

Studio Force V 12 - DMX Personality Mode 1-2:

Studio Force V 12 v2.0	Control Mode 1 [8ch] WWWW Group : Duo	Control Mode 2 [3ch] sWWCW Group : All
Channel 1	Cold White for group 1	Intensity Effects

		0 Static 1-63 Fade on, fade off. Variable, 63 fastest 64-127 Fade on, snap off. Variable, 127 fastest 128-191 Snap on, fade off. Variable, 191 fastest 192-255 Snap on, snap off (strobe). Variable, 255 fastest.
Channel 2	Warm White for group 1	Warm White for group 1
Channel 3	Warm White for group 1	Cold White for group 2
Channel 4	Cold White for group 1	
Channel 5	Cold White for group 2	
Channel 6	Warm White for group 2	
Channel 7	Warm White for group 2	
Channel 8	Cold White for group 2	
Total	8 DMX channels	3 DMX channels

Studio Force V 12 - DMX Personality Mode 3-4:

Studio Force V 12 v2.0	Control Mode 3 [2ch] WW/CW Group: All	Control Mode 4 [2ch] CTI Group : All
Channel 1	Warm White for group 1	Colour Temperature for group 1
Channel 2	Cold White for group 1	Intensity level for group 1
Total	2 DMX channels	2 DMX channels

Studio Force V 12 - DMX Personality Mode 11:

Studio Force V 12 v2.0	Mode 11 [1ch] Look Select
---------------------------	---------------------------

Channel 1	Channel levels and the corresponding Look numbers:		
	Channel Level (%)	Look	Description
	0	OFF	
	1-2	1	Full Scroll (5 sec)
	3-5	2	Full Scroll (10 sec)
	6-9	3	Full Scroll (30 sec)
	10-11	4	Warm Colour Scroll (5 sec)
	12-15	5	Warm Colour Scroll (10 sec)
	16-19	6	Warm Colour Scroll (30 sec)
	20-22	7	Cold Colour Scroll (5 sec)
	23-25	8	Cold Colour Scroll (10 sec)
	26-27	9	Cold Colour Scroll (30 sec)
	29-32	10	
	33-35	11	
	36-38	12	
	39-42	13	
	43-45	14	
	46-48	15	
	49-51	16	
	52-54	17	
	56-58	18	
	59-61	19	
	62-64	20	
	65-68	21	
	69-71	22	3200 White
	72-74	23	5600 White
	75-78	24	
	79-81	25	
	83-85	26	
	86-88	27	
	89-91	28	
	92-94	29	
95-97	30		
98-100	31		

*Note: Not all pre-programmed Looks are applicable to the Studio Force D, D XT and T fixtures.

2.10 Thermal Performance

The Studio Force V 12 / T 12 / D 12 / D XT 12 fixture unit is equipped with an internal fan to drive the internal cooling system. If the internal temperature of the Studio Force 12 exceeds 75°C the output of the fixture is reduced for automatic protection. This happens on rare and extreme conditions when ambient temperature is over 35°C or the internal fans are blocked or damaged.

The airflow to and from the fan must not be constricted to maintain the maximum operating capacity of the Studio Force V 12 / T 12 / D 12 / D XT 12.

3. Troubleshooting

Troubleshooting is a process of elimination. First, rule out the other field factors (i.e. bad connections, faulty cables and power supplies). For technical support and/or parts, please contact your selling dealer or the offices listed in this manual.

Symptom	Possible Cause	Solution
Fixture does not respond to DMX control.	Set to wrong or different DMX address. Bad cable connecting DMX control and fixture. Bad in/through connection between adjacent fixtures.	Check DMX address and Mode settings. Check/replace DMX run from the console.
Noise from fixture unit.	Fan malfunction.	Check fan.
Low LED output.	Internal temperature is over the limit. Fan is not working.	Check "Fan Control" mode. Check fan. Check for airflow - to and from the internal fan. Check area ventilation.

4. Specification

4.1 Technical Specifications

	Studio Force D 12	Studio Force D XT 12	Studio Force T 12	Studio Force V 12
Product Code	CHSFD12NF	CHSFDXT12N	CHSFT12NF	CHSFV12NF
Net Dimensions**	335mm x 190mm x 218mm / 13.2" x 7.5" x 8.6"			
Net Weight	4kgs / 9lbs			
Power Supply	Built-in			
Power Input Rating	100-240V AC, 50-60 Hz, 160VA			
Power Factor	0.9			
Power Consumption	150W @ 120/240V AC			
Typical Power & Current	Measurements done with all LEDs at max. intensity. Measurements made at nominal voltage. Allow for a deviation of +/- 10%.			
Power Connector In/Out	PowerCon			
Data Connectors In/Out	XLR 5-pin			
Control Protocol	ANSI E1.11 USITT DMX 512-A			
Cooling System	Forced – 1 x fan			
Construction	Black anodised aluminium extrusion			
Colour	Black			
Built-In Hardware	Quick release lever for tilt adjustment			
IP Rating	IP20			
Approvals	CISPR 22 :2006/EN55022 :2006 & CISPR 24 :1997/EN55024 :1998, ICES-003 :2004 & FCC Part 15 Subpart B: 2007, CSA C22. No. 166-M1983:R2008 UL 1573:2003; UL 8750			
LED Engines	2			
LEDs Per Engine	24 Cold White	24 Cold White (High Output)	24 Warm White	12 Cold White / 12 Warm White
Total LEDs	48			
Control Modes	8 channels Dim8x 2 channels FxDim 2 channels Dim2x 1 channel Dim1x 1 channel Look Select Master Standalone Slave Standalone Manual			8 channels WWWW 3 channels WWCW 2 channels WW/CW 2 channel CTI 1 channel Look Select Master Standalone Slave Standalone Manual
Dimming Curve	Theatrical			
Variable Effects Engines	Yes			
Effects Parameters	Intensity Effects			
Hot Lumen Output	White 6,000 hot lumens	White 15,000 hot lumens	White 5,000 hot lumens	White 5,300 hot lumens @ 4,200K
Optics	Specialised close focus lens			
Beam angle	~23°	~17°	~23°	~23°
Beam Angle With Optional Cyc Optic	80 x 30° (approx.)			
Beam Angle With Optional Border Optic	60° (approx.)			
Beam distribution	Asymmetrical direct illumination			
CCT (+/- 200K)	6,100K		3,000K	3,000K – 6,100K
Colour Gamut	Performance enhanced			
CRI	≥70		≥80	
Lamp Life	L70 at 50,000 hours			
Operating temperature	0°C to 40°C			

**For exact measurements please refer to the line drawings below



4.2 Drawings – Dimensions

STUDIO FORCE V 12 STUDIO FORCE T 12 STUDIO FORCE D 12 STUDIO FORCE D XT 12

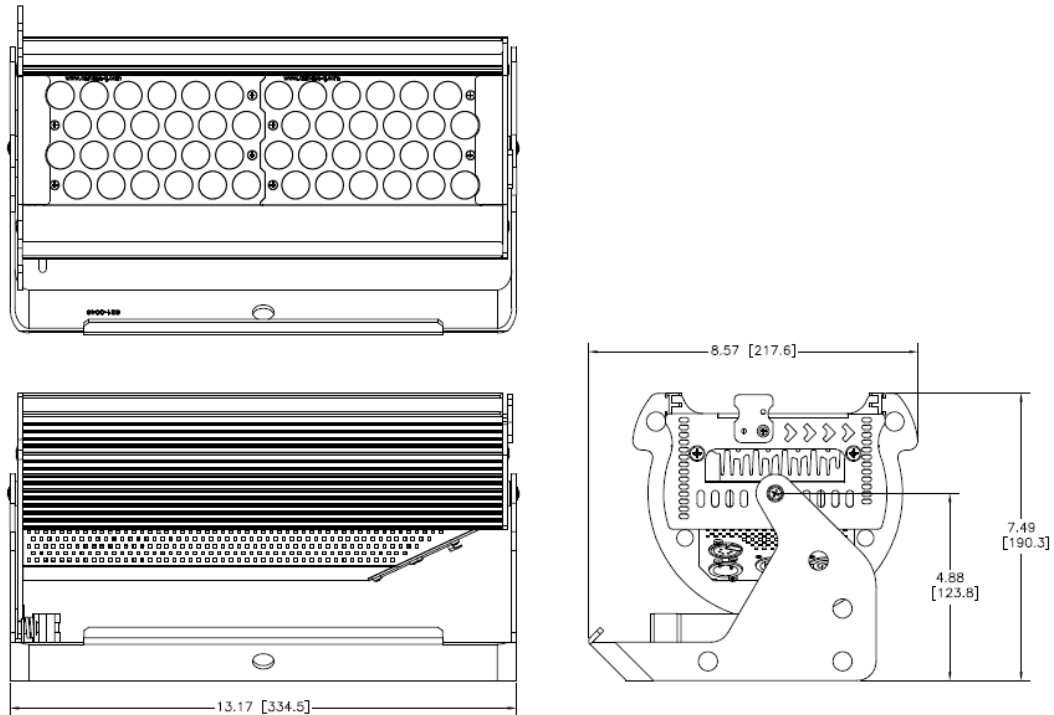

DISCLAIMER: Dimensions and illustrative drawings contained herein are accurate to the company's knowledge at the time of printing, however specifications are subject to change without notice

4.3 Accessories

CHCFCL12 – Cyc Lens For Force 12	CHCFBD12 – Barn Door For Force 12
CHCFBL12 – Border Light Lens For Force 12	CHCFDBX – Diffuser Box For Force 12
CHCFSA12 – Spigot Adaptor For Force 12	CHCFLBA12 – Lightbank Adaptor (Speedring) For Force 12
CHCFECL12 – Egg Crate Louver For Force 12	CHCFLB12 – Lightbank For Force 12
CHCFTH12 – Top Hat For Force 12	CHCFLBK-K – Lightbank Kit* For Force 12 (consists of Lightbank Adaptor (Speedring) & Lightbank)
CHCFH12 – Half Top Hat For Force 12	

* The Lightbank Kit consists of the Lightbank Adaptor (Speedring) and Lightbank. Both items can also be purchased separately. Fixture not included

5. Maintenance

With care, the Studio Force V 12 / T 12 / D 12 / D XT 12 will require little maintenance. However, as the unit is likely to be used in a stage environment we recommend periodical internal inspection and cleaning of any resulting dust and cracked oil residue.

Do not spray liquids on the front or rear panel. If the front enclosure requires cleaning, wipe with a mild detergent on a damp cloth.