



Chroma-Q®
BRILLIANT SOLUTIONS

Specification Sheet - Version: 1.2
Chroma-Q® Studio Force D XT 12™
Daylight White LED Fixture
Part No: CHSFDXT12N

DESCRIPTION

The fixture shall provide a very powerful hot lumens output of up to 15,000 lumens, for washing large areas.
The fixture shall be suitable for creating a wide range of lighting applications, including key-lighting, uplighting, backlighting and wash applications.
The fixture shall be suitable for floor, wall, stand or truss mounting.
The fixture shall provide 6,100K CCT (+/-200K) daylight white light output.
The fixture shall provide a minimum CRI of 70.
The fixture shall provide a smooth, linear dimming curve.
The fixture shall feature a built-in stand-alone mode.
The fixture shall feature a built-in power supply.
The fixture shall be manufactured from extruded material.

FEATURES

- 6,100K CCT (+/-200k) daylight white
- Extreme output – up to 15,000* lumens
- Extremely smooth, uniform wash
- Theatrical grade dimming
- Ideal for TV, film, touring, exhibitions, corporate events and theatre
- 335mm / 13.2" length ideal for floor, wall, stand or truss mounting
- Camera friendly
- PowerCon input and output for easy daisy chaining of fixtures
- Broad range of accessories available, including lightbank kit and barn door
- Flat end plates for seamless wall-washing
- Built-in power supply
- Hidden quick release fixings
- Rugged extruded aluminium body

ORDERING INFORMATION

CHSFDXT12N: Chroma-Q Studio Force D XT 12, body finished in black

ACCESSORIES

- CHCFCL12: Cyc Lens For Force 12
- CHCFBL12: Border Light Lens For Force 12
- CHCFSA12: Spigot Adaptor For Force 12
- CHCFECL12: Egg Crate Louver For Force 12
- CHCFTH12: Top Hat For Force 12
- CHCFHTH12: Half Top Hat For Force 12
- CHCFBD12: Barn Door For Force 12
- CHCFDBX: Diffuser Box For Force 12
- CHCFLBA12: Lightbank Adaptor (Speedring) For Force 12
- CHCFLB12: Lightbank For Force 12
- *CHCFLBK-K: Lightbank Kit+ For Force 12 (consists of Lightbank Adaptor (Speedring & Lightbank)

OVERALL SPECIFICATIONS

Net dimensions (without fixings):	Width: 335mm / 13.2" Height: 190mm / 7.5" Depth: 218mm / 8.6"
Net weight:	4kgs / 9lbs
Shipping dimensions:	Width: 432mm / 17" Height: 343mm / 13.5" Depth: 279mm / 11"
Shipping weight:	6kgs / 13lbs
Power supply:	Built-in
Power input rating:	100-240V AC, 50-60 Hz, 171VA
Power factor:	0.998
Control protocol:	ANSI E1.11 USITT DMX 512-A
Power consumption:	171W
Typical power & current:	Measurements done with all LEDs at max. intensity. Measurements made at nominal voltage. Allow for deviation of +/- 10%
Power connector in/out:	PowerCon
Data connector in/out:	XLR 5-pin
Cooling system:	Forced - 1 fan
Construction:	Anodised aluminium extrusion
Colour:	Black
Built in hardware:	Quick release lever for tilt adjustment
IP Rating:	IP20
Approvals CE:	CISPR 22 :2006/EN55022 :2006 & CISPR 24 :1997/ EN55024 :1998, ICES-003 :2004 & FCC Part 15 Subpart B: 2007, CSA C22. No. 166-M1983:R2008 UL 1573:2003; UL 8750
LED engines:	2
LEDs per engine:	24 Cold White
Total LEDs:	48
Control modes:	8 channels Dim8x 2 channels FxDim 2 channels Dim2x 1 channel Dim1x 1 channel Look Select Master Standalone Slave Standalone Manual Theatrical
Diming Curve:	Theatrical
Variable effects engine:	Yes
Effects parameters:	Intensity Effects
Hot Lumen output:	Up to 15,000
CRI:	≥70
Optics:	Specialised close focus lens
Beam angle:	~17°
Beam Angle With	
Beam distribution:	Symmetrical direct illumination
CCT:	6,100K (+/- 200K)
Lamp life:	L70 at 50,000 hours
Colour Gamut:	Performance enhanced



Chroma-Q®
BRILLIANT SOLUTIONS

Specification Sheet - Version: 1.2
Chroma-Q® Studio Force D XT 12™
Daylight White LED Fixture
Part No: CHSFDXT12N

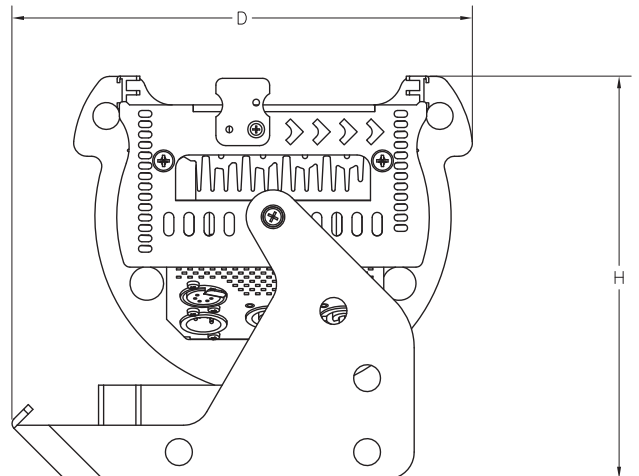
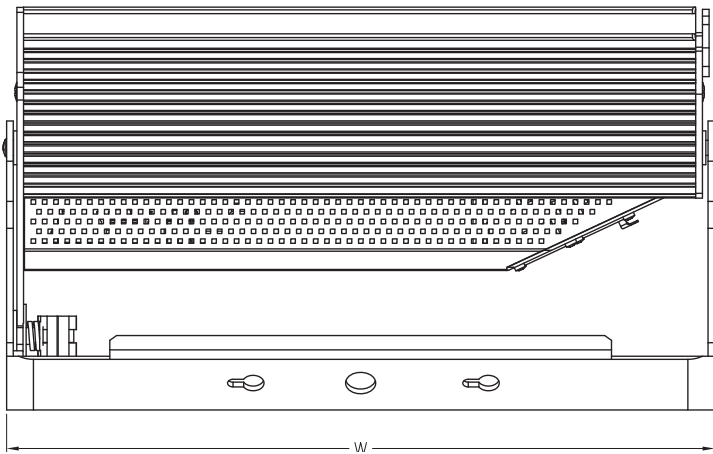
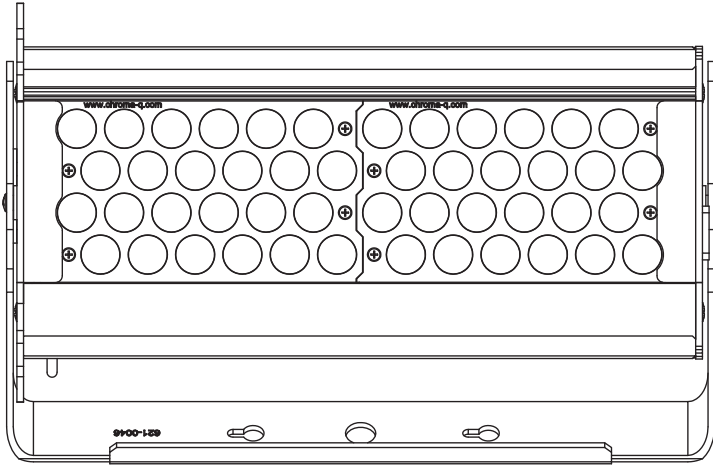

HQ, UK & International Sales
A.C. Entertainment Technologies Ltd.
Tel: +44 (0)1494 446000
Fax: +44 (0)1494 461024
sales@ac-et.com
www.ac-et.com

Northern UK Sales
A.C. Entertainment Technologies Ltd.
Tel: 0113 255 7666
Fax: 0113 255 7676
acnorth@ac-et.com
www.ac-et.com

North American Sales
A.C. Lighting Inc.
Tel: 416-255-9494
Fax: 416-255-3514
northamerica@aclighting.com
www.aclighting.com

Asian Sales
A.C. Lighting Asia KK
Tel: +81 03-6907-1758
Fax: +81 03-6907-1589
sales@aclighting.jp
www.aclighting.jp

Chroma-Q and all associated product names are recognised trademarks, for more information visit www.chroma-q.com/trademarks. The rights and ownership of all trademarks are recognised. The information contained herein is correct at the time of printing, however as we are constantly refining our product range we reserve the right to change the specification without notice. E&OE.