

# Chroma-Q<sup>®</sup> Space Force<sup>™</sup>

User Manual



**Chroma-Q<sup>®</sup>**  
BRILLIANT SOLUTIONS

Version 1.2 March 2016, Software Version 1.4

Model: 650-1000 & 650-1500

## Warranty Statement

Chroma-Q warrants to the original purchaser, with proof of purchase, that its delivered products shall be free from defects in material and workmanship under normal use for a period of 12 months from date of shipment.

Chroma-Q will repair, or at its option, provide an equivalent item or replace, the defective product during the stated warranty period. This warranty applies only to the repair or replacement of the product and only when the product is properly handled, installed and maintained according to Chroma-Q instructions. This warranty excludes defects resulting from improper handling, storage, installation, acts of God, fire, vandalism or civil disturbances. Purchaser must notify Chroma-Q in writing within 14 days of noticing the defect. This warranty excludes field labour or service charges related to the repair or replacement of the product.

The warranty contained herein shall not extend to any finished goods or spare parts from which any serial number has been removed or which have been damaged or rendered defective (a) as a result of normal wear and tear, wilful or accidental damage, negligence, misuse or abuse; (b) due to water or moisture, lightning, windstorm, abnormal voltage, harmonic distortion, dust, dirt, corrosion or other external causes; (c) by operation outside the specifications contained in the user documentation; (d) by the use of spare parts not manufactured or sold by Chroma-Q or by the connection or integration of other equipment or software not approved by Chroma-Q unless the Customer provides acceptable proof to Chroma-Q that the defect or damage was not caused by the above; (e) by modification, repair or service by anyone other than Chroma-Q, who has not applied for and been approved by Chroma-Q to do such modification, repair or service unless the Customer provides acceptable proof to Chroma-Q that the defect or damage was not caused by the above; (f) due to procedures, deviating from procedures specified by Chroma-Q or (g) due to failure to store, install, test, commission, maintain, operate or use finished goods and spare parts in a safe and reasonable manner and in accordance with Chroma-Q's instructions (h) by repair or replacement of engines without factory training.

The warranty contained herein shall not apply to finished goods or spare parts which are sold "as is", as "second-hand", as used", as "demo" or under similar qualifications or to Consumables ("Consumables" is defined as any part(s) of goods or part(s) for use with goods, which part(s) of goods or part(s) for use with goods are consumed during the operation of the goods and which part(s) of goods or part(s) for use with goods require replacement from time to time by a user such as, but not limited to, light bulbs).

The warranty contained herein shall not apply, unless the total purchase price for the defective finished goods or spare parts has been paid by the due date for payment.

The warranty contained herein applies only to the original purchaser and are not assignable or transferable to any subsequent purchaser or end-user.

This warranty is subject to the shipment of the goods, within the warranty period, to the Chroma-Q warranty returns department, by the purchaser, at the purchaser's expense. If no fault is found, Chroma-Q will charge the purchaser for the subsequent return of the goods.

Chroma-Q reserves the right to change the warranty period without prior notice and without incurring obligation and expressly disclaims all warranties not stated in this limited warranty.

## Disclaimer

The information contained herein is offered in good faith and is believed to be accurate. However, because conditions and methods of use of our products are beyond our control, this information should not be used in substitution for customer's tests to ensure that Chroma-Q products are safe, effective, and fully satisfactory for the intended end use. Suggestions of use shall not be taken as inducements to infringe any patent. Chroma-Q sole warranty is that the product will meet the sales specifications in effect at the time of shipment. Your exclusive remedy for breach of such warranty is limited to refund of purchase price or replacement of any product shown to be other than as warranted.

Chroma-Q reserves the right to change or make alteration to devices and their functionality without notice due to our on going research and development.

The Chroma-Q Space Force range has been designed specifically for the lighting industry. Regular maintenance should be performed to ensure that the products perform well in the entertainment environment.

If you experience any difficulties with any Chroma-Q products please contact your selling dealer. If your selling dealer is unable to help please contact [support@chroma-q.com](mailto:support@chroma-q.com). If the selling dealer is unable to satisfy your servicing needs, please contact the following, for full factory service:

**Outside North America:**

Tel: +44 (0)1494 446000

Fax: +44 (0)1494 461024

[support@chroma-q.com](mailto:support@chroma-q.com)

**North America:**

Tel: 416-255-9494

Fax: 416-255-3514

[support@chroma-q.com](mailto:support@chroma-q.com)

For further information please visit the Chroma-Q website at [www.chroma-q.com](http://www.chroma-q.com).

Chroma-Q and Space Force are trademarks, for more information on this visit [www.chroma-q.com/trademarks](http://www.chroma-q.com/trademarks).

The rights and ownership of all trademarks are recognised.

**Important Notice:**

As per the requirements in the Occupational Safety and Health Administration standards for product approval, please refer to the OSHA web pages <http://www.osha.gov/dts/otpc/nrtl/> for information on the list of Nationally Recognized Testing Laboratories (NRTLs) and the scope of recognition.

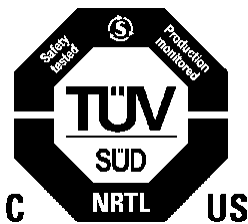

# Table of Contents

<b>1. Product overview</b> .....	<b>4</b>
<b>2. Operation</b> .....	<b>5</b>
2.1 Unpacking the Units.....	5
2.2 Cabling .....	5
2.3 Mounting .....	6
2.4 Control .....	6
2.5 Thermal Performance .....	12
<b>3. Troubleshooting</b> .....	<b>13</b>
<b>4. Specification</b> .....	<b>14</b>
4.1 Technical Specification .....	14
4.2 Drawings – Dimensions .....	15
<b>5. Accessories</b> .....	<b>16</b>
<b>6. Maintenance</b> .....	<b>16</b>

# 1. Product overview

The new Chroma-Q® Space Force™ is a cutting-edge variable white LED Space Light fixture that is a true replacement for a conventional space light and soft light source commonly used in Film and TV studios around the world. It features extensive RDM functionality through wired or the optional wireless Lumen Radio CRMX connections. Hanging options include a standard bridle, optional yoke and a low-profile hanging bracket.

## Smooth, Soft Output

With a high degree of efficiency, the fixture is natively single source, removing the need for skirts or silks to diffuse the light. Designed for lighting stages and studios, the Space Force provides a high-quality, variable CCT soft white light.

As a result of its low profile, lightweight and skirt-free design, the Space Force is quick and easy to set up at any height.

Taking advantage of Chroma-Q's extensive experience and impressive track record in developing LED lighting solutions, the Space Force utilises the very latest technologies, high quality components and manufacturing techniques in order to deliver a reliable, premium performance light source.

## A White Light for Every Application

The Chroma-Q Space Force is available as a variable white model 2,800K – 6,300K. Every unit is factory calibrated, to ensure consistent output and colour temperature.

## Energy-Efficient

The Chroma-Q Space Force uses a fraction of the power required by conventional fixtures, while delivering all of the performance you require. Not only is the power consumption lower, so too is the heat produced - ensuring a cooler environment and lower air conditioning costs.

## Convection Cooled

Using the same proven convection cooling technology found in other Chroma-Q LED fixtures - which eliminates the need for noisy cooling fans - the Space Force provides totally silent operation.

## Long Life

The Chroma-Q Space Force utilises LED technology to ensure consistent long life performance - removing the need for costly regular maintenance associated with conventional fixtures.



**Note: HANDHELD COLOUR METERS**

Most Handheld Color Meters provide a limited measuring range for LED fixtures, which often results in inconsistent and unreliable data.

All photometric values listed in this document are based on testing and measurements conducted by certified independent laboratories with reference to the IES standards.

## 2. Operation

### 2.1 Unpacking the Units

The package includes 1 Space Force fixture, power connector and a Quick Start Guide. We recommend that you keep the original packaging in case the item needs to be returned.

### 2.2 Cabling

The fixture uses powerCon True 1 chassis connectors for power in and through. Use the provided connector to make a power feeder cable of the desired length and input connector configuration.

The maximum number of Space Force fixtures running off a single power input cable and using the power through connector is 5 at 120V AC or 10 at 230V AC if using a 12 AWG (3.3mm<sup>2</sup>) wire. Please refer to ANSI and AWG standards for the maximum data and power cable lengths.

Power cable wire colour schemes:

EU	North American	Connections	
Green and Yellow	Green	Earth (E)	Ground (Green)
Blue	White	Neutral (N)	Neutral (Silver)
Brown	Black	Live (L)	Hot (Gold)

The fixture uses XLR 5 pin input and through chassis connectors for ANSI E1.20 - 2010 RDM and USITT DMX512-A control. The XLR chassis' are ground bonded.

XLR 5-pin Cable:

Pin#	Function
1	Common (Screen)
2	Data Minus
3	Data Plus
4	Spare Data Minus
5	Spare Data Plus

**Important Notice:** The use of an opto-splitter for DMX signal distribution is highly recommended when several fixture units are not plugged into the same power source.

## 2.3 Mounting

The fixture is equipped with dual purpose brackets for stacking and hanging applications. Standard and low profile yokes are available as optional accessory items.

Secure the fixture with a safety bond. A provision for a fixing hold is built into the fixture.

## 2.4 Control

The Space Force can be controlled through:

Manual Operation	The control panel at the rear of the fixture consists of the LEFT-HAND and RIGHT-HAND KNOBS and an LCD display
Input Cable	ANSI E1.20 - 2010 RDM-Remote Device Management over USITT DMX512-A control from an external console through an XLR-5 pin cable
INPUT RF	ANSI E1.20 - 2010 RDM-Remote Device Management over USITT DMX512-A control from an external console through a wireless connection

The fixture can operate as a standalone unit in manual control operation or be controlled remotely via the USITT DMX512 protocol. The control panel at the rear of the fixture consists of an LCD display, 2 rotary control knobs and 5 control buttons. The LCD display is backlit when you access the menus and turns off when left undisturbed for 5 seconds. The fixture can be remotely configured via ANSI E1.20-2010 RDM – Remote Device Management.

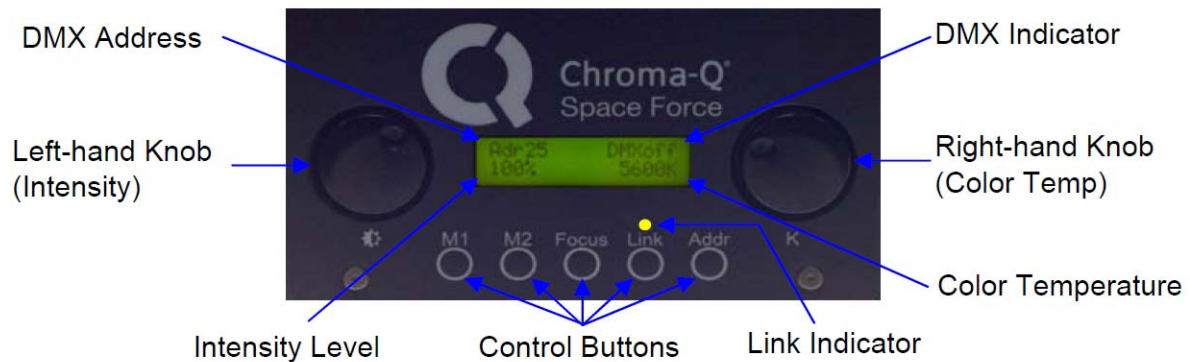

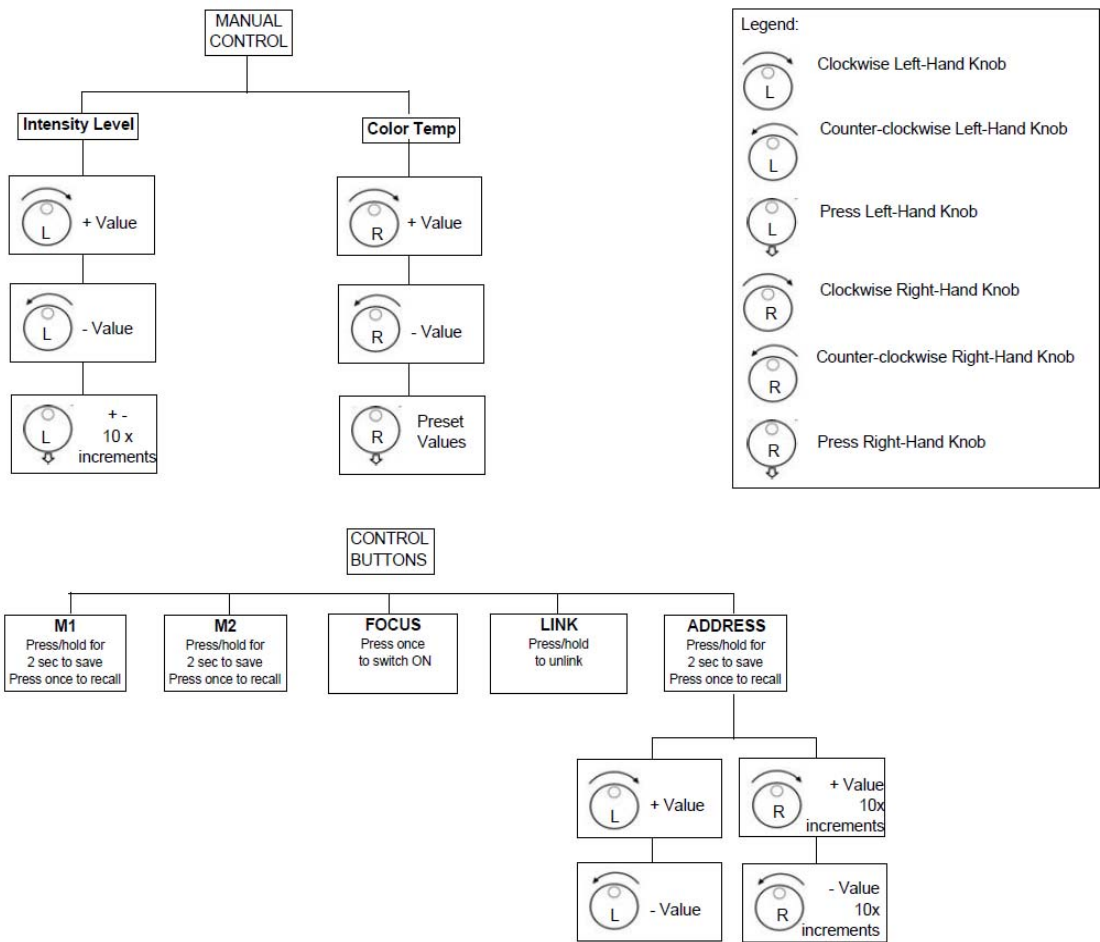

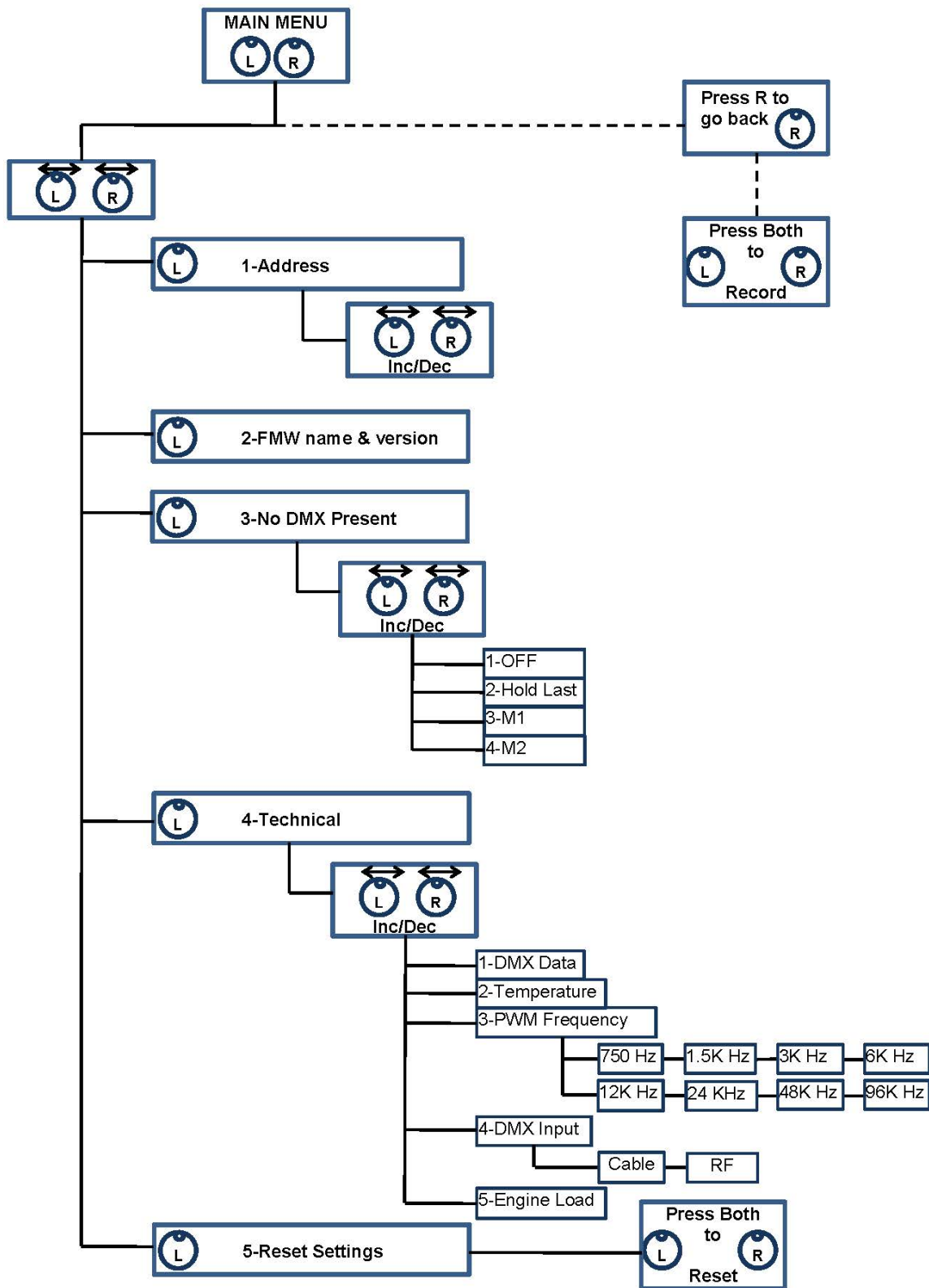



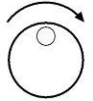
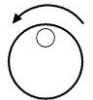

## Manual Control in Standalone Operation:

LEFT-HAND KNOB sets the Intensity Level Output

	Rotate the Left-hand Knob clockwise to increase the Intensity Level from 0 – 100%
	Rotate the Left-hand Knob counter-clockwise to decrease the Intensity Level from 100 - 0%
	Press the Left-hand Knob to set the Intensity Level from 100% - 0% in increments of 10%.

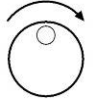
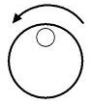
RIGHT-HAND KNOB sets the Color Temperature

	Rotate the Right-hand Knob clockwise to increase the Color Temperature value from 2700 – 6700K
	Rotate the Right-hand Knob counter-clockwise to decrease the Color Temperature value from 6700 – 2700K
	Press the Right-hand Knob to set the Color Temperature preset values: 6700K, 6500K, 5600K, 4300K, 3200K, 3000K, 2700K

## Control Buttons

<b>M1</b>	Stores a look, and recalls the saved look
	To save a look in M1, <ol style="list-style-type: none"> <li>In standalone or DMX operation, create a look</li> <li>On the control panel, press and hold M1 until “SAVED” appears on the display</li> </ol> To recall/playback a saved look in M1, <ol style="list-style-type: none"> <li>On the control panel, press M1 once</li> <li>The unit goes to the saved look in M1</li> </ol>
<b>M2</b>	Stores a look, and recalls the saved look
	To save a look in M2, <ol style="list-style-type: none"> <li>In standalone or DMX operation, create a look</li> <li>On the control panel, press and hold M2 until “SAVED” appears on the display</li> </ol> To recall/playback a saved look in M2, <ol style="list-style-type: none"> <li>On the control panel, press M2 once</li> <li>The unit goes to the saved look in M2</li> </ol>
<b>Focus</b>	Switches the fixture ON to a preset output level for 30 seconds for a quick focus check or manual re-focus
	To switch Focus on, <ol style="list-style-type: none"> <li>Press Focus once</li> <li>The preset output level switches on</li> </ol>
<b>Link</b>	Unlinks from the previous wireless connections. Go to the section on Remote Wireless DMX Operation.
	The Link Indicator light flashes slowly when a previous wireless link is active. To unlink, <ol style="list-style-type: none"> <li>Press and hold Link for 2 – 5 seconds until the flashing light is off</li> </ol>
<b>Addr</b>	Sets the DMX start address (see section on Remote DMX Operation)

## Remote DMX Operation:

To set the DMX Start Address from the control button,

1. On the Control Panel, press the **Addr** button once, “Adr” on the top left of the display flashes
2. Use either the Left-hand and Right-hand Knobs to set the DMX start address,

### LEFT-HAND KNOB:

- Rotate the Left-hand Knob clockwise to increase the value from 1 to 512 in increments of 1
- Rotate the Left-hand Knob counter-clockwise to decrease the value in increments of 1

### RIGHT-HAND KNOB:

- Rotate the Right-hand Knob clockwise to increase the value from 1 to 512 in increments of 10
- Rotate the Right-hand Knob counter-clockwise to decrease the value in increments of 10

3. Press and hold the **Addr** button for 2 seconds to save the new DMX setting, “Done” and “SAVED” appears on the display.

To set the DMX Start Address from the Main Menu, see the following section Main Menu.

DMX Footprint: 2 channels

- 1<sup>st</sup> DMX Channel controls the Intensity Level adjustment
- 2<sup>nd</sup> DMX Channel controls the Color Temperature adjustment

## Remote Wireless DMX:

To activate a wireless link,

1. Unlink the fixture – see instructions on page 9
2. Enable the INPUT RF from the Technical Menu
3. From the external transmitter, activate a link
4. The Link Indicator flashes fast to indicate the link in progress
5. The Link Indicator flashes slowly to indicate the link complete and active

## RDM Compliant:

The Space Force is an ANSI E1.20 - 2010 RDM-Remote Device Management compliant device which allows bi-directional control configuration, status monitoring and management through the wired and wireless DMX connection. The following functions are implemented: DEVICE\_INFO, DEVICE\_MODEL\_DESCRIPTION, MANUFACTURER\_LABEL, DEVICE\_LABEL, SOFTWARE\_VERSION\_LABEL, DMX\_PERSONALITY, DMX\_START\_ADDRESS, SENSOR\_DEFINITION, SENSOR\_VALUE, DEVICE\_HOURS, DEVICE\_POWER\_CYCLES, IDENTIFY\_DEVICE, RESET\_DEVICE

## Main Menu

FUNCTION	ACTION
To access the Main Menu in the LCD Display	Press both LEFT-HAND and RIGHT-HAND KNOBS at the same time
To enter/select the menu	Press the LEFT-HAND KNOB once
To scroll through the menu items	Rotate the LEFT-HAND KNOB clockwise/counter-clockwise
To exit back to the previous menu or the main display	Press the RIGHT-HAND KNOB once
To save the selected menu item	Press and hold the LEFT-HAND and RIGHT-HAND KNOBS for 2 seconds and the display shows "SAVED"

⇒ 1-Address

- sets the DMX start address

⇒ 2-FMW Name & Version

- displays the model name and the software version of the fixture

⇒ 3-No DMX Present

- if the DMX control signal from an external source is not detected, various standalone output options can be selected:

1 – OFF	Fixture has no output
2 – Hold Last	Fixture holds the last valid DMX state
3 – M1	Fixture snaps to the saved look in M1
4 – M2	Fixture snaps to the saved look in M2

⇒ 4-Technical

1 – DMX Data	DMX values of the LED channels are displayed								
2 – Temperature	Internal temperature is displayed								
3 – PWM Frequency	<p>The fixture can be set to various PWM frequencies to avoid flickering on camera:</p> <table border="1"> <tr> <td>750 Hz</td> <td>1.5 kHz</td> <td>3 kHz</td> <td>6 kHz</td> <td>12 kHz</td> <td>24 kHz</td> <td>48 kHz</td> <td>96 kHz</td> </tr> </table> <p>Note: Dimming will be more smooth at lower PWM frequencies.</p>	750 Hz	1.5 kHz	3 kHz	6 kHz	12 kHz	24 kHz	48 kHz	96 kHz
750 Hz	1.5 kHz	3 kHz	6 kHz	12 kHz	24 kHz	48 kHz	96 kHz		
4 – DMX Input	<p>Enables the input connection:</p> <table border="1"> <tr> <td>INPUT CABLE</td> <td>DMX from console via cable</td> </tr> <tr> <td>INPUT RF</td> <td>Wireless DMX from an external console</td> </tr> </table>	INPUT CABLE	DMX from console via cable	INPUT RF	Wireless DMX from an external console				
INPUT CABLE	DMX from console via cable								
INPUT RF	Wireless DMX from an external console								
5 – Engine LOAD	<p>Set this mode to enable the upload of LED engine software updates</p> <ul style="list-style-type: none"> <li>• Connect the fixture to the Uploader II</li> <li>• Enable Engine LOAD from the Technical menu</li> <li>• Initiate the upload from the Uploader II</li> </ul> <p>(Refer to the Uploader II Quick Start Guide for details <a href="http://www.chroma-q.com/support/downloads.asp">http://www.chroma-q.com/support/downloads.asp</a>)</p>								

⇒ 5-Reset Setting

- Resets all the control settings to the factory default

DMX Address	1
No DMX Present	Hold Last
Look Store	Look 1
PWM Frequency	96 kHz
DMX Input	INPUT CABLE

## 2.5 Thermal Performance

The internal cooling system of the fixture is by convection. It also features automatic protection that reduces the output when the internal temperature reaches the maximum limit due to extreme ambient conditions. See operating temperature range in the specification below.

### 3. Troubleshooting

Troubleshooting is a process of elimination. First, rule out the other field factors (i.e. bad connections, faulty cables and power supplies). For technical support and/or parts, please contact your selling dealer or the offices listed in this manual.

Symptom	Possible Cause	Solution
Fixture does not respond to DMX control.	<ul style="list-style-type: none"><li>• Set to wrong or different DMX address.</li><li>• Bad cable connecting DMX control and fixture.</li><li>• Bad in/through connection between adjacent fixtures.</li><li>• DMX input set incorrectly.</li></ul>	<ul style="list-style-type: none"><li>• Check DMX address and Mode settings.</li><li>• Check/replace DMX run from the console.</li></ul>
Low LED output.	<ul style="list-style-type: none"><li>• Internal temperature is over the limit.</li></ul>	<ul style="list-style-type: none"><li>• Check unit temperature via RDM or on the LCD display.</li><li>• Check area ventilation.</li></ul>
Flickering on camera.	<ul style="list-style-type: none"><li>• Frequency set incorrectly.</li></ul>	<ul style="list-style-type: none"><li>• Change PWM frequency.</li></ul>
Unit does not respond to RDM commands.	<ul style="list-style-type: none"><li>• Being controlled via non-RDM compliant splitter.</li></ul>	<ul style="list-style-type: none"><li>• Connect directly to RDM controller/gateway or use RDM enabled splitter.</li></ul>

## 4. Specification

### 4.1 Technical Specification

Product Code	CHSPFV Chroma-Q Space Force Variable w Bridle CHSPFVLR Chroma-Q Space Force Variable Bridle LumenRadio Installed
Net Dimensions (Without Fixings - Width x Height x Depth)	663mm x 203mm x 663mm / 26" x 8" x 26"
Net Weight (Without Fixings)	8 kg / 17.6 lb
Shipping Dimensions - Width x Height x Depth	737mm x 737mm x 254mm / 29" x 29" x 10"
Shipping Weight	11 kg / 24 lb
Power & Connections	
Power Supply	Built-in
Power Input Rating	100-240V AC 50-60Hz 400VA
Power Factor	0.9
Power Consumption	333W @ 120VAC, 331W @ 230VAC
Inrush Current	56A @ 120VAC, 82A @ 230VAC
Idle Power Consumption	18W @ 120/230VAC
Residual Current (max)	0.4 mA
Typical Power & Current	Measurements done with all LEDs at max. intensity. Measurements made at nominal voltage. Allow for deviation of +/- 10%.
Power Connectors In/Out	powerCON TRUE1
Data Connectors In/Out	XLR 5-pin
Control Protocol	ANSI E1.20 RDM over ANSI E1.11 USITT DMX 512-A,
Cooling System	Convection
Operating Temperature	0°C to 40°C
Construction	Powder-coated aluminum
Color	Black
IP Rating	*IP20
Approvals	CISPR 22:2008/EN55022:2010 (Class A), & CISPR 24:2010/EN55024:2010, FCC Part 15 Subpart B:2015, ICES-003:2012; UL 1573:2003/R:2014-01, CSA C22.2 No. 160-M1983, IEC 60598
Hot Lumen Output (combined)	up to 26,700
Optics	High efficiency diffuser
Beam Angle	60°
Beam Distribution	Symmetrical Direct Illumination
CCT	2,800 – 6,300K (+/-200K)
Sound Level	24.6 dB
Lamp Life	L70 at 50,000 hours

\*\*For exact measurements please refer to the line drawings below



## 4.2 Drawings

### DIMENSIONS

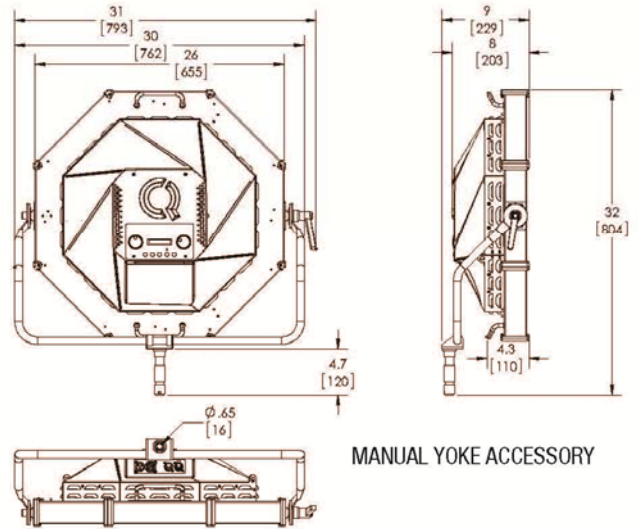
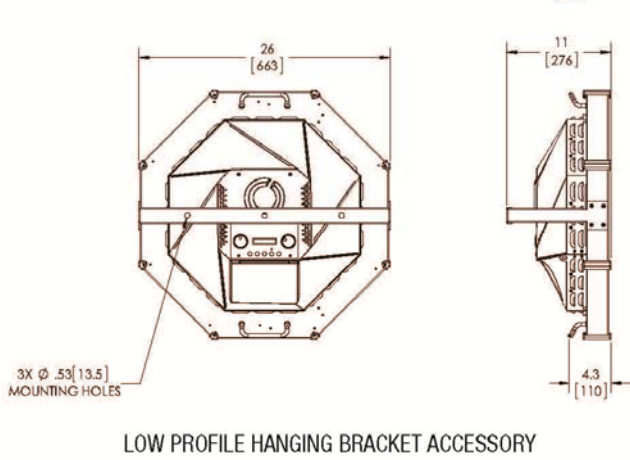
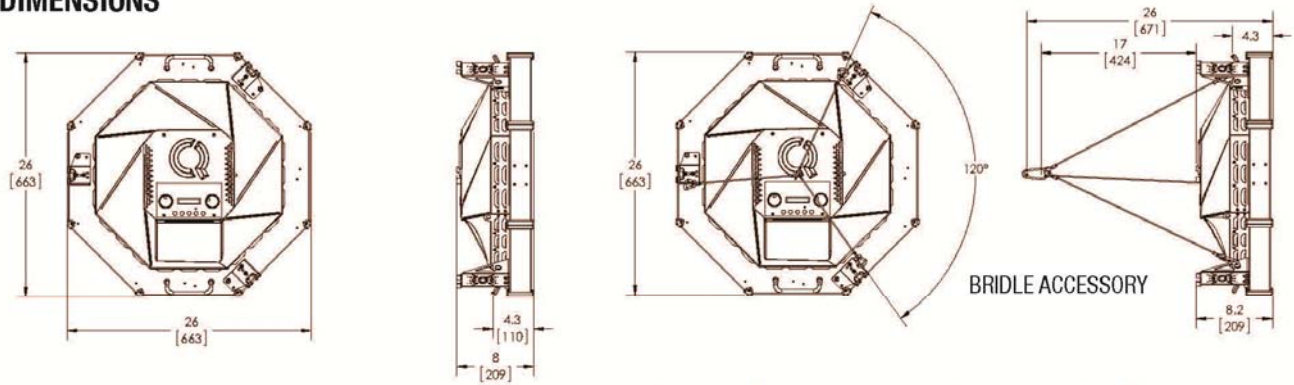

## 5. Accessories

CHSPFSY Chroma-Q Space Force Manual Yoke

CHSPFHB Chroma-Q Space Force Low Profile Hanging Bracket

CHSPFMS Chroma-Q Space Force Black Mini skirt

CHSPFSEC Chroma-Q Space Force Soft Egg Crate

CHSPFCK Chroma-Q Space Force Cyc Skirt/Silk

CHSPFSTK Chroma-Q Space Force Soft Target Kit - for use with a skirt Full, 1/2, 1/4, 1/8

CHSPFSL Chroma-Q Space Force Soft Lantern

CHSPFB Chroma-Q Space Force Bridle - included with fixture

CHSPFLR Chroma-Q Space Force LumenRadio Kit – User Installed

## 6. Maintenance

With care, the fixture requires little maintenance. However, as the unit is likely to be used in a stage environment we recommend periodical internal inspection and cleaning of any resulting dust and cracked oil residue.

Do not spray liquids on the front or rear panel. If the front panel requires cleaning, wipe with a soft cloth. Use a vacuum cleaner to remove dust.